

# NLSX3013

## 8-Bit 100 Mb/s Configurable Dual-Supply Level Translator

The NLSX3013 is a 8-bit configurable dual-supply bidirectional level translator without a direction control pin. The I/O  $V_{CC}$ - and I/O  $V_L$ -ports are designed to track two different power supply rails,  $V_{CC}$  and  $V_L$  respectively. The  $V_{CC}$  supply rail is configurable from 1.3 V to 4.5 V while the  $V_L$  supply rail is configurable from 0.9 V to ( $V_{CC} - 0.4$ ) V. This allows lower voltage logic signals on the  $V_L$  side to be translated into higher voltage logic signals on the  $V_{CC}$  side, and vice-versa. Both I/O ports are auto-sensing; thus, no direction pin is required.

The Output Enable (EN) input, when Low, disables both I/O ports by putting them in 3-state. This significantly reduces the supply currents from both  $V_{CC}$  and  $V_L$ . The EN signal is designed to track  $V_L$ .

### Features

- Wide High-Side  $V_{CC}$  Operating Range: 1.65 V to 4.5 V  
Wide Low-Side  $V_L$  Operating Range: 0.9 V to ( $V_{CC} - 0.4$ ) V
- High-Speed with 100 Mb/s Guaranteed Data Rate for  $V_L > 1.8$  V
- Low Bit-to-Bit Skew
- Overvoltage Tolerant Enable and I/O Pins
- Non-preferential Powerup Sequencing
- Small packaging: 2.03 mm x 2.54 mm 20 Pin Flip-Chip
- This is a Pb-Free Device

### Typical Applications

- Mobile Phones, PDAs, Other Portable Devices
- PC and Laptops



ON Semiconductor®

<http://onsemi.com>

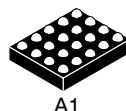

20 PIN FLIP-CHIP  
CASE 766AK

### MARKING DIAGRAM

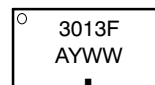

- A1
- A = Assembly Location
  - Y = Year
  - W = Work Week
  - = Pb-Free Package

### LOGIC DIAGRAM

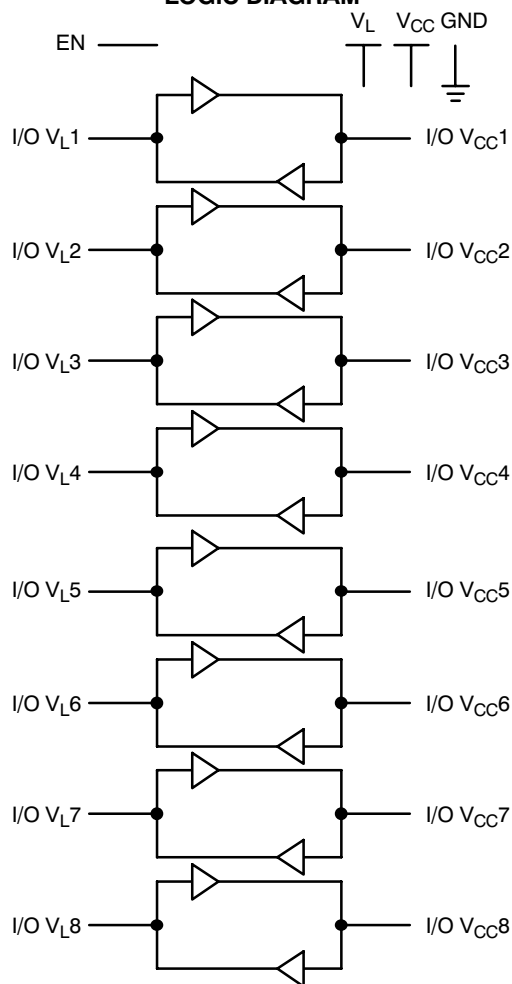

### ORDERING INFORMATION

See detailed ordering and shipping information in the package dimensions section on page 10 of this data sheet.

# NLSX3013

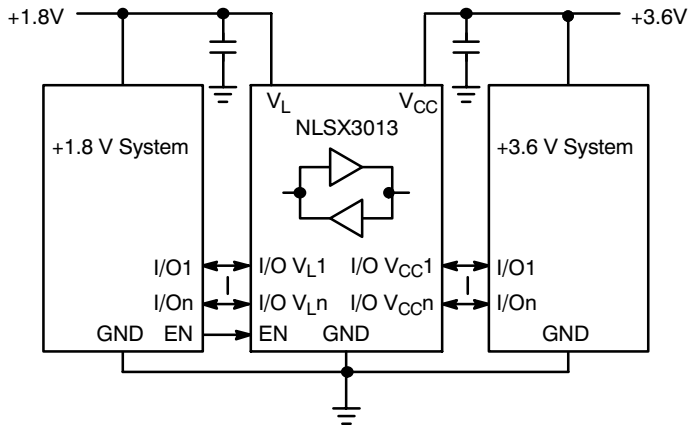

Figure 1. Typical Application Circuit

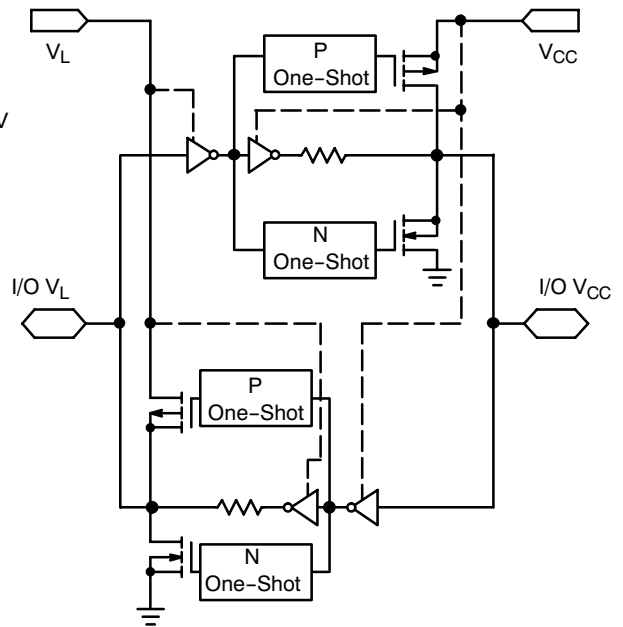

Figure 2. Simplified Functional Diagram (1 I/O Line)  
(EN = 1)

## PIN ASSIGNMENT

Pins	Description
V <sub>CC</sub>	V <sub>CC</sub> Input Voltage
V <sub>L</sub>	V <sub>L</sub> Input Voltage
GND	Ground
EN	Output Enable
I/O V <sub>CCn</sub>	I/O Port, Referenced to V <sub>CC</sub>
I/O V <sub>Ln</sub>	I/O Port, Referenced to V <sub>L</sub>

## FUNCTION TABLE

EN	Operating Mode
L	Hi-Z
H	I/O Buses Connected

# NLSX3013

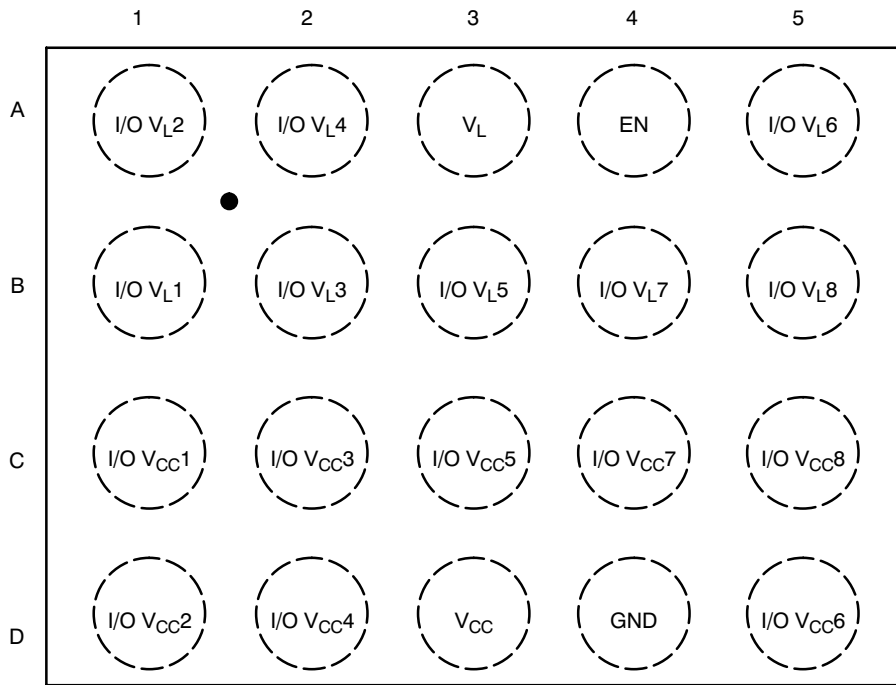

**Figure 3. 20 Flip-Chip (2.54 mm x 2.03 mm)**  
(Top View)

## PIN ASSIGNMENT

Pin	Name	Description
A1	I/O VL2	I/O Port 2, Referenced to VL
A2	I/O VL4	I/O Port 4, Referenced to VL
A3	VL	VL Input Voltage
A4	EN	Output Enable
A5	I/O VL6	I/O Port 6, Referenced to VL
B1	I/O VL1	I/O Port 1, Referenced to VL
B2	I/O VL3	I/O Port 3, Referenced to VL
B3	I/O VL5	I/O Port 5, Referenced to VL
B4	I/O VL7	I/O Port 7, Referenced to VL
B5	I/O VL8	I/O Port 8, Referenced to VL
C1	I/O VCC1	I/O Port 1, Referenced to VCC
C2	I/O VCC3	I/O Port 3, Referenced to VCC
C3	I/O VCC5	I/O Port 5, Referenced to VCC
C4	I/O VCC7	I/O Port 7, Referenced to VCC
C5	I/O VCC8	I/O Port 8, Referenced to VCC
D1	I/O VCC2	I/O Port 2, Referenced to VCC
D2	I/O VCC4	I/O Port 4, Referenced to VCC
D3	VCC	VCC Input Voltage
D4	GND	Ground
D5	I/O VCC6	I/O Port 6, Referenced to VCC

# NLSX3013

## MAXIMUM RATINGS

Symbol	Parameter	Value	Condition	Unit
$V_{CC}$	$V_{CC}$ Supply Voltage	-0.5 to +5.5		V
$V_L$	$V_L$ Supply Voltage	-0.5 to +5.5		V
I/O $V_{CC}$	$V_{CC}$ -Referenced DC Input/Output Voltage	-0.5 to ( $V_{CC} + 0.3$ )		V
I/O $V_L$	$V_L$ -Referenced DC Input/Output Voltage	-0.5 to ( $V_L + 0.3$ )		V
$V_{EN}$	Enable Control Pin DC Input Voltage	-0.5 to +5.5		V
$I_{IK}$	Input Diode Clamp Current	-50	$V_I < GND$	mA
$I_{OK}$	Output Diode Clamp Current	-50	$V_O < GND$	mA
$I_{CC}$	DC Supply Current Through $V_{CC}$	$\pm 100$		mA
$I_L$	DC Supply Current Through $V_L$	$\pm 100$		mA
$I_{GND}$	DC Ground Current Through Ground Pin	$\pm 100$		mA
$T_{STG}$	Storage Temperature	-65 to +150		$^{\circ}C$

Stresses exceeding Maximum Ratings may damage the device. Maximum Ratings are stress ratings only. Functional operation above the Recommended Operating Conditions is not implied. Extended exposure to stresses above the Recommended Operating Conditions may affect device reliability.

## RECOMMENDED OPERATING CONDITIONS

Symbol	Parameter	Min	Max	Unit
$V_{CC}$	$V_{CC}$ Supply Voltage	1.3	4.5	V
$V_L$	$V_L$ Supply Voltage	0.9	$V_{CC} - 0.4$	V
$V_{EN}$	Enable Control Pin Voltage	GND	4.5	V
$V_{IO}$	Bus Input/Output Voltage	I/O $V_{CC}$ I/O $V_L$	4.5 4.5	V
$T_A$	Operating Temperature Range	-40	+85	$^{\circ}C$
$\Delta I/\Delta V$	Input Transition Rise or Rate $V_I, V_{IO}$ from 30% to 70% of $V_{CC}$ ; $V_{CC} = 3.3 V \pm 0.3 V$	0	10	ns

DC ELECTRICAL CHARACTERISTICS

Symbol	Parameter	Test Conditions (Note 1)	V <sub>CC</sub> (V) (Note 2)	V <sub>L</sub> (V) (Note 3)	-40°C to +85°C			Unit
					Min	Typ (Note 4)	Max	
V <sub>IHC</sub>	I/O V <sub>CC</sub> Input HIGH Voltage		1.3 to 4.5	0.9 to (V <sub>CC</sub> - 0.4)	0.8 * V <sub>CC</sub>	-	-	V
V <sub>ILC</sub>	I/O V <sub>CC</sub> Input LOW Voltage		1.3 to 4.5	0.9 to (V <sub>CC</sub> - 0.4)	-	-	0.2 * V <sub>CC</sub>	V
V <sub>IHL</sub>	I/O V <sub>L</sub> Input HIGH Voltage		1.3 to 4.5	0.9 to (V <sub>CC</sub> - 0.4)	0.8 * V <sub>L</sub>	-	-	V
V <sub>ILL</sub>	I/O V <sub>L</sub> Input LOW Voltage		1.3 to 4.5	0.9 to (V <sub>CC</sub> - 0.4)	-	-	0.2 * V <sub>L</sub>	V
V <sub>IH</sub>	Control Pin Input HIGH Voltage	T <sub>A</sub> = +25°C	1.3 to 4.5	0.9 to (V <sub>CC</sub> - 0.4)	0.8 * V <sub>L</sub>	-	-	V
V <sub>IL</sub>	Control Pin Input LOW Voltage	T <sub>A</sub> = +25°C	1.3 to 4.5	0.9 to (V <sub>CC</sub> - 0.4)	-	-	0.2 * V <sub>L</sub>	V
V <sub>OHC</sub>	I/O V <sub>CC</sub> Output HIGH Voltage	I/O V <sub>CC</sub> Source Current = 20 μA	1.3 to 4.5	0.9 to (V <sub>CC</sub> - 0.4)	0.8 * V <sub>CC</sub>	-	-	V
V <sub>OLC</sub>	I/O V <sub>CC</sub> Output LOW Voltage	I/O V <sub>CC</sub> Sink Current = 20 μA	1.3 to 4.5	0.9 to (V <sub>CC</sub> - 0.4)	-	-	0.2 * V <sub>CC</sub>	V
V <sub>OHL</sub>	I/O V <sub>L</sub> Output HIGH Voltage	I/O V <sub>L</sub> Source Current = 20 μA	1.3 to 4.5	0.9 to (V <sub>CC</sub> - 0.4)	0.8 * V <sub>L</sub>	-	-	V
V <sub>OLL</sub>	I/O V <sub>L</sub> Output LOW Voltage	I/O V <sub>L</sub> Sink Current = 20 μA	1.3 to 4.5	0.9 to (V <sub>CC</sub> - 0.4)	-	-	0.2 * V <sub>L</sub>	V

1. Normal test conditions are V<sub>EN</sub> = 0 V, C<sub>I0VCC</sub> = 15 pF and C<sub>I0VL</sub> = 15 pF, unless otherwise specified.
2. V<sub>CC</sub> is the supply voltage associated with the high voltage port, and V<sub>CC</sub> ranges from +1.3 V to 4.5 V under normal operating conditions.
3. V<sub>L</sub> is the supply voltage associated with the low voltage port. V<sub>L</sub> must be less than or equal to (V<sub>CC</sub> - 0.4) V during normal operation. However, during startup and shutdown conditions, V<sub>L</sub> can be greater than (V<sub>CC</sub> - 0.4) V.
4. Typical values are for V<sub>CC</sub> = +2.8 V, V<sub>L</sub> = +1.8 V and T<sub>A</sub> = +25°C. All units are production tested at T<sub>A</sub> = +25°C. Limits over the operating temperature range are guaranteed by design.

# NLSX3013

## POWER CONSUMPTION

Symbol	Parameter	Test Conditions (Note 5)	V <sub>CC</sub> (V) (Note 6)	V <sub>L</sub> (V) (Note 7)	-40°C to +85°C			Unit
					Min	Typ	Max	
I <sub>Q-VCC</sub>	Supply Current from V <sub>CC</sub>	EN = V <sub>L</sub> ; I/O V <sub>CCn</sub> = 0 V, I/O V <sub>Ln</sub> = 0 V, I/O V <sub>CCn</sub> = V <sub>CC</sub> or I/O V <sub>Ln</sub> = V <sub>L</sub> and I <sub>o</sub> = 0	1.3 to 4.5	0.9 to (V <sub>CC</sub> - 0.4)	-	-	1.0	μA
I <sub>Q-VL</sub>	Supply Current from V <sub>L</sub>	EN = V <sub>L</sub> ; I/O V <sub>CCn</sub> = 0 V, I/O V <sub>Ln</sub> = 0 V, I/O V <sub>CCn</sub> = V <sub>CC</sub> or I/O V <sub>Ln</sub> = V <sub>L</sub> and I <sub>o</sub> = 0	1.3 to 4.5	0.9 to (V <sub>CC</sub> - 0.4)	-	-	1.0	μA
		EN = V <sub>L</sub> ; I/O V <sub>CCn</sub> = 0 V, I/O V <sub>Ln</sub> = 0 V, I/O V <sub>CCn</sub> = V <sub>CC</sub> or I/O V <sub>Ln</sub> = (V <sub>CC</sub> - 0.2 V) and I <sub>o</sub> = 0		< (V <sub>CC</sub> - 0.2)				
I <sub>TS-VCC</sub>	V <sub>CC</sub> Tristate Output Mode Supply Current	EN = 0 V	1.3 to 4.5	0.9 to (V <sub>CC</sub> - 0.4)	-	-	1.0	μA
I <sub>TS-VL</sub>	V <sub>L</sub> Tristate Output Mode Supply Current	EN = 0 V	1.3 to 4.5	0.9 to (V <sub>CC</sub> - 0.4)	-	-	0.2	μA
		EN = 0 V		V <sub>CC</sub> - 0.2				
I <sub>OZ</sub>	I/O Tristate Output Mode Leakage Current	EN = 0 V	2.8	1.8	-	-	0.15	μA
		EN = 0 V		V <sub>CC</sub> - 0.2				
I <sub>EN</sub>	Output Enable Pin Input Current	-	1.3 to 4.5	0.9 to (V <sub>CC</sub> - 0.4)	-	-	1.0	μA

5. Normal test conditions are V<sub>EN</sub> = 0 V, C<sub>IOVCC</sub> = 15 pF and C<sub>IOVL</sub> = 15 pF, unless otherwise specified.

6. V<sub>CC</sub> is the supply voltage associated with the high voltage port, and V<sub>CC</sub> ranges from +1.3 V to 4.5 V under normal operating conditions.

7. V<sub>L</sub> is the supply voltage associated with the low voltage port. V<sub>L</sub> must be less than or equal to (V<sub>CC</sub> - 0.4) V during normal operation. However, during startup and shutdown conditions, V<sub>L</sub> can be greater than (V<sub>CC</sub> - 0.4) V.

8. Typical values are for V<sub>CC</sub> = +2.8 V, V<sub>L</sub> = +1.8 V and T<sub>A</sub> = +25°C. All units are production tested at T<sub>A</sub> = +25°C. Limits over the operating temperature range are guaranteed by design.

# NLSX3013

## TIMING CHARACTERISTICS

Symbol	Parameter	Test Conditions (Note 9)	V <sub>CC</sub> (V) (Note 10)	V <sub>L</sub> (V) (Note 11)	-40°C to +85°C			Unit
					Min	Typ (Note 12)	Max	
t <sub>R-VCC</sub>	I/O V <sub>CC</sub> Rise Time (Output = I/O_V <sub>CC</sub> )	C <sub>I<sub>O</sub>V<sub>CC</sub></sub> = 15 pF	1.3 to 4.5	0.9 to (V <sub>CC</sub> - 0.4)		0.7	2.4	ns
t <sub>F-VCC</sub>	I/O V <sub>CC</sub> Falltime (Output = I/O_V <sub>CC</sub> )	C <sub>I<sub>O</sub>V<sub>CC</sub></sub> = 15 pF	1.3 to 4.5	0.9 to (V <sub>CC</sub> - 0.4)		0.5	1.0	ns
t <sub>R-VL</sub>	I/O V <sub>L</sub> Risetime (Output = I/O_V <sub>L</sub> )	C <sub>I<sub>O</sub>V<sub>L</sub></sub> = 15 pF	1.3 to 4.5	0.9 to (V <sub>CC</sub> - 0.4)		1.0	3.8	ns
t <sub>F-VL</sub>	I/O V <sub>L</sub> Falltime (Output = I/O_V <sub>L</sub> )	C <sub>I<sub>O</sub>V<sub>L</sub></sub> = 15 pF	1.3 to 4.5	0.9 to (V <sub>CC</sub> - 0.4)		0.6	1.2	ns
Z <sub>O-VCC</sub>	I/O V <sub>CC</sub> One-Shot Output Impedance		1.3 to 4.5	0.9 to (V <sub>CC</sub> - 0.4)		30		Ω
Z <sub>O-VL</sub>	I/O V <sub>L</sub> One-Shot Output Impedance		1.3 to 4.5	0.9 to (V <sub>CC</sub> - 0.4)		30		Ω
t <sub>PD_VL-VCC</sub>	Propagation Delay (Output = I/O_V <sub>CC</sub> , t <sub>PHL</sub> , t <sub>PLH</sub> )	C <sub>I<sub>O</sub>V<sub>CC</sub></sub> = 15 pF	1.3 to 4.5	0.9 to (V <sub>CC</sub> - 0.4)		4.5	9.3	ns
t <sub>PD_VCC-VL</sub>	Propagation Delay (Output = I/O_V <sub>L</sub> , t <sub>PHL</sub> , t <sub>PLH</sub> )	C <sub>I<sub>O</sub>V<sub>L</sub></sub> = 15 pF	1.3 to 4.5	0.9 to (V <sub>CC</sub> - 0.4)		3.0	6.5	ns
t <sub>SK_VL-VCC</sub>	Channel-to-Channel Skew (Output = I/O_V <sub>CC</sub> )	C <sub>I<sub>O</sub>V<sub>CC</sub></sub> = 15 pF	1.3 to 4.5	0.9 to (V <sub>CC</sub> - 0.4)		0.2	0.3	nS
t <sub>SK_VCC-VL</sub>	Channel-to-Channel Skew (Output = I/O_V <sub>L</sub> )	C <sub>I<sub>O</sub>V<sub>CC</sub></sub> = 15 pF	1.3 to 4.5	0.9 to (V <sub>CC</sub> - 0.4)		0.2	0.3	nS
	Maximum Data Rate	(Output = I/O_V <sub>CC</sub> , C <sub>I<sub>O</sub>V<sub>CC</sub></sub> = 15 pF) (Output = I/O_V <sub>L</sub> , C <sub>I<sub>O</sub>V<sub>L</sub></sub> = 15 pF)	1.3 to 4.5	0.9 to (V <sub>CC</sub> - 0.4)	110			Mb/s
			> 2.2	> 1.8	140			

9. Normal test conditions are V<sub>EN</sub> = 0 V, C<sub>I<sub>O</sub>V<sub>CC</sub></sub> = 15 pF and C<sub>I<sub>O</sub>V<sub>L</sub></sub> = 15 pF, unless otherwise specified.

10. V<sub>CC</sub> is the supply voltage associated with the high voltage port, and V<sub>CC</sub> ranges from +1.3 V to 4.5 V under normal operating conditions.

11. V<sub>L</sub> is the supply voltage associated with the low voltage port. V<sub>L</sub> must be less than or equal to (V<sub>CC</sub> - 0.4) V during normal operation. However, during startup and shutdown conditions, V<sub>L</sub> can be greater than (V<sub>CC</sub> - 0.4) V.

12. Typical values are for V<sub>CC</sub> = +2.8 V, V<sub>L</sub> = +1.8 V and T<sub>A</sub> = +25°C. All units are production tested at T<sub>A</sub> = +25°C. Limits over the operating temperature range are guaranteed by design.

ENABLE / DISABLE TIME MEASUREMENTS

Symbol	Parameter	Test Conditions (Note 13)	V <sub>CC</sub> (V) (Note 14)	V <sub>L</sub> (V) (Note 15)	-40°C to +85°C			Unit
					Min	Typ (Note 16)	Max	
t <sub>EN-VCC</sub>	Turn-On Enable Time (Output = I/O_V <sub>CC</sub> , t <sub>pZH</sub> )	C <sub>IOVCC</sub> = 15 pF	1.3 to 4.5	0.9 to (V <sub>CC</sub> - 0.4)		130	180	ns
	Turn-On Enable Time (Output = I/O_V <sub>CC</sub> , t <sub>pZL</sub> )	C <sub>IOVL</sub> = 15 pF	1.3 to 4.5	0.9 to (V <sub>CC</sub> - 0.4)		100	150	ns
t <sub>EN-VL</sub>	Turn-On Enable Time (Output = I/O_V <sub>L</sub> , t <sub>pZH</sub> )	C <sub>IOVCC</sub> = 15 pF	1.3 to 4.5	0.9 to (V <sub>CC</sub> - 0.4)		95	185	ns
	Turn-On Enable Time (Output = I/O_V <sub>L</sub> , t <sub>pZL</sub> )	C <sub>IOVL</sub> = 15 pF	1.3 to 4.5	0.9 to (V <sub>CC</sub> - 0.4)		70	110	ns
t <sub>DIS-VCC</sub>	Turn-Off Disable Time (Output = I/O_V <sub>CC</sub> , t <sub>pHZ</sub> )	C <sub>IOVCC</sub> = 15 pF	1.3 to 4.5	0.9 to (V <sub>CC</sub> - 0.4)		175	250	ns
	Propagation Delay (Output = I/O_V <sub>CC</sub> , t <sub>pLZ</sub> )	C <sub>IOVL</sub> = 15 pF	1.3 to 4.5	0.9 to (V <sub>CC</sub> - 0.4)		150	190	ns
t <sub>DIS-VL</sub>	Turn-Off Disable Time (Output = I/O_V <sub>L</sub> , t <sub>pHZ</sub> )	C <sub>IOVCC</sub> = 15 pF	1.3 to 4.5	0.9 to (V <sub>CC</sub> - 0.4)		180	250	ns
	Propagation Delay (Output = I/O_V <sub>L</sub> , t <sub>pLZ</sub> )	C <sub>IOVL</sub> = 15 pF	1.3 to 4.5	0.9 to (V <sub>CC</sub> - 0.4)		160	220	ns

- 13. Normal test conditions are V<sub>EN</sub> = 0 V, C<sub>IOVCC</sub> = 15 pF and C<sub>IOVL</sub> = 15 pF, unless otherwise specified.
- 14. V<sub>CC</sub> is the supply voltage associated with the high voltage port, and V<sub>CC</sub> ranges from +1.3 V to 4.5 V under normal operating conditions.
- 15. V<sub>L</sub> is the supply voltage associated with the low voltage port. V<sub>L</sub> must be less than or equal to (V<sub>CC</sub> - 0.4) V during normal operation. However, during startup and shutdown conditions, V<sub>L</sub> can be greater than (V<sub>CC</sub> - 0.4) V.
- 16. Typical values are for V<sub>CC</sub> = +2.8 V, V<sub>L</sub> = +1.8 V and T<sub>A</sub> = +25 °C. All units are production tested at T<sub>A</sub> = +25 °C. Limits over the operating temperature range are guaranteed by design.

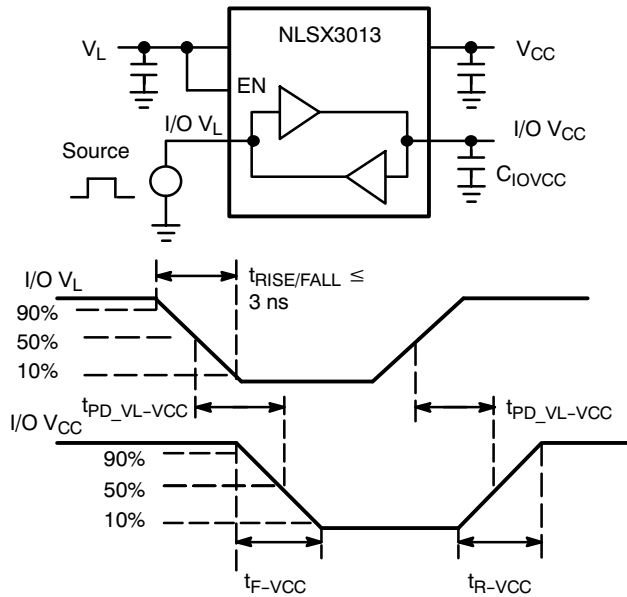

Figure 4. Driving I/O V<sub>L</sub> Test Circuit and Timing

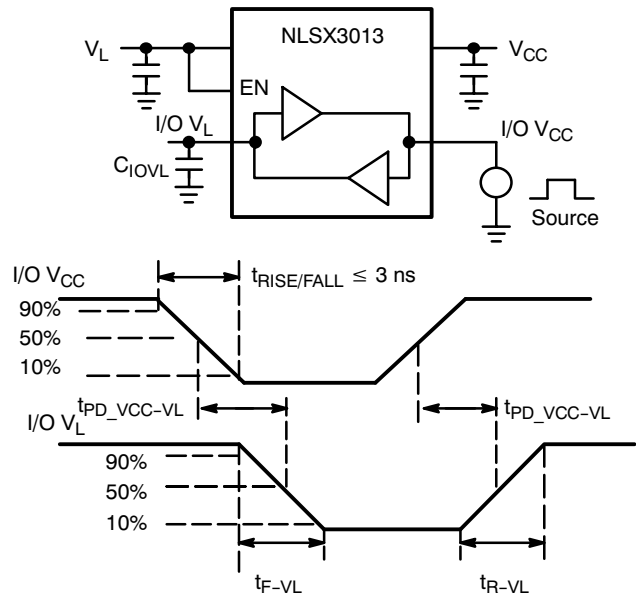
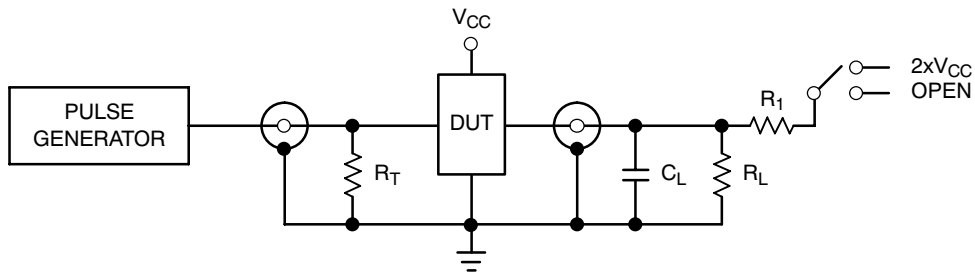

Figure 5. Driving I/O V<sub>CC</sub> Test Circuit and Timing



# NLSX3013



Test	Switch
$t_{PZH}$ , $t_{PHZ}$	Open
$t_{PZL}$ , $t_{PLZ}$	$2 \times V_{CC}$

$C_L = 15 \text{ pF}$  or equivalent (Includes jig and probe capacitance)  
 $R_L = R_1 = 50 \text{ k}\Omega$  or equivalent  
 $R_T = Z_{OUT}$  of pulse generator (typically  $50 \Omega$ )

**Figure 6. Test Circuit for Enable/Disable Time Measurement**

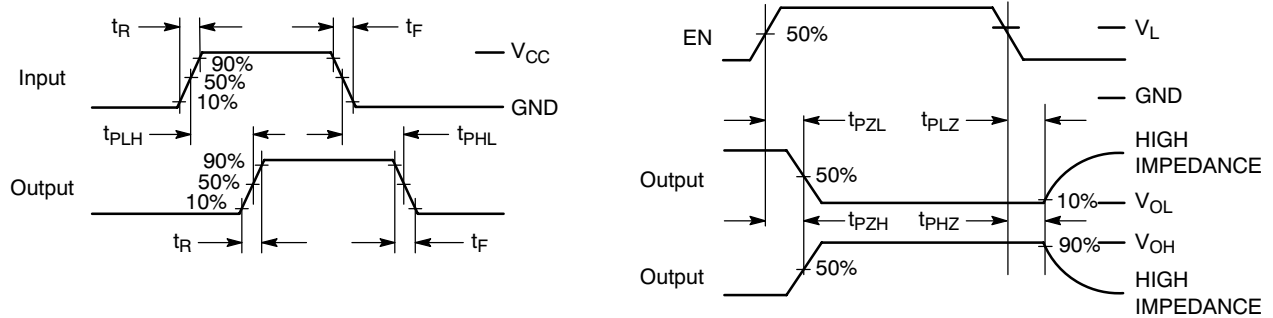

**Figure 7. Timing Definitions for Propagation Delays and Enable/Disable Measurement**

**IMPORTANT APPLICATIONS INFORMATION**

**Level Translator Architecture**

The NLSX3013 auto sense translator provides bi-directional voltage level shifting to transfer data in multiple supply voltage systems. This device has two supply voltages,  $V_L$  and  $V_{CC}$ , which set the logic levels on the input and output sides of the translator. When used to transfer data from the  $V_L$  to the  $V_{CC}$  ports, input signals referenced to the  $V_L$  supply are translated to output signals with a logic level matched to  $V_{CC}$ . In a similar manner, the  $V_{CC}$  to  $V_L$  translation shifts input signals with a logic level compatible to  $V_{CC}$  to an output signal matched to  $V_L$ .

The NLSX3013 consists of four bi-directional channels that independently determine the direction of the data flow without requiring a directional pin. The one-shot circuits are used to detect the rising or falling input signals. In addition, the one shots decrease the rise and fall time of the output signal for high-to-low and low-to-high transitions.

**Input Driver Requirements**

Auto sense translators such as the NLSX3013 have a wide bandwidth, but a relatively small DC output current rating. The high bandwidth of the bi-directional I/O circuit is used to quickly transform from an input to an output driver and vice versa. The I/O ports have a modest DC current output specification so that the output driver can be over driven when data is sent to in the opposite direction.

For proper operation, the input driver to the auto sense translator should be capable of driving 20 mA of peak output current with an output impedance less than 25  $\Omega$ . The bi-directional configuration of the translator results in both input stages being active for a very short time period. Although the peak current from the input signal circuit is relatively large, the average current is small and consistent with a standard CMOS input stage.

**Output Load Requirements**

The NLSX3013 is designed to drive CMOS inputs. Resistive pullup or pulldown loads of less than 50 k $\Omega$  should not be used with this device. The NLSX3373 or NLSX3378 open-drain auto sense translators are alternate

translator options for an application such as the I<sup>2</sup>C bus that requires pullup resistors.

**Enable Input (EN)**

The NLSX3013 has an Enable pin (EN) that provides tri-state operation at the I/O pins. Driving the Enable pin to a low logic level minimizes the power consumption of the device and drives the I/O  $V_{CC}$  and I/O  $V_L$  pins to a high impedance state. Normal translation operation occurs when the EN pin is equal to a logic high signal. The EN pin is referenced to the  $V_L$  supply and has Over-Voltage Tolerant (OVT) protection.

**Uni-Directional versus Bi-Directional Translation**

The NLSX3013 can function as a non-inverting uni-directional translator. One advantage of using the translator as a uni-directional device is that each I/O pin can be configured as either an input or output. The configurable input or output feature is especially useful in applications such as SPI that use multiple uni-directional I/O lines to send data to and from a device. The flexible I/O port of the auto sense translator simplifies the trace connections on the PCB.

**Power Supply Guidelines**

It is recommended that the  $V_L$  supply should be less than or equal to the value of the  $V_{CC}$  minus 0.4 V. The sequencing of the power supplies will not damage the device during the power up operation; however, the current consumption of the device will increase if  $V_L$  exceeds  $V_{CC}$  minus 0.4 V. In addition, the I/O  $V_{CC}$  and I/O  $V_L$  pins are in the high impedance state if either supply voltage is equal to 0 V.

For optimal performance, 0.01 to 0.1  $\mu$ F decoupling capacitors should be used on the  $V_L$  and  $V_{CC}$  power supply pins. Ceramic capacitors are a good design choice to filter and bypass any noise signals on the power supply voltage lines to the ground plane of the PCB. The noise immunity will be maximized by placing the capacitors as close as possible to the supply and ground pins, along with minimizing the PCB connection traces.

**ORDERING INFORMATION**

Device	Package	Shipping <sup>†</sup>
NLSX3013FCT1G	20 Pin Flip-Chip (Pb-Free)	3000 / Tape & Reel

<sup>†</sup>For information on tape and reel specifications, including part orientation and tape sizes, please refer to our Tape and Reel Packaging Specifications Brochure, BRD8011/D.

# NLSX3013

## PACKAGE DIMENSIONS

### 20 PIN FLIP-CHIP CSP CASE 766AK-01 ISSUE O

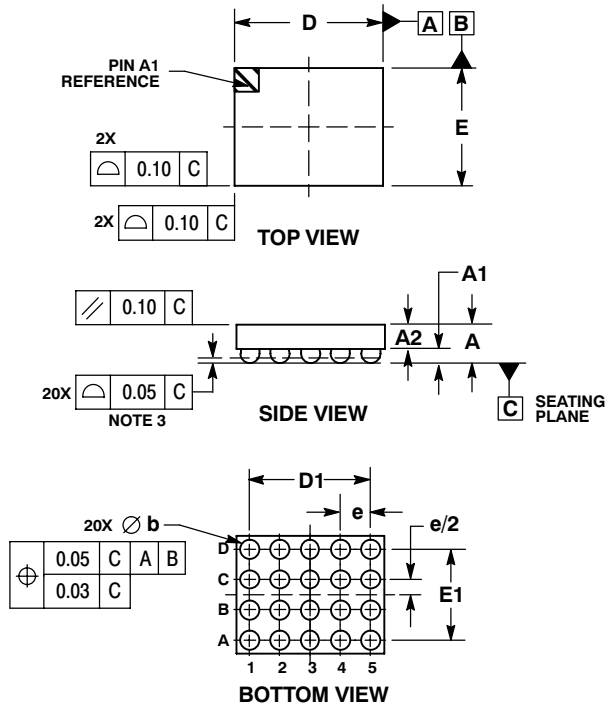

NOTES:

1. DIMENSIONING AND TOLERANCING PER ASME Y14.5M, 1994.
2. CONTROLLING DIMENSION: MILLIMETERS.
3. COPLANARITY APPLIES TO SPHERICAL CROWNS OF SOLDER BALLS.

MILLIMETERS		
DIM	MIN	MAX
A	---	0.66
A1	0.21	0.27
A2	0.33	0.39
b	0.29	0.34
D	2.54 BSC	
D1	2.00 BSC	
E	2.03 BSC	
E1	1.50 BSC	
e	0.50 BSC	

**ON Semiconductor** and are registered trademarks of Semiconductor Components Industries, LLC (SCILLC). SCILLC reserves the right to make changes without further notice to any products herein. SCILLC makes no warranty, representation or guarantee regarding the suitability of its products for any particular purpose, nor does SCILLC assume any liability arising out of the application or use of any product or circuit, and specifically disclaims any and all liability, including without limitation special, consequential or incidental damages. "Typical" parameters which may be provided in SCILLC data sheets and/or specifications can and do vary in different applications and actual performance may vary over time. All operating parameters, including "Typicals" must be validated for each customer application by customer's technical experts. SCILLC does not convey any license under its patent rights nor the rights of others. SCILLC products are not designed, intended, or authorized for use as components in systems intended for surgical implant into the body, or other applications intended to support or sustain life, or for any other application in which the failure of the SCILLC product could create a situation where personal injury or death may occur. Should Buyer purchase or use SCILLC products for any such unintended or unauthorized application, Buyer shall indemnify and hold SCILLC and its officers, employees, subsidiaries, affiliates, and distributors harmless against all claims, costs, damages, and expenses, and reasonable attorney fees arising out of, directly or indirectly, any claim of personal injury or death associated with such unintended or unauthorized use, even if such claim alleges that SCILLC was negligent regarding the design or manufacture of the part. SCILLC is an Equal Opportunity/Affirmative Action Employer. This literature is subject to all applicable copyright laws and is not for resale in any manner.

#### PUBLICATION ORDERING INFORMATION

**LITERATURE FULFILLMENT:**  
Literature Distribution Center for ON Semiconductor  
P.O. Box 5163, Denver, Colorado 80217 USA  
**Phone:** 303-675-2175 or 800-344-3860 Toll Free USA/Canada  
**Fax:** 303-675-2176 or 800-344-3867 Toll Free USA/Canada  
**Email:** orderlit@onsemi.com

**N. American Technical Support:** 800-282-9855 Toll Free  
USA/Canada  
**Europe, Middle East and Africa Technical Support:**  
Phone: 421 33 790 2910  
**Japan Customer Focus Center**  
Phone: 81-3-5773-3850

**ON Semiconductor Website:** [www.onsemi.com](http://www.onsemi.com)  
**Order Literature:** <http://www.onsemi.com/orderlit>

For additional information, please contact your local Sales Representative

NLSX3013/D