



July 1987

## MM82PC12 8-Bit Input/Output Port

### General Description

The MM82PC12 is a microCMOS 8-bit input/output port contained in a standard 24-pin dual-in-line package. The MM82PC12 can be used to implement latches, gated buffers, or multiplexers. Thus, all of the major peripheral and input/output functions of a microcomputer system can be implemented with this device.

The MM82PC12 includes an 8-bit latch with TRI-STATE® output buffers, and device selection and control logic. Also included is a service request flip-flop for the generation and control of interrupts to the microprocessor.

The MM82PC12 is pinout and function compatible with standard INS8212 and DP8212 devices.

For military applications, the MM82PC12 is available with class B screening in accordance with method 5004 of MIL-STD-883.

### Features

- Drive capability—150 pF load
- High noise immunity
- Low power dissipation
- Full interface to CMOS logic levels
- microCMOS technology
- TTL drive capability when  $V_{CC} = 5V$
- 8-bit data latch and buffer
- Service request flip-flop for generation and control of interrupts
- 1  $\mu A$  input load current
- Reduces system package count by replacing buffers, latches, and multiplexers in microcomputer systems

### System Configuration

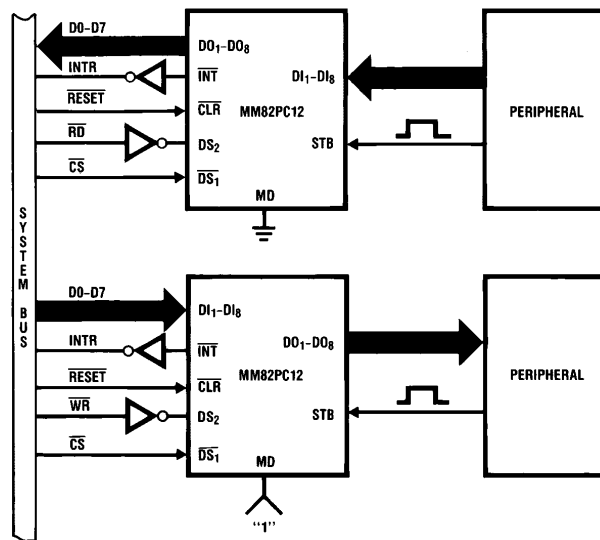

TL/C/5596-1

TRI-STATE® is a registered trademark of National Semiconductor Corp.

## Absolute Maximum Ratings

If Military/Aerospace specified devices are required, please contact the National Semiconductor Sales Office/Distributors for availability and specifications.

Storage Temperature Range	-65°C to +150°C
Voltage at Any Pin With Respect to Ground	-0.3V to $V_{CC} + 0.3V$
Lead Temperature (Soldering, 10 seconds)	300°C
Power Dissipation	500 mW
Maximum $V_{CC}$	7V

Note: Absolute maximum ratings are those values beyond which the safety of the device cannot be guaranteed. Continuous operation at these limits is not intended; operation should be limited to those conditions specified under DC Electrical Characteristics.

## Operating Range $V_{CC} = 5V \pm 10\%$

Ambient Temperature	
Military	-55°C to +125°C
Industrial	-40°C to +85°C
Commercial	0°C to +70°C

## DC Electrical Characteristics

$V_{CC} = 5V \pm 10\%$ , GND = 0V, unless otherwise specified

Symbol	Parameter	Test Conditions	Min	Typ	Max	Units
$V_{IH}$	Input High Voltage		$0.7 V_{CC}$		$V_{CC}$	V
$V_{IL}$	Input Low Voltage		0		$0.2 V_{CC}$	V
$V_{OH}$	Output High Voltage	$V_{CC} = 4.5V, V_{IH} = 4.5V, I_{OH} = -2 \text{ mA}$	2.4			V
$V_{OL}$	Output Low Voltage	$V_{CC} = 5.5V, V_{IL} = 0V, V_{IH} = 5.5V, I_{OL} = 2 \text{ mA}$			0.4	V
$I_{IH}$	Input High Current	$V_{CC} = 5.5V, V_{IN} = 5.5V$			10	$\mu A$
$I_{IL}$	Input Low Current	$V_{CC} = 5.5V, V_{IN} = 0V$			-10	$\mu A$
$I_{OH}$	Output High Current	$V_{CC} = 4.5V, V_{OUT} = 2.4V, V_{IH} = 4.5V$	-2.0			mA
$I_{OL}$	Output Low Current	$V_{CC} = 5.5V, V_{OUT} = 0.4V, V_{IL} = 0V$	2.0			mA
$I_{CC}$	Power Supply Current	$V_{CC} = 5.5V, V_{IH} = 5.5V, V_{IL} = 0V$			400	$\mu A$
$I_{OZL}$	TRI-STATE Low Leakage Current	$V_{CC} = 5.5V, V_{OUT} = 0V$			-10	$\mu A$
$I_{OZH}$	TRI-STATE High Leakage Current	$V_{CC} = 4.5V, V_{OUT} = 4.5V$			10	$\mu A$

## AC Electrical Characteristics

$T_A = -55^\circ C$  to  $+125^\circ C$ ,  $V_{CC} = 5V \pm 10\%$ , GND = 0V, unless otherwise specified

Symbol	Parameter	Test Conditions	Min	Typ	Max	Units
$t_{PW}$	Pulse Width (STB, DS1 • DS2, CLR)			25	40	ns
$t_{PD}$	Data In to Data Out			45	60	ns
$t_{WE}$	Write Enable to Data Out			55	75	ns
$t_{SET}$	Data Setup Time		15			ns
$t_H$	Data Hold Time		20			ns
$t_R$	Reset to Data Out			50	65	ns
$t_S$	Select to Interrupt			50	65	ns
$t_C$	Clear to Data Out			45	60	ns
$t_{ED}$	Output Enable/Disable Time			50	65	ns

# Timing Waveforms

## Read Timing

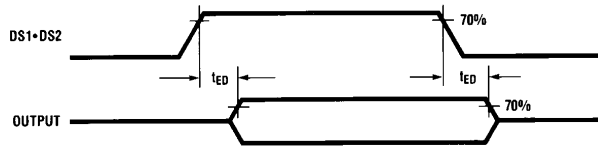

TL/C/5596-2

## Write Timing

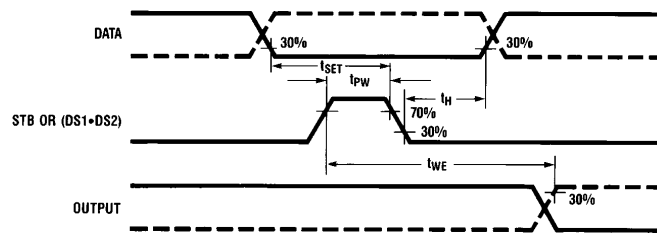

TL/C/5596-3

## Data Setup, Hold Delay Timing

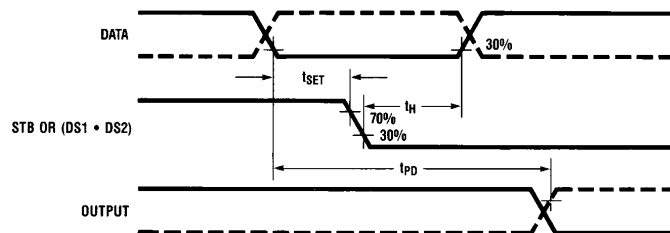

TL/C/5596-4

## Interrupt Timing

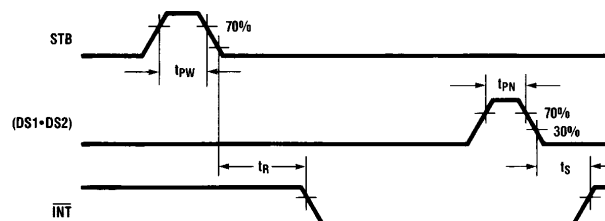

TL/C/5596-5

## Clear Timing

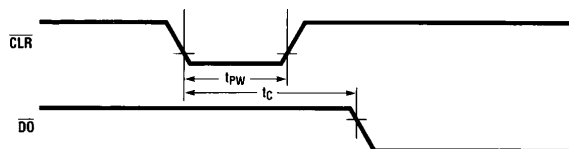

TL/C/5596-6

## Propagation Delays

Figure 1 illustrates the calculations of a more useful propagation delay. The figure uses a 5V supply with a tolerance of  $\pm 10\%$ , ambient temperature of  $+25^\circ\text{C}$ , and a load capacitance of 100 pF. The AC Characteristics table depicts  $t_{PD}$ , at 5V,  $25^\circ\text{C}$ , equalling 25 ns. Use the graph in Figure 1 to get the degradation multiple for 150 pF. The number shown is 1.09. The adjusted propagation delay is, therefore  $25 \times 1.09$  or 27 ns.

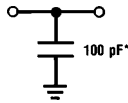

TL/C/5596-7

\*Including jig and probe capacitance.

### Output Test Circuit for Propagation Delays

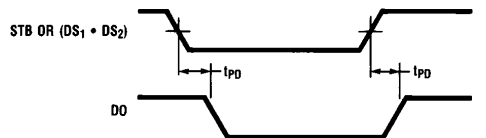

TL/C/5596-8

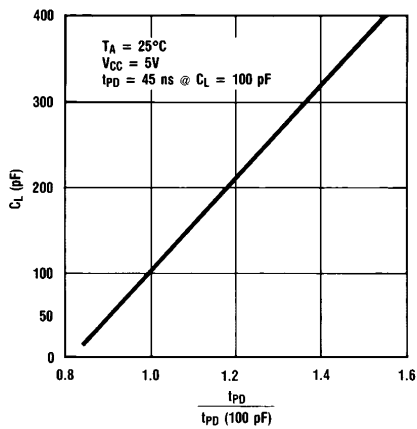

TL/C/5596-9

FIGURE 1. Normalized Typical Propagation Delay vs. Load Capacitance

## Pin Descriptions

The following describes the function of all the MM82PC12 input/output pins. Some of these descriptions reference internal circuits.

### INPUT SIGNALS

**Device Select ( $\overline{DS}_1$ ,  $DS_2$ ):** When  $\overline{DS}_1$  is low and  $DS_2$  is high, the device is selected. The output buffers are enabled and the service request flip-flop is asynchronously reset (cleared) when the device is selected.

**Mode (MD):** When MD is high (output mode), the output buffers are enabled and the source of the data latch clock input is the device selection logic ( $DS_1 \bullet DS_2$ ). When MD is low (input mode), the state of the output buffers is determined by the device selection logic ( $DS_1 \bullet DS_2$ ) and the source of the data latch clock input is the strobe (STB) input.

**Strobe (STB):** STB is used as the data latch clock input when the mode (MD) input is low (input mode). STB is also used to synchronously set the service request flip-flop, which is negative edge triggered.

**Data In ( $DI_1$ – $DI_8$ ):** Data In is the 8-bit data input to the data latch, which consists of eight D-type flip-flops incorporating a level sensitive clock. While the data latch clock input is high, the Q output of each flip-flop follows the data input. When the clock input returns low, the data latch stores the data input. Clear ( $\overline{CLR}$ ) is only effective when the clock is low (latch in the latched state).

**Clear ( $\overline{CLR}$ ):** When  $\overline{CLR}$  is low, the data latch is reset (cleared) if the clock is also low. The clock input high overrides the clear ( $\overline{CLR}$ ) input data latch reset.  $\overline{CLR}$  being low also resets the service request flip-flop. The service request flip-flop is in the non-interrupting state when reset.

### OUTPUT SIGNALS

**Interrupt ( $\overline{INT}$ ):** The interrupt pin goes low (interrupting state) when either the service request flip-flop is synchronously set by the strobe (STB) input or the device is selected.

**Data Out ( $DO_1$ – $DO_8$ ):** Data Out is the 8-bit data output of data buffers, which are TRI-STATE, non-inverting stages. These buffers have a common control line that either enables the buffers to transmit the data from the data latch outputs or disables the buffers by placing them in the high-impedance state.

## Reliability Information

Gate Count 108

Transistor Count 248

## Connection Diagrams

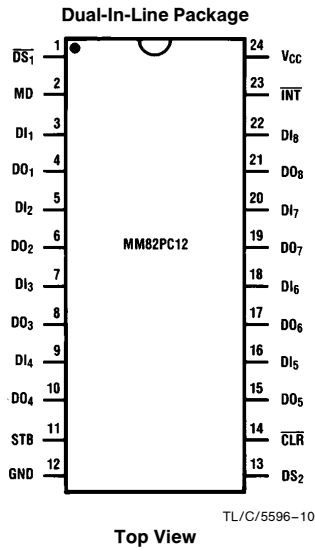

Top View

Order Number MM82PC12J or N  
See NS Package Number J24A or N24A

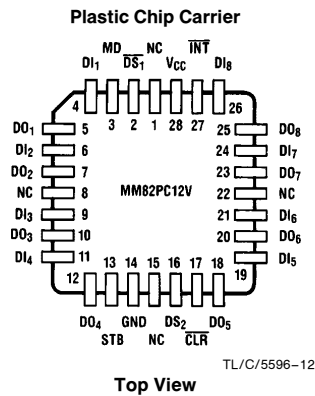

Top View

Order Number MM82PC12V  
See NS Package Number V28A

Logic Table A

STB	MD	DS <sub>1</sub> • DS <sub>2</sub>	Data Out Equals
0	0	0	TRI-STATE
1	0	0	TRI-STATE
0	1	0	Data Latch
1	1	0	Data Latch
0	0	1	Data Latch
1	0	1	Data In
0	1	1	Data In
1	1	1	Data In

Note:  $\overline{\text{CLR}}$  resets data latch to the output low state. The data latch clock is level sensitive, a low level clock latches the data.

## Logic Diagram

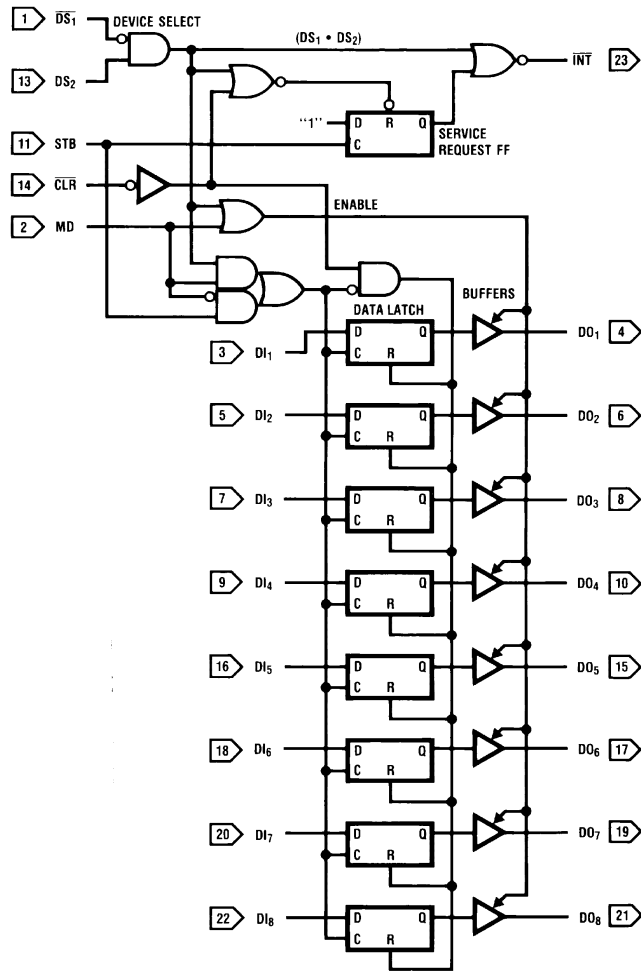

TL/C/5596-11

Logic Table B

CLR	DS <sub>1</sub> • DS <sub>2</sub>	STB	Q*	INT
0 RESET	0	0	0	1
1	0	0	0	1
1	0	~	1	0
1	1 RESET	0	0	0
1	0	0	0	1

\*Internal Service Request flip-flop.

# Applications in Microcomputer Systems

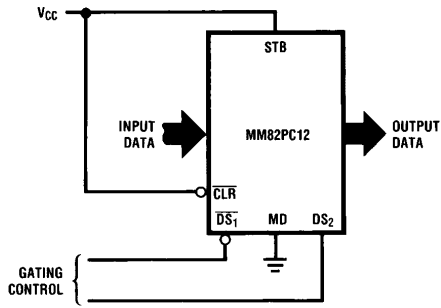

**Gated Buffer (TRI-STATE)**

TL/C/5596-13

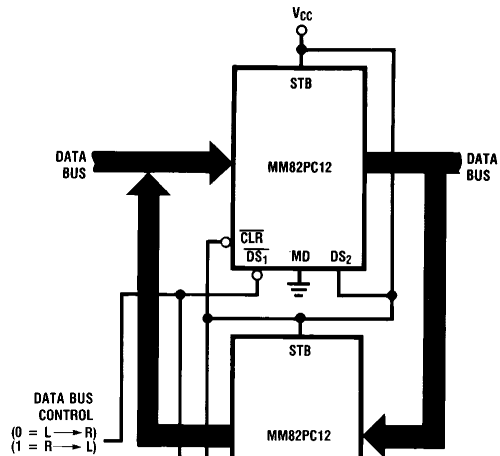

**Bidirectional Bus Driver**

TL/C/5596-14

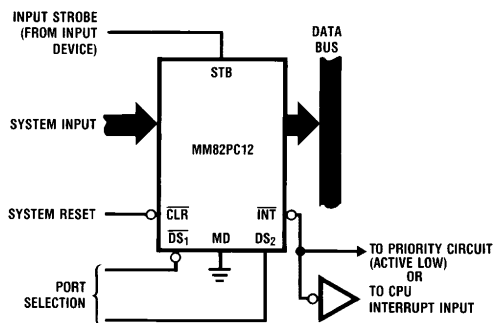

**Interrupting Input Port**

TL/C/5596-15

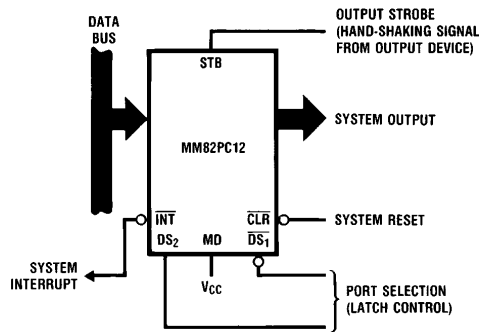

**Output Port (with Handshaking)**

TL/C/5596-17

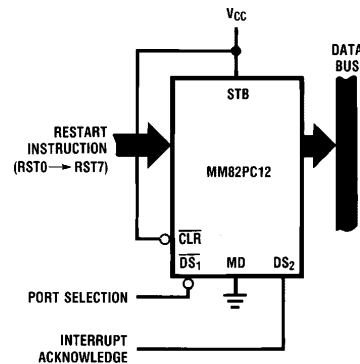

**Interrupt Instruction Port**

TL/C/5596-16

## Ordering Information

### MM82PC12XXX

- /A + = A + Reliability Screening
- /883 = MIL-STD-883B Screening (Note 1)
- I = Industrial Temperature (-40°C to +85°C)
- M = Military Temperature (-55°C to +125°C)
- No Designation = Commercial Temperature (0°C to +70°C)
- N = Plastic Package
- J = Cerdip Package
- V = Plastic Leaded Chip Carrier (PCC) (Availability to be announced)

TL/C/5596-18

**Note 1:** Do not specify a temperature option; all parts are screened to military temperature.

## Physical Dimensions inches (millimeters)

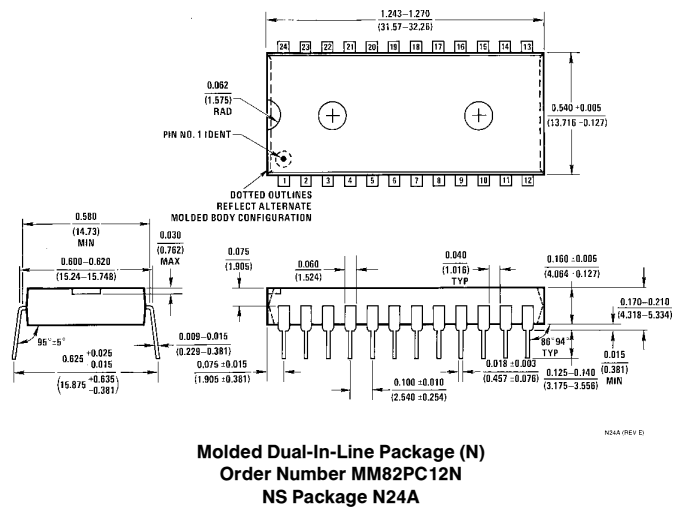
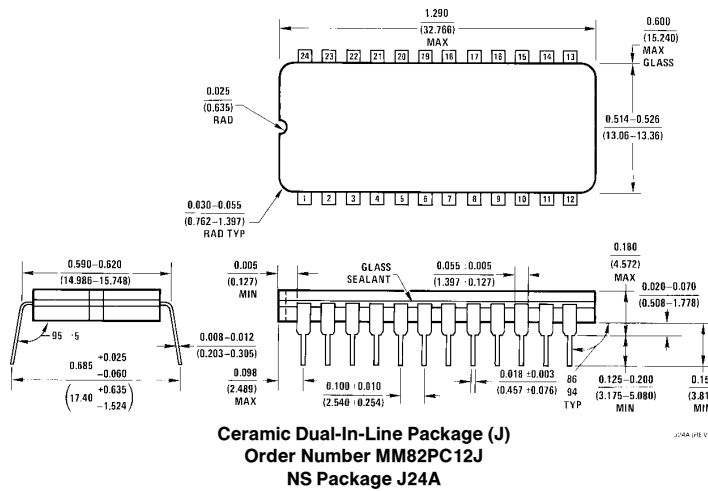

**Physical Dimensions** inches (millimeters) (Continued)

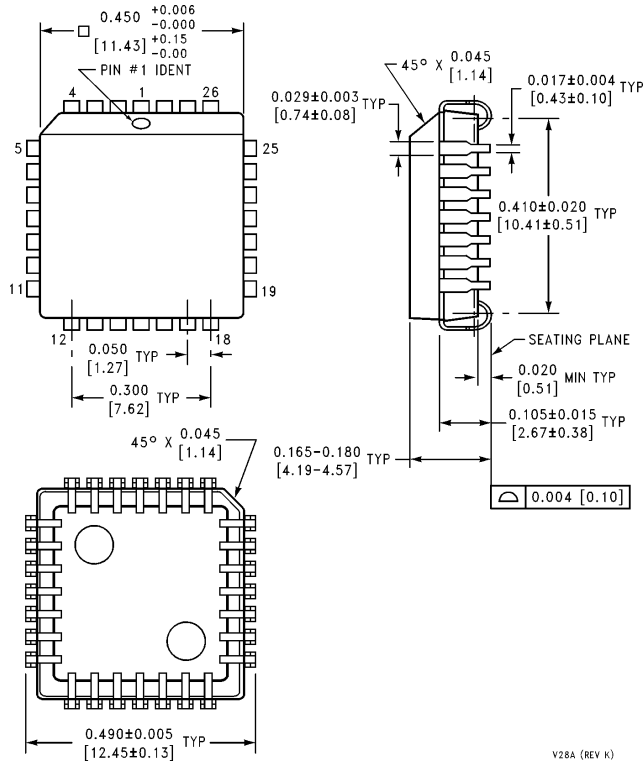

**Plastic Chip Carrier Package (V)**  
**Order Number MM82PC12V**  
**NS Package V28A**

V28A (REV K)

**LIFE SUPPORT POLICY**

NATIONAL'S PRODUCTS ARE NOT AUTHORIZED FOR USE AS CRITICAL COMPONENTS IN LIFE SUPPORT DEVICES OR SYSTEMS WITHOUT THE EXPRESS WRITTEN APPROVAL OF THE PRESIDENT OF NATIONAL SEMICONDUCTOR CORPORATION. As used herein:

1. Life support devices or systems are devices or systems which, (a) are intended for surgical implant into the body, or (b) support or sustain life, and whose failure to perform, when properly used in accordance with instructions for use provided in the labeling, can be reasonably expected to result in a significant injury to the user.
2. A critical component is any component of a life support device or system whose failure to perform can be reasonably expected to cause the failure of the life support device or system, or to affect its safety or effectiveness.



**National Semiconductor Corporation**  
 1111 West Bardin Road  
 Arlington, TX 76017  
 Tel: 1(800) 272-9959  
 Fax: 1(800) 737-7018

**National Semiconductor Europe**  
 Fax: (+49) 0-180-530 85 86  
 Email: cnjwge@tevm2.nsc.com  
 Deutsch Tel: (+49) 0-180-530 85 85  
 English Tel: (+49) 0-180-532 78 32  
 Français Tel: (+49) 0-180-532 93 58  
 Italiano Tel: (+49) 0-180-534 16 80

**National Semiconductor Hong Kong Ltd.**  
 19th Floor, Straight Block,  
 Ocean Centre, 5 Canton Rd.  
 Tsimshatsui, Kowloon  
 Hong Kong  
 Tel: (852) 2737-1600  
 Fax: (852) 2736-9960

**National Semiconductor Japan Ltd.**  
 Tel: 81-043-299-2309  
 Fax: 81-043-299-2408

National does not assume any responsibility for use of any circuitry described, no circuit patent licenses are implied and National reserves the right at any time without notice to change said circuitry and specifications.