

3.3V, 2-Port, 20-Bit Bus Switch with Precharged Outputs for Live Insertion

Product Features

- Near zero propagation delay
- 5-ohm switch connection between two ports
- High Bandwidth (>200 MHz)
- Rail-to-Rail 3.3V Switching
- Outputs are precharged by bias voltage to minimize signal distortion during live insertion
- 5V I/O Tolerant
- Package options:
 - 48-pin 150 mil wide plastic BQSOP (B)
 - 48-pin 240 mil wide plastic TSSOP (A)

Product Description

Pericom Semiconductor’s PI3C series of logic circuits are produced using the Company’s advanced submicron CMOS technology, achieving industry leading performance.

The PI3C16215 is a 20-bit bus switch with low ON-State resistance. The bus switch creates no additional propagation delay. To minimize live-insertion noise, the device also precharges the B port to a user-selectable bias voltage (BIASV).

The switch is turned on by a single enable (\overline{OE}) input. When \overline{OE} is LOW, the switch is on and port A is connected to port B. When \overline{OE} is HIGH, the switch between port A and port B is open and the B port is precharged to BIASV through the equivalent of a 10k-ohm resistor.

Logic Diagram

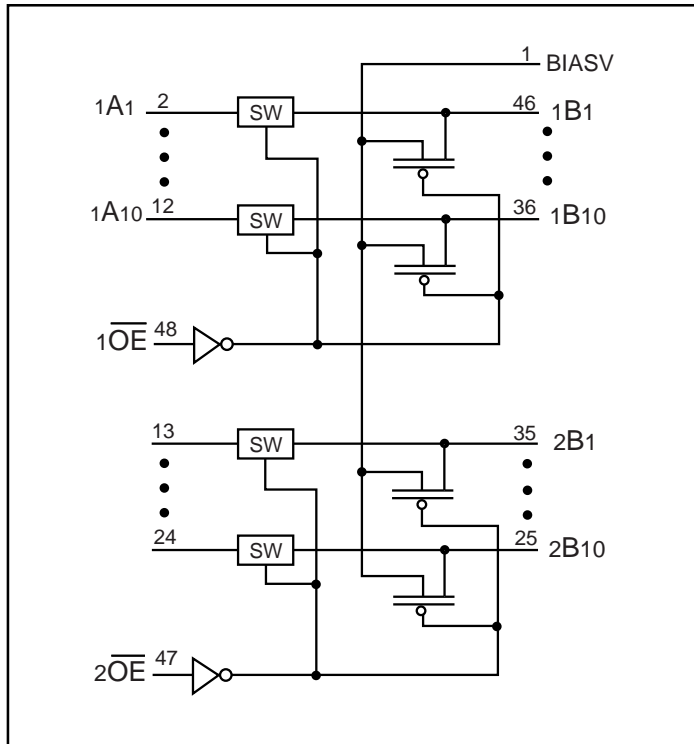

Truth Table

\overline{OE}	Function
L	A port = B port
H	A port = Z, A port = BIASV

Note:

1. H=High Voltage Level 2. L=Low Voltage Level

Product Pin Configuration

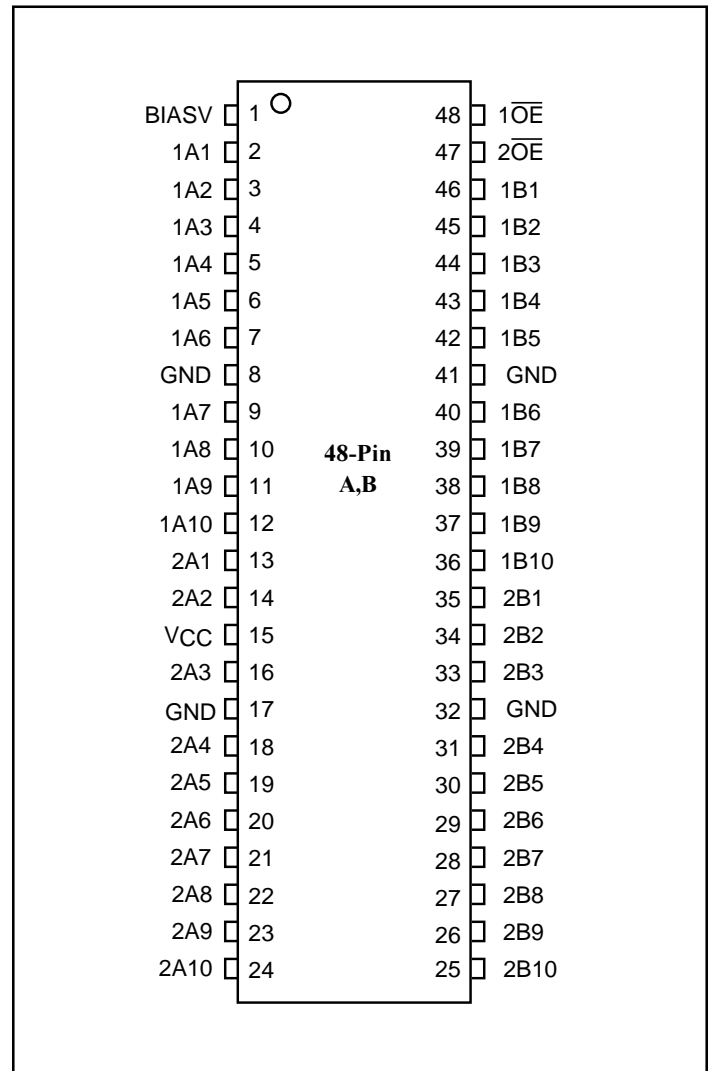

Absolute Maximum Ratings Over Free-Air Temperature Range*

(Above which the useful life may be impaired. For user guidelines, not tested.)

Storage Temperature.....	-65°C to +150°C
Supply Voltage Range	-0.5V to 4.6V
DC Input Voltage ⁽¹⁾	-0.5V to +5.5V
Input Clamp Current, I _{IK} (V _I <0)	-50mA
DC Output Current	120mA
Power Dissipation ⁽²⁾	0.5W

Note:

Stresses greater than those listed under MAXIMUM RATINGS may cause permanent damage to the device. This is a stress rating only and functional operation of the device at these or any other conditions above those indicated in the operational sections of this specification is not implied. Exposure to absolute maximum rating conditions for extended periods may affect reliability.

Notes:

1. The input and output negative-voltage ratings may be exceeded if the input and output clamp-current ratings are observed.
2. The maximum package power dissipation is calculated using a junction temperature of 150°C and a board trace length of 750 mils.

Recommended Operating Conditions

		Min.	Max.	Units
V _{CC}	Supply voltage	3.0	3.3	V
BIASV	Supply voltage	1.3	V _{CC}	
V _{IH}	High-level input voltage	2		
V _{IL}	Low-level input voltage		0.8	
T _A	Operating free-air temperature	-40	85	°C

Electrical Characteristics (Over Recommended Operating Free-Air Temperature Range)

Parameters	Description	Test Conditions	Min.	Typ. [‡]	Max.	Units	
V _{IK}	Clamp Diode Voltage	V _{CC} = 3.0V, I _{IN} = -18mA		-0.73	-1.2	V	
I _I	Input Current	V _{CC} = 3.6V, V _{IN} = V _{CC} or GND			±5	µA	
I _O	Output Current	V _{CC} = 3.0V, BIASV = 2.4V, V _O = 0	0.25			mA	
I _{CC}	Quiescent Power Supply Current	V _{CC} = 3.6V, I _O = 0, V _{IN} = V _{CC} or GND		260	850	µA	
ΔI _{CC}	Power Supply Current per Input	V _{CC} = 3.6V, One input at 2.7V Other at V _{CC} or GND			2.5	mA	
C _{IN}	Input Capacitance	V _{CC} = 0V		3.5		pF	
C _{OFF}	A/B Capacitance	V _{CC} = 0V, Switch Off		5.0			
R _{ON} [*]	Switch on Resistance	V _{CC} = 3.0V	V _{IN} = 0, I _{IN} = 64mA		5	8.5	Ω
			V _{IN} = 2.4V, I _{IN} = 30mA		8.0	15	
			V _{IN} = 2.4V, I _{IN} = 15mA		8.0	15	

Notes:

- * Measured by the voltage drop between the A and B terminals at the indicated current through the switch. On-state resistance is determined by the lower of the voltages of the two (A or B) terminals.
- ‡ This is the increase in supply current for control input.
- † All typical values are at V_{CC} = 3.3V, T_A = 25°C.

Switching Characteristics (Over Recommended Operating Free-air Temperature Range, $C_L = 50\text{pF}$)

Parameter	Test Conditions	From (Input)	To (Output)	Min.	Max.	Units
$t_{pD}^{(1)}$		A or B	B or A		0.25	ns
t_{pZH}	BIASV = GND	ON	A or B	1.5	6.5	
t_{pZL}	BIASV = 3V			1.5	6.5	
t_{pHZ}	BIASV = GND	ON	A or B	1.5	5.5	
t_{pLZ}	BIASV = 3V			1.5	5.5	

Note:

1. This parameter is warranted but not production tested. The propagation delay is based on the RC time constant of the typical on state resistance of the switch and a load capacitance of 50pF, when driven by an ideal voltage source (zero output impedance).

Parameter Measurements

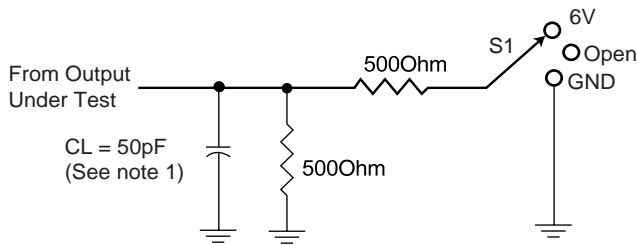

LOAD CIRCUIT

Test	S1
t_{pD}	Open
t_{pLZ}/t_{pZL}	6V
t_{pHZ}/t_{pZH}	GND

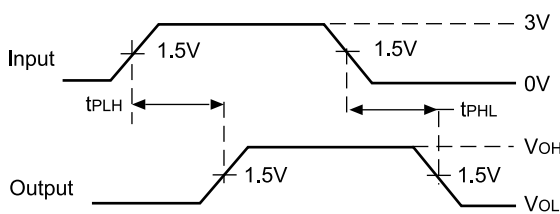

VOLTAGE WAVEFORMS
PROPAGATION DELAY TIMES

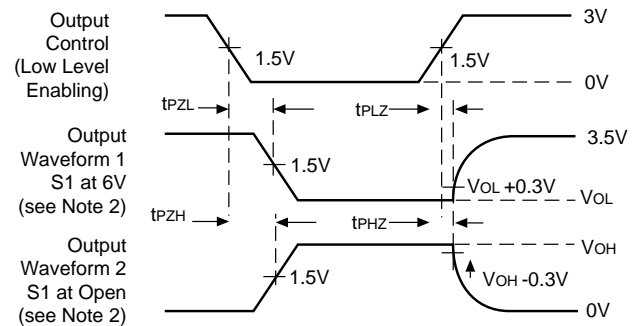

VOLTAGE WAVEFORMS
ENABLE AND DISABLE TIMES

Notes:

1. C_L includes probe and jig capacitance.
2. Waveform 1 is for an output with internal conditions such that the output is LOW except when disabled by the output control. Waveform 2 is for an output with internal conditions such that the output is HIGH except when disabled by the output control.
3. All input pulses are supplied by generators having the following characteristics: $PRR < 10\text{MHz}$, $Z_O = 50\Omega$, $t_R \leq 2.5\text{ns}$, $t_F \leq 2.5\text{ns}$.
4. The outputs are measured one at a time with one transition per measurement.
5. t_{pLZ} and t_{pHZ} are the same as t_{pDIS} .
6. t_{pZL} and t_{pZH} are the same as t_{pEN} .
7. t_{pLH} and t_{pHL} are the same as t_{pD} .

48-Pin TSSOP (A) Package

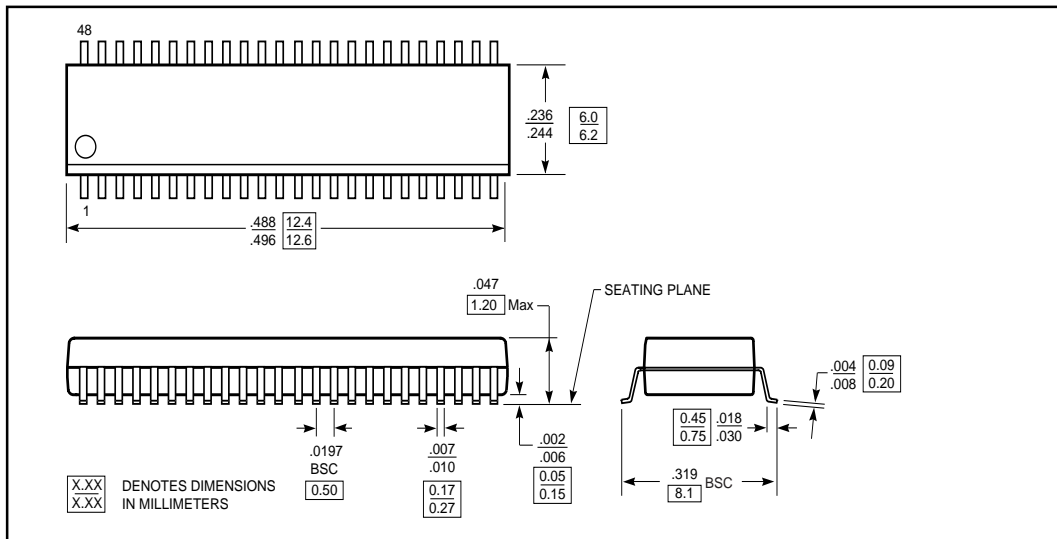

48-Pin BQSOP (B) Package

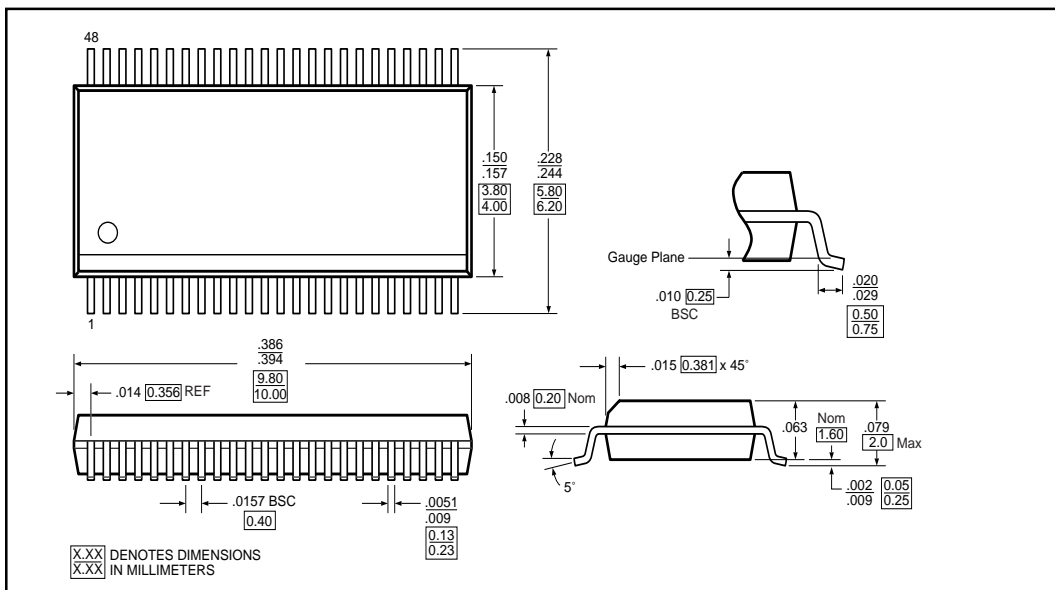

Ordering Information

Part	Pin - Package	Width	Temperature
PI3C16215A	48-TSSOP (A48)	240-mil	-40°C to +85°C
PI3C16215B	48-BQSOP (B48)	240-mil	

Applications Information

Logic Inputs

The logic control inputs can be driven up to +3.6V regardless of the supply voltage. For example, given a +3.3V supply, IN may be driven low to 0V and high to 3.6V. Driving IN Rail-to-Rail® minimizes power consumption.

Power-Supply Sequencing

Proper power-supply sequencing is recommended for all CMOS devices. Always apply V_{CC} before applying V_{BIAS} and signals to input/output or control pins.

Rail-to-Rail is a registered trademark of Nippon Motorola, Ltd