

3.3V, High Bandwidth, 16:32-Bit, PCI Hot-Plug Mux/Demux Bus Switch

Product Features

- R_{ON} is 9 ohms typical
- Pullup on B1 and B2 ports
- Low Power: 70 μ A typical
- Industrial Operation Temperature: -40°C to +85°C
- Near Zero propagation delay
- Switching speed: 5ns max.
- Channel on capacitance: 12pF typical
- V_{CC} Operating Range: +2V to +3.6V
- >100 MHz bandwidth (or clock rate) at 20pF load capacitance
- Package: 56-pin TSSOP (A)

Product Description

Pericom Semiconductor's PI3C series of logic circuits are produced using the Company's advanced submicron CMOS technology, achieving industry leading performance.

The PI3C32160 is a 16- to 32-bit demultiplexer bus switch. Industry leading advantages include a propagation delay of 500ps, resulting from 9 ohms channel resistance and low I/O capacitance. A port demultiplexes to either 1B or 2B and the switch is bidirectional.

Application

PCI Hot Plugging.

Logic Block Diagram

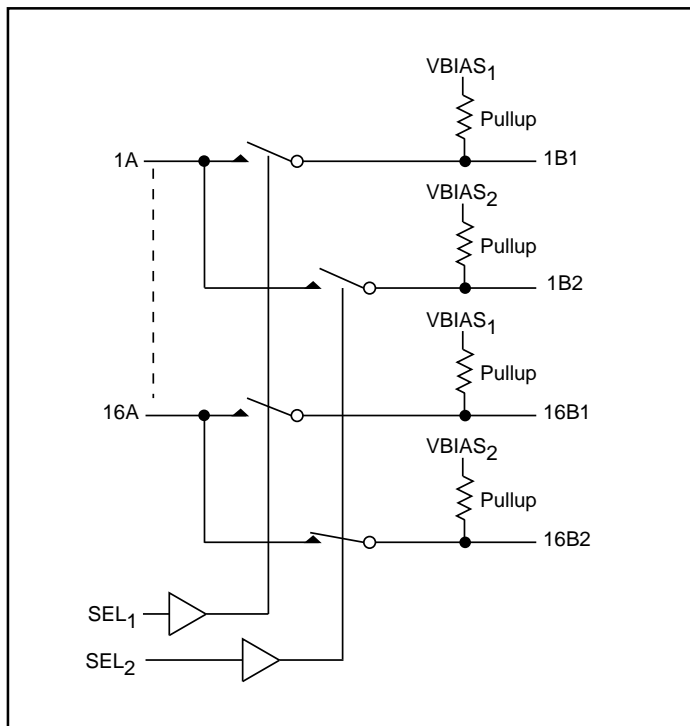

Function	SEL ₁	SEL ₂
nA to nB ₁	L	H
nA to nB ₂	H	L
nA to nB ₁ and nB ₂	L	L
nB ₁ , nB ₂ = V _{BIAS}	H	H

Pin Description

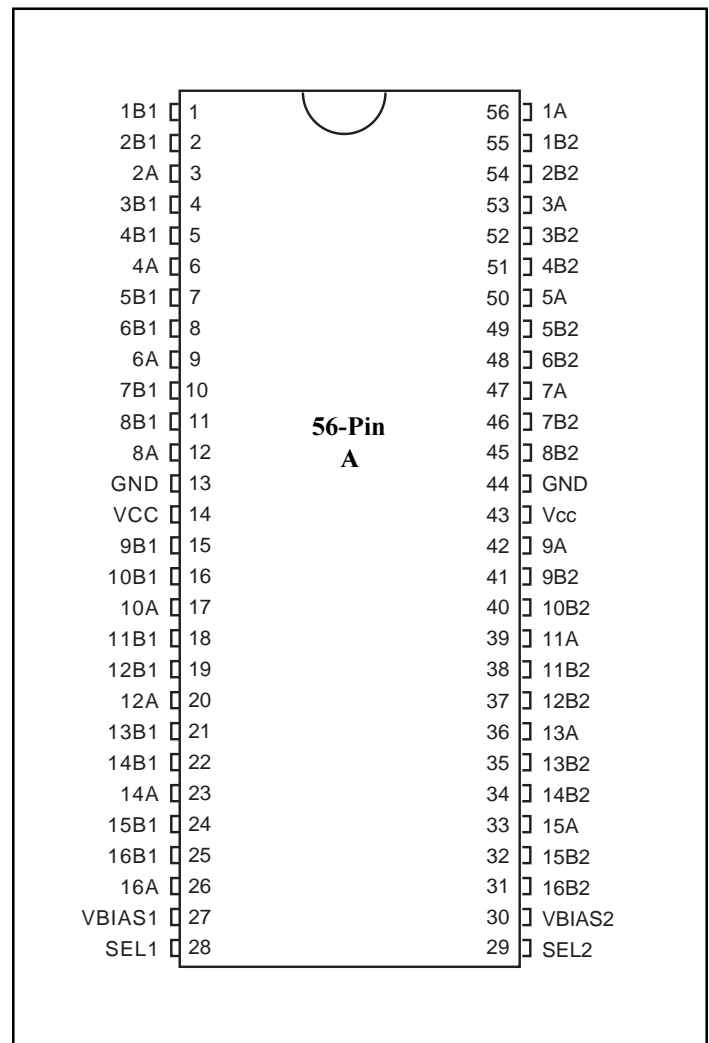

Maximum Ratings

(Above which the useful life may be impaired. For user guidelines, not tested.)

Storage Temperature	-65°C to +150°C
Ambient Temperature with Power Applied	-40°C to +85°C
Supply Voltage to Ground Potential	-0.5V to +4.6V
DC I/O Voltage	-0.5V to 5.5V
DC Output Current	120mA
Power Dissipation	0.5W

Note:

Stresses greater than those listed under MAXIMUM RATINGS may cause permanent damage to the device. This is a stress rating only and functional operation of the device at these or any other conditions above those indicated in the operational sections of this specification is not implied. Exposure to absolute maximum rating conditions for extended periods may affect reliability.

DC Electrical Characteristics (Over the Operating Range, $T_A = -40^\circ\text{C}$, $V_{CC} = 3.3\text{V} \pm 10\%$, $V_{BIAS} = 1.3\text{V}$ to V_{CC})

Parameters	Description	Test Conditions ⁽¹⁾	Min.	Typ ⁽²⁾	Max.	Units
V_{IH}	Input HIGH Voltage	Guaranteed Logic HIGH Level	2.0	—	—	V
V_{IL}	Input LOW Voltage	Guaranteed Logic LOW Level	-0.5	—	0.8	V
I_{IH}	Input HIGH Current	$V_{CC} = \text{Max.}, V_{IN} = V_{CC}$	—	—	± 1	μA
I_{IL}	Input LOW Current	$V_{CC} = \text{Max.}, V_{IN} = \text{GND}$	—	—	± 1	μA
I_{OZH}	High Impedance Output Current	$A = 0\text{V}$ or $V_{CC} \text{ max.}, V_{BIAS1} = V_{BIAS2} = V_{CC} \text{ max.}$	—	—	± 1	μA
I_O	Pullup Current	$B = 0\text{V}$ or $V_{CC} \text{ max.}, V_{BIAS1} = V_{BIAS2} = V_{CC} \text{ max.}$	-0.2	—	-2	mA
V_{IK}	Clamp Diode Voltage	$V_{CC} = \text{Min.}, I_{IN} = -18\text{mA}$	—	-0.73	-1.2	V
R_{ON}	Switch ON Resistance ⁽⁴⁾	$V_{CC} = \text{Min.}, V_{IN} = 0.0\text{mA}$ $I_{ON} = 48\text{mA}$ or 64mA	—	9.0	12	Ω
		$V_{CC} = \text{Min.}, I_{IN} = 2.4\text{V}$ $I_{ON} = 15\text{mA}$	—	16	23	Ω

Capacitance ($T_A = 25^\circ\text{C}$, $f = 1\text{MHz}$)

Parameters ⁽⁵⁾	Description	Test Conditions	Typ.	Max.	Units
C_{IN}	Input Capacitance	$V_{IN} = 0\text{V}$	3.5	—	pF
C_{OFF}	A/B Capacitance, Switch Off		4.0	—	
C_{ON}	A/B Capacitance, Switch Off		12.0	—	

Notes:

- For Max. or Min. conditions, use appropriate value specified under Electrical Characteristics for the applicable device type.
- Typical values are at $V_{CC} = 3.3\text{V}$, $T_A = 25^\circ\text{C}$ ambient and maximum loading.
- Not more than one output should be shorted at one time. Duration of the test should not exceed one second.
- Measured by the voltage drop between A and B pins at indicated current through the switch. ON resistance is determined by the lower of the voltages on the two (A & B) pins.
- This parameter is determined by device characterization but is not production tested.

Power Supply Characteristics

Parameters	Description	Test Conditions ⁽¹⁾	Min.	Typ. ⁽²⁾	Max.	Units
I_{CC}	Quiescent Power Supply Current	$V_{CC} = \text{Max.}$ $V_{IN} = \text{GND or } V_{CC}$	—	260	850	μA
ΔI_{CC}	Supply Current per Input @ TTL HIGH	$V_{CC} = \text{Max.}$ $V_{IN} = 3.0\text{V}^{(3)}$	—	—	750	

Notes:

1. For Max. or Min. conditions, use appropriate value specified under Electrical Characteristics for the applicable device.
2. Typical values are at $V_{CC} = 3.3\text{V}$, $+25^\circ\text{C}$ ambient.
3. Per TTL driven input (control inputs only); A and B pins do not contribute to I_{CC} .

Switching Characteristics over Operating Range

Parameters	Description	Conditions ⁽¹⁾	PI3C32160		
			Com		
			Min.	Max.	Units
t_{PLH} t_{PHL}	Propagation Delay ^(2,3) A_X to B_X , B_X to A_X	$C_L = 50\text{pF}$ $R_L = 500\Omega$	—	0.50	ns
t_{PZH} t_{PZL}	Bus Enable Time $\overline{B}E_X$ to A_X or B_X	$C_L = 50\text{pF}$ $R_L = 500\Omega$ $R = 500\Omega$	1.5	6.5	
t_{PHZ} t_{PLZ}	Bus Disable Time $\overline{B}E_X$ to A_X or B_X		1.5	5.5	

Notes:

1. See test circuit and waveforms.
2. This parameter is guaranteed but not tested on Propagation Delays.
3. The bus switch contributes no propagational delay other than the RC delay of the ON resistance of the switch and the load capacitance. The time constant for the switch alone is of the order of 0.25ns for 50pF load. Since this time constant is much smaller than the rise/fall times of typical driving signals, it adds very little propagational delay to the system. Propagational delay of the bus switch when used in a system is determined by the driving circuit on the driving side of the switch and its interaction with the load on the driven side.

56-Pin TSSOP (A) Package

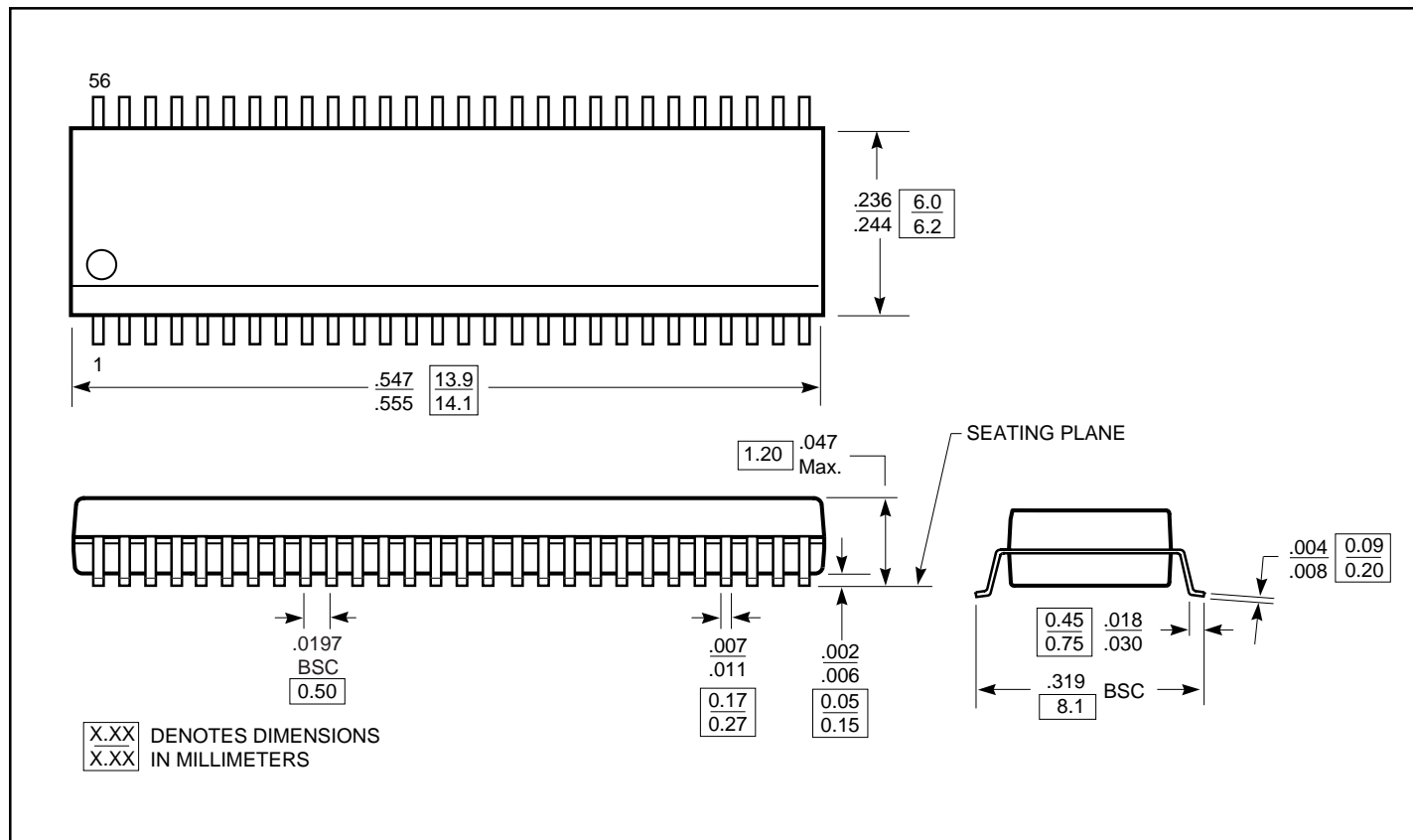

Ordering Information

Part	Pin - Package	Width	Temperature
PI3C32160A	56 - TSSOP (A)	240-mil	0°C to 85°C

Applications Information

Logic Inputs

The logic control inputs can be driven up to +3.6V regardless of the supply voltage. For example, given a +3.3V supply, the output enables or select pins may be driven low to 0V and high to 3.6V. Driving IN Rail-to-Rail[®] minimizes power consumption.

Power-Supply Sequencing

Proper power-supply sequencing is recommended for all CMOS devices. It is recommended to always apply V_{CC} before applying signals to input/output or control pins.

Hot Insertion

For Datacom and Telecom applications that have 10 or more volts passing through the backplane or system bus, a high voltage from the power supply may be seen at the device input pins during Hot Insertion. The PI3Cxxx devices have maximum limits of 5.5V and 120mA for 20ns. If the power is higher or applied for a longer period of time or repeatedly reaches the maximum limits, the devices can be damaged.

Rail-to-Rail is a registered trademark of Nippon Motorola, Ltd