

### 2.5V/3.3V, High Bandwidth, Hot Insertion 16-Bit, 2-Port, Bus Switch

#### Features

- Near-Zero propagation delay
- 5-ohm switches connect inputs to outputs
- Permits Hot Insertion
- 5V I/O Tolerant
- 2.5V Supply Voltage Operation
- Rail-to-Rail 3.3V or 2.5V Switching
- High Bandwidth Operation (>400 MHz)
- Packaging (Pb-free & Green available)
  - 40-pin, 150-mil-wide plastic BQSOP (B)

#### Description

Pericom Semiconductor's PI3C32X245 is a 2.5V or 3.3V 16-bit, 2-port bus switch designed with a low On-Resistance (5-ohm) allowing inputs to be connected directly to outputs. The bus switch creates no additional propagational delay or additional ground bounce noise. The switches are turned ON by the Bus Enable ( $\overline{BE}_N$ ) input signal. It is very useful in switching signals that have high bandwidth (>400MHz).

#### Block Diagram

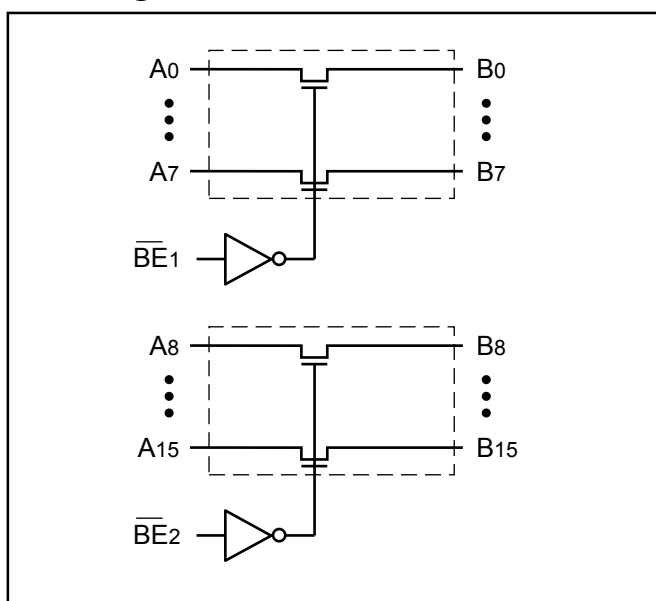

#### Truth Table<sup>(1)</sup>

Function	$\overline{BE}_N$	A0–15
Disconnect	H	Hi-Z
Connect	L	B0–15

#### Note:

1. H = High Voltage Level  
L = Low Voltage Level  
Hi-Z = High Impedance

#### Pin Configuration

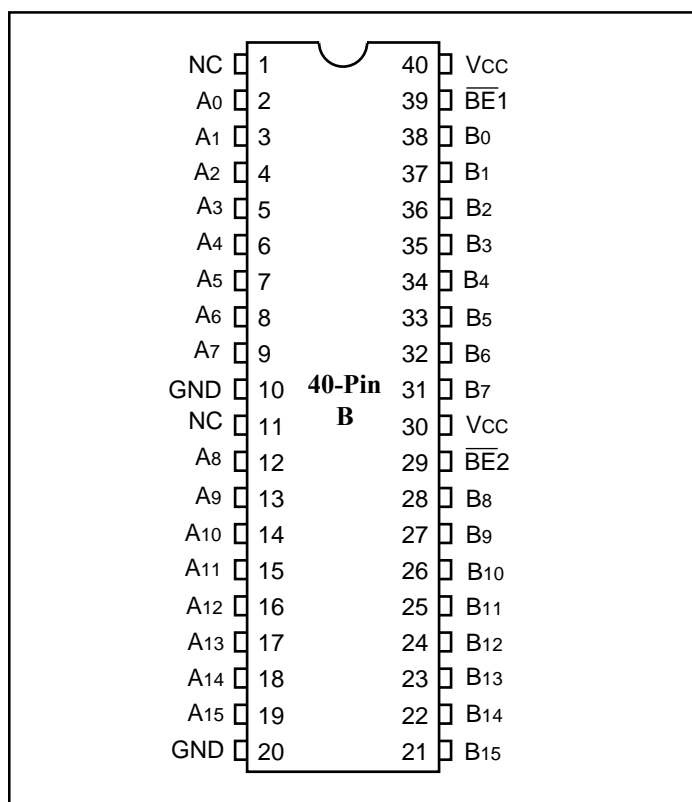

#### Pin Description

Pin Name	I/O	Description
$\overline{BE}_N$	I	Bus Enable Input (Active LOW)
A0–A15	I/O	Bus A
B0–B15	I/O	Bus A

### Maximum Ratings

(Above which the useful life may be impaired. For user guidelines, not tested.)

Storage Temperature .....	-65°C to +150°C
Ambient Temperature with Power Applied .....	-40°C to +85°C
Supply Voltage to Ground Potential (Inputs & V <sub>CC</sub> Only) .....	-0.5V to +4.6V
Supply Voltage to Ground Potential (Outputs & D/O Only) .....	-0.5V to +4.6V
DC Input Voltage .....	-0.5V to +5.5V
DC Output Current .....	120mA
Power Dissipation .....	0.5W

**Note:**

Stresses greater than those listed under MAXIMUM RATINGS may cause permanent damage to the device. This is a stress rating only and functional operation of the device at these or any other conditions above those indicated in the operational sections of this specification is not implied. Exposure to absolute maximum rating conditions for extended periods may affect reliability.

### DC Electrical Characteristics (Over Operating Range, T<sub>A</sub> = -40°C to +85°C, V<sub>CC</sub> = 3.3V ±10%)

Parameters	Description	Test Conditions <sup>(1)</sup>	Min.	Typ. <sup>(2)</sup>	Max.	Units
V <sub>IH</sub>	Input HIGH Voltage	Guaranteed Logic HIGH Level	2.0			V
V <sub>IL</sub>	Input LOW Voltage	Guaranteed Logic LOW Level	-0.5		0.8	
I <sub>IH</sub>	Input HIGH Current	V <sub>CC</sub> = Max., V <sub>IN</sub> = V <sub>CC</sub>			±1	µA
I <sub>IL</sub>	Input LOW Current	V <sub>CC</sub> = Max., V <sub>IN</sub> = GND			±1	
I <sub>OZH</sub>	High Impedance Output Current	0 ≤ A, B ≤ V <sub>CC</sub>			±1	
V <sub>IK</sub>	Clamp Diode Voltage	V <sub>CC</sub> = Min., I <sub>IN</sub> = -18mA		-0.73	-1.2	V
R <sub>ON</sub>	Switch On Resistance <sup>(4)</sup>	V <sub>CC</sub> = Min., V <sub>IN</sub> = 0.0V, I <sub>ON</sub> = 48mA V <sub>CC</sub> = Min., V <sub>IN</sub> = 2.4V, I <sub>ON</sub> = 15mA		5 8	7 15	Ω

### Capacitance (T<sub>A</sub> = 25°C, f = 1 MHz)

Parameters <sup>(5)</sup>	Description	Test Conditions	Typ.	Units
C <sub>IN</sub>	Input Capacitance	V <sub>IN</sub> = 0V	3.5	pF
C <sub>OFF</sub>	A/B Capacitance, Switch Off	V <sub>IN</sub> = 0V	5.0	
C <sub>ON</sub>	A/B Capacitance, Switch On	V <sub>IN</sub> = 0V	10.0	

**Notes:**

1. For Max. or Min. conditions, use appropriate value specified under Electrical Characteristics for the applicable device type.
2. Typical values are at V<sub>CC</sub> = 3.3V, T<sub>A</sub> = 25°C ambient and maximum loading.
3. Not more than one output should be shorted at one time. Duration of the test should not exceed one second.
4. Measured by the voltage drop between A and B pin at indicated current through the switch. ON resistance is determined by the lower of the voltages on the two (A,B) pins.
5. This parameter is determined by device characterization but is not production tested.

### Power Supply Characteristics

Parameters	Description	Test Conditions <sup>(1)</sup>		Min.	Typ. <sup>(2)</sup>	Max.	Units
I <sub>CC</sub>	Quiescent Power Supply Current	V <sub>CC</sub> = Max.	V <sub>IN</sub> = GND or V <sub>CC</sub>		0.5	1.0	mA
ΔI <sub>CC</sub>	Supply Current per Input HIGH	V <sub>CC</sub> = Max.	V <sub>IN</sub> = 3.0V <sup>(3)</sup>			2.5	

**Notes:**

1. For Max. or Min. conditions, use appropriate value specified under Electrical Characteristics for the applicable device.
2. Typical values are at V<sub>CC</sub> = 3.3V, +25°C ambient.
3. Per driven input (control input only); A and B pins do not contribute to ΔI<sub>CC</sub>.

### Switching Characteristics over 3.3V Operating Range

Parameters	Description	Conditions	PI3C32X245		Units
			Com.		
			Min.	Max.	
t <sub>PLH</sub> t <sub>PHL</sub>	Propagation Delay <sup>(2,3)</sup> Ax to Bx	C <sub>L</sub> = 50pF R <sub>L</sub> = 500ohm		0.25	ns
t <sub>PZH</sub> t <sub>PZL</sub>	Bus Enable Time BE to Ax or Bx	C <sub>L</sub> = 50pF R <sub>L</sub> = 500ohm	1.5	6.5	
t <sub>PHZ</sub> t <sub>PLZ</sub>	Bus Disable Time BE to Ax or Bx	R = 500ohm	1.5	5.5	

### Switching Characteristics over 2.5V Operating Range

Parameters	Description	Conditions	PI3C32X245		Units
			Com.		
			Min.	Max.	
t <sub>PLH</sub> t <sub>PHL</sub>	Propagation Delay <sup>(2,3)</sup> Ax to Bx	C <sub>L</sub> = 50pF R <sub>L</sub> = 500ohm		0.25	ns
t <sub>PZH</sub> t <sub>PZL</sub>	Bus Enable Time BE to Ax or Bx	C <sub>L</sub> = 50pF R <sub>L</sub> = 500ohm	1.5	9.8	
t <sub>PHZ</sub> t <sub>PLZ</sub>	Bus Disable Time BE to Ax or Bx	R = 500ohm	1.5	8.3	

**Notes:**

1. See test circuit and waveforms.
2. This parameter is guaranteed but not tested on Propagation Delays.
3. The bus switch contributes no propagational delay other than the RC delay of the ON resistance of the switch and the load capacitance. The time constant for the switch alone is of the order of 0.25ns for 50pF load. Since this time constant is much smaller than the rise/fall times of typical driving signals, it adds very little propagational delay to the system. Propagational delay of the bus switch when used in a system is determined by the driving circuit on the driving side of the switch and its interaction with the load on the driven side.

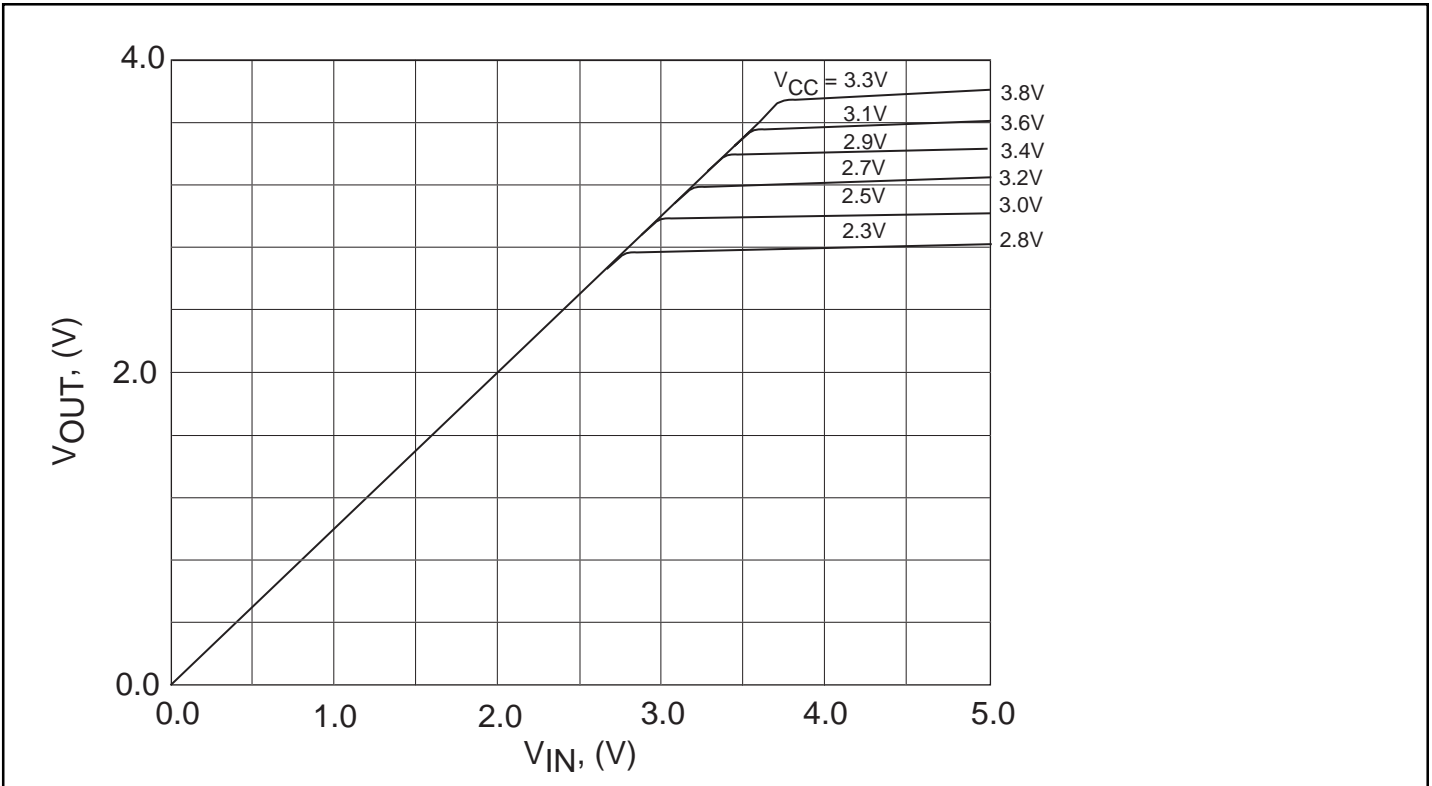

**Output Voltage vs. Input Voltage over Various Supply Voltages**

**Packaging Mechanical: 40-pin BQSOP (B)**

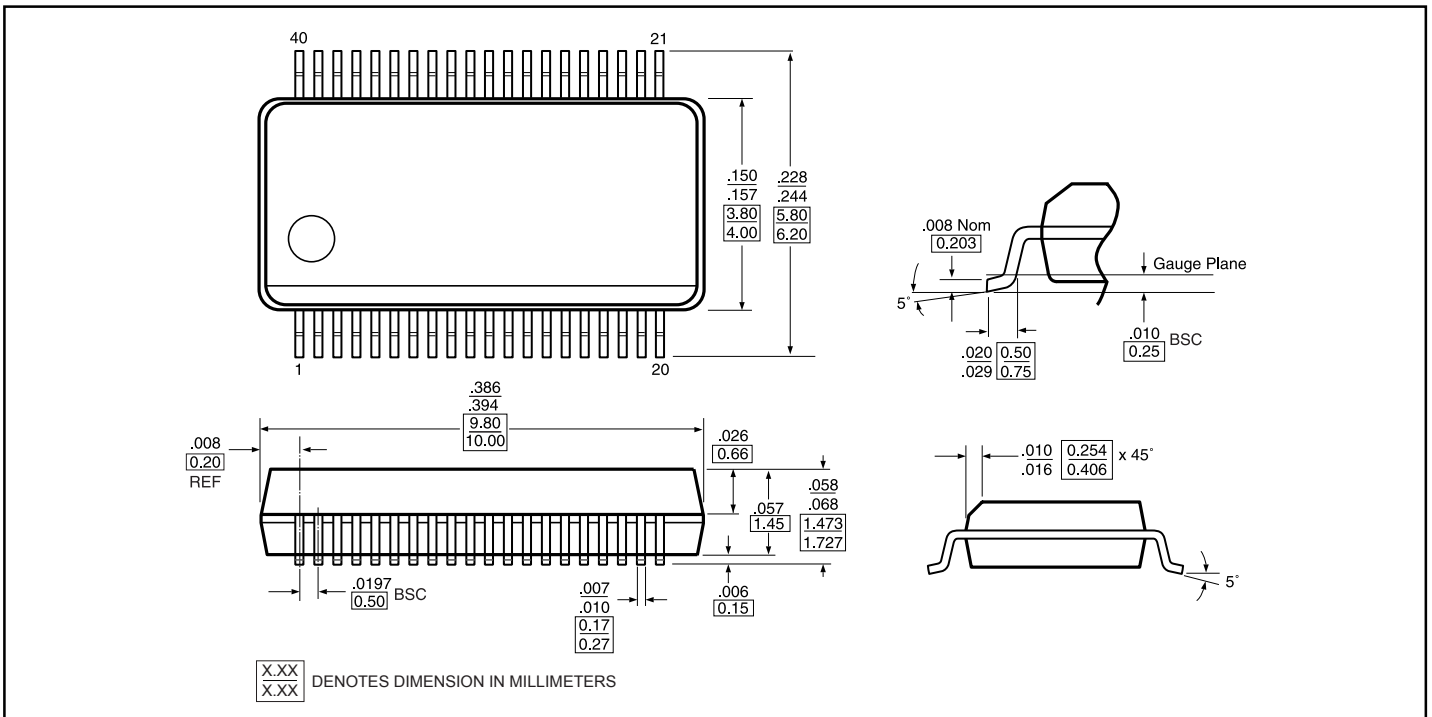



**Ordering Information**

<b>Ordering Code</b>	<b>Package Code</b>	<b>Package Type</b>
PI3C32X245B	B	40-pin BQSOP
PI3C32X245BE	B	Pb-free & Green, 40-pin BQSOP

**Notes:**

1. Thermal characteristics can be found on the company web site at [www.pericom.com/packaging/](http://www.pericom.com/packaging/)