

Features

- Near-zero propagation delay
- 5Ω switches connect inputs to outputs
- High signal passing bandwidth (500 MHz)
- Beyond Rail-to-Rail switching
- 5V I/O tolerant with 3.3V supply in OFF and ON state
- 2.5V and 3.3V supply voltage operation
- Hot Insertion Capable
- Industrial Operating Temperature: -40°C to +85°C
- 2kV ESD Protection (human body model)
- Latch-up Performance: >250mA per JESD17
- Packaging (Pb-free & Green Available):
 - 8-pin TSSOP (L)

Description

The PI3CH3306 is a low voltage, 2-channel switch designed with fast individual enables. The switch introduces no additional propagation delay or additional ground bounce noise.

The PI3CH3306 device has active LOW enables. It is very useful in switching signals that have high bandwidth (500 MHz).

Applications

- High Bandwidth Data Switching
- Hot-Docking
- Analog Signal Switching
- Differential Signal Switching

Block Diagram

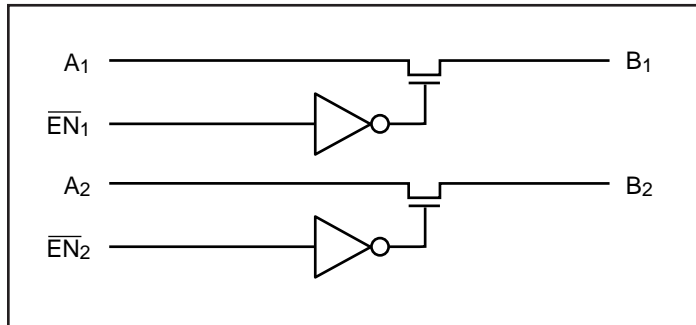

Pin Configuration

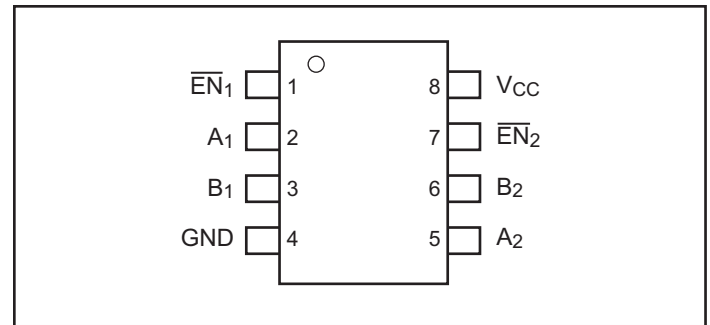

Truth Table⁽¹⁾

\overline{EN}_x	A_x	B_x	V_{CC}	Function
X	Hi-Z	Hi-Z	GND	Disconnect
H	Hi-Z	Hi-Z	V_{CC}	Disconnect
L	B_x	A_x	V_{CC}	Connect

Notes:

1. H = High Voltage Level, L = Low Voltage Level, Hi-Z = High-Impedance

Pin Description

Pin Name	Description
\overline{EN}_x	Switch Enable
$A_2 - A_1$	A Ports
$B_2 - B_1$	B Ports
GND	Ground
V_{CC}	Power

Maximum Ratings

(Above which the useful life may be impaired. For user guidelines, not tested.)

Storage Temperature	-65°C to +150°C
Ambient Temperature with Power Applied	-40°C to +85°C
Supply Voltage to Ground Potential	-0.5V to +4.6V
DC Input Voltage	-0.5V to +6.0V
DC Output Current.....	120mA
Power Dissipation	0.5W

Note:

Stresses greater than those listed under MAXIMUM RATINGS may cause permanent damage to the device. This is a stress rating only and functional operation of the device at these or any other conditions above those indicated in the operational sections of this specification is not implied. Exposure to absolute maximum rating conditions for extended periods may affect reliability.

DC Electrical Characteristics, 3.3V Supply (Over Operating Range, $T_A = -40^{\circ}\text{C}$ to $+85^{\circ}\text{C}$, $V_{CC} = 3.3\text{V} \pm 10\%$)

Parameters	Description	Test Conditions ⁽¹⁾	Min.	Typ. ⁽²⁾	Max.	Units
V_{IH}	Input HIGH Voltage	Guaranteed Logic HIGH Level	2			V
V_{IL}	Input LOW Voltage	Guaranteed Logic LOW Level	-0.5		0.8	
V_{IK}	Clamp Diode Voltage	$V_{CC} = \text{Min.}, I_{IN} = -18\text{mA}$		-1.3	-1.8	
I_{IH}	Input HIGH Current	$V_{CC} = \text{Max.}, V_{IN} = V_{CC}$			± 1	μA
I_{IL}	Input LOW Current	$V_{CC} = \text{Max.}, V_{IN} = \text{GND}$			± 1	
I_{OZH}	High-Impedance Current ⁽³⁾	$0 \leq A, B \leq V_{CC}$			± 1	
R_{ON}	Switch On-resistance ⁽⁴⁾	$V_{CC} = \text{Min.}, V_{IN} = 0.0\text{V}$ $I_{ON} = -48\text{mA}$ or -64mA		4	6	Ω
		$V_{CC} = \text{Min.}, V_{IN} = 3.6\text{V}, I_{ON} = -15\text{mA}$		5	8	

Notes:

1. For Max. or Min. conditions, use appropriate value specified under Electrical Characteristics for the applicable device type.
2. Typical values are at $V_{CC} = 3.3\text{V}$, $T_A = 25^{\circ}\text{C}$ ambient and maximum loading.
3. Not more than one output should be shorted at one time. Duration of the test should not exceed one second.
4. Measured by the voltage drop between A and B pin at indicated current through the switch. On-Resistance is determined by the lower of the voltages on the two (A,B) pins.

DC Electrical Characteristics, 2.5V Supply (Over Operating Range, $T_A = -40^{\circ}\text{C}$ to $+85^{\circ}\text{C}$, $V_{CC} = 2.5\text{V} \pm 10\%$)

Parameters	Description	Test Conditions ⁽¹⁾	Min.	Typ. ⁽²⁾	Max.	Units
V_{IH}	Input HIGH Voltage	Guaranteed Logic HIGH Level	1.8		$V_{CC} + 0.3$	V
V_{IL}	Input LOW Voltage	Guaranteed Logic LOW Level	-0.3		0.8	
V_{IK}	Clamp Diode Voltage	$V_{CC} = \text{Max.}, I_{IN} = -6\text{mA}$		-0.7	-1.8	
I_{IH}	Input HIGH Current	$V_{CC} = \text{Max.}, V_{IN} = V_{CC}$			± 1	μA
I_{IL}	Input LOW Current	$V_{CC} = \text{Max.}, V_{IN} = \text{GND}$			± 1	
I_{OZH}	High Impedance Current ⁽³⁾	$0 \leq A, B \leq V_{CC}$			± 1	
R_{ON}	Switch On Resistance ⁽⁴⁾	$V_{CC} = \text{Min.}, V_{IN} = 0.0\text{V}, I_{ON} = -48\text{mA}$		6	8	Ω
		$V_{CC} = \text{Min.}, V_{IN} = 2.25\text{V}, I_{ON} = -15\text{mA}$		7	14	

Notes:

- For Max. or Min. conditions, use appropriate value specified under Electrical Characteristics for the applicable device type.
- Typical values are at $V_{CC} = 3.3\text{V}$, $T_A = 25^{\circ}\text{C}$ ambient and maximum loading.
- Not more than one output should be shorted at one time. Duration of the test should not exceed one second.
- Measured by the voltage drop between A and B pin at indicated current through the switch. On-Resistance is determined by the lower of the voltages on the two (A,B) pins.

Capacitance ($T_A = 25^{\circ}\text{C}$ $f = 1\text{MHz}$)

Parameters ⁽¹⁾	Description	Test Conditions	Typ.	Units
C_{IN}	Input Capacitance	$V_{IN} = 0\text{V}$	3.5	pF
C_{OFF}	A/B Capacitance, Switch Off		3.5	
C_{ON}	A/B Capacitance, Switch On		7.0	

Notes:

- This parameter is determined by device characterization but is not production tested.

Power Supply Characteristics

Parameters	Description	Test Conditions ⁽¹⁾	Min.	Typ. ⁽²⁾	Max.	Units
I_{CC}	Quiescent Power Supply Current	$V_{CC} = 3.6\text{V}, V_{IN} = \text{GND or } V_{CC}$			0.8	mA

Notes:

- For Max. or Min. conditions, use appropriate value specified under Electrical Characteristics for the applicable device.
- Typical values are at $V_{CC} = 3.3\text{V}$, $+25^{\circ}\text{C}$ ambient.

Dynamic Electrical Characteristics Over the Operating Range ($T_A = -40^\circ$ to $+85^\circ$, $V_{CC} = 3.3V \pm 10\%$)

Parameter	Description	Test Condition	Min.	Typ.	Max.	Units
X _{TALK}	Crosstalk	See Test Diagram		-60		dB
O _{IRR}	Off-Isolation	See Test Diagram		-60		
BW	-3dB Bandwidth	See Test Diagram	200	500		MHz

Switching Characteristics over 3.3V Operating Range

Parameters	Description	Conditions ⁽¹⁾	Com.			Units
			Min.	Typ.	Max.	
t _{PLH} t _{PHL}	Propagation Delay ^(2,3) Ax to Bx, Bx to Ax	See Test Diagram			0.3	ns
t _{PZH} t _{PZL}	Enable Time \overline{EN}_x to Ax or Bx	See Test Diagram	1.5		9.0	
t _{PHZ} t _{PLZ}	Disable Time \overline{EN}_x to Ax or Bx		1.5		9.0	

Notes:

1. See test circuit and waveforms.
2. This parameter is guaranteed but not tested on Propagation Delays.
3. The switch contributes no propagational delay other than the RC delay of the On-Resistance of the switch and the load capacitance. The time constant for the switch alone is of the order of 0.25ns for 10pF load. Since this time constant is much smaller than the rise/fall times of typical driving signals, it adds very little propagational delay to the system. Propagational delay of the switch when used in a system is determined by the driving circuit on the driving side of the switch and its interaction with the load on the driven side.

Switching Characteristics over 2.5V Operating Range

Parameters	Description	Conditions ⁽¹⁾	Com.		Units
			Min.	Max.	
t _{PLH} t _{PHL}	Propagation Delay ^(2,3) Ax to Bx, Bx to Ax	See Test Diagram		0.3	ns
t _{PZH} t _{PZL}	Enable Time \overline{EN}_x to Ax or Bx	See Test Diagram	1.5	15.0	
t _{PHZ} t _{PLZ}	Disable Time \overline{EN}_x to Ax or Bx		1.5	12.0	

Notes:

1. See test circuit and waveforms.
2. This parameter is guaranteed but not tested on Propagation Delays.
3. The switch contributes no propagational delay other than the RC delay of the On-Resistance of the switch and the load capacitance. The time constant for the switch alone is of the order of 0.25ns for 10pF load. Since this time constant is much smaller than the rise/fall times of typical driving signals, it adds very little propagational delay to the system. Propagational delay of the switch when used in a system is determined by the driving circuit on the driving side of the switch and its interaction with the load on the driven side.

Test Circuit for Electrical Characteristics

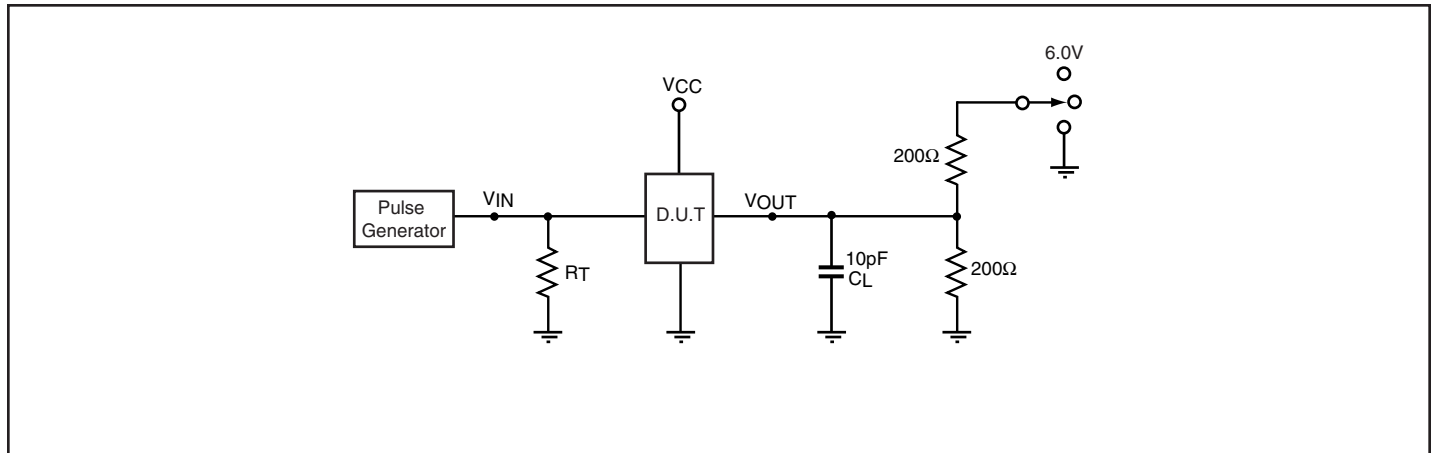

Notes:

- C_L = Load capacitance: includes jig and probe capacitance.
- R_T = Termination resistance: should be equal to Z_{OUT} of the Pulse Generator.
- Waveform 1 is for an output with internal conditions such that the output is low except when disabled by the output control.
- Waveform 2 is for an output with internal conditions such that the output is high except when disabled by the output control.
- All input impulses are supplied by generators having the following characteristics: $PRR \leq 10$ MHz, $Z_O = 50$ -ohm, $t_R \leq 2.5$ ns, $t_F \leq 2.5$ ns.
- The outputs are measured one at a time with one transition per measurement.

Switch Positions

Test	Switch
t_{PLZ} , t_{PZL}	6.0V
t_{PHZ} , t_{PZH}	GND
Prop Delay	Open

Test Circuit for Dynamic Electrical Characteristics

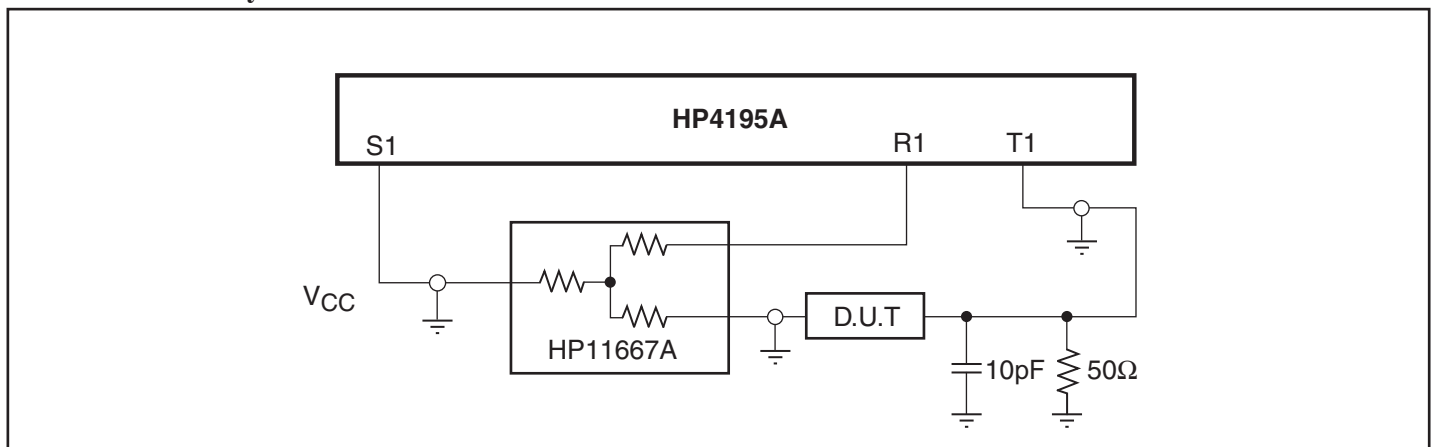

Switching Waveforms

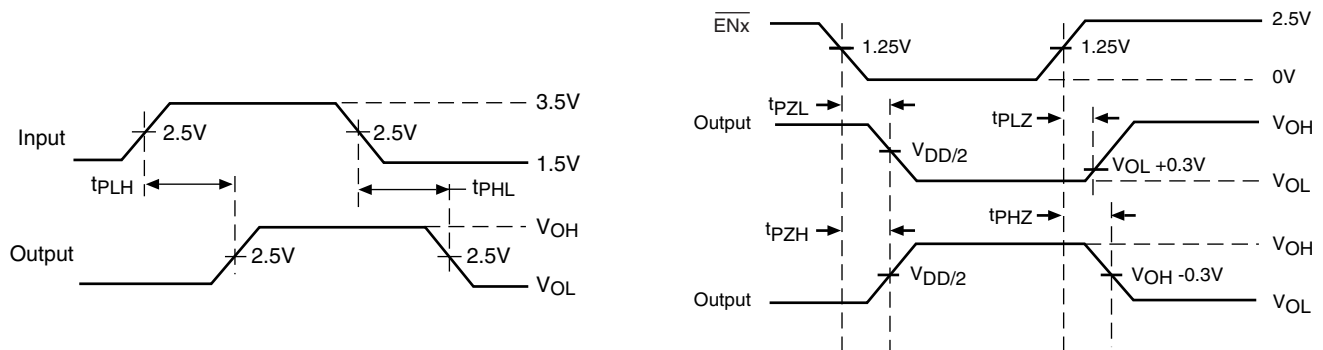

Voltage Waveforms Enable and Disable Times

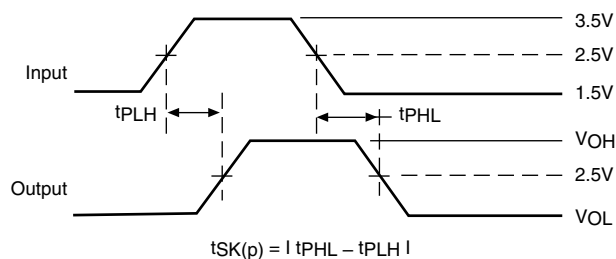

Pulse Skew - $t_{SK(p)}$

Applications Information

Logic Inputs

The logic control inputs can be driven up to 3.6V regardless of the supply voltage. For example, given a +3.3V supply, \overline{EN} may be driven LOW to 0V and HIGH to 3.6V. Driving \overline{EN} Rail-to-Rail® minimizes power consumption.

Power Supply-Sequencing

Proper power supply sequencing is recommended for all CMOS devices. Always apply V_{CC} before applying signals to the input/output or control pins.

Hot Insertion

For Datacom and Telecom applications that have ten or more volts passing through the backplane, a high voltage from the power supply may be seen at the device input pins during hot insertion. The PI3CHxx devices have maximum limits of 6V and 120mA for 20ns. If the power is higher or applied for a longer time or repeatedly reaches the maximum limits, the devices can be damaged.

Rail-to-Rail is a registered trademark of Nippon Motorola, Ltd.

Packaging Mechanical: 8-pin TSSOP (L)

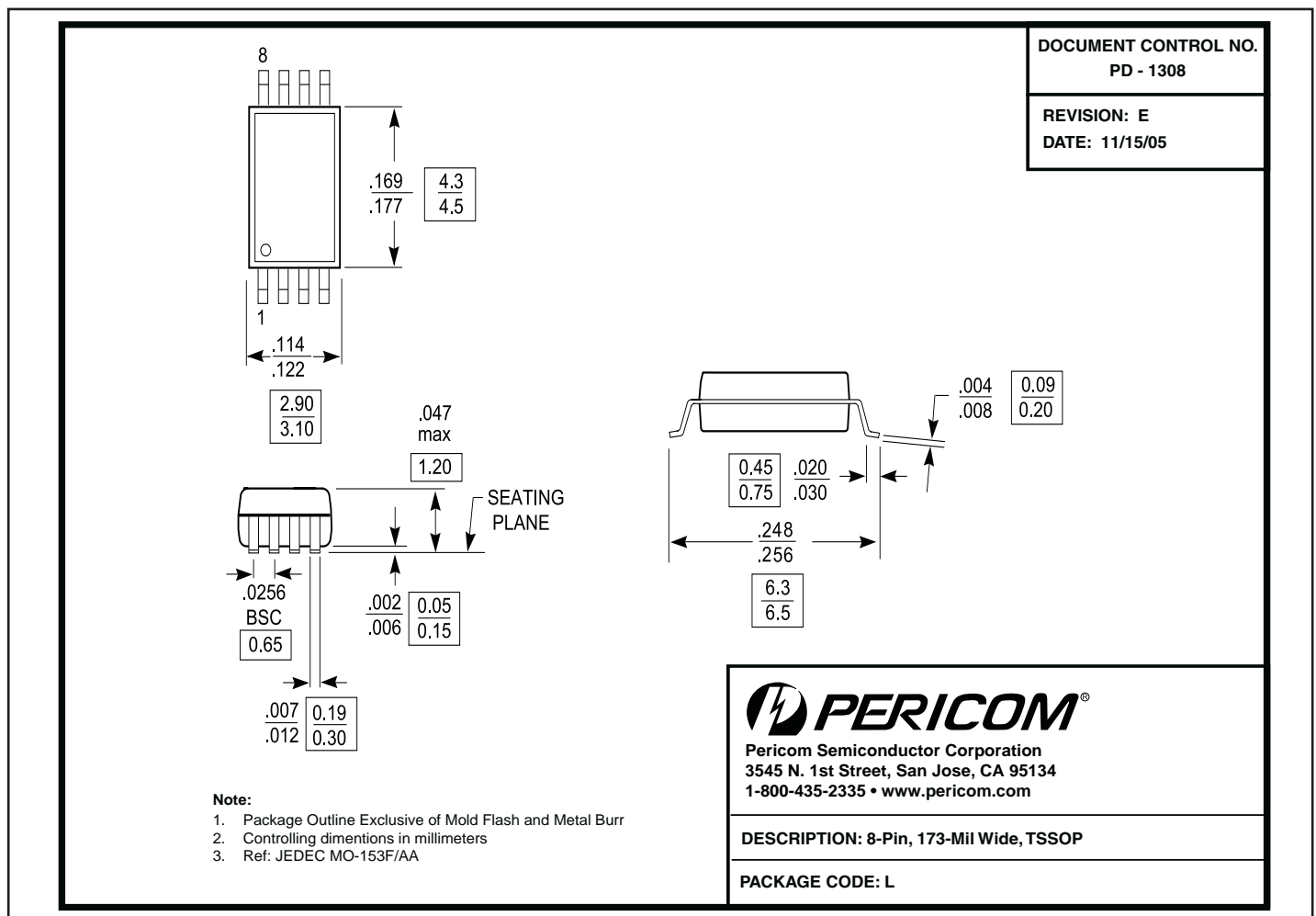

Ordering Information

Ordering Code	Packaging Code	Package Description
PI3CH3306LE	L	Pb-free & Green, 173-mil, 8-pin TSSOP

Notes:

- Thermal characteristics can be found on the company web site at www.pericom.com/packaging/
- E = Pb-free & Green
- Adding an X suffix = Tape/Reel