



CV210-1

Cellular-band Dual-Branch Downconverter

The Communications Edge™

Preliminary Information

Product Features

- High dynamic range downconverter with integrated LO driver and IF amplifiers
- Dual channels for diversity
- +27 dBm Input IP3
- +12 dBm Input P1dB
- 11.5 dB Noise Figure
- RF: 806 - 915 MHz
- IF: 70 - 120 MHz
- Low-side LO downconverter
- Single supply operation (+5 V)
- 6 x 6 mm QFN SMT package

CV Actual Size

Product Description

The CV210-1 is a dual-channel high-linearity downconverter designed to meet the performance, functionality, and cost goals of current and next generation mobile infrastructure basestations.

It is ideally suited for high dynamic range receiver front ends using diversity receive channels. The module is implemented in reliable GaAs MESFET technology and requires only a small 6x6 mm footprint.

Typical applications include frequency downconversion used in CDMA/GSM/TDMA, CDMA2000, W-CDMA, and EDGE 2.5G and 3G mobile base transceiver stations.

Functional Diagram

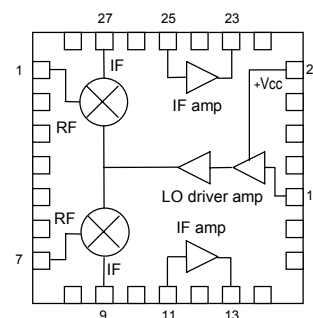

Top View

Specifications¹

Parameters	Units	Minimum	Typical	Maximum	Comments
RF Frequency Range	MHz	806		915	
LO Frequency Range	MHz	730		795	
IF Frequency Range	MHz	70		120	
IF Bandwidth	%		20		
SSB Conversion Gain	dB	8	10	12	
Input IP3	dBm		+27		$\Delta f = 1 \text{ MHz @ } RF_{in} = 0 \text{ dBm / tone}$
Input IP2	dBm		+32		
Input 1 dB Compression Point	dBm		+12		
Noise Figure	dB		11.5	12.5	
LO Input Drive Level	dBm	-2.5	0	+2.5	
LO-RF Isolation	dB		9		$P_{LO} = 0 \text{ dBm}$ $P_{LO} = 0 \text{ dBm}$
LO-IF Isolation	dB		30		
Branch-Branch Isolation	dB		35		
Return Loss: RF Port	dB		14		
Return Loss: LO Port	dB		14		
Return Loss: IF Port	dB		14		
Operating Supply Voltage	V	+4.75	+5	+5.25	
Supply Current	mA		380	460	

¹ Specifications when using application specific circuit with a low side LO = 0 dBm in a downconverting application at 25°C.

Absolute Maximum Rating²

Parameters	Rating
Operating Case Temperature	-40° to +85 °C
Storage Temperature	-65° to +100 °C
Maximum Junction Temperature	+150 °C

² Operation of this device above any of these parameters may cause permanent damage.

Ordering Information

Part No.	Description
CV210-1	Cellular-band Dual-Branch Downconverter

This document contains information on a new product. Specifications and information are subject to change without notice.



CV210-1

Cellular-band Dual-Branch Downconverter

Preliminary Information

Application Circuit

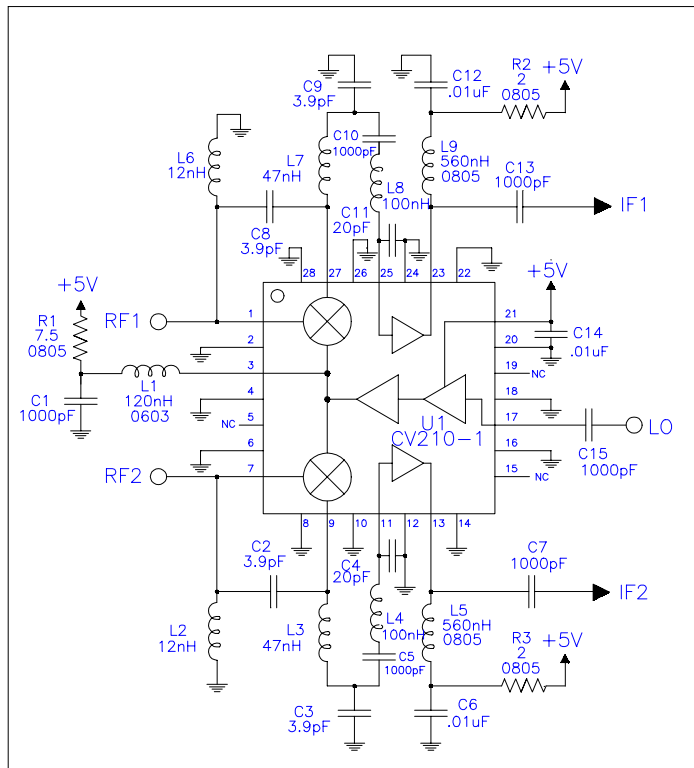

Note:
All components are of size 0603
or 0402 unless otherwise noted.

Assembly Layout

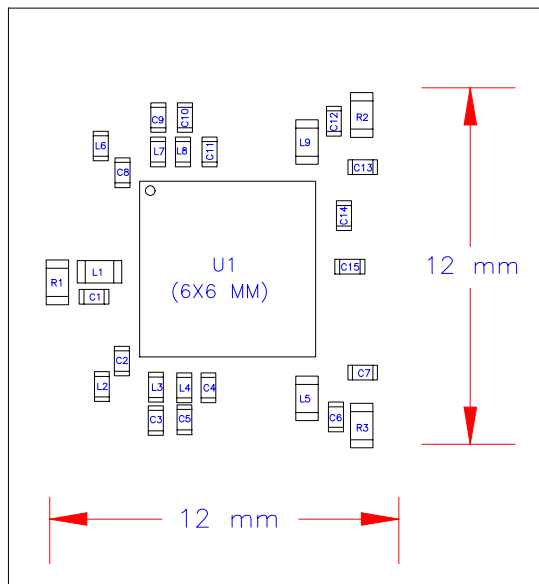

Functional Pin Layout

Pin	FUNCTION	Pin	FUNCTION
1	Channel 1 RF Input	15	N/C
2	GND	16	GND
3	+5 V	17	LO input
4	GND	18	GND
5	N/C	19	N/C
6	GND	20	GND
7	Channel 2 RF Input	21	+5 V
8	GND	22	GND
9	Channel 2 IF Mixer Output	23	Channel 1 IF Amp Output / +5 V
10	GND	24	GND
11	Channel 2 IF Amp Input	25	Channel 1 IF Amp Input
12	GND	26	GND
13	Channel 2 IF Amp Output / +5 V	27	Channel 1 IF Mixer Output
14	GND	28	GND

This document contains information on a new product.
Specifications and information are subject to change without notice.



CV210-1

Cellular-band Dual-Branch Downconverter

Preliminary Information

Outline Drawing

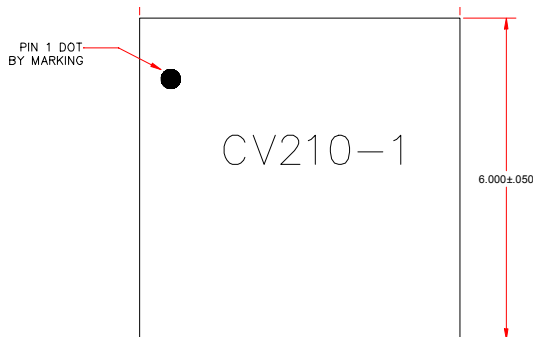

TOP VIEW

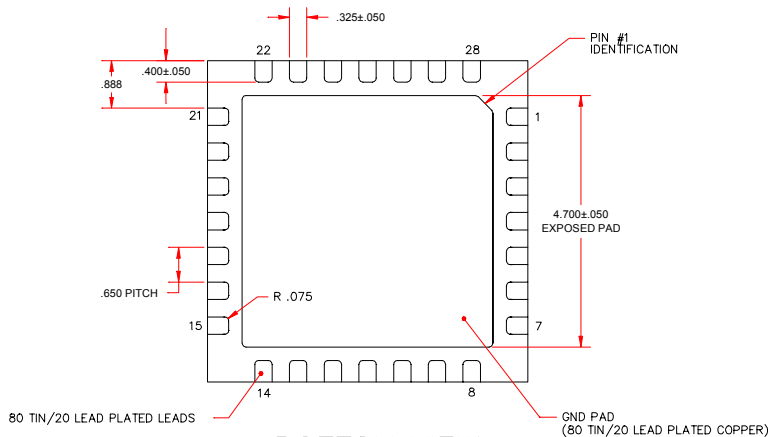

BOTTOM VIEW

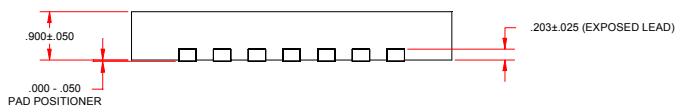

SIDE VIEW

Mounting Configuration

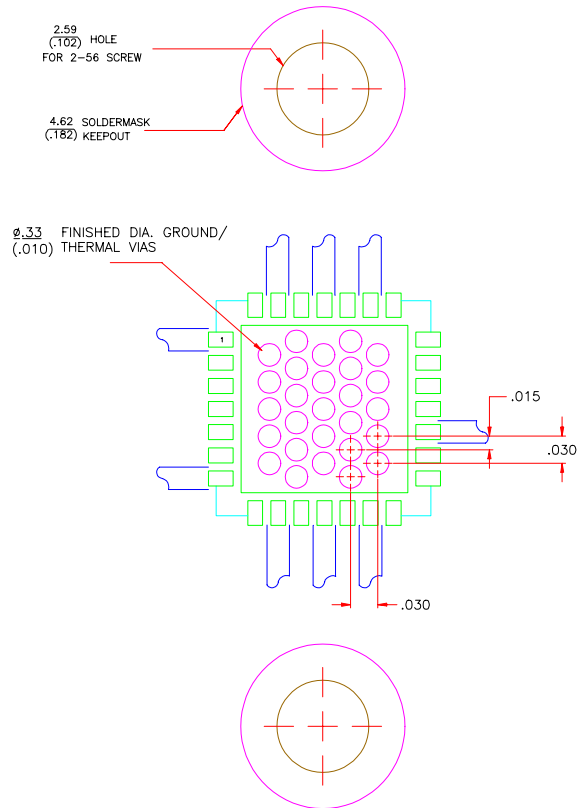

NOTES:

1. THERMAL/GROUND VIAS ARE CRITICAL FOR THE PROPER PERFORMANCE OF THIS PART. VIAS SHOULD USE A .013" DIAMETER DRILL AND HAVE A FINAL, PLATED THRU DIAMETER OF .010".
2. ADD AS MUCH COPPER AS POSSIBLE TO INNER AND OUTER LAYERS NEAR THE PART TO ENSURE OPTIMAL THERMAL PERFORMANCE.
3. ADD MOUNTING SCREWS NEAR THE PART TO FASTEN THE BOARD TO A HEATSINK. ENSURE THAT THE THERMAL/GROUND VIAS CONTACT THE HEATSINK.
4. DO NOT PUT SOLDER MASK ON THE BACK SIDE OF THE PC BOARD IN THE REGIONS WHERE THE BOARD CONTACTS THE HEATSINK.
5. RF TRACE WIDTH DEPENDS UPON THE PC BOARD MATERIAL AND CONSTRUCTION.
6. USE 1 OZ. COPPER MINIMUM.
7. DIMENSIONS ARE IN MILLIMETERS.

This document contains information on a new product. Specifications and information are subject to change without notice.