

TUA 4300 G

Table of Contents

ONE CHIP CAR RADIO

Differences to the last edition	Page	1
Table of Contents	Page	2
Functional Description, Application	Page	3 ... 4
Circuit Description	Page	5 ... 6
Block Diagram	Page	7 ... 10
Pin Assignment	Page	11
Pin Description	Page	12 ...13
Package Outline	Page	14
Absolute Maximum Ratings	Page	15
Operational Range	Page	16
AC / DC Characteristics	Page	17 ... 30
Test Circuit	Page	31 ... 32
Application Circuit	Page	33 ... 34
Diagrams	Page	35 ... 38
Appendix	Page	39

This specification replaces the previous editions

DOK-Nr.	date	DOK-Nr.	date

The reproduction, transmission or use of this document or its contents is not permitted without express written authority. Offenders will be liable for damages. All rights, including rights created by patent grant or registration of a utility model or design, are reserved.

TUA 4300 G

Functional Description, Application**General Description**

The TUA 4300 G is a one chip car radio system consisting of AM/FM receiver, AM-Up/Down conversion, AGC amplifier / demodulator, FM-IF limiter amplifier / demodulator and stereodecoder / noiseblanker.

1. AM/FM-Receiver

The TUA 4300 G is an integrated combined AM-FM-receiver with strictly symmetrical RF parts for use in car radios.

Features

- High flexibility with an external preamplifier stage for AM and FM
- Strictly symmetrical RF parts
- Separate mixers for AM and FM mode
- Sym. or asym. mixer inputs
- Only one 2-pin-oscillator for the 1st LO (in AM mode the oscillator frequency is divided by 8 or 10)
- 1st LO with LC-tank circuit
- 1st LO at 100 MHz range
- 1st LO decoupled counter output
- 1st LO decoupled divided counter output
- Low phase noise
- FM/AM field strength output combined

2. FM Mode**A. FM-Receiver**

In this mode, the receiverpart is comprised of a mixer, an oscillator, a prestage control and an IF post amplification.

Features

- Integrated AGC generation for PIN Diodes and MOSFETs
- High level mixer input
- High input/output 3.order interceptpoint

B. FM-IF Demodulator

The FM-IF-demodulator has been developed especially for car radio applications.

Features

- 7stage limiter amplifier
- Coincidence demodulator
- Field strength output (combined with AM)
- Fixed mute depth (with full muting typ 80dB)
- Multipath detector with analog output

TUA 4300 G

Functional Description, Application**3. Stereodecoder**

This part provides the stereo decoder function and noise blanking for FM car radio applications.

Features

- Internal reference voltage source
- Adjustment free oscillator with ceramic resonator 456 kHz
- Pilot dependent mono/stereo switching with hysteresis
- Stereo indicator output
- Analog mono/stereo blend control (stereo noise control, SNC)
- Pilot canceller (19 kHz)
- Adjacent channel noise suppression (114 kHz)
- Mute facility
- Analog deemphasis control (high cut control, HCC)
- Interference noise detector with integrated high-pass filter (IF level signal or MPX input)
- MPX-input low-pass filter
- Noise blanking at MPX -demodulator outputs.
- L, R audio is common to AM.

4. AM Mode

In this mode, the IC is comprised of a mixer, an oscillator with a divider by 8 or 10, a prestage control, an IF post amplification, 2nd mixer with AGC to convert the 1st IF to the 2nd IF, 2nd local oscillator (buffer for external source), automatic gain controlled amplifier and quasisynchronous demodulator.

The same oscillator is used in AM and FM mode.

Features

- 2nd mixer with AGC
- 1st IF amp; use of CER filter or crystal filter possible
- 2nd LO with quartz or external source
- Output for AM IF counter
- Wide range 2nd IF AGC amplifier
- Quasi synchronous demodulator for AM mode
- Fast AM search tuning stop feature
- HCC for AM

TUA 4300 G

Circuit Description

1. AM/FM-Receiver

The AM/FM-receiver part includes a 2-pin varactor tuned oscillator. In the FM mode the direct oscillator frequency is fed into the double balanced FM mixer, in the AM mode the divided by 8 or 10 oscillator frequency is fed into the AM mixer.

The two separate symmetrical input stages of the IC, one optimized for FM-, the other for AM- mode allow symmetrical and unsymmetrical prestage configuration.

The AM and FM input frequencies are converted to a fix 1st IF in the 10.7 MHz range. The IF is post amplified in separate IF amplifiers, one optimized for FM, the other for AM. Using of a CER filter or crystal filter is possible.

The TUA 4300 G has been designed to work with a PLL in the 100MHz range in both modes or in the AM- mode with the divided frequency.

Depending on the input signal strength, the integrated AGC stage for prestage control drives PIN-Diodes as well as MOSFETs.

2. FM-MODE**A. FM-IF Demodulator**

The FM-IF amplifier includes a 7 stage capacitive coupled limiter amplifier with coincidence demodulator and AF output. The AF output signal can be continuously attenuated to decrease the noise.

There is a field strength output (with min. 76 dB dynamic range, typ. ± 1 dB nonlinearity and typ. ± 3 dB temperature drift) and a fixed muting (with full muting typ 80 dB).

A multipath detector with analog output is available. Its input signal is fed from the high pass filter of the stereo-decoder/noiseblanker and a second 80 kHz 1-pole high pass filter.

3. StereodecoderPower supply, reference current:

A temperature-stable, low noise reference voltage generator is used for better ripple rejection and to generate a reference current. This current is used as a time base for the deemphasis, the gate time of the pulse former, and the pilot cancellation, avoiding temperature and tolerance effects .

MPX input, MPX filter:

A 4-pole low-pass filter determines the bandwidth of the MPX signal.

Voltage Controlled Oscillator, Phase Detector:

The 456 kHz oscillator and the frequency dividers are used as walsh function generators (suppression of 3rd order harmonics) for:

- 38 kHz for the stereo decoder
- 19 kHz inphase for phase detector and pilot cancellation
- 19 kHz quadrature for the phase detector.

The phase detector locks the on chip 19 kHz signal to the pilot tone in the MPX signal at 90 deg phase.

Pilot Detector, Pilot Indicator, Pilot Cancellation:

The voltage at the pilot detector output is proportional to the pilot tone input level. If that level is high enough, the pilot indicator output is activated and the pilot cancellation turned on: a 19 kHz signal proportional to the voltage at the pilot detector output is added to the MPX signal with inverse polarity, cancelling the 19 kHz pilot tone.

Interference Detector, Noise Detector, Pulse Former:

The signal from the interference input (MPX or field strength signal) passes a 4-pole high-pass filter to the noise blanking circuitry. The average noise level is stored in an external capacitor. The interference detector compares the actual noise level with that stored in the capacitor and triggers the pulse former if there is a significant difference. The pulse former generates a gate pulse for the HCC block. During that pulse time the outputs of the deemphasis circuit are switched to hold mode.

TUA 4300 G

Circuit Description**3. AM - MODE**

In the AM mode the 1st IF is converted by the 2nd mixer into the 2nd IF in the 450 kHz range. Therefore a 2nd LO, which is used with quartz or as input for external sources, is part of the IC. An AGC in this mixer increases sensitivity. The 2nd IF signal passes an automatic gain controlled IF amplifier and is then demodulated to the AF in a quasisynchronous demodulator. Switching to seek mode, the AGC time constant is reduced by a factor of 5, the 2nd mixer AGC is forced to high gain, the AM IF counter output is switched on and the AF is muted. The AGC voltage is used as AM field strength and is fed to the combined field strength output.

Block Diagram

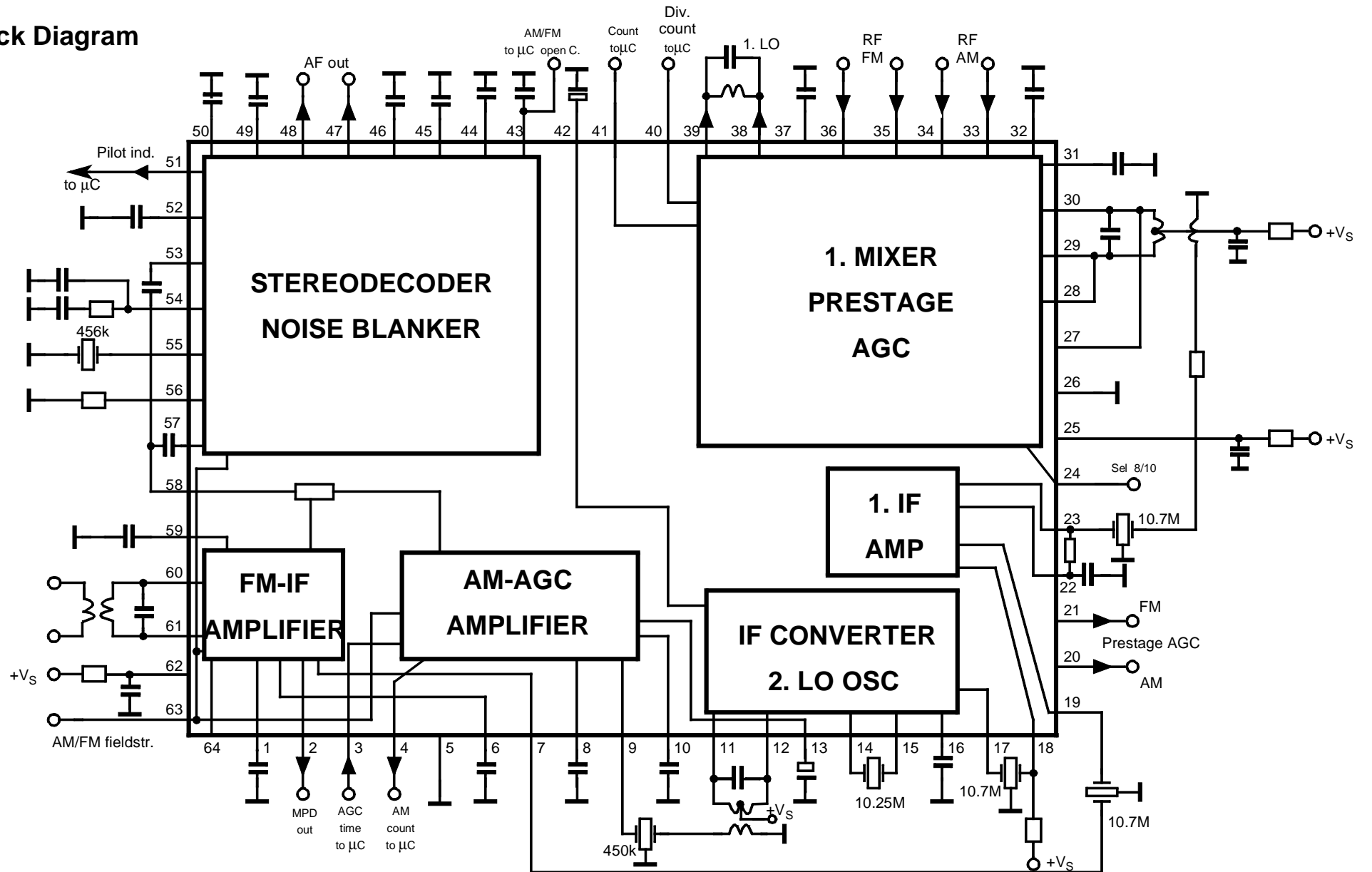

Block Diagram AM/FM Receiver

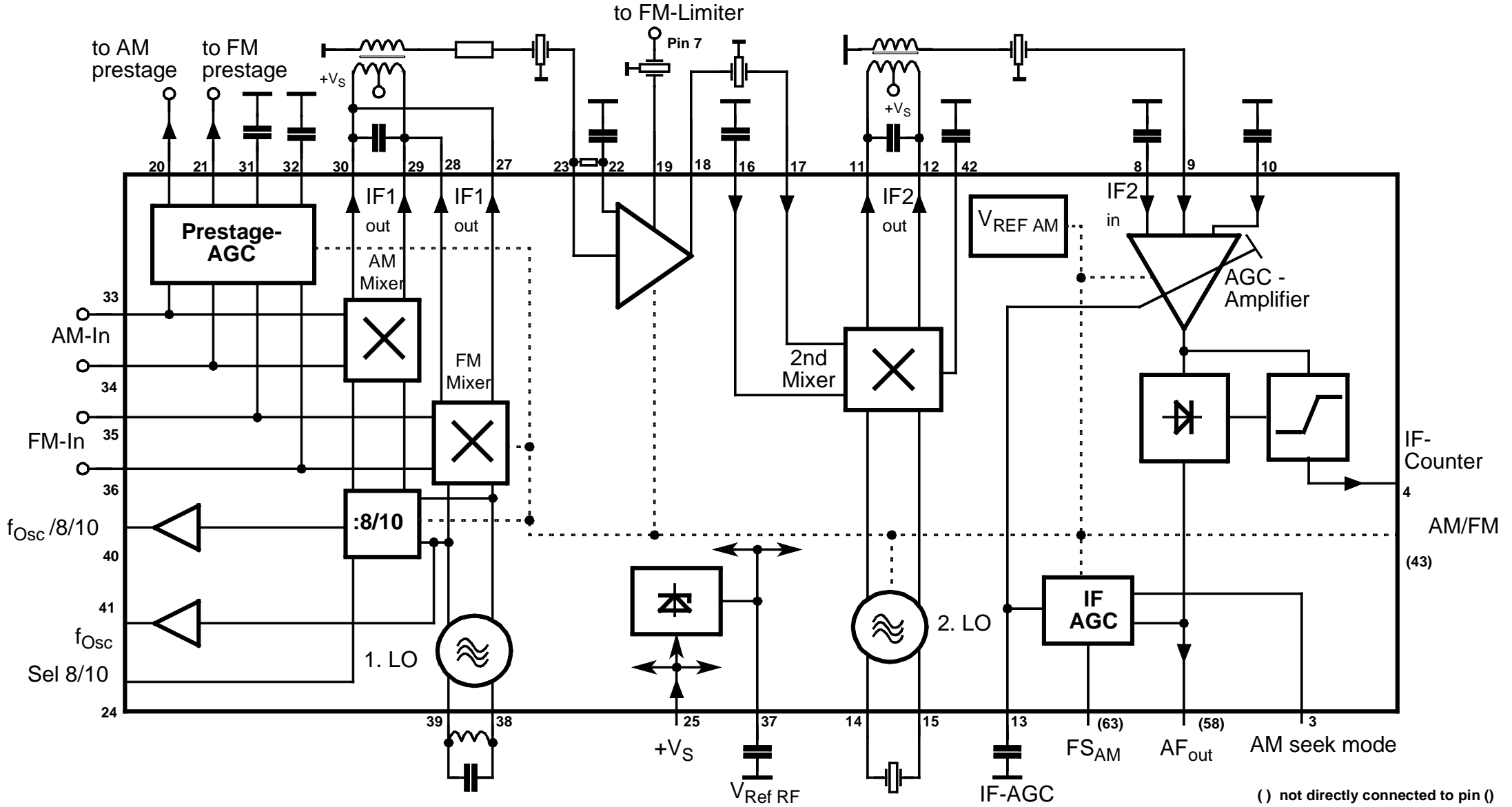

The reproduction, transmission or use of this document or its contents is not permitted without express written authority. Offenders will be liable for damages. All rights, including rights created by patent grant or registration of a utility model or design, are reserved.

Block Diagram FM-IF Amplifier

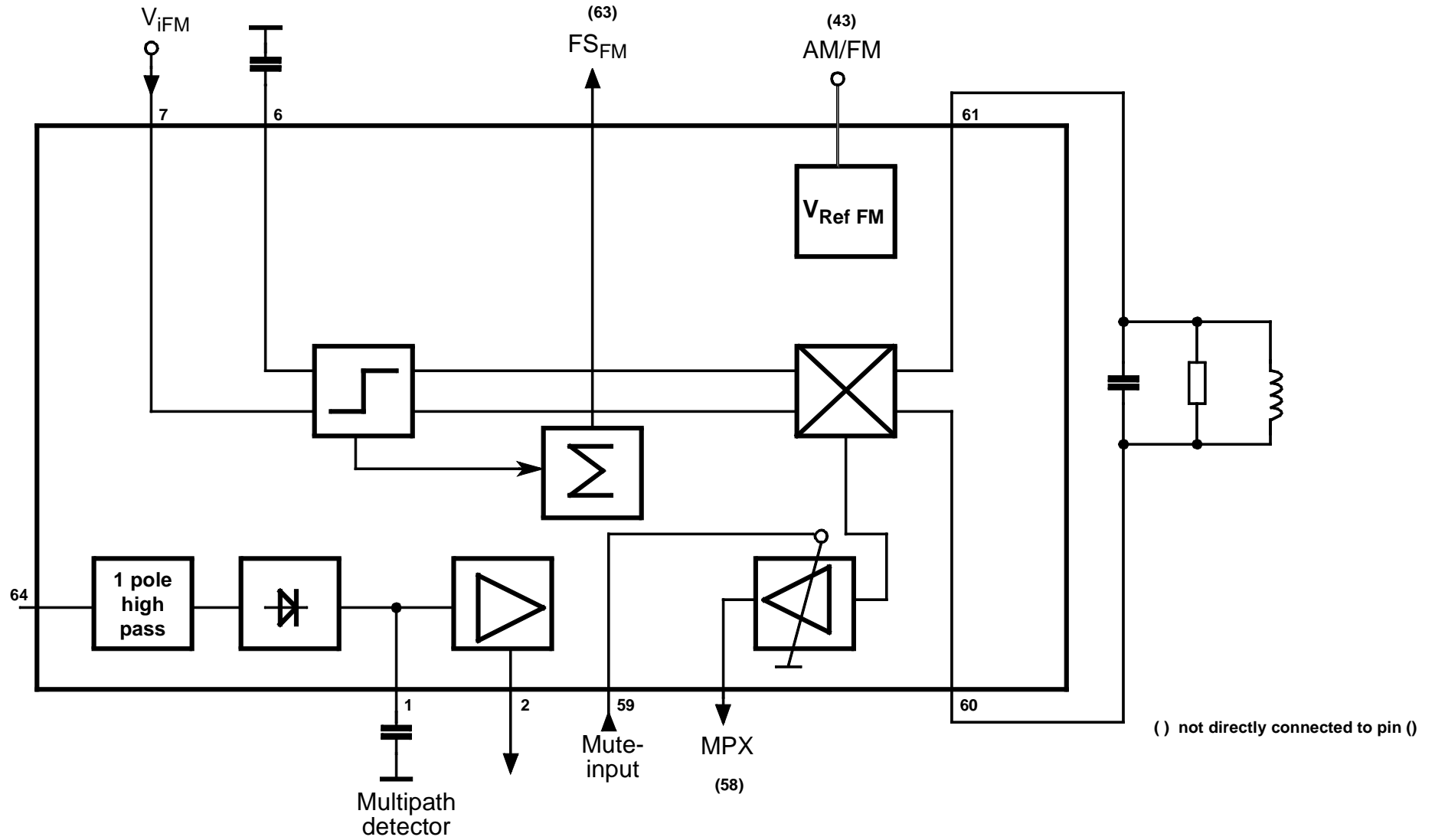

Block Diagram Stereodecoder/Noiseblanker

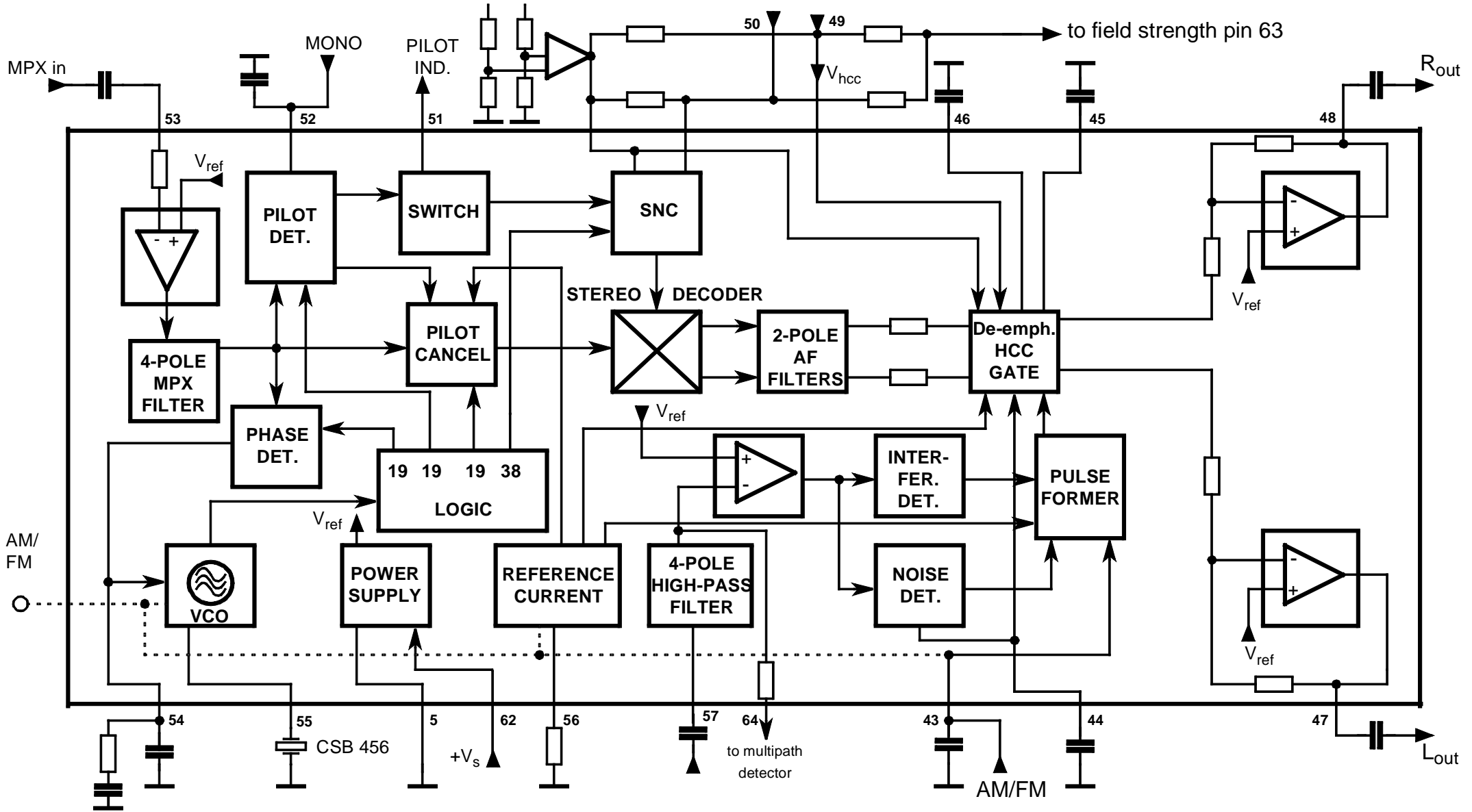

The reproduction, transmission or use of this document or its contents is not permitted without express written authority. Offenders will be liable for damages. All rights, including rights created by patent grant or registration of a utility model or design, are reserved.

TUA 4300 G

Pin Assignment

- 1 Multipath det. cap.
- 2 Multipath det. output
- 3 AM seek mode switch
- 4 AM-IF-counter out
- 5 GND_{IF}
- 6 FM-IF input
- 7 FM-IF input
- 8 AM-IF bias
- 9 AM-IF input
- 10 AM-IF bias
- 11 2nd mixer out
- 12 2nd mixer out
- 13 AM IF AGC cap.
- 14 2nd LO quartz
- 15 2nd LO quartz
- 16 2nd mixer input
- 17 2nd mixer input
- 18 IF amp out AM
- 19 IF amp out FM
- 20 $V_{Prestage}$ AGC AM
- 21 $I_{Prestage}$ AGC FM
- 22 IF amp input bias
- 23 AM IF amp input
- 24 SEL 8 / 10
- 25 $+V_{S RF}$
- 26 GND_{RF}
- 27 FM mixer output
- 28 FM mixer output
- 29 AM mixer output
- 30 AM mixer output
- 31 Prestage AGC cap. AM
- 32 Prestage AGC cap. FM
- 33 RF input AM
- 34 RF input AM
- 35 RF input FM
- 36 RF input FM
- 37 $V_{REF RF}$
- 38 RF oscillator
- 39 RF oscillator
- 40 Divided counter out
- 41 Direct counter out
- 42 2nd mixer AGC cap.
- 43 Noise gate cap./AM-FM
- 44 Noise level cap.
- 45 Deemphasis right
- 46 Deemphasis left
- 47 AF output left
- 48 AF output right
- 49 Control voltage HCC

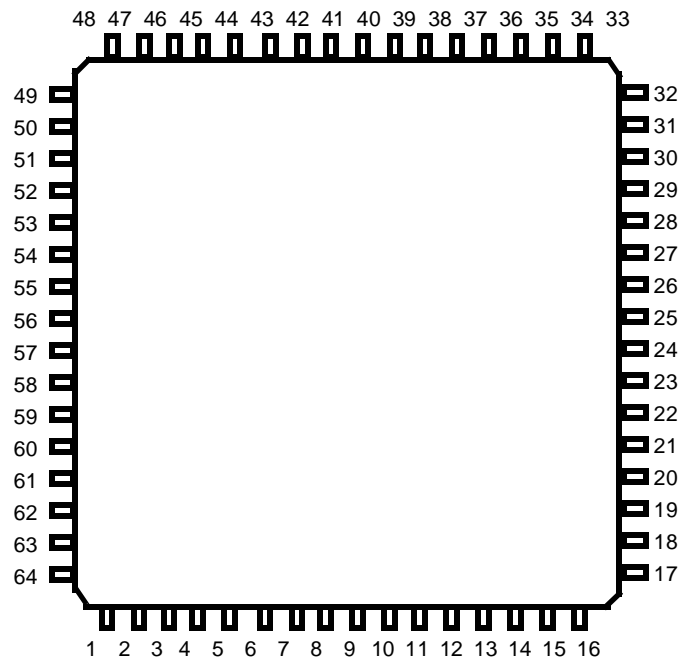

- 50 Control voltage SNC
- 51 Pilot indicator output
- 52 Pilot detector cap.
- 53 MPX-signal input
- 54 Stereo PLL
- 55 Stereo oscillator
- 56 $I_{ref stereo}$
- 57 Noise detector input
- 58 MPX-signal output
- 59 Mute FM
- 60 Demodulator circuit FM
- 61 Demodulator circuit FM
- 62 $+V_{S IF}$
- 63 Fieldstrength output
- 64 Multipath det. input

TUA 4300 G**Pin Description**

- 1) Multipath detector rectifier capacitor
- 2) Analog multipath detector output
- 3) AM seek mode switch; AM IF counter on, 2nd mixer gain high, AM-AGC fast and AM AF mute
- 4) AM-IF counter output for search tuning
- 5) Ground IF and stereodecoder section
- 6) FM limiter input bias decoupling capacitor
- 7) FM limiter input
- 8) AM AGC amplifier bias decoupling capacitor
- 9) AM AGC amplifier input
- 10) AM AGC amplifier bias decoupling capacitor
- 11) 2nd AM mixer outputs (open collector)
- 12) 2nd AM mixer outputs (open collector)
- 13) AM AGC amplifier time constant capacitor
- 14) Oscillator input for 2nd AM mixer
- 15) Oscillator input for 2nd AM mixer
- 16) 2nd AM mixer bias decoupling capacitor
- 17) 2nd AM mixer input
- 18) 10.7 MHz IF amplifier output AM (open collector)
- 19) 10.7 MHz IF amplifier output FM
- 20) AM prestage AGC buffered voltage output with fast attack, slow decay feature
- 21) FM prestage AGC current output for PIN diode
- 22) 10.7 MHz IF amplifier operation point
- 23) 10.7 MHz IF amplifier input AM
- 24) AM 1st local oscillator divider control for dividing by 10 for long wave and medium wave receiving or dividing by 8 for short wave receiving
- 25) Supply voltage RF section
- 26) Ground RF section
- 27) FM mixer outputs (open collector)
- 28) FM mixer outputs (open collector)
- 29) AM mixer outputs (open collector)
- 30) AM mixer outputs (open collector)
- 31) AM prestage AGC time constant capacitor
- 32) FM prestage AGC time constant capacitor; output for MOS FET Gate 2
- 33) AM 1st mixer symmetrical inputs

TUA 4300 G

Pin Description

-
- 34) AM 1st mixer symmetrical inputs
 - 35) FM 1st mixer symmetrical inputs
 - 36) FM 1st mixer symmetrical inputs
 - 37) Reference voltage RF section (4.8 V)
 - 38) 1st local AM/FM oscillator circuit
 - 39) 1st local AM/FM oscillator circuit
 - 40) 1st local oscillator divided by 8/10 counter output (disabled in FM mode)
 - 41) 1st local oscillator counter output
 - 42) 2nd AM mixer AGC time constant capacitor
 - 43) Timing capacitor for Noisedetector monoflop (gate time)
AM/FM mode control; low voltage activates AM section
and disables stereodecoder VCO, Phase detector, Pilot detector, SNC and FM section
 - 44) Hold capacitor for Noise detector average level
low voltage applied mutes the stereo decoder outputs
 - 45) HCC timing / hold capacitor, deemphasis right
 - 46) HCC timing / hold capacitor, deemphasis left
 - 47) AF output left
 - 48) AF output right
 - 49) Control voltage HCC (high cut control)
 - 50) Control voltage SNC (stereo noise control)
 - 51) Pilot indicator output, active high (open collector)
 - 52) Pilot detector capacitor, low voltage activates mono state
 - 53) Stereo decoder MPX signal input
 - 54) Stereo decoder PLL phasedetector, loop filter
 - 55) VCO pin for ceramic resonator
 - 56) Reference current pin, external reference resistor
 - 57) Noise detector input
 - 58) FM MPX signal and AM demodulator signal output
 - 59) Dynamic FM mute control blocking capacitor
 - 60) Demodulator circuit FM
 - 61) Demodulator circuit FM
 - 62) Supply voltage IF and stereodecoder section
 - 63) AM/FM fieldstrength combined output
 - 64) Auxiliary multipath detector input (in parallel to internal connection)

Package Outline

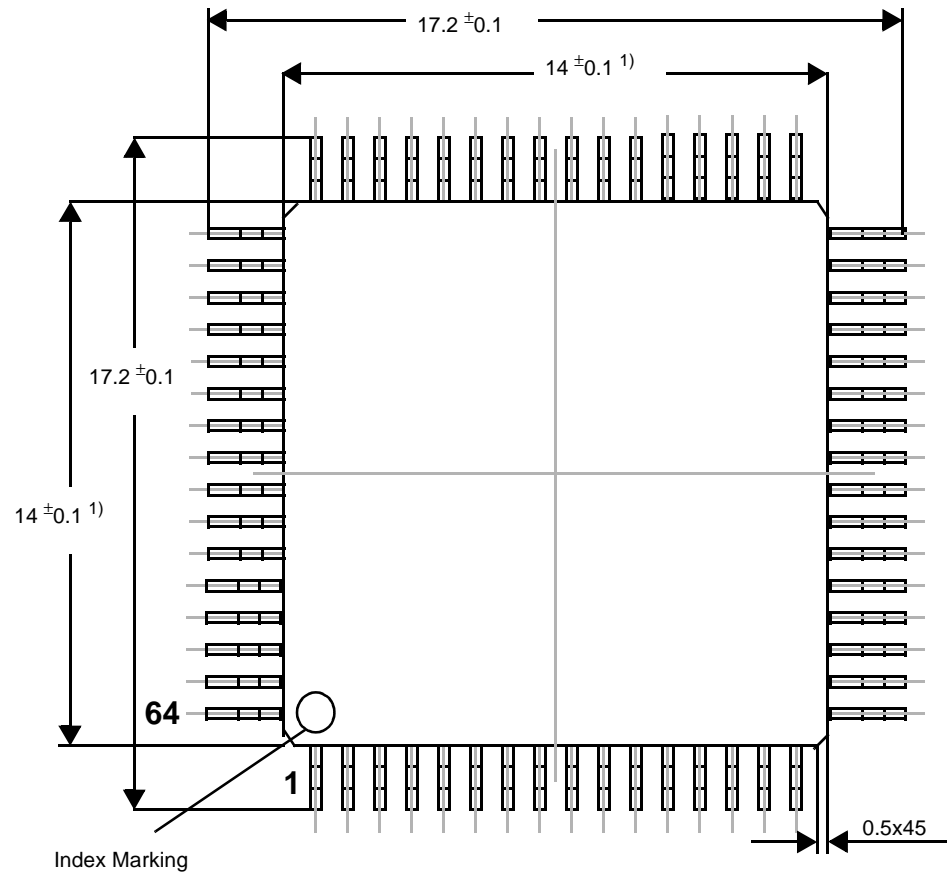

Plastic-Package
P-MQFP-64

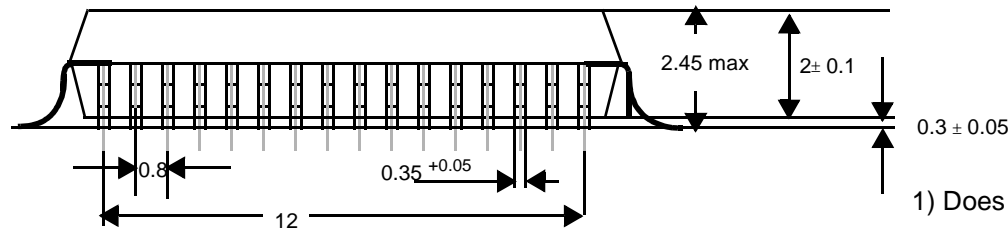
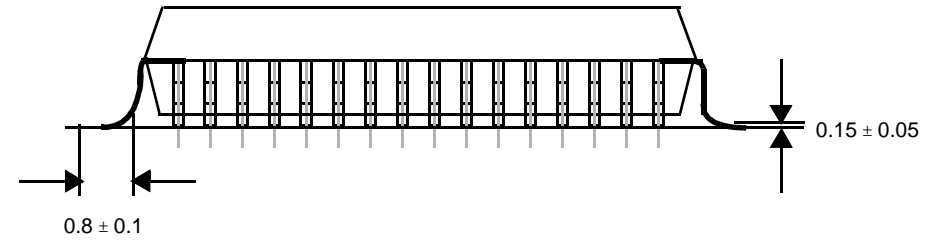

1) Does not include plastic or metal protrusions of 0.25max per side

TUA 4300 G

Absolute Maximum Ratings

The maximal ratings may not be exceeded under any circumstances, not even momentarily and individually, as permanent damage to the IC will result.

#	Max. Ratings for ambient temperature T_{amb} -40 °C to 85 °C	Symbol	Min	Max	Units	Remarks
1	Junction temperature	T_J	-40	150	°C	
2	Storage temperature	T_S	-40	125	°C	
3	Thermal resistance	R_{thSA}		54	K/W	
4	ESD-voltage, HBM	V_{ESD}	-4	+4	kV *)	100pF, 1500 Ω

*) 4 kV ESD protection is not valid for pin 14, 15 and 37.

TUA 4300 G

Operational Range

Within the operational range the IC operates as described in the circuit description. The AC / DC characteristic limits are not guaranteed.

#	Parameter	Symbol	Min	Max	Units	Remarks
1	Supply voltage	V_S	8	9	V	
2	Ambient temperature	T_A	-40	85	°C	

TUA 4300 G

AC / DC Characteristics

AC / DC characteristics involve the spread of values guaranteed within the specified supply voltage and ambient temperature range. Typical characteristics are the median of the production.

#	Parameter	Symbol	Test Conditions	Test Circuit	Min	Typ	Max	Units
Supply voltage $V_S=8.5\text{ V}$								
Ambient temperature $T_{amb}=25\text{ °C}$								
1	Current consumption	I_{SFM}	FM mode	1	80	100	120	mA
		I_{SAM}	AM mode	1	76	95	114	mA
1.AM/FM-Receiver								
1st LO								
1	Frequency range	$f_{1st\ LO}$		1	80		140	MHz
2	Frequency range	$f_{1st\ LO}$	$Q_{factor\ of\ coil} >90$	Lab	50		150	MHz
3	Counter output	V_{41}	$R_{L41}=330\Omega$	1	100	130		mV_{rms}
4	Divided counter output	V_{40}	$R_{L40}=330\Omega$	1	100	130		mV_{rms}
5	Output impedance	R_{40}		Lab	0.8	1	1.2	$k\Omega$
6	Output impedance	R_{41}		Lab	240	300	360	Ω
7	Frequency	$f_{1st\ LO}$	$V_{tuning}=0V$		tbF			MHz
10.7 MHz IF amplifier								
8	DC input voltage	V_{23}	$f_{IF1}=10.7\text{ MHz}$	1	4.4	4.7	5.0	V
9	Input resistance	R_{23}	AM/FM	1	1.5	1.8	2.2	$k\Omega$
10	Output resistance	R_{18}	open Collector	1	100			$k\Omega$
11	Output resistance	R_{19}		1	265	330	396	Ω
12	Voltage gain	A_{23-19}	FM, $R_{19}=330\Omega$	Lab	24	27	30	dB
13	Voltage gain	A_{23-18}	AM, $R_{18}=165\Omega$	Lab	8	11	14	dB
14	Noise figure	F_{AM}	$R_G=330\Omega$	Lab		6		dB
15	Noise figure	F_{FM}	$R_G=330\Omega$	Lab		7		dB
16	Reference voltage	V_{37}		1	4.5	4.8	5.1	V
17	Output Current	I_{37}		1			1	mA
AM mode								
$f_{IF1}=10.7\text{ MHz}$								
$f_{IF2}=450\text{ kHz}$								
$f_{33-34}=1\text{ MHz}$								
$V_{43}=1V$								
Mixer 1								
1	Interceptpoint 3rd order	I_{P3}	Special testcircuit necessary	Lab		134		$dB\mu V$
2	Mixer gain	A_{M1}	$V_{33,34}=80mV_{rms}; V_{out}=V_{23}$ ($X_F=1k5//5p; a_F=-2dB$)	Lab		-2		dB
3	Over all gain	$A_{M\ IF}$	$V_{33,34}=80mV_{rms}; V_{out}=V_{IF10.7}$	1	1	5	9	dB
4	Max. input voltage	V_{33-34}	SINAD > 34dB; m=80%	1	1100	1400		mV_{pp}
5	Noise figure (10 MHz)	F	$R_{g\ opt}=700\Omega$	Lab		7		dB
6	Input impedance	R_{33-34}	sym.	Lab	3.2	4	4.8	$k\Omega$
7	Input impedance	C_{33-34}	sym.	Lab	1.6	2	2.4	pF
8	Input impedance	R_{33-34}	asym.	Lab	1.6	2	2.4	$k\Omega$
9	Input impedance	C_{33-34}	asym.	Lab	3.2	4	4.8	pF
10	1st LO divided by 8	V_{24Low}		1	0		0.7	V
11	1st LO divided by 10	V_{24High}	or open	1	2.4		5	V

TUA 4300 G

AC / DC Characteristics

AC / DC characteristics involve the spread of values guaranteed within the specified supply voltage and ambient temperature range. Typical characteristics are the median of the production.

#	Parameter	Symbol	Test Conditions	Test Circuit	Min	Typ	Max	Units
Prestage AGC output								
10	AGC-voltage AM	V_{20}	$V_{33,34} = 50\text{mV}_{\text{rms}}$	1	6	7		V
11	AGC-voltage AM	V_{20}	$V_{33,34} = 200\text{mV}_{\text{rms}}$	1	0		0.5	V
12	AGC-voltage FM	V_{32}	$V_{33,34} = 50\text{mV}_{\text{rms}}$	1	0		0.15	V
13	AGC-current FM	I_{21}	$V_{33,34} = 50\text{mV}_{\text{rms}}$	1	0		0.1	mA
14	Integrator Current	I_{31}^*	$V_{33,34} = 50\text{mV}_{\text{rms}}$ $V_m = 3\text{V}$	1	-30	-38	-49	μA
15	Integrator Current	I_{31}^*	$V_{33,34} = 200\text{mV}_{\text{rms}}$ $V_m = 3\text{V}$	1	+32	+40	+51	μA
2nd AM IF section								
Mixer 2								
1	Max. Mixer gain	A_{M2}	$V_{17} = 1\text{mV}$; $V_{\text{out}} = V_{IF450}$ $f_{17} = 10.7\text{ MHz}$; $f_{14} = 10.25\text{ MHz}$	1	17	20	23	dB
2	Mixer AGC-range	ΔA	$\Delta A = A_{V17=1\text{mV}} - A_{V17=100\text{mV}}$	1	17	20	23	dB
3	Mixer gain seek mode on		$V_{17} = 1\text{mV}$; $V_3 = 0.7\text{V}$	1	17	20	23	dB
4	Noise figure	F		Lab		10		dB
5	Integrator Current	I_{42}^*	$V_{17} = 0$ $V_m = 3\text{V}$	1	+80	+150	+230	μA
6	Integrator Current	I_{42}^*	$V_{17} = 100\text{mV}_{\text{rms}}$ $V_m = 3\text{V}$	1	-190	-270	-380	μA
2nd LO								
7	Operational frequency f_{14}			1	9.25	10.25	11.25	MHz
8	External force voltage	V_{14}	$R_g = 600\Omega$; $C_k = 100\text{pF}$	1	30			mV_{rms}
9	Input Imp. Crystal Osc.	Z_{14}		Lab	-500	-600	-400	Ω
10	Crystal Resistance	R_{C1}	$P_{\text{TOTC}} = 50\mu\text{W}$; Fundamental				100	Ω
11	Spurious Harm. Cryst.	a_{SP}	$P_{\text{TOTC}} = 50\mu\text{W}$; $F < 30\text{ MHz}$		-20			dB
FM mode								
$f_{IF} = 10.7\text{ MHz}$								
$f_{35-36} = 100\text{ MHz}$								
$V_{43} = \text{open}$								
Mixer 1								
1	Interceptpoint 3rd order	I_{P3}	special testcircuit necessary	Lab		125		dB μV
2	Noise figure (10 MHz)	F	$R_{g\text{ opt}} = 500\Omega$	Lab		6		dB
3	Mixer gain	A_{M1}	$V_{35-36} = 10\text{mV}_{\text{rms}}$; $V_{\text{out}} = V_{23}$ ($R_F = 330\Omega$; $a_F = -4\text{dB}$)	Lab		9		dB
4	Over all gain	$A_{M\text{ IF}}$	$V_{35,36} = 10\text{mV}_{\text{rms}}$; $V_{\text{out}} = V_{IF10.7}$	1	26	32	38	dB
5	Input impedance	R_{35-36}	sym.	Lab	3.2	4	4.8	$\text{k}\Omega$
6	Input impedance	C_{35-36}	sym.	Lab	1.6	2	2.4	pF
7	Input impedance	R_{35-36}	asym.	Lab	1.6	2	2.4	$\text{k}\Omega$
8	Input impedance	C_{35-36}	asym.	Lab	3.2	4	4.8	pF
Prestage AGC output								
9	AGC voltage FM	V_{32}	$V_{35,36} = 0\text{mV}_{\text{rms}}$	1	5.6	6.4	7.2	V
10	AGC voltage FM	V_{32}	$V_{35,36} = 50\text{mV}_{\text{rms}}$	1	0		0.1	V
11	AGC current FM	I_{21}	$V_{35,36} = 0\text{mV}_{\text{rms}}$	1	9.5	12	14.5	mA
12	AGC current FM	I_{21}	$V_{35,36} = 50\text{mV}_{\text{rms}}$	1	0		0.1	mA
13	AGC voltage AM	V_{28}	$V_{35,36} = 0$	1	0		0.5	V
14	Integrator Current	I_{32}^*	$V_{35} = 0$ $V_m = 4.8\text{V}$	1	-12	-25	-46	μA
15	Integrator Current	I_{32}^*	$V_{35} = 100\text{mV}_{\text{rms}}$ $V_m = 4.8\text{V}$	1	+42	+60	+81	μA

*) Integrator currents are measured between the output pin (- Pole of the measurement equipment) and a voltage source V_m (+ Pole)

TUA 4300 G

AC / DC Characteristics

AC / DC characteristics involve the spread of values guaranteed within the specified supply voltage and ambient temperature range. Typical characteristics are the median of the production.

#	Parameter	Symbol	Test Conditions	Test Circuit	Min	Typ	Max	Units
2.FM Demodulator								
Measuring condition:								
$f_{iIF}=10.7\text{ MHz}; \Delta f=\pm 75\text{ kHz}; f_{mod}=1\text{ kHz}; V_7=10\text{ mV}_{rms}$								
$V_{44}=\text{open}; \text{Deemphasis}=100\ \mu\text{s}$								
1	Field strength output	V_{63}						
	-dynamic range	see Diagram D1		1	66	72		dB
	-nonlinearity	see Diagram D2		1		± 1		dB
	-temperature drift	see Diagram D3		1			± 3	dB
	-load capacitance						50	pF
	-load resistance				1			k Ω
		V_{63}	$V_7=200\text{mV}_{rms}$	1	4	4.6	5.2	V
		V_{63}	$V_7=1\text{mV}_{rms}$	1	1.5	1.9	2.3	V
		V_{63}	$V_7=0\text{mV}_{rms}$	1	0		1	V
2	AF-output voltage	$V_{58\text{ FM}}$	$R_L > 10\text{k}\Omega; \text{Deemph.}=100\ \mu\text{s}$	1	400	500	600	mV_{rms}
3	AF-output voltage	$V_{58\text{ FM}}$	$R_L > 10\text{k}\Omega; \text{no Deemph.}$	Lab		600		mV_{rms}
4	Input voltage for limiter threshold	V_7	$V_{58}=V_{58\text{ FM}} - 3\text{dB}$	1		33	42	μV_{rms}
5	Total harmonic distortion	THD_1		1			1.2	%
6	AM-suppression	a_{AM}	$m=30\%$	1	70	80		dB
7	Signal-to-noise ratio	$a_{S/N}$		1	72	80		dB
8	AF mute	a_{AF}	$V_{59}=0$	1	10	12	14	dB
Multipath detector								
$f_{57}=200\text{ kHz}$								
10	Attack current	$I_1^*)$	$V_{64AC}=1V_{pp}, V_m=5.0\text{ V}$	1	600	800	1000	μA
11	Recovery current	$I_1^*)$	$V_{64AC}=0; V_m=3.6\text{ V}$	1	- 6	- 9	-12	μA
12	Start voltage	V_{2Def}	$V_{57AC}=0\text{V}$	1	4.4	4.7		V
13	Detector characteristic	V_2	$f_{57}=25\text{kHz}; V_{57}=100\text{mV}_{pp}$	1	$V_{2Def}-0.14\text{V}$	$V_{2Def}-0.1\text{V}$	$V_{2Def}-0.07\text{V}$	V
14	Detector characteristic	V_2	$f_{57}=200\text{kHz}; V_{57}=100\text{mV}_{pp}$	1	$V_{2Def}-1.8\text{V}$	$V_{2Def}-1.6\text{V}$	$V_{2Def}-1.4\text{V}$	V

*) Integrator currents are measured between the output pin (- Pole of the measurement equipment) and a voltage source V_m (+ Pole)

TUA 4300 G

AC / DC Characteristics

AC / DC characteristics involve the spread of values guaranteed within the specified supply voltage and ambient temperature range. Typical characteristics are the median of the production.

#	Parameter	Symbol	Test Conditions	Test Circuit	Min	Typ	Max	Units
3.Stereodecoder								
Measuring condition:								
$V_{53}=600mV_{rms}$; $f=1$ kHz; 15kHz LP with 19kHz Notch; see appendix								
1	Total harmonic distortion	THD _{47,48}	$f=1$ kHz	1		0.1	0.3	%
2	Signal to noise ratio	S/N _{47,48}	Stereo	1	65	75		dB
3	Channel separation	a_{Sep}		1	28	40		dB
4	AF output voltage	$V_{47,48}$	Stereo	1	310	390	470	mV_{rms}
5	Overdrive margin	$V_{47,48 max}$	THD= 1%	1	4	8		dB
6	AF output DC voltage	$V_{DC 47,48}$		1	2.5	3	3.5	V
7	Difference of output voltage levels	$\Delta V_{47,48}$		1			2	dB
8	Muting depth	$A_{47,48}$	$V_{44}=0$	1	70	75		dB
9	Muting depth	$A_{47,48}$	$V_{44}=0.7V$	1	70	75		dB
10	DC-offset at mute	$\Delta_{DC 47,48}$		1	-100	0	100	mV
11	DC-offset stereo on/off	$\Delta_{DC 47,48}$		1	-100	0	100	mV

TUA 4300 G

AC / DC Characteristics

AC / DC characteristics involve the spread of values guaranteed within the specified supply voltage and ambient temperature range. Typical characteristics are the median of the production.

#	Parameter	Symbol	Test Conditions	Test Circuit	Min	Typ	Max	Units
---	-----------	--------	-----------------	--------------	-----	-----	-----	-------

Carrier and harmonic suppression (referenced to $V_{47,48}=390 \text{ mV}_{\text{rms}}$)

1	Pilotsignal (f=19kHz) subcarrier	α_{19}		1	40	45		dB
2	(f=38kHz)	α_{38}		1	40	50		dB
3	(f=57kHz)	α_{57}		1	40	50		dB

Mono/Stereo control

Pilot threshold voltage:

1	For stereo"on"	V_{PILon}		1		20	30	mV_{rms}
2	For stereo"off"	V_{PILoff}		1	5	14		mV_{rms}
3	Hysteresis		$V_{\text{PILon}} / V_{\text{PILoff}}$	1		3		dB

Stereo-indicator output

4	Pilot off	$V_{51\text{off}}$	$I_{51}=1\text{mA}$				0.5	V
5	Pilot on	$I_{51\text{on}}$	$V_{51}=8\text{V}$				10	μA

external control voltages (active low)

6	Operational voltage for external mono control (pin 52)	$V_{52\text{thr}}$		1			1	V
7	Operational voltage for AM/FM (pin 43)	$V_{43\text{thr}}$	AM on	1			1	V

Deemphasis

Reference frequency = 400Hz

 $C_{\text{deemph}}=10\text{nF}; \tau_{\text{nom}}=75 \mu\text{s}$

8	Minimum FM	$A_{\text{min FM}}$	$V_{49} \geq 3.8\text{V}; f_m=5\text{kHz}$	1	6.6	7.8	9	dB
9	Maximum FM	$A_{\text{max FM}}$	$V_{49} = 0\text{V}; f_m=5\text{kHz}$	1	13	16	19	dB
10	Minimum AM	$A_{\text{min AM}}$	$V_{49} \geq 4.4\text{V}; f_m=5\text{kHz}$	1	6.6	7.8	9	dB
11	Maximum AM	$A_{\text{max AM}}$	$V_{49} = 0\text{V}; f_m=5\text{kHz}$	1	11.5	14.5	17.5	dB

TUA 4300 G

AC / DC Characteristics

AC / DC characteristics involve the spread of values guaranteed within the specified supply voltage and ambient temperature range. Typical characteristics are the median of the production.

#	Parameter	Symbol	Test Conditions	Test Circuit	Min	Typ	Max	Units
Stereo/Mono blend control :								
1	Channel separation	a_{Sep}	$V_{50}=3.8V$	1	28			dB
2	Channel separation	a_{Sep}	$V_{50}=3.2V$	1			3	dB
Oscillator								
3	Max. Osc. frequency	f_{oscmax}	$100 \% \times (f_{max}/456kHz-1)$	1	0.7	1.0	2.0	%
4	Min. Osc. frequency	f_{oscmin}	$100 \% \times (f_{min}/456kHz-1)$	1	-2.0	-1.0	-0.7	%
5	VCO-gain	$\Delta f/\Delta V_1$		1	-12	-8	-4	kHz/V
6	Oscillator voltage	$V_{55 DC}$		1	2.5	4	5.5	V
7	Oscillator swing	$V_{55 AC}$		1	260	370	470	mV _{rms}
PLL								
8	PD-gain	$\Delta i/\Delta \phi$	$V_{pilot} = 54 \text{ mV}_{rms}$	note 1	6.0	8.2	10.2	$\mu A/rad$
Noise detector								
9	Input resistance	R_{57}		Lab	80	99	120	k Ω
10	Input high-pass filter	f_{in57}	-3dB	Lab	80	100	120	kHz
11	Trigger threshold	$V_{57 min}$	$V_{44} = V_{44} (V_{57 mean}=0) ,$ $f_{57}=200 \text{ kHz}$	1		30	50	mV _{rms}
12	Trigger threshold	$V_{57 dyn}$	$V_{44} = V_{44} (V_{57 mean}=50mV_{rms}) ,$ $f_{57}=200 \text{ kHz}$	1	130	170	210	mV _{rms}
13	Maximum noise mean value *	$V_{57 maxmean}$	$f_{57}=200 \text{ kHz}$	1	65	80	115	mV _{rms}
14	Suppression pulse duration			1	34	40	46	μs
15	Input offset current	$I_{45,46}$		Lab	-50	0	50	nA

*) The trigger threshold is adapted to the input noise. IF max. noise mean value is exceeded, threshold is too high for any trigger of the noise blanker.

TUA 4300 G

AC / DC Characteristics

AC / DC characteristics involve the spread of values guaranteed within the specified supply voltage and ambient temperature range. Typical characteristics are the median of the production.

#	Parameter	Symbol	Test Conditions	Test Circuit	Min	Typ	Max	Units
---	-----------	--------	-----------------	--------------	-----	-----	-----	-------

4.AM Mode**AGC-Amplifier**

Measuring condition:

$f_{iF} = 450 \text{ kHz}$; $f_{mod} = 1 \text{ kHz}$; $V_9 = 10 \text{ mV}_{rms}$, Deemphasis=100 μs

1	AGC-range	ΔA	$V_{58} = V_{58AM} \pm 3 \text{ dB}$	1	70	80		dB
2	Input sensitivity	V_9	$V_{58} = V_{58AM} - 3 \text{ dB}$	1		30		μV_{rms}
3	AGC time seek mode on	V_{3L}		1	0		0.7	V
4	AGC time seek mode off	V_{3H}		1	2.4		5	V
5	Integrator Current	I_{13}^*	$V_9 = 0$; $V_m = 3 \text{ V}$	1	+80	+100	+120	μA
6	Integrator Current	I_{13}^*	$V_9 = 200 \text{ mV}_{rms}$; $V_m = 3 \text{ V}$	1	-80	-100	-120	μA
7	Integrator Current	I_{13}^*	$V_9 = 0$ $V_m = 3 \text{ V}$; $V_3 = 0.7 \text{ V}$	1	+520	+650	+780	μA
8	Integrator Current	I_{13}^*	$V_9 = 200 \text{ mV}_{rms}$; $V_m = 3 \text{ V}$; $V_3 = 0.7 \text{ V}$	1	-520	-650	-780	μA
9	Field strength output	V_{63}	$V_9 = 0 \text{ mV}$; seek mode off	1	0	0.3	0.6	V
10		V_{63}	$V_9 = 100 \mu\text{V}$; seek mode off	1	1.4	1.7	2.1	V
11		V_{63}	$V_9 = 500 \mu\text{V}$; seek mode off	1	2.4	2.7	3.0	V
12		V_{63}	$V_9 = 5 \text{ mV}$; seek mode off	1	3.5	4.1	4.7	V
13		V_{63}	$V_9 = 30 \text{ mV}$; seek mode off	1	4.0	4.6	5.1	V

Demodulator

17	AF output voltage	V_{58AM}	$m = 0.8$	1	360	480	600	mV_{rms}
18	AF output voltage	V_{1AM}	$m = 0.8$; Deemph=100 μs	Lab	305	406	507	mV_{rms}
19	Total harm. distortion	THD_{64}	$m = 0.8$	1		0.7	2	%
20	(S+N)/N		$m = 0.8$; $V_9 = 20 \mu\text{V}$	1		30		dB
	(S+N)/N		$m = 0.8$; $V_9 = 200 \mu\text{V}$	1		50		dB
21	(S+N)/N		$m = 0.8$; $V_9 = 100 \text{ mV}_{rms}$	1		66		dB
22	AF-linearity	ΔV_{58}	$V_9 = 100 \mu\text{V}/50 \text{ mV}$	1			3	dB

IF - Counter

23	IF - counter Output voltage	V_4	$R_L = 100 \text{ k}\Omega$ $V_3 = 0.7 \text{ V}$	1	320	400	480	mV_{rms}
24	IF-counter output voltage	V_4	$V_3 = 2.4 \text{ V}$	1			1	V_{DC}
25	IF-counter Output voltage	V_{4AC}	$V_3 = 2.4 \text{ V}$	1			1	mV_{rms}

*) Integrator currents are measured between the output pin (- Pole of the measurement equipment) and a voltage source V_m (+ Pole)

TUA 4300 G

AC / DC Characteristics

AC / DC characteristics involve the spread of values guaranteed within the specified supply voltage and ambient temperature range. Typical characteristics are the median of the production.

#	Parameter	Symbol	Test Conditions	Test Circuit	Min	Typ	Max	Units
Supply voltage		$V_S=8.5\text{ V}$						
Ambient temperature		$T_{\text{amb}}= -40\text{ to }+85\text{ }^\circ\text{C}$						
1	Current consumption	I_{SFM}	FM mode	1	70	100	130	mA
		I_{SAM}	AM mode	1	66	96	124	mA
1.AM/FM-Receiver								
1st LO								
1	Frequency range	$f_{1\text{st LO}}$		1	80		140	MHz
2	Frequency range	$f_{1\text{st LO}}$	$Q_{\text{factor of coil}} >90$	Lab	50		150	MHz
3	Counter output	V_{41}	$R_{L41}=330\Omega$	1	90	130		mV_{rms}
4	Divided counter output	V_{40}	$R_{L40}=330\Omega$	1	90	130		mV_{rms}
5	Output impedance	R_{40}		Lab	0.7	1	1.3	$\text{k}\Omega$
6	Output impedance	R_{41}		Lab	210	330	390	Ω
7	Frequency	$f_{1\text{st LO}}$	$V_{\text{tuning}}=0\text{V}$ $f_{\text{IF1}}=10.7\text{ MHz}$		tbf			MHz
10.7 MHz IF amplifier								
8	DC input voltage	V_{23}		1	4.3	4.7		V
9	Input resistance	R_{23}	AM/FM	1	1.35	1.8	2.35	$\text{k}\Omega$
10	Output resistance	R_{18}	open Collector	1	100			$\text{k}\Omega$
11	Output resistance	R_{19}		1	230	330	430	Ω
12	Voltage gain	A_{23-19}	FM, $R_{19}=330\Omega$	Lab	22	27	32	dB
13	Voltage gain	A_{23-18}	AM, $R_{18}=330\Omega$	Lab	6	11	16	dB
14	Noise figure	F_{AM}	$R_G=330\Omega$	Lab		6		dB
15	Noise figure	F_{FM}	$R_G=330\Omega$	Lab		7		dB
16	Reference voltage	V_{37}		1	4.4	4.8	5.2	V
17	Output Current	I_{37}		1			1	mA
AM mode								
$f_{\text{IF1}}=10.7\text{ MHz}$								
$f_{\text{IF2}}=450\text{ kHz}$								
$f_{33-34}=1\text{ MHz}$								
$V_{43}=1\text{V}$								
Mixer 1								
1	Interceptpo 3rd order			Lab		134		$\text{dB}\mu\text{V}$
2	Mixer gain	A_{M1}	Special testcircuit necessary $V_{33,34}=80\text{mV}_{\text{rms}}; V_{\text{out}}=V_{23}$ ($X_F=1\text{k}5//5\text{p}; a_F=-2\text{dB}$)	Lab		-2		dB
3	Over all gain	$A_{\text{M IF}}$	$V_{33,34}=80\text{mV}_{\text{rms}}; V_{\text{out}}=V_{\text{IF}10.7}$	1	-1	5	11	dB
4	Max. input voltage	V_{33-34}	$\text{SINAD} > 34\text{dB}; m=80\%$	1	1000	1400		mV_{pp}
5	Noise figure (10 MHz)	F	$R_{g\text{ opt}}=700\Omega$	Lab		7		dB
6	Input impedance	R_{33-34}	sym.	Lab	3.1	4	4.9	$\text{k}\Omega$
7	Input impedance	C_{33-34}	sym.	Lab	1.5	2	2.5	pF
8	Input impedance	R_{33-34}	asym.	Lab	1.5	2	2.5	$\text{k}\Omega$
9	Input impedance	C_{33-34}	asym.	Lab	3.1	4	4.9	pF
10	1st LO divided by 8	$V_{24\text{Low}}$		1	0		0.7	V
11	1st LO divided by 10	$V_{24\text{High}}$	or open	1	2.4		5	V

TUA 4300 G

AC / DC Characteristics

AC / DC characteristics involve the spread of values guaranteed within the specified supply voltage and ambient temperature range. Typical characteristics are the median of the production.

#	Parameter	Symbol	Test Conditions	Test Circuit	Min	Typ	Max	Units
Prestage AGC output								
10	AGC-voltage AM	V_{20}	$V_{33,34} = 50\text{mV}_{\text{rms}}$	1	6	7		V
11	AGC-voltage AM	V_{20}	$V_{33,34} = 200\text{mV}_{\text{rms}}$	1	0		0.7	V
12	AGC-voltage FM	V_{32}	$V_{33,34} = 50\text{mV}_{\text{rms}}$	1	0		0.5	V
13	AGC-current FM	I_{21}	$V_{33,34} = 50\text{mV}_{\text{rms}}$	1	0		0.5	mA
14	Integrator Current	I_{31}^*	$V_{33,34} = 50\text{mV}_{\text{rms}}$ $V_m = 3\text{V}$	1	-28	-38	-53	μA
15	Integrator Current	I_{31}^*	$V_{33,34} = 200\text{mV}_{\text{rms}}$ $V_m = 3\text{V}$	1	+30	+40	+55	μA
2nd AM IF section								
Mixer 2								
1	Max. Mixer gain	A_{M2}	$V_{17} = 1\text{mV}$; $V_{\text{out}} = V_{\text{IF}450}$ $f_{17} = 10.7\text{ MHz}$; $f_{14} = 10.25\text{ MHz}$	1	15	20	25	dB
2	Mixer AGC-range	ΔA	$\Delta A = A_{V17=1\text{mV}} - A_{V17=100\text{ mV}}$	1	15	20	25	dB
3	Mixer gain seek mode on		$V_{17} = 1\text{mV}$; $V_3 = 0.7\text{V}$	1	15	20	25	dB
4	Noise figure	F		Lab		10		dB
5	Integrator Current	I_{42}^*	$V_{17} = 0$ $V_m = 3\text{V}$	1	+70	+150	+250	μA
6	Integrator Current	I_{42}^*	$V_{17} = 100\text{mV}_{\text{rms}}$ $V_m = 3\text{V}$	1	-180	-270	-400	μA
2nd LO								
5	Operational frequency	f_{14}		1	9.25	10.25	11.25	MHz
6	External force voltage	V_{14}	$R_g = 600\Omega$; $C_k = 100\text{pF}$	1	30			mV_{rms}
7	Input Imp. Crystal Osc.	Z_{14}		Lab	-500	-600	-400	Ω
8	Crystal Resistance	R_{C1}	$P_{\text{TOTC}} = 50\mu\text{W}$; Fundamental	Lab			100	Ω
9	Spurious Harm. Cryst.	a_{SP}	$P_{\text{TOTC}} = 50\mu\text{W}$; $F < 30\text{ MHz}$	Lab	-20			dB
FM mode								
$f_{\text{IF}} = 10.7\text{ MHz}$								
$f_{35-36} = 100\text{ MHz}$								
$V_{43} = \text{open}$								
Mixer 1								
1	Interceptpoint 3rd order	I_{P3}	special testcircuit necessary	Lab		125		dB μV
2	Noise figure (10 MHz)	F	$R_{g\text{ opt}} = 500\Omega$	Lab		6		dB
3	Mixer gain	A_{M1}	$V_{35-36} = 10\text{mV}_{\text{rms}}$; $V_{\text{out}} = V_{23}$ ($R_F = 330\Omega$; $a_F = -4\text{dB}$)	Lab		9		dB
4	Over all gain	$A_{M\text{ IF}}$	$V_{35,36} = 10\text{mV}_{\text{rms}}$; $V_{\text{out}} = V_{\text{IF}10.7}$	1	25	32	39	dB
5	Input impedance	R_{35-36}	sym.	Lab	3.1	4	4.9	k Ω
6	Input impedance	C_{35-36}	sym.	Lab	1.5	2	2.5	pF
7	Input impedance	R_{35-36}	asym.	Lab	1.5	2	2.5	k Ω
8	Input impedance	C_{35-36}	asym.	Lab	3.1	4	4.9	pF
Prestage AGC output								
9	AGC voltage FM	V_{32}	$V_{35,36} = 0\text{mV}_{\text{rms}}$	1	5.2	6.4	7.7	V
10	AGC voltage FM	V_{32}	$V_{35,36} = 50\text{mV}_{\text{rms}}$	1	0		0.2	V
11	AGC current FM	I_{21}	$V_{35,36} = 0\text{ mV}_{\text{rms}}$	1	8.5	12	15	mA
12	AGC current FM	I_{21}	$V_{35,36} = 50\text{mV}_{\text{rms}}$	1	0		0.2	mA
13	AGC voltage AM	V_{28}	$V_{35,36} = 0$	1	0		1	V
14	Integrator Current	I_{32}^*	$V_{35} = 0$ $V_m = 4.8\text{V}$	1	-10	-25	-50	μA
15	Integrator Current	I_{32}^*	$V_{35} = 100\text{mV}_{\text{rms}}$ $V_m = 4.8\text{V}$	1	+40	+60	+85	μA

* Integrator currents are measured between the output pin (- Pole) of the measurement equipment and a voltage source V_m (+ Pole)

TUA 4300 G

AC / DC Characteristics

AC / DC characteristics involve the spread of values guaranteed within the specified supply voltage and ambient temperature range. Typical characteristics are the median of the production.

#	Parameter	Symbol	Test Conditions	Test Circuit	Min	Typ	Max	Units
2.FM Demodulator								
Measuring condition:								
$f_{iIF}=10.7\text{ MHz}; \Delta f=\pm 75\text{ kHz}; f_{mod}=1\text{ kHz}; V_7=10\text{ mV}_{rms}$								
$V_{44}=\text{open}; \text{Deemphasis}=100\ \mu\text{s}$								
1	Field strength output	V_{63}						
	-dynamic range	see Diagram D1		1	63	75		dB
	-nonlinearity	see Diagram D2		1		± 1		dB
	-temperature drift	see Diagram D3		1			± 3	dB
	-load capacitance						50	pF
	-load resistance				1			k Ω
		V_{63}	$V_7=200\text{mV}_{rms}$	1	4	4.6	5.2	V
		V_{63}	$V_7=1\text{mV}_{rms}$	1	1.4	1.9	2.4	V
		V_{63}	$V_7=0\text{mV}_{rms}$	1	0		1.5	V
2	AF-output voltage	$V_{58\text{ FM}}$	$R_L > 10\text{k}\Omega; \text{Deemph.}=100\ \mu\text{s}$	1	350	500	650	mV_{rms}
3	AF-output voltage	$V_{58\text{ FM}}$	$R_L > 10\text{k}\Omega; \text{no Deemph.}$	Lab		600		mV_{rms}
4	Input voltage for limiter threshold	V_7	$V_{58}=V_{58\text{ FM}} - 3\text{dB}$	1		33	45	μV_{rms}
5	Total harmonic distortion	THD_1		1			1.2	%
6	AM-suppression	a_{AM}	$m=30\%$	1	70	80		dB
7	Signal-to-noise ratio	$a_{S/N}$		1	72	80		dB
8	AF mute	a_{AF}	$V_{59}=0$	1	9	12	15	dB
Multipath detector								
$f_{57}=200\text{ kHz}$								
10	Attack current	$I_1^*)$	$V_{64AC}=1V_{pp}, V_m=5.0\text{ V}$	1	500	800	1100	μA
11	Recovery current	$I_1^*)$	$V_{64AC}=0; V_m=3.6\text{ V}$	1	-3	-9	-14	μA
12	Start voltage	V_{2Def}	$V_{57AC}=0\text{V}$	1	4.3	4.7		V
13	Detector characteristic	V_2	$f_{57}=25\text{kHz}; V_{57}=100\text{mV}_{pp}$	1	$V_{2Def}-0.15\text{V}$	$V_{2Def}-0.1\text{V}$	$V_{2Def}-0.05\text{V}$	V
14	Detector characteristic	V_2	$f_{57}=200\text{kHz}; V_{57}=100\text{mV}_{pp}$	1	$V_{2Def}-2.0\text{V}$	$V_{2Def}-1.6\text{V}$	$V_{2Def}-1.2\text{V}$	V

*) Integrator currents are measured between the output pin (- Pole of the measurement equipment) and a voltage source V_m (+ Pole)

TUA 4300 G

AC / DC Characteristics

AC / DC characteristics involve the spread of values guaranteed within the specified supply voltage and ambient temperature range. Typical characteristics are the median of the production.

#	Parameter	Symbol	Test Conditions	Test Circuit	Min	Typ	Max	Units
3.Stereodecoder								
Measuring condition:								
$V_{53}=600mV_{rms}$; $f=1\text{ kHz}$; 15kHz LP with 19kHz Notch; see appendix								
1	Total harmonic distortion	$THD_{47,48}$	$f=1\text{ kHz}$	1		0.1	0.5	%
2	Signal to noise ratio	$S/N_{47,48}$	Stereo	1	65	75		dB
3	Channel separation	a_{Sep}		1	26	40		dB
4	AF output voltage	$V_{47,48}$	Stereo	1	300	390	500	mV_{rms}
5	Overdrive margin	$V_{47,48\ max}$	THD= 1%1	3	8			dB
6	AF output DC voltage	$V_{DC\ 47,48}$		1	2.3	3	3.7	V
7	Difference of output voltage levels	$\Delta V_{47,48}$		1			2	dB
8	Muting depth	$A_{47,48}$	$V_{44}=0$	1	70	75		dB
9	Muting depth	$A_{47,48}$	$V_{44}=0.7V$	1	70	75		dB
10	DC-offset at mute	$\Delta_{DC\ 47,48}$		1	-100	0	100	mV
11	DC-offset stereo on/off	$\Delta_{DC\ 47,48}$		1	-100	0	100	mV

TUA 4300 G

AC / DC Characteristics

AC / DC characteristics involve the spread of values guaranteed within the specified supply voltage and ambient temperature range. Typical characteristics are the median of the production.

#	Parameter	Symbol	Test Conditions	Test Circuit	Min	Typ	Max	Units
---	-----------	--------	-----------------	--------------	-----	-----	-----	-------

Carrier and harmonic suppression (referenced to $V_{47,48}=390 \text{ mV}_{\text{rms}}$)

1	Pilotsignal (f=19kHz) subcarrier	α_{19}		1	40	45		dB
2	(f=38kHz)	α_{38}		1	40	50		dB
3	(f=57kHz)	α_{57}		1	40	50		dB

Mono/Stereo control

Pilot threshold voltage:

1	For stereo"on"	V_{PILon}		1		20	40	mV_{rms}
2	For stereo"off"	V_{PILoff}		1	2	15		mV_{rms}
3	Hysteresis		$V_{\text{PILon}} / V_{\text{PILoff}}$	1		3		dB

Stereo-indicator output

4	Pilot off	$V_{51\text{off}}$	$I_{51}=1\text{mA}$				0.5	V
5	Pilot on	$I_{51\text{on}}$	$V_{51}=8\text{V}$				10	μA

external control voltages (active low)

6	Operational voltage for external mono control (pin 52)	$V_{52\text{thr}}$		1			1	V
7	Operational voltage for AM/FM (pin 43)	$V_{43\text{thr}}$	AM on	1			1	V

Deemphasis

Reference frequency = 400Hz

 $C_{\text{deemph}}=10\text{nF}; \tau_{\text{nom}}=75 \mu\text{s}$

8	Minimum FM	$A_{\text{min FM}}$	$V_{49} \geq 3.8\text{V}; f_m=5\text{kHz}$	1	5.5	7.2	9.4	dB
9	Maximum FM	$A_{\text{max FM}}$	$V_{49} = 0\text{V}; f_m=5\text{kHz}$	1	11.5	14.5	19	dB
10	Minimum AM	$A_{\text{min AM}}$	$V_{49} \geq 4.4\text{V}; f_m=5\text{kHz}$	1	5.5	7.2	9.4	dB
11	Maximum AM	$A_{\text{max AM}}$	$V_{49} = 0\text{V}; f_m=5\text{kHz}$	1	10	14.5	19	dB

TUA 4300 G

AC / DC Characteristics

AC / DC characteristics involve the spread of values guaranteed within the specified supply voltage and ambient temperature range. Typical characteristics are the median of the production.

#	Parameter	Symbol	Test Conditions	Test Circuit	Min	Typ	Max	Units
Stereo/Mono blend control :								
1	Channel separation	a_{Sep}	$V_{50}=3.8V$	1	26			dB
2	Channel separation	a_{Sep}	$V_{50}=3.2V$	1			5	dB
Oscillator								
3	Max. Osc. frequency	f_{oscmax}	$100 \% \times (f_{max}/456kHz-1)$	1	0.7	1.0	2.0	%
4	Min. Osc. frequency	f_{oscmin}	$100 \% \times (f_{min}/456kHz-1)$	1	-2.0	-1.0	-0.7	%
5	VCO-gain	$\Delta f/\Delta V_{54}$		1	-13	-8	-3	kHz/V
6	Oscillator voltage	$V_{55 DC}$		1	2	4	6	V
7	Oscillator swing	$V_{55 AC}$		1	240	370	490	mV _{rms}
PLL								
8	PD-gain	$\Delta i/\Delta \phi$	$V_{pilot} = 54 \text{ mV}_{rms}$	note 1	5	8.2	11.2	$\mu A/rad$
Noise detector								
9	Input resistance	R_{57}		Lab	70	99	130	k Ω
10	Input high-pass filter	f_{in57}	-3dB	Lab	70	100	130	kHz
11	Trigger threshold	$V_{57 min}$	$V_{44} = V_{44} (V_{57 mean}=0) ,$ $f_{57}=200 \text{ kHz}$	1		30	60	mV _{rms}
12	Trigger threshold	$V_{57 dyn}$	$V_{44} = V_{44} (V_{57 mean}=50mV_{rms}) ,$ $f_{57}=200 \text{ kHz}$	1	110	170	260	mV _{rms}
13	Maximum noise mean value *	$V_{57 maxmean}$	$f_{57}=200 \text{ kHz}$	1	60	80	120	mV _{rms}
14	Suppression pulse duration			1	30	40	50	μs
15	Input offset current	$I_{45,46}$		Lab	-50	0	50	nA

*) The trigger threshold is adapted to the input noise. IF max. noise mean value is exceeded, threshold is too high for any trigger of the noise blanker.

TUA 4300 G

AC / DC Characteristics

AC / DC characteristics involve the spread of values guaranteed within the specified supply voltage and ambient temperature range. Typical characteristics are the median of the production.

#	Parameter	Symbol	Test Conditions	Test Circuit	Min	Typ	Max	Units
---	-----------	--------	-----------------	--------------	-----	-----	-----	-------

4.AM Mode**AGC-Amplifier**

Measuring condition:

$f_{iF} = 450 \text{ kHz}$; $f_{mod} = 1 \text{ kHz}$; $V_9 = 10 \text{ mV}_{rms}$, $Deemphasis = 100 \mu\text{s}$

1	AGC-range	ΔA	$V_{58} = V_{58AM} \pm 3 \text{ dB}$	1	64	80		dB
2	Input sensitivity	V_9	$V_{58} = V_{58AM} - 3 \text{ dB}$	1		30		μV_{rms}
3	AGC time seek mode on	V_{3L}		1	0		0.7	V
4	AGC time seek mode off	V_{3H}		1	2.4		5	V
5	Integrator Current	I_{13}^*	$V_9 = 0$; $V_m = 3 \text{ V}$	1	+70	+100	+130	μA
6	Integrator Current	I_{13}^*	$V_9 = 200 \text{ mV}_{rms}$; $V_m = 3 \text{ V}$	1	-70	-100	-130	μA
7	Integrator Current	I_{13}^*	$V_9 = 0$ $V_m = 3 \text{ V}$; $V_3 = 0.7 \text{ V}$	1	+450	+650	+845	μA
8	Integrator Current	I_{13}^*	$V_9 = 200 \text{ mV}_{rms}$; $V_m = 3 \text{ V}$; $V_3 = 0,7 \text{ V}$	1	-450	-650	-845	μA
9	Field strength output	V_{63}	$V_9 = 0 \text{ mV}$; seek mode off	1	0	0.3	0.8	V
10		V_{63}	$V_9 = 100 \mu\text{V}$; seek mode off	1	1.2	1.7	2.3	V
11		V_{63}	$V_9 = 500 \mu\text{V}$; seek mode off	1	2.2	2.7	3.2	V
12		V_{63}	$V_9 = 5 \text{ mV}$; seek mode off	1	3.3	4.1	4.9	V
13		V_{63}	$V_9 = 30 \text{ mV}$; seek mode off	1	3.8	4.6	5.4	V

Demodulator

17	AF output voltage	V_{58AM}	$m = 0.8$	1	335	480	650	mV_{rms}
18	AF output voltage	V_{1AM}	$m = 0.8$; $Deemph = 100 \mu\text{s}$	Lab	283	406	550	mV_{rms}
19	Total harm. distortion	THD_{64}	$m = 0.8$	1		0.7	2.5	%
20	(S+N)/N		$m = 0.8$; $V_9 = 20 \mu\text{V}$	1	20	30		dB
	(S+N)/N		$m = 0.8$; $V_9 = 200 \mu\text{V}$	1	40	50		dB
21	(S+N)/N		$m = 0.8$; $V_9 = 100 \text{ mV}_{rms}$	1	56	66		dB
22	AF-linearity	ΔV_{58}	$V_9 = 100 \mu\text{V} / 50 \text{ mV}$	1			3	dB

IF - Counter

23	IF - counter Output voltage	V_4	$R_L = 100 \text{ k}\Omega$ $V_3 = 0.7 \text{ V}$	1	285	400	580	mV_{rms}
24	IF-counter output voltage	V_4	$V_3 = 2.4 \text{ V}$	1			1	V_{DC}
25	IF-counter Output voltage	V_{4AC}	$V_3 = 2.4 \text{ V}$	1			2	mV_{rms}

*) Integrator currents are measured between the output pin (- Pole of the measurement equipment) and a voltage source V_m (+ Pole)

Test Circuit

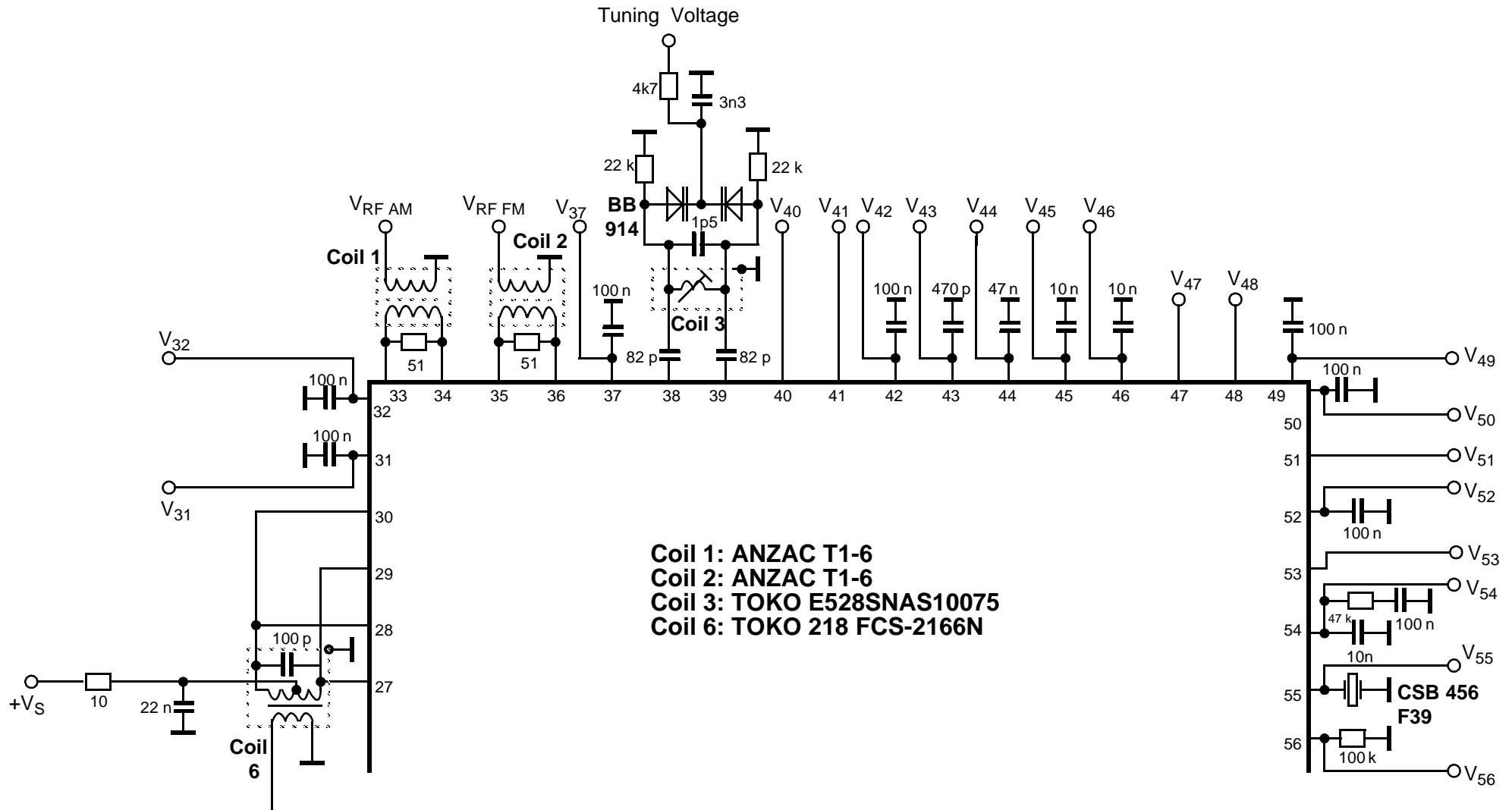

Test Circuit

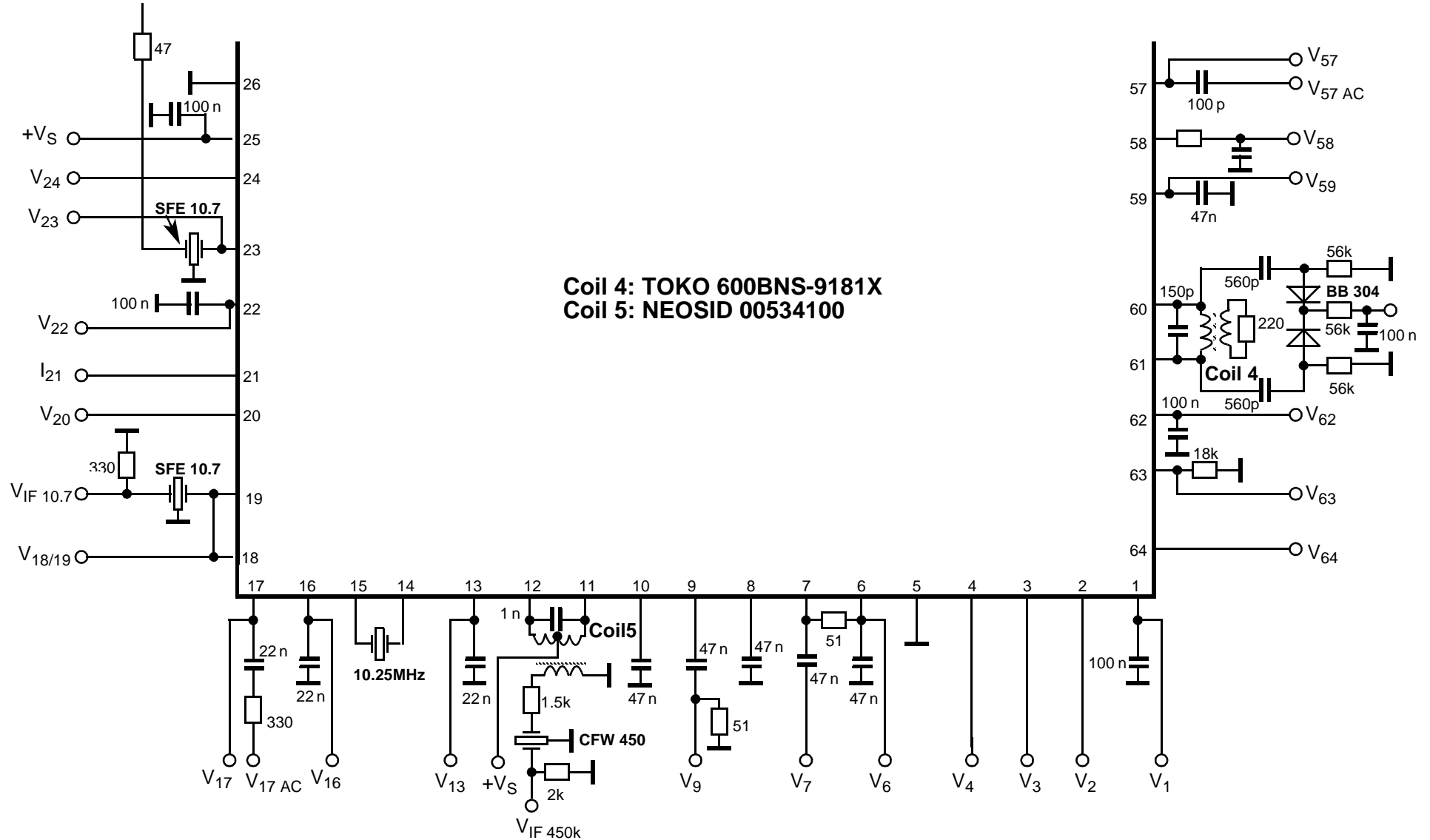

Application Circuit

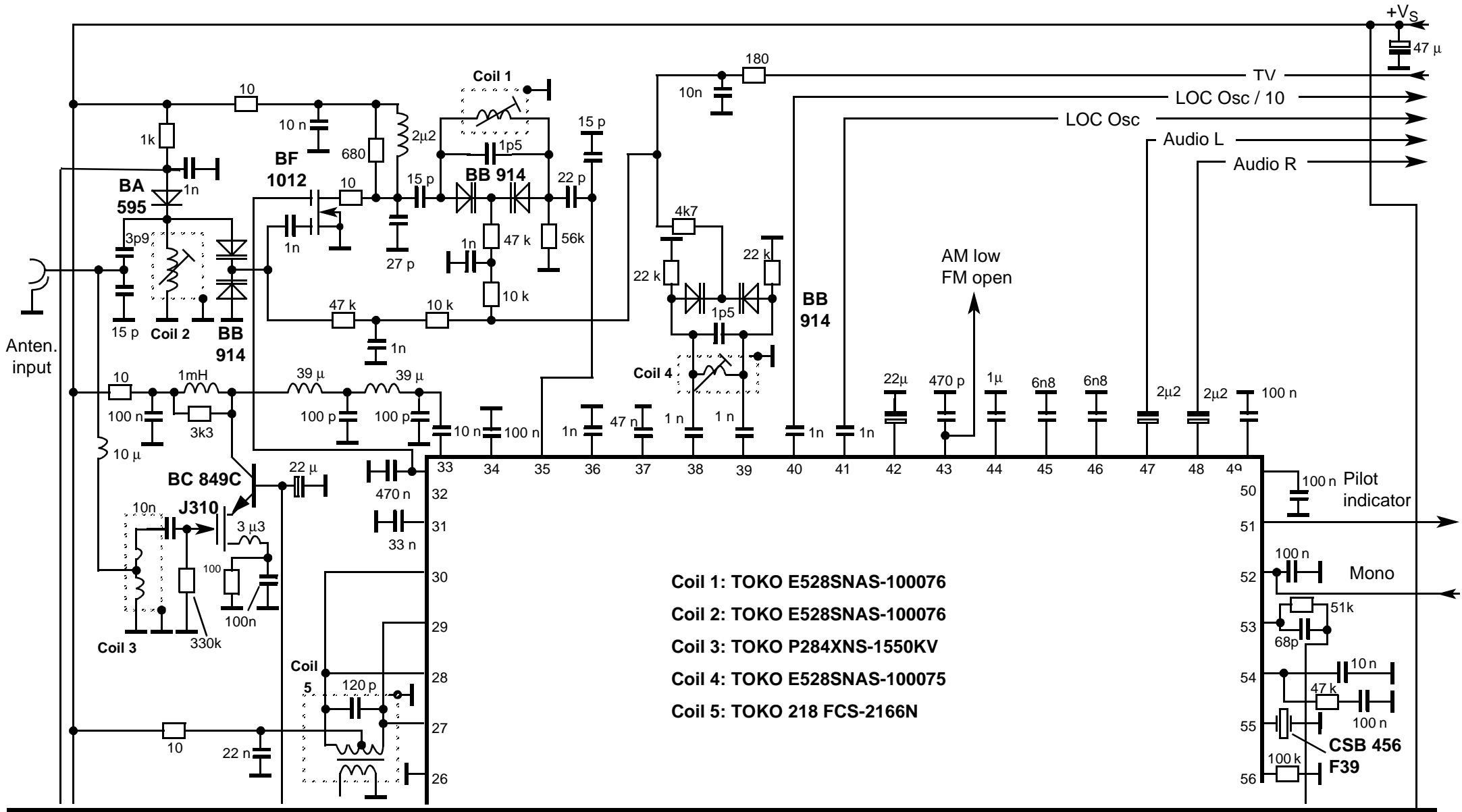

The reproduction, transmission or use of this document or its contents is not permitted without express written authority. Offenders will be liable for damages. All rights, including rights created by patent grant or registration of a utility model or design, are reserved.

Application Circuit

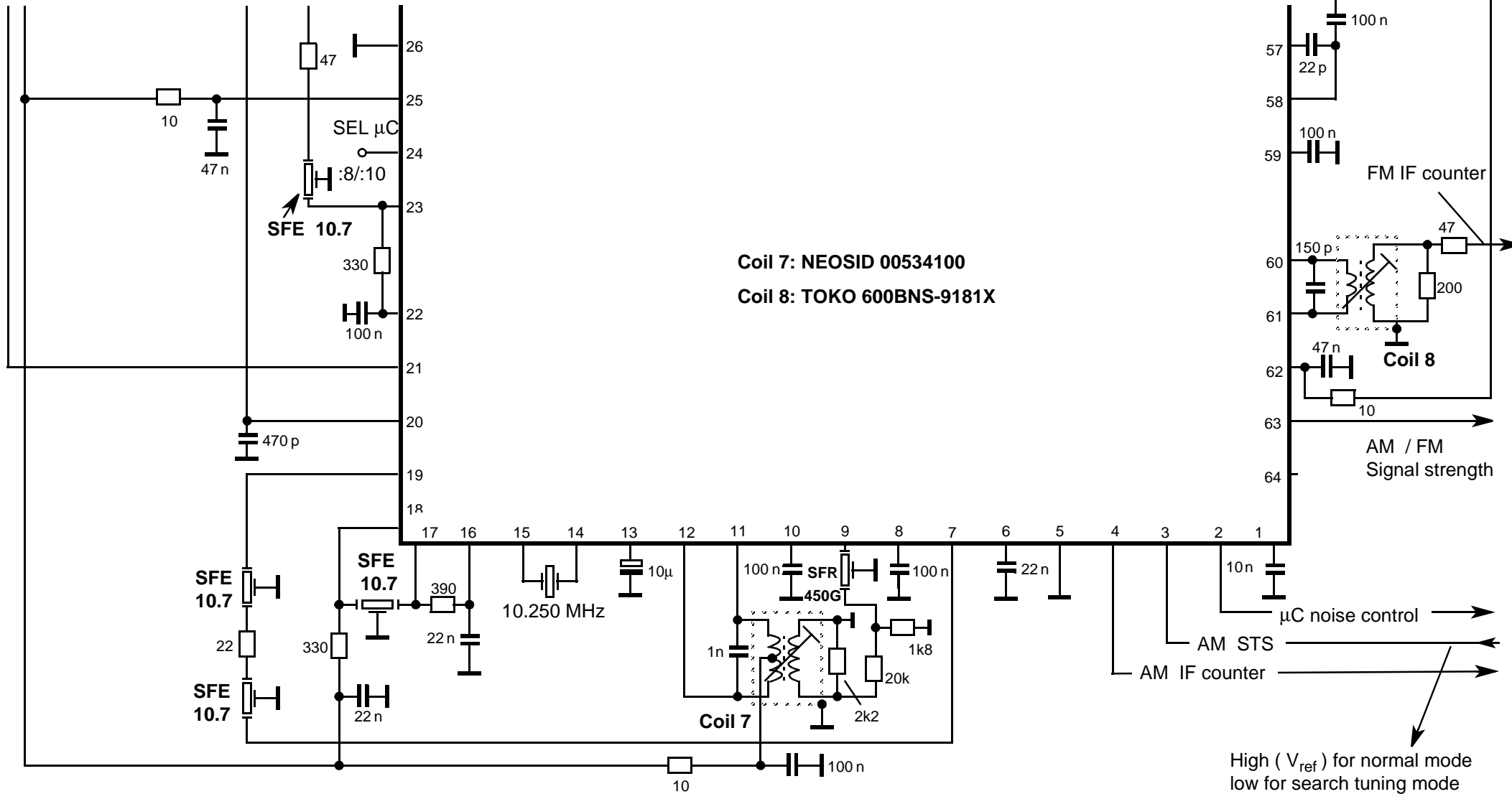

TUA 4300 G

Diagrams

Note 1: Definition of Phase Detector Gain

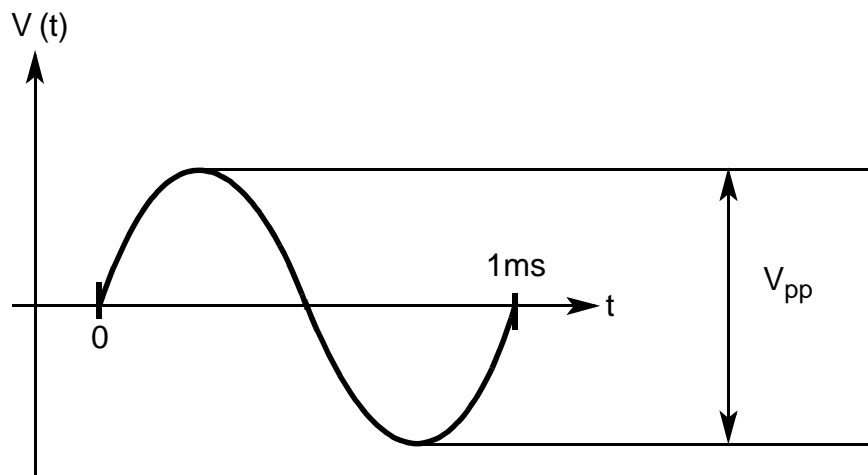
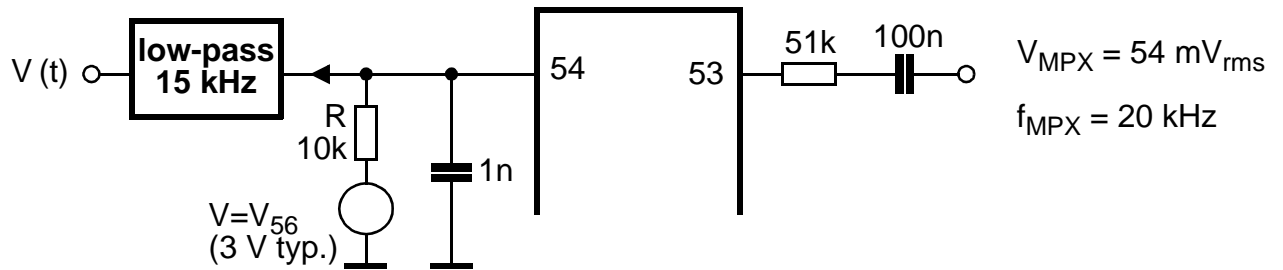

$$\text{Phase Detector Gain PDG} = \frac{V_{pp}}{2R} \text{ / rad}$$

TUA 4300 G

Diagrams

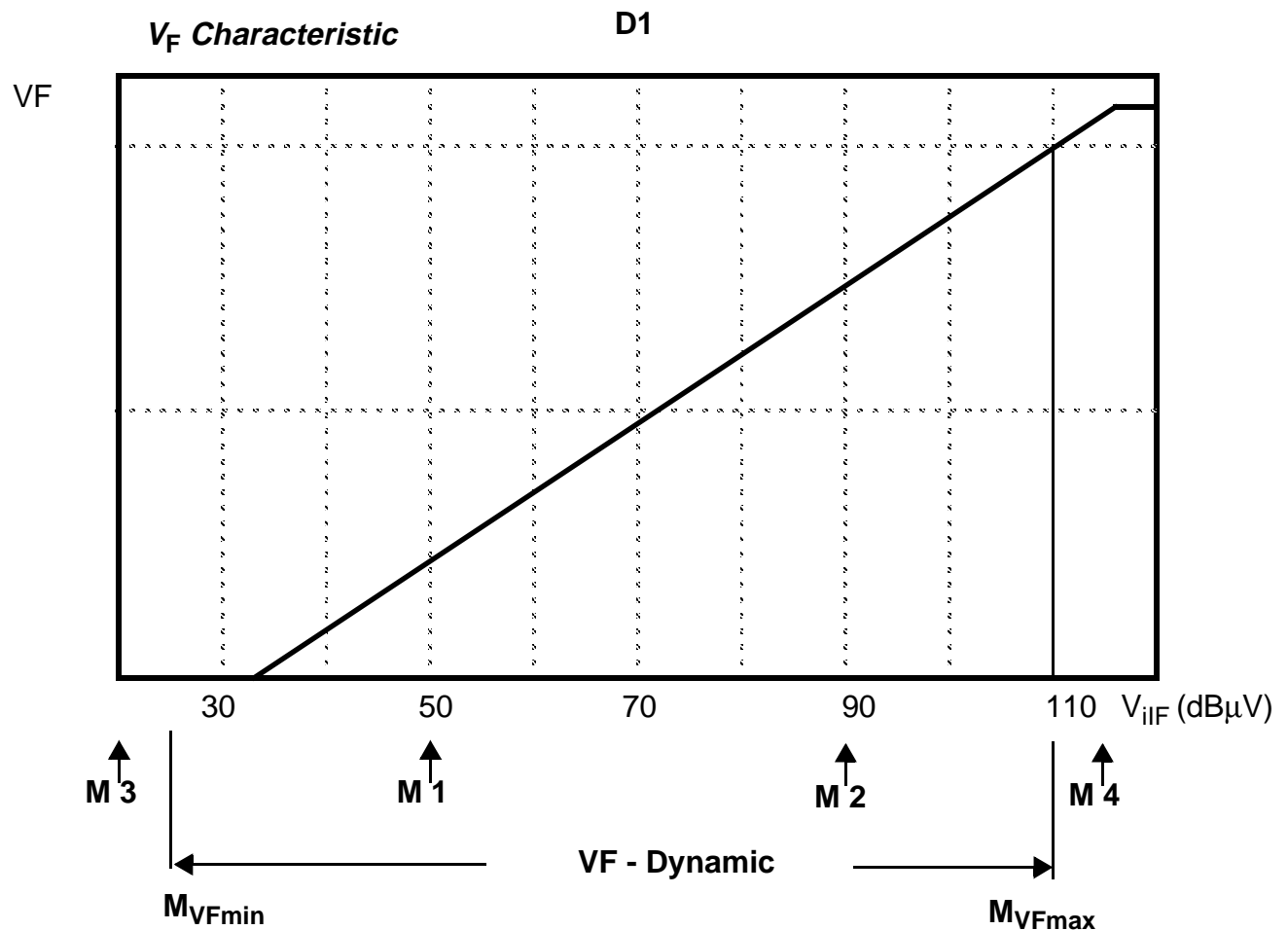

V_F - Dynamic : The dynamic range of V_F voltage is determined by the test points M1 through M4 as follows:

M1: test point (at $V_{iIF} = 50$ dB μ V) supplies V_F (M1)

M2: test point (at $V_{iIF} = 90$ dB μ V) supplies V_F (M2)

M3: test point (at $V_{iIF} = 20$ dB μ V) supplies V_F (M3)

M4: test point (at $V_{iIF} = 120$ dB μ V) supplies V_F (M4)

Hence follows :

$$M_{VFmax} := 90 \text{ dB}\mu\text{V} + \frac{V_F(M4) - V_F(M2)}{V_F(M2) - V_F(M1)} \times 40 \text{ dB}$$

$$M_{VFmin} := 50 \text{ dB}\mu\text{V} - \frac{V_F(M1) - V_F(M3)}{V_F(M2) - V_F(M1)} \times 40 \text{ dB}$$

$$\underline{\underline{VF - Dynamic}} = M_{VFmax} - M_{VFmin}$$

TUA 4300 G

Diagrams

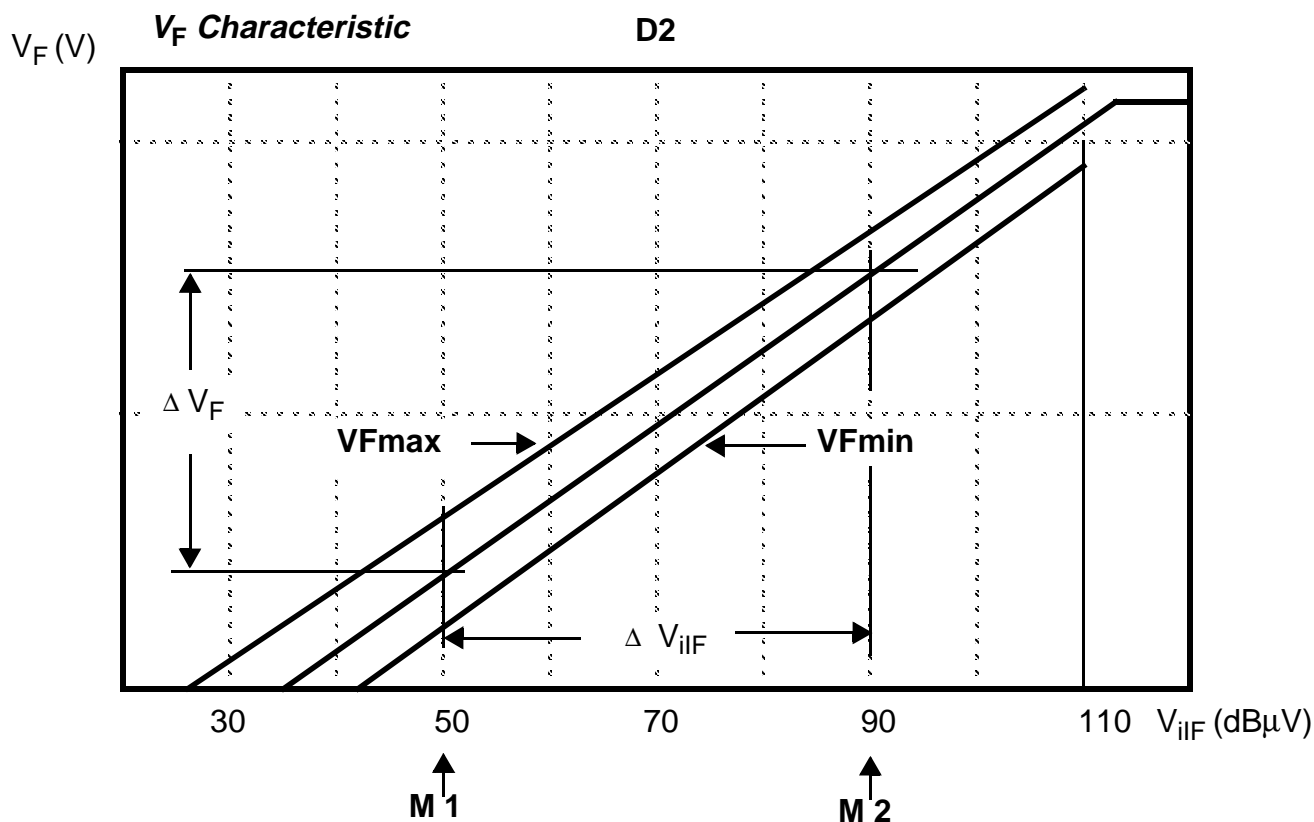

Test points to determine VF linearity

VF - Linearity: is determined at 25 °C

$$\text{Slope} : m = \frac{V_F (M2) - V_F (M1)}{40 \text{ dB}}$$

The tolerance range of the VF - linearity is determined by two parallel lines:

$$V_{Fmax} = V_F (M1) + m (M + 60 \text{ dB} + 1 \text{ dB})$$

$$V_{Fmin} = V_F (M1) + m (M + 60 \text{ dB} - 1 \text{ dB})$$

The V_F values within the V_F dynamic range ($M_{VFmin} \leq M \leq M_{VFmax}$) must be inside the predetermined tolerance range:

$$V_{Fmin} \leq V_F (M) \leq V_{Fmax}$$

TUA 4300 G

Diagrams

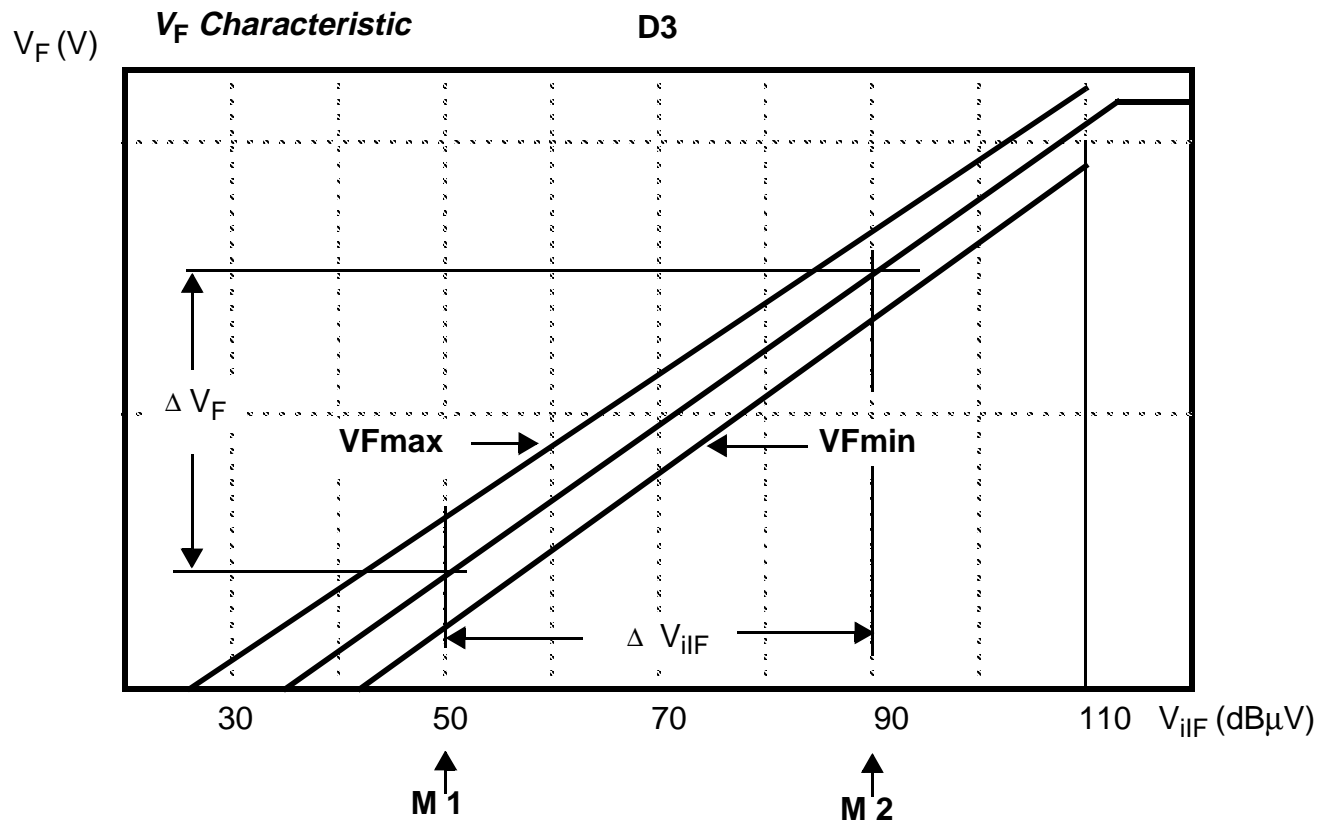

Test points to determine \$V_F\$ temperature drift

\$V_F\$ -Temperatur - Drift : It is determined within -40 bis +85 °C

$$\text{Slope} : m = \frac{V_F (M2) - V_F (M1)}{40 \text{ dB}} \quad (\text{at } 25 \text{ }^\circ\text{C})$$

The tolerance range of the \$V_F\$ temperature drift is determined by two parallel lines:

$$V_{Fmax} = V_F (M1) + m (M + 60 \text{ dB} + 3\text{dB})$$

$$V_{Fmin} = V_F (M1) + m (M + 60 \text{ dB} - 3\text{dB})$$

The \$V_F\$ values for temperatures between -40 to +85 °C within the \$V_F\$ dynamic range (\$M_{VFmin} \le V_F \le M_{VFmax}\$) must be inside the predetermined tolerance field:

$$V_{Fmin} \le V_F (M) \le V_{Fmax}$$

TUA 4300 G

Appendix

AC / DC characteristics involve the spread of values guaranteed within the specified supply voltage and ambient temperature range. Typical characteristics are the median of the production.

#	Parameter	Symbol	Test Conditions	Test Circuit	Min	Typ	Max	Units
---	-----------	--------	-----------------	--------------	-----	-----	-----	-------

AC / DC Characteristics

Intermodulation behaviour Stereodecoder section

Referenced to $V_{47,48} = 390 \text{ mV}_{\text{rms}}$

1	$f_{\text{mod}} = 10 \text{ kHz}$	α_2	91% Mono, 9% Pilot $f_s = 1 \text{ kHz}$ $f_s = 2 \times 10 \text{ kHz} - 19 \text{ kHz}$	Lab		60		dB
2	$f_{\text{mod}} = 13 \text{ kHz}$	α_3	$f_s = 3 \times 13 \text{ kHz} - 38 \text{ kHz}$	Lab		70		dB
3	$f = 57 \text{ kHz}$	α_{57}	91% Mono, 9% Pilot $f_m = 1 \text{ kHz}$ 5% Traffic Radio Carrier ($f = 57 \text{ kHz}; f_m = 23 \text{ Hz}; m = 60\%$) $f_s = 1 \text{ kHz} \pm 23 \text{ Hz}$	Lab		70		dB

Low pass filter with 19 kHz Notch

