

## DM74AS257 • DM74AS258

### 3-STATE Quad 1 of 2 Line Data Selector/Multiplexers

#### General Description

These data selectors/multiplexers contain inverters and drivers to supply full on-chip data selection to the four 3-STATE outputs that can interface directly with data lines of bus-organized systems. A 4-bit word selected from one of two sources is routed to the four outputs. The DM74AS257 presents true data whereas the DM74AS258 presents inverted data to minimize propagation delay time.

This 3-STATE output feature means that n-bit (paralleled) data selectors with up to 300 sources can be implemented for data buses. It also permits the use of standard TTL registers for data retention throughout the system.

#### Features

- Switching specifications at 50 pF
- Switching specifications guaranteed over full temperature and  $V_{CC}$  range
- Advanced oxide-isolated, ion-implanted Schottky TTL process
- Functionally and pin for pin compatible with Schottky, low power Schottky, and advanced low power Schottky TTL counterpart
- Improved AC performance over Schottky, low power Schottky, and advanced low power Schottky counterparts
- 3-STATE buffer-type output drive bus lines directly
- Expand any data input point
- Multiplex dual data buses
- General four functions of two variables (one variable is common)
- Source programmable counters

#### Ordering Code:

Order Number	Package Number	Package Description
DM74AS257M	M16A	16-Lead Small Outline Integrated Circuit (SOIC), JEDEC MS-012, 0.150 Narrow
DM74AS257N	N16E	16-Lead Plastic Dual-In-Line Package (PDIP), JEDEC MS-001, 0.300 Wide
DM74AS258M	M16A	16-Lead Small Outline Integrated Circuit (SOIC), JEDEC MS-012, 0.150 Narrow
DM74AS258N	N16E	16-Lead Plastic Dual-In-Line Package (PDIP), JEDEC MS-001, 0.300 Wide

Devices also available in Tape and Reel. Specify by appending the suffix letter "X" to the ordering code.

#### Connection Diagram

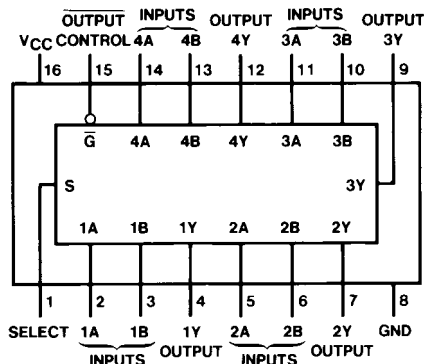

#### Function Table

OUTPUT CONTROL	INPUTS			OUTPUT Y	
	SELECT	A	B	AS257	AS258
H	X	X	X	Z	Z
L	L	L	X	L	H
L	L	H	X	H	L
L	H	X	L	L	H
L	H	X	H	H	L

H = HIGH Level  
L = LOW Level  
X = Don't Care  
Z = High Impedance (OFF)

Logic Diagrams

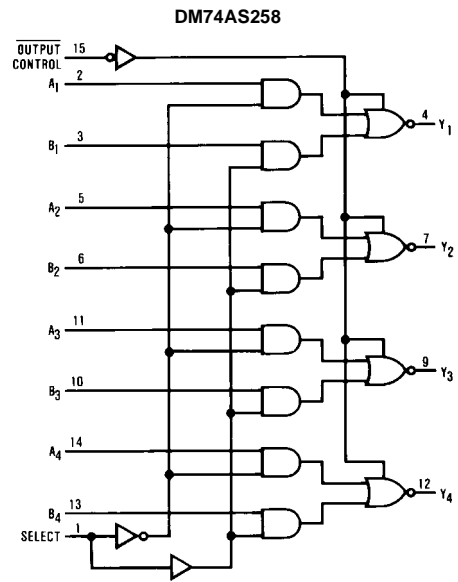
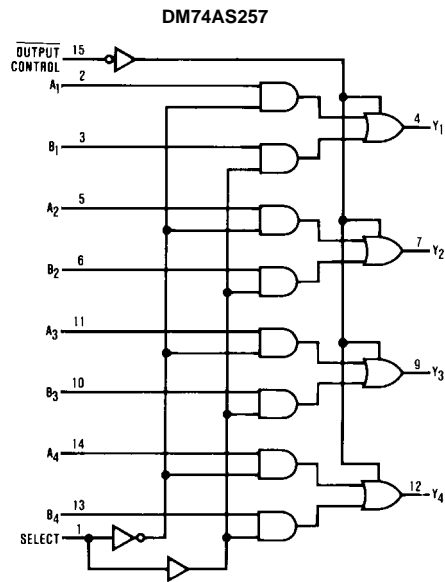

**Absolute Maximum Ratings**(Note 1)

Supply Voltage, $V_{CC}$	7V
Input Voltage	7V
Voltage Applied to Disabled Output	5.5V
Operating Free Air Temperature Range	0°C to +70°C
Storage Temperature Range	-65°C to +150°C
Typical $\theta_{JA}$	
N Package	75.0°C/W

**Note 1:** The "Absolute Maximum Ratings" are those values beyond which the safety of the device cannot be guaranteed. The device should not be operated at these limits. The parametric values defined in the Electrical Characteristics tables are not guaranteed at the absolute maximum ratings. The "Recommended Operating Conditions" table will define the conditions for actual device operation.

**Recommended Operating Conditions**

Symbol	Parameter	Min	Nom	Max	Units
$V_{CC}$	Supply Voltage	4.5	5	5.5	V
$V_{IH}$	HIGH Level Input Voltage	2			V
$V_{IL}$	LOW Level Input Voltage			0.8	V
$I_{OH}$	HIGH Level Output Current			-15	mA
$I_{OL}$	LOW Level Output Current			48	mA
$T_A$	Free Air Operating Temperature	0		70	°C

**Electrical Characteristics**

over recommended operating free air temperature range. All typical values are measured at  $V_{CC} = 5V$ ,  $T_A = 25^\circ C$ .

Symbol	Parameter	Conditions	Min	Typ	Max	Units		
$V_{IK}$	Input Clamp Voltage	$V_{CC} = 4.5V$ , $I_I = -18 mA$			-1.2	V		
$V_{OH}$	HIGH Level Output Voltage	$V_{CC} = 4.5V$ , $I_{OH} = Max$	2.4	3.2		V		
		$I_{OH} = -2 mA$ , $V_{CC} = 4.5V$ to $5.5V$	$V_{CC} - 2$			V		
$V_{OL}$	LOW Level Output Voltage	$V_{CC} = 4.5V$ , $I_{OL} = Max$		0.35	0.5	V		
$I_I$	Input Current @ Max Input Voltage	$V_{CC} = 5.5V$ , $V_{IH} = 7V$	A, B, $\bar{G}$		0.1	mA		
			Select		0.2			
$I_{IH}$	HIGH Level Input Current	$V_{CC} = 5.5V$ , $V_{IH} = 2.7V$	A, B, $\bar{G}$		20	$\mu A$		
			Select		40			
$I_{IL}$	LOW Level Input Current	$V_{CC} = 5.5V$ , $V_{IL} = 0.4V$	Select		-1	mA		
			All Others		-0.5			
$I_O$ (Note 2)	Output Drive Current	$V_{CC} = 5.5V$ , $V_O = 2.25V$	-30		-112	mA		
$I_{OZH}$	Off-State Output Current, HIGH Level Voltage Applied	$V_{CC} = 5.5V$ , $V_O = 2.7V$			-50	$\mu A$		
$I_{OZL}$	Off-State Output Current, LOW Level Voltage Applied	$V_{CC} = 5.5V$ , $V_O = 0.4V$			-50	$\mu A$		
$I_{CCH}$	Supply Current	DM74AS257 DM74AS258	$V_{CC} = 5.5V$	Outputs HIGH		12.9	19.7	mA
						8.8	13.5	mA
$I_{CCL}$	Supply Current	DM74AS257 DM74AS258	$V_{CC} = 5.5V$	Outputs LOW		19	30.6	mA
						15.8	24.6	mA
$I_{CCZ}$	Supply Current	DM74AS257 DM74AS258	$V_{CC} = 5.5V$	Outputs Disabled		19.7	31.9	mA
						15.5	25.2	mA

**Note 2:** The output conditions have been chosen to produce a current that closely approximates one half of the true short-circuit output current,  $I_{OS}$ .

**DM74AS257 Switching Characteristics**

over recommended operating free air temperature range

Symbol	Parameter	From	To	Conditions	Min	Max	Units
$t_{PLH}$	Propagation Delay Time, LOW-to-HIGH Level Output	Data	Any Y	$V_{CC} = 4.5V$ to $5.5V$ , $C_L = 50$ pF, $R_L = 500\Omega$	1	5.5	ns
$t_{PHL}$	Propagation Delay Time, HIGH-to-LOW Level Output				1	6	ns
$t_{PLH}$	Propagation Delay Time, LOW-to-HIGH Level Output	Select	Any Y		2	11	ns
$t_{PHL}$	Propagation Delay Time, HIGH-to-LOW Level Output				2	10	ns
$t_{PZH}$	Output Enable Time to HIGH Level	OUTPUT Control	Any Y		2	7.5	ns
$t_{PZL}$	Output Enable Time to LOW Level				2	9.5	ns
$t_{PHZ}$	Output Disable Time, from HIGH Level	OUTPUT Control	Any Y		1.5	6.5	ns
$t_{PLZ}$	Output Disable Time, from LOW Level				2	7	ns

**DM74AS258 Switching Characteristics**

over recommended operating free air temperature range

Symbol	Parameter	From	To	Conditions	Min	Max	Units
$t_{PLH}$	Propagation Delay Time, LOW-to-HIGH Level Output	Data	Any Y	$V_{CC} = 4.5V$ to $5.5V$ , $C_L = 50$ pF, $R_L = 500\Omega$	1	5	ns
$t_{PHL}$	Propagation Delay Time, HIGH-to-LOW Level Output				1	4	ns
$t_{PLH}$	Propagation Delay Time, LOW-to-HIGH Level Output	Select	Any Y		2	9.5	ns
$t_{PHL}$	Propagation Delay Time, HIGH-to-LOW Level Output				2	10	ns
$t_{PZH}$	Output Enable Time to HIGH Level	OUTPUT Control	Any Y		2	8	ns
$t_{PZL}$	Output Enable Time to LOW Level				2	10	ns
$t_{PHZ}$	Output Disable Time, from HIGH Level	OUTPUT Control	Any Y		1.5	6	ns
$t_{PLZ}$	Output Disable Time, from LOW Level				2	6.5	ns

**Physical Dimensions** inches (millimeters) unless otherwise noted

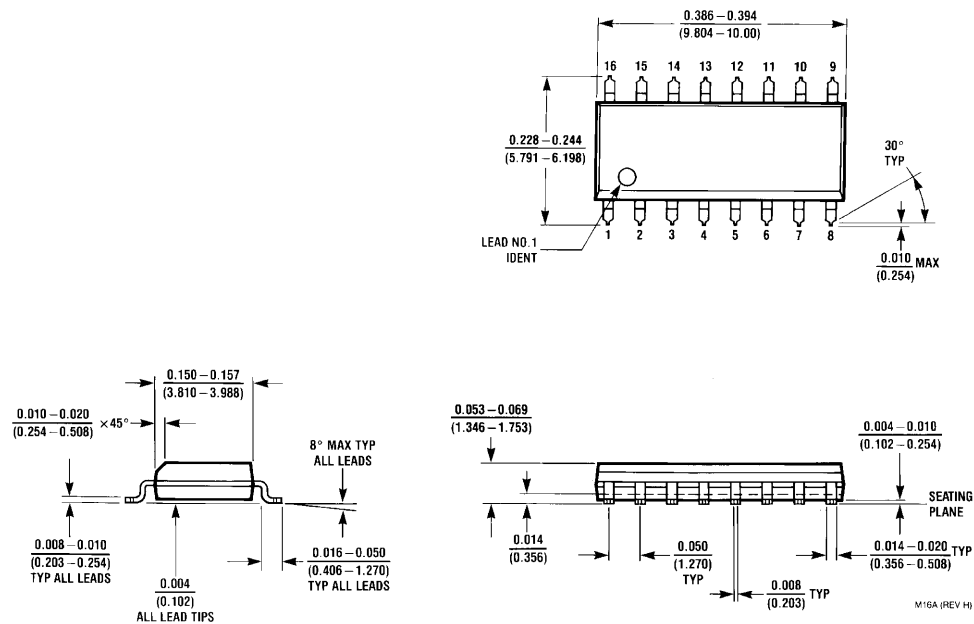

**16-Lead Small Outline Integrated Circuit (SOIC), JEDEC MS-012, 0.150 Narrow Package Number M16A**

**Physical Dimensions** inches (millimeters) unless otherwise noted (Continued)

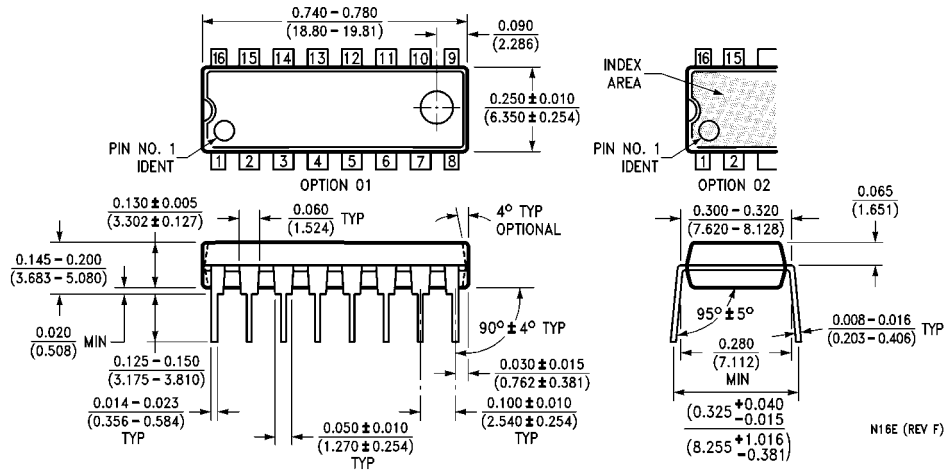

16-Lead Plastic Dual-In-Line Package (PDIP), JEDEC MS-001, 0.300 Wide Package Number N16E

Fairchild does not assume any responsibility for use of any circuitry described, no circuit patent licenses are implied and Fairchild reserves the right at any time without notice to change said circuitry and specifications.

**LIFE SUPPORT POLICY**

FAIRCHILD'S PRODUCTS ARE NOT AUTHORIZED FOR USE AS CRITICAL COMPONENTS IN LIFE SUPPORT DEVICES OR SYSTEMS WITHOUT THE EXPRESS WRITTEN APPROVAL OF THE PRESIDENT OF FAIRCHILD SEMICONDUCTOR CORPORATION. As used herein:

1. Life support devices or systems are devices or systems which, (a) are intended for surgical implant into the body, or (b) support or sustain life, and (c) whose failure to perform when properly used in accordance with instructions for use provided in the labeling, can be reasonably expected to result in a significant injury to the user.
2. A critical component in any component of a life support device or system whose failure to perform can be reasonably expected to cause the failure of the life support device or system, or to affect its safety or effectiveness.

[www.fairchildsemi.com](http://www.fairchildsemi.com)