

DM74ALS151

1 of 8 Line Data Selector/Multiplexer

General Description

This Data Selector/Multiplexer contains full on-chip decoding to select one-of-eight data sources as a result of a unique three-bit binary code at the Select inputs. Two complementary outputs provide both inverting and non-inverting buffer operation. A Strobe input is provided which, when at the high level, disables all data inputs and forces the Y output to the LOW state and the W output to the HIGH state. The Select input buffers incorporate internal overlap features to ensure that select input changes do not cause invalid output transients.

Features

- Advanced oxide-isolated, ion-implanted Schottky TTL process
- Switching performance is guaranteed over full temperature and V_{CC} supply range
- Pin and functional compatible with LS family counterpart
- Improved output transient handling capability

Ordering Code:

Order Number	Package Number	Package Description
DM74ALS151M	M16A	16-Lead Small Outline Integrated Circuit (SOIC), JEDEC MS-012, 0.150 Narrow
DM74ALS151N	N16E	16-Lead Plastic Dual-In-Line Package (PDIP), JEDEC MS-001, 0.300 Wide

Devices also available in Tape and Reel. Specify by appending the suffix letter "X" to the ordering code.

Connection Diagram

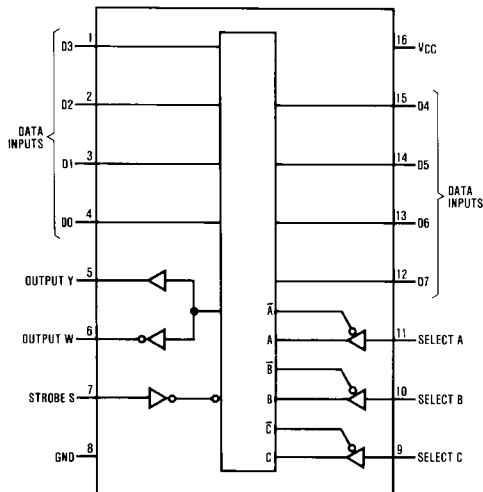

Function Table

Inputs				Outputs	
Select			Strobe S	Y	W
C	B	A			
X	X	X	H	L	H
L	L	L	L	D0	$\overline{D0}$
L	L	H	L	D1	$\overline{D1}$
L	H	L	L	D2	$\overline{D2}$
L	H	H	L	D3	$\overline{D3}$
H	L	L	L	D4	$\overline{D4}$
H	L	H	L	D5	$\overline{D5}$
H	H	L	L	D6	$\overline{D6}$
H	H	H	L	D7	$\overline{D7}$

H = HIGH Level
L = LOW Level
X = Don't Care
D0 thru D7 = the level of the respective D input

DM74ALS151

Logic Diagram

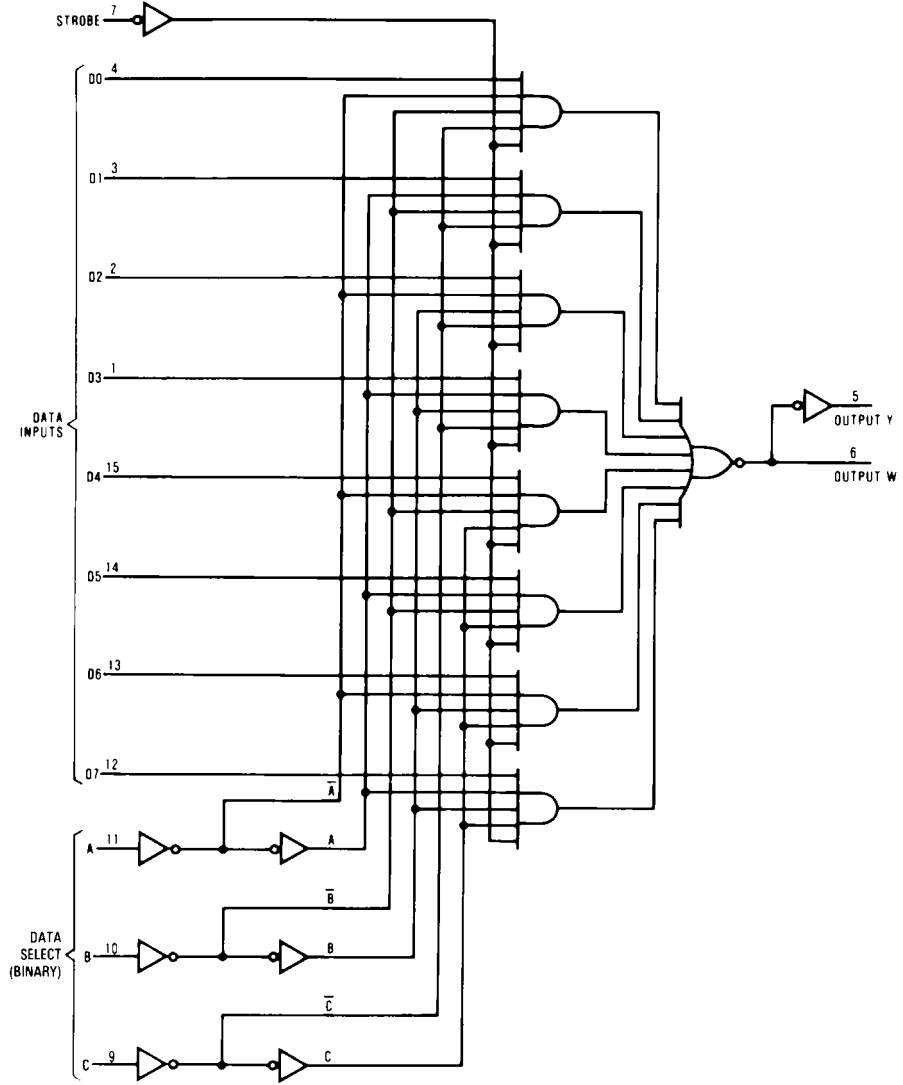

Absolute Maximum Ratings(Note 1)

Supply Voltage	7V
Input Voltage	7V
Operating Free Air Temperature Range	0°C to +70°C
Storage Temperature Range	-65°C to +150°C
Typical θ_{JA}	
N Package	78.0°C/W
M Package	107.0°C/W

Note 1: The "Absolute Maximum Ratings" are those values beyond which the safety of the device cannot be guaranteed. The device should not be operated at these limits. The parametric values defined in the Electrical Characteristics tables are not guaranteed at the absolute maximum ratings. The "Recommended Operating Conditions" table will define the conditions for actual device operation.

Recommended Operating Conditions

Symbol	Parameter	Min	Nom	Max	Units
V_{CC}	Supply Voltage	4.5	5	5.5	V
V_{IH}	HIGH Level Input Voltage	2			V
V_{IL}	LOW Level Input Voltage			0.8	V
I_{OH}	HIGH Level Output Current			-2.6	mA
I_{OL}	LOW Level Output Current			24	mA
T_A	Free Air Operating Temperature	0		70	°C

Electrical Characteristics

over recommended operating free-air temperature range. All typical values are measured at $V_{CC} = 5V$, $T_A = 25^\circ C$.

Symbol	Parameter	Conditions	Min	Typ	Max	Units
V_{IK}	Input Clamp Voltage	$V_{CC} = 4.5V$, $I_{IN} = -18\text{ mA}$			-1.5	V
V_{OH}	HIGH Level Output Voltage	$V_{CC} = 4.5V$, $I_{OH} = \text{Max}$	2.4	3.2		V
		$I_{OH} = -400\ \mu A$, $V_{CC} = 4.5V\text{ to }5.5V$	$V_{CC} - 2$			V
V_{OL}	LOW Level Output Voltage	$V_{CC} = 4.5V$, $I_{OL} = 24\text{ mA}$		0.35	0.5	V
I_i	Input Current at Maximum Input Voltage	$V_{CC} = 5.5V$, $V_{IN} = 7V$			0.1	mA
I_{IH}	HIGH Level Input Current	$V_{CC} = 5.5V$, $V_{IN} = 2.7V$			20	μA
I_{IL}	LOW Level Input Current	$V_{CC} = 5.5V$, $V_{IN} = 0.4V$			-0.1	mA
I_O	Output Drive Current	$V_{CC} = 5.5V$, $V_{OUT} = 2.25V$	-30		-112	mA
I_{CC}	Supply Current	$V_{CC} = 5.5V$ All Inputs = 4.5V		7.5	12	mA

Switching Characteristics

over recommended operating free air temperature range

Symbol	Parameter	Conditions	From	To	Min	Max	Units
t_{PLH}	Propagation Delay Time LOW-to-HIGH Level Output	$V_{CC} = 4.5V$ to $5.5V$ $C_L = 50$ pF $R_L = 500\Omega$	Select	Y	4	18	ns
t_{PHL}	Propagation Delay Time HIGH-to-LOW Level Output		Select	Y	8	24	ns
t_{PLH}	Propagation Delay Time LOW-to-HIGH Level Output		Select	W	7	24	ns
t_{PHL}	Propagation Delay Time HIGH-to-LOW Level Output		Select	W	7	23	ns
t_{PLH}	Propagation Delay Time LOW-to-HIGH Level Output		Data	Y	3	10	ns
t_{PHL}	Propagation Delay Time HIGH-to-LOW Level Output		Data	Y	5	15	ns
t_{PLH}	Propagation Delay Time LOW-to-HIGH Level Output		Data	W	3	15	ns
t_{PHL}	Propagation Delay Time HIGH-to-LOW Level Output		Data	W	4	15	ns
t_{PLH}	Propagation Delay Time LOW-to-HIGH Level Output		Strobe	Y	4	18	ns
t_{PHL}	Propagation Delay Time HIGH-to-LOW Level Output		Strobe	Y	4	19	ns
t_{PLH}	Propagation Delay Time LOW-to-HIGH Level Output		Strobe	W	5	19	ns
t_{PHL}	Propagation Delay Time HIGH-to-LOW Level Output		Strobe	W	5	23	ns

Physical Dimensions inches (millimeters) unless otherwise noted

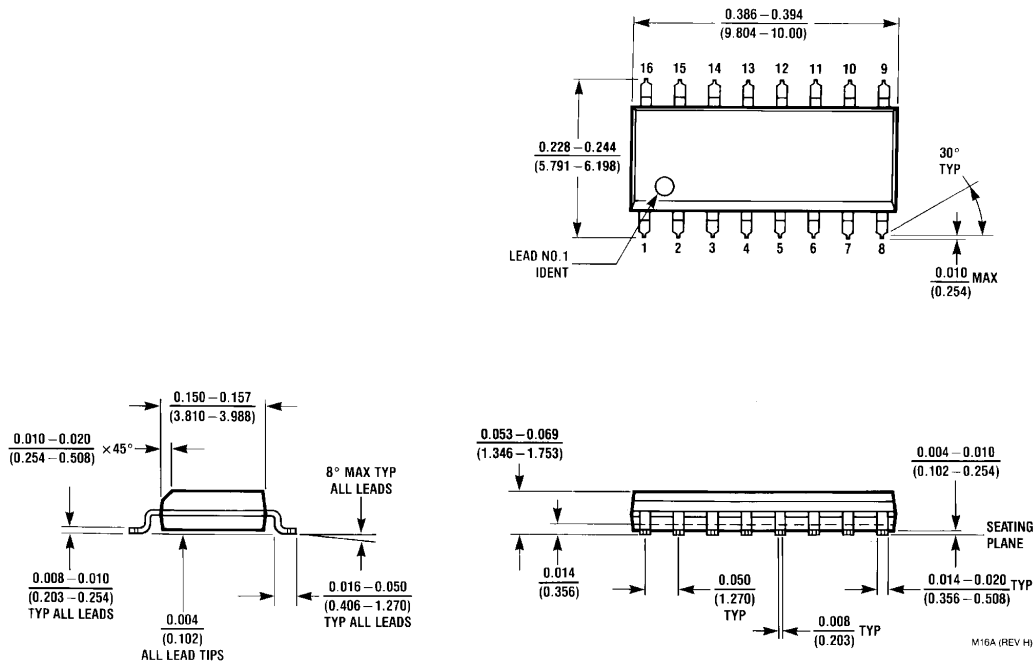

**16-Lead Small Outline Integrated Circuit (SOIC), JEDEC MS-012, 0.150 Narrow
Package Number M16A**

