

Type	Ordering code	Package
TDA 4290-2	Q 67000-A 1359	} DIP 14
TDA 4290-2 S	Q67000-A1359-E20	

Tone control IC for the DC voltage control of volume, treble, and bass. The volume characteristic can be changed from linear to physiological.

For mono application we recommend the TDA 4290-2, while the TDA 4290-2 S is especially suitable for stereo application.

Features

- Few external components
- High signal-to-noise ratio
- Low total harmonic distortion
- Complies with the IEC 268-3 standards

Maximum ratings

Supply voltage	V_S	18	V
Control inputs	V_5, V_8, V_{14}	0 to V_S	V
Input signal	$V_{8\text{rms}}$	3	V
Load current	I_2	10	mA
Junction temperature	T_j	150	°C
Storage temperature range	T_{stg}	-40 to 125	°C
Thermal resistance (system-air)	R_{thSA}	90	K/W

Operating range

Supply voltage	V_S	10.5 to 18	V
Volume control	V_5	0 to $0.51 \times V_2$	V
Frequency (-1 dB)	f_i	20 to 20,000	Hz
Ambient temperature	T_A	0 to 70	°C

Characteristics

$V_S = 14\text{ V}$; $T_A = 25^\circ\text{C}$

Measurement circuit 1

	min	typ	max	
Current consumption		35	50	mA
Reference voltage	4.5	4.85	5.2	V
Input resistance	2.9	3.9		k Ω
Output resistance		200		Ω
Changeover current		3.5		mA
Input current for set inputs		4	20	μA
$V_{5/8/14} = 0.5 \times V_2$				

Attenuation

$V_{i\text{rms}} = 300\text{ mV}$, $f_i = 1.6\text{ kHz}$, $V_8 = 0.5 \times V_2$, $V_{14} = 0.49 \times V_2$, S1 on physiological

$V_5 = 0.51 \times V_2$	$V_{q0} = V_q/V_i$	-3	0	3	dB
$V_5 = 0.41 \times V_2$	V_q/V_{q0}	-17	-15	-13	dB
$V_5 = 0.33 \times V_2$	V_q/V_{q0}	-33	-30	-27	dB
$V_5 = 0.25 \times V_2$	V_q/V_{q0}	-48	-44	-40	dB
Max. attenuation	V_q/V_{q0}	-75	-80		dB

Frequency response

$V_{i\text{rms}} = 300\text{ mV}$, $V_5 = 0.51 \times V_2$, S1 any

Linearity $V_8 = 0.5 \times V_2$ $V_{14} = 0.49 \times V_2$, $f = 40$ to $15,000\text{ Hz}$	V_q/V_{q8}	-3	0	3	dB
Influence at $f = 1\text{ kHz}$ Trebles/basses max. Trebles/basses min.	V_q/V_{q0} V_q/V_{q0}		2 -2	3	dB dB
Treble emphasis $f_i = 15\text{ kHz}$, $V_{14} = V_2$, $V_8 = 0.5 \times V_2$	V_q/V_{q80}	+15	+17		dB
Treble deemphasis $f_i = 15\text{ kHz}$, $V_{14} = 0\text{ V}$, $V_8 = 0.5 \times V_2$	V_q/V_{q80}		-17	-15	dB
Bass emphasis $f_i = 40\text{ Hz}$, $V_8 = V_2$, $V_{14} = 0.49 \times V_2$	V_q/V_{q80}	+15	+17		dB
Bass deemphasis $f_i = 40\text{ Hz}$, $V_8 = 0\text{ V}$, $V_{14} = 0.49 \times V_2$	V_q/V_{q80}		-17	-15	dB
Total harmonic distortion $V_{i\text{rms}} = 300\text{ mV}$, $f_i = 40\text{ Hz}$ to 15 kHz , control unit in 0 dB position	THD		0.1	0.5	%
Disturbance voltage $f_i = 20$ to $20,000\text{ Hz}$, tone control in 0 dB position, volume -20 dB	$V_{d\text{rms}}$		30	50	μV

Physiology tone control in 0 dB position

$V_{i\text{rms}} = 300 \text{ mV}$, S1 at physiology

$f = 1.6 \text{ kHz}$		$f = 40 \text{ Hz}$			$f = 15 \text{ kHz}$			
		min	typ	max	min	typ	max	
$V_q/V_{q0} = -15 \text{ dB}$	V_q/V_{q0}	-11.0	- 9.0	- 7.0	-16.5	-13.5	-10.5	dB
$V_q/V_{q0} = -30 \text{ dB}$	V_q/V_{q0}	-20.5	-17.5	-14.5	-28.0	-25.0	-22.0	dB
$V_q/V_{q0} = -45 \text{ dB}$	V_q/V_{q0}	-30.0	-27.0	-24.0	-41.0	-37.0	-33.0	dB

Synchronous operation (measurement circuit 2)

$V_{i\text{rms}} = 300 \text{ mV}$, $f_i = 1.6 \text{ kHz}$, $V_8 = 0.5 \times V_2$, $V_{14} = 0.49 \times V_2$, S1 at physiology

		min	typ	max	
$V_{q1}/V_i = 0 \text{ dB}$	V_{q1}/V_{q2}	-1	0	1	dB
$V_{q1}/V_i = -15 \text{ dB}$	V_{q1}/V_{q2}	-1.5	0	1.5	dB
$V_{q1}/V_i = -30 \text{ dB}$	V_{q1}/V_{q2}	-2	0	2	dB
$V_{q1}/V_i = -45 \text{ dB}$	V_{q1}/V_{q2}	-2.5	0	2.5	dB
$V_{q1}/V_i = -60 \text{ dB}$	V_{q1}/V_{q2}	-3	0	3	dB

Measurement circuit 1 (mono operation)

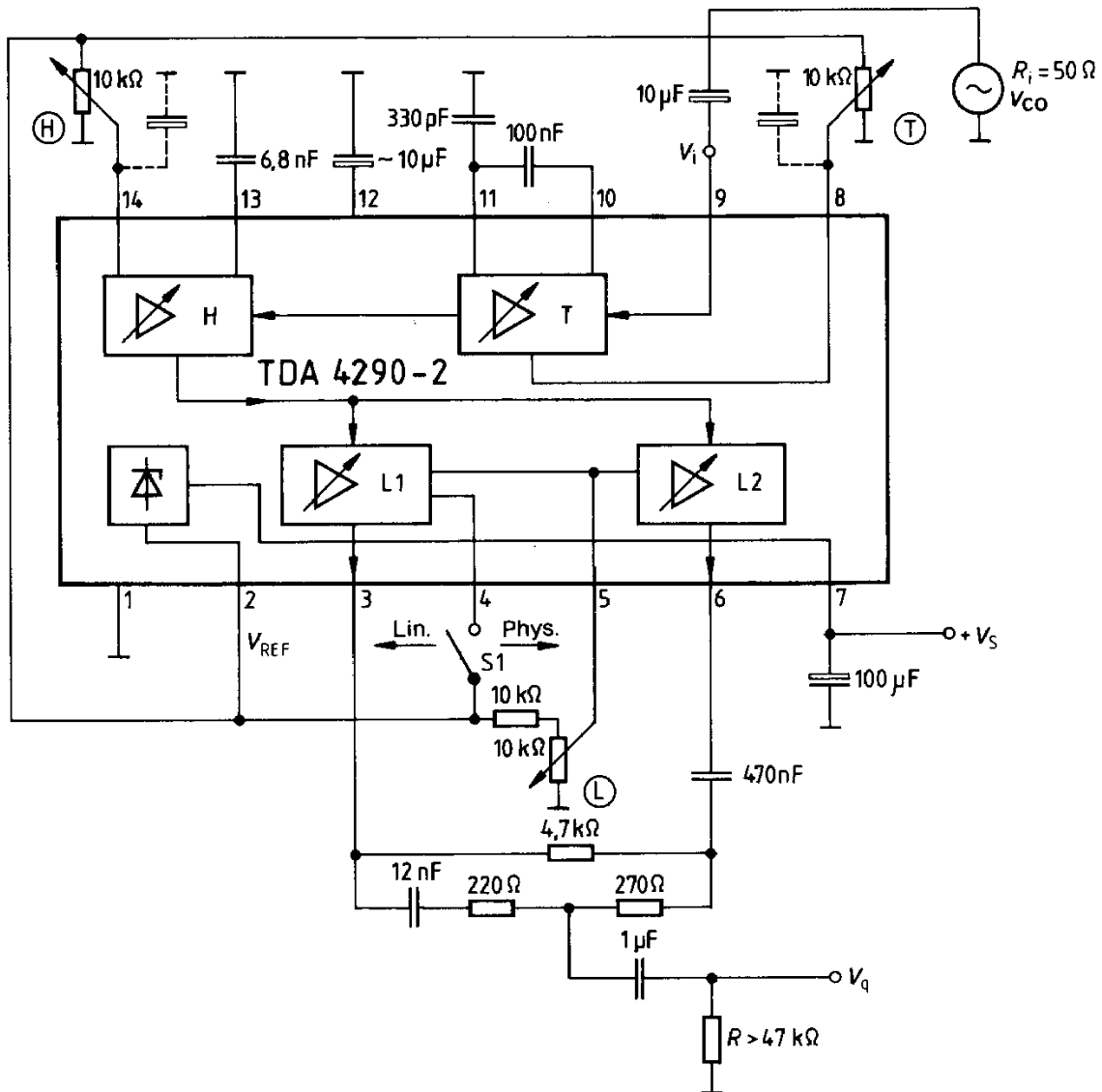

Measurement circuit 2 (stereo operation)

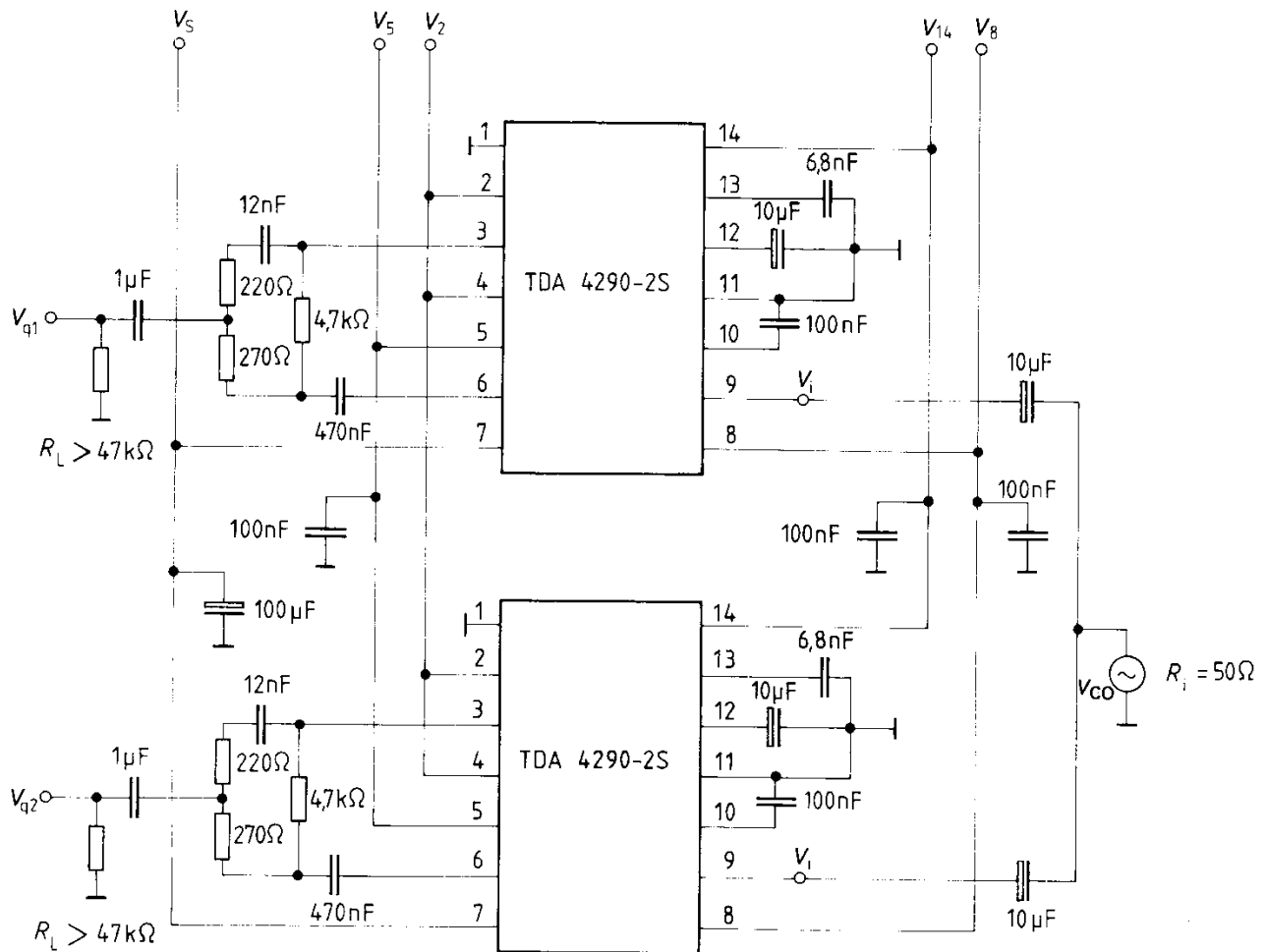

Physiological volume characteristic
(treble and bass control in linear position)
 $V_{i,rms} = 300\text{ mV}$, $f_i = 1.6\text{ kHz}$

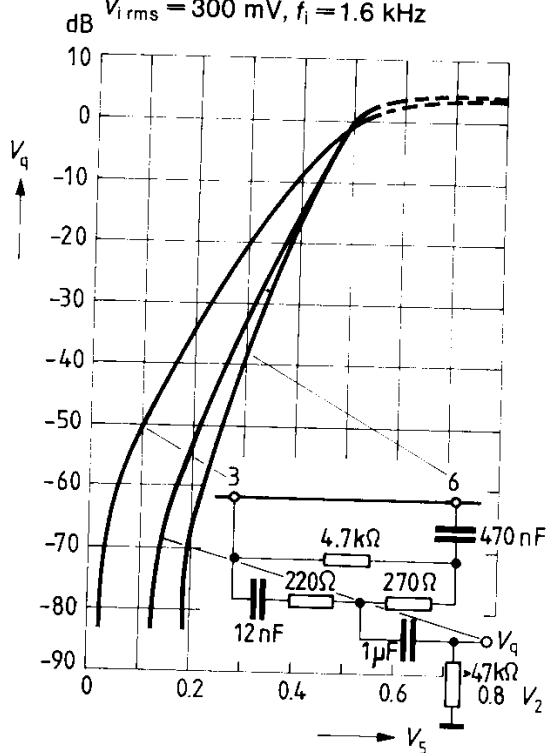

Treble control

S1 open; $V_{i,rms} = 300\text{ mV}$; volume = 0 dB
 $f_i = 20\text{ kHz}$

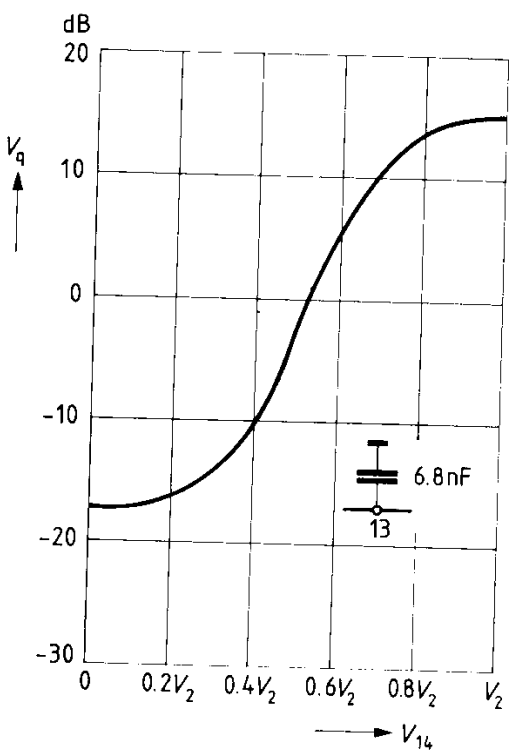

Bass control

S1 open; $V_{i,rms} = 300\text{ mV}$; volume = 0 dB
 $f_i = 20\text{ Hz}$

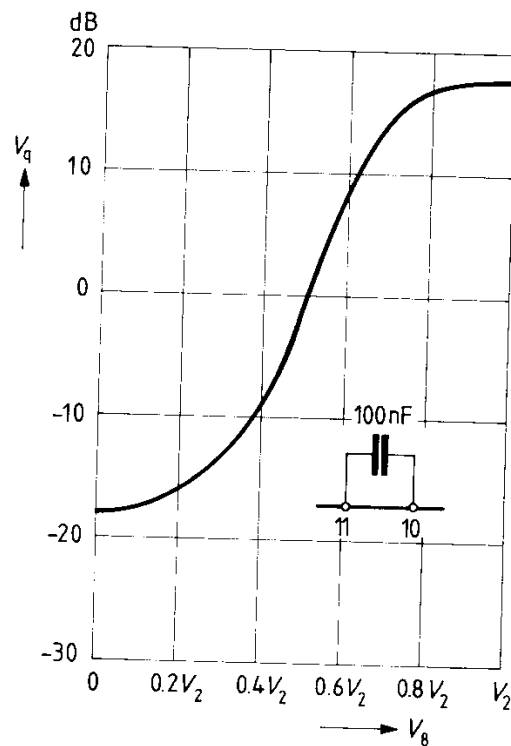

Bass and treble control

$V_{i,rms} = 300 \text{ mV} \triangleq 0 \text{ dB}$; S1 open

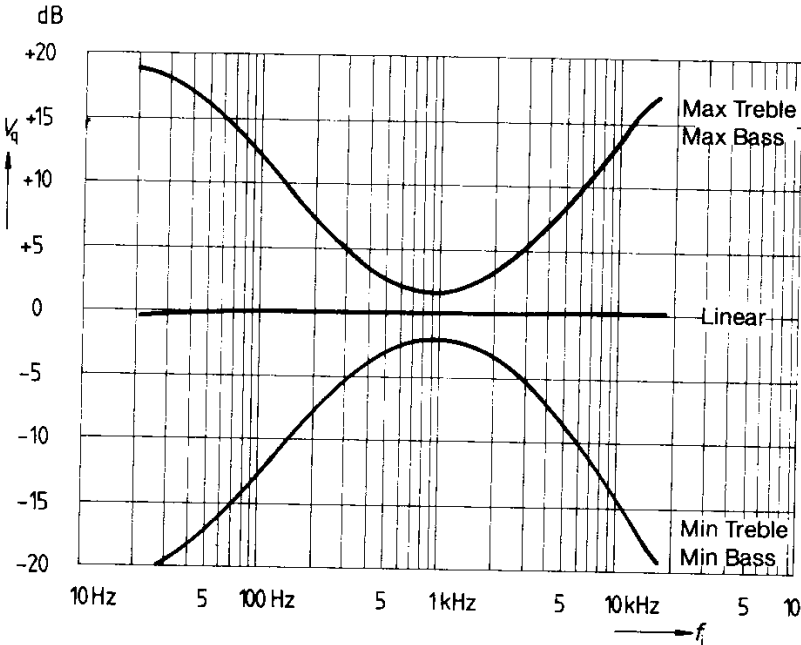

Bass and treble control

$V_{i,rms} = 300 \text{ mV} \triangleq 0 \text{ dB}$; S1 open

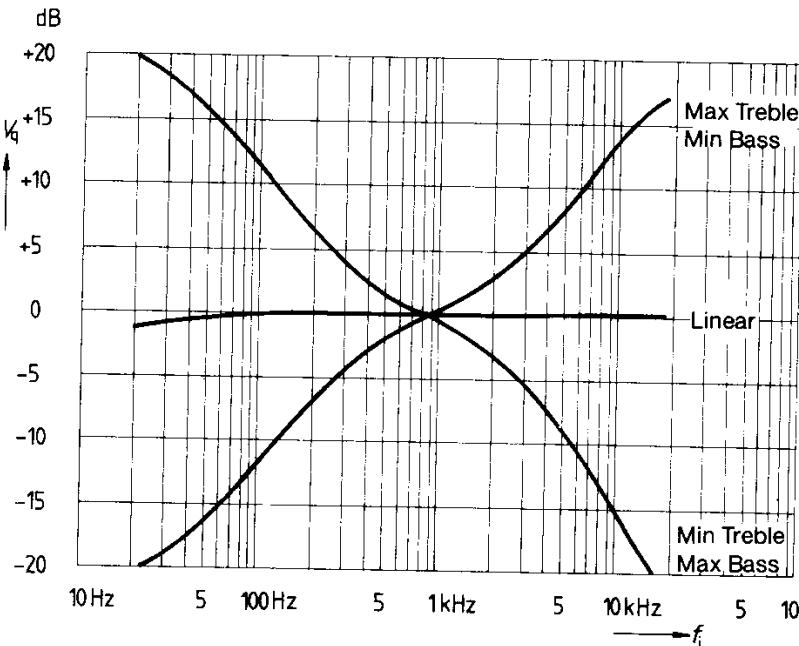

Physiological volume versus input frequency

S1 closed; $V_{i\text{rms}} = 300 \text{ mV} \triangleq 0 \text{ dB}$

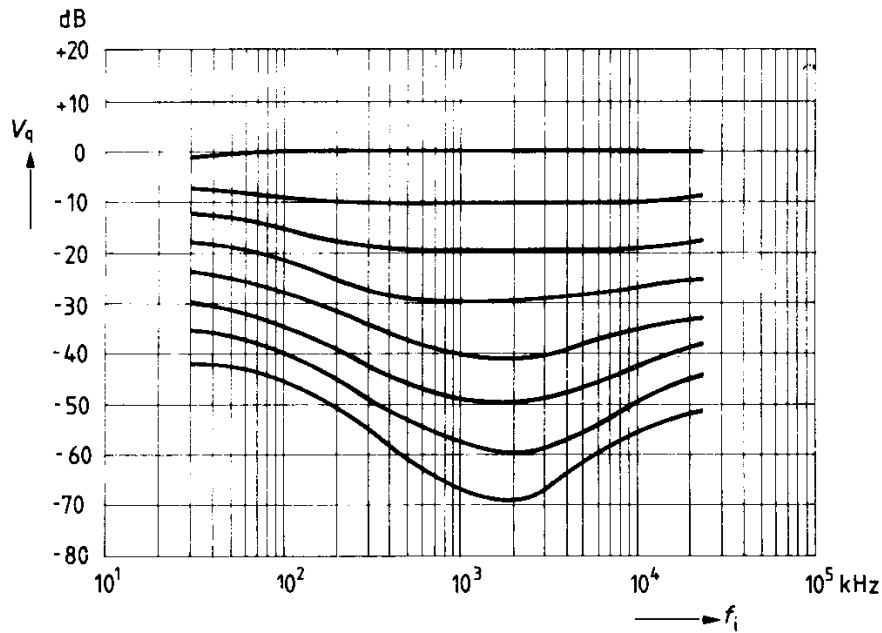

Disturbance voltage spacing

Bandwidth 30 Hz to 20 kHz; $V_{i\text{rms}} = 300 \text{ V} \triangleq 0 \text{ dB}$; $f_i = 1 \text{ kHz}$
S1 open; treble and bass control in linear position

