

Video-IF and Quasi Parallel Sound Processing

Description

The TDA4472 is an integrated bipolar circuit for video/sound IF (VIF/SIF) signal processing in TV/VCR and multimedia applications. The circuit processes all TV

video IF signals with negative modulation (e.g., B/G standard), and the FM/NICAM sound IF signals.

Features

- 5 V supply voltage; low power consumption
- Active carrier generation by FPLL principle (frequency-phase-locked-loop) for true synchronous demodulation
- Very linear video demodulation, good pulse response and excellent intermodulation figures
- VCO circuit operates at picture carrier frequency
- Alignment-free AFC without external reference circuit, polarity of the AFC curve is switchable
- VIF-AGC with peak sync. detection
- Tuner AGC with adjustable take over point
- Alignment-free quasi parallel sound (QPS) mixer for FM/NICAM sound IF signals
- Intercarrier output signal is gain controlled (necessary for digital sound processing)
- Separate SIF-AGC with average detection
- Two independent SIF inputs
- Package and relevant pinning is compatible with the multistandard version TDA4470, which simplifies the design of an universal IF module

Package: SDIP28, SO28

Ordering Information

Extended Type Number	Package	Remarks
TDA4472-MSD	SDIP28	
TDA4472-MFLG3	SO28	Delivery in taped form

Block Diagram

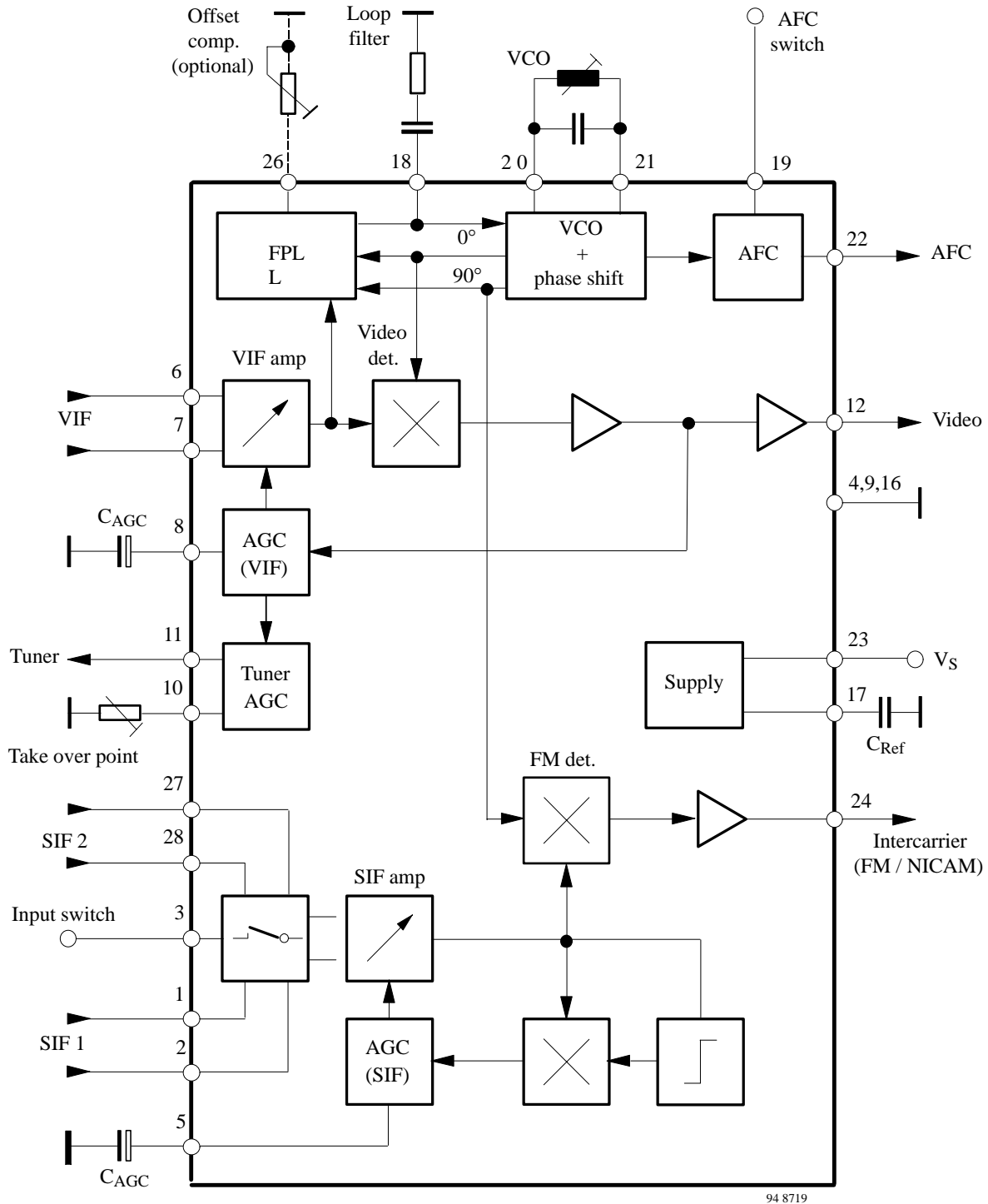

Figure 1. Block diagram

Circuit Description

Vision IF Amplifier

The video IF signal (VIF) is fed through a SAW filter to the differential input (Pin 6-7) of the VIF amplifier. This amplifier consists of three AC-coupled amplifier stages. Each differential amplifier is gain controlled by the automatic gain control (VIF-AGC). The output signal of the VIF amplifier is applied to the FPLL carrier generation and the video demodulator.

Tuner-and VIF-AGC

At Pin 8, the VIF-AGC charges/discharges the AGC capacitor to generate a control voltage for setting the gain of the VIF amplifier and tuner in order to keep the video output signal at a constant level. Therefore, in the case of all negative modulated signals (e.g., B/G standard) the sync. level of the demodulated video signal is the criterion for a fast charge/discharge of the AGC capacitor. The control voltage (AGC voltage at Pin 8) is transferred to an internal control signal, and is fed to the tuner AGC to generate the tuner AGC current at Pin 11 (open collector output). The take over point of the tuner AGC can be adjusted at Pin 10 by a potentiometer or an external dc voltage (from interface circuit or microprocessor).

FPLL, VCO and AFC

The FPLL circuit (frequency phase locked loop) consists of a frequency and phase detector to generate the control voltage for the VCO tuning. In the locked mode, the VCO is controlled by the phase detector and in unlocked mode, the frequency detector is superimposed. The VCO operates with an external resonance circuit (L and C parallel) and is controlled by internal varicaps. The VCO control voltage is also converted to a current and represents the AFC output signal at Pin 22.

A practicable VCO alignment of the external coil is the adjustment to zero AFC output current at Pin 22. At center frequency the AFC output current is equal to zero.

The optional potentiometer at Pin 26 allows an offset compensation of the VCO phase for improved sound quality (fine adjustment). Without a potentiometer (open circuit at Pin 26), this offset compensation is not active.

The oscillator signal passes a phase shifter and supplies the in-phase signal (0°) and the quadrature signal (90°) of the generated picture carrier.

Video Demodulation and Amplifier

The video IF signal, which is applied from the gain controlled IF amplifier, is multiplied with the inphase component of the VCO signal. The video demodulator is

designed for low distortion and large bandwidth. The demodulator output signal passes an integrated low pass filter for attenuation of the residual vision carrier and is fed to the video amplifier. The video amplifier is realized by an operational amplifier with internal feedback and 8 MHz bandwidth (−3 dB). An additional noise clipping is provided. The video signal is fed to VIF-AGC and to the video output buffer. This amplifier with a 6 dB gain offers easy adaption of the sound trap. For nominal video IF modulation the video output signal at Pin 12 is $2 V_{pp}$.

Sound IF Amplifier and SIF-AGC

The SIF amplifier is nearly identical with the 3-stage VIF amplifier. Only the first amplifier stage exists twice and is switchable by a control voltage at Pin 3. Therefore with a minimal external expense it is possible to switch between two different SAW filters. Both SIF inputs features excellent cross-talk attenuation and an input impedance which is independent from the switching condition.

The SIF-AGC is related to the average level of FM-carrier and controls the SIF amplifier to provide a constant SIF signal to the QPS mixer.

Quasi-Parallel-Sound (QPS) Mixer

The QPS mixer is realized by a multiplier. The SIF signal (FM or NICAM carrier) is converted to the intercarrier frequency by the regenerated picture carrier (quadrature signal) which is provided from the VCO. The intercarrier signal is fed via an output amplifier to Pin 24.

AFC Switch

The AFC output signal at Pin 22 can be controlled by a switching voltage at Pin 19. It is possible to switch off the AFC.

VCR Mode

For the VCR mode in a TV set (external video source selected), it is recommendable to switch off the IF circuit. With an external switching voltage at Pin 6 or 7, the IF amplifiers are switched off and all signal output levels at Pins 12 and 24 are according to the internal dc voltage.

Internal Voltage Stabilizer

The internal bandgap reference ensures constant performance independent of supply voltage and temperature.

Pin Description

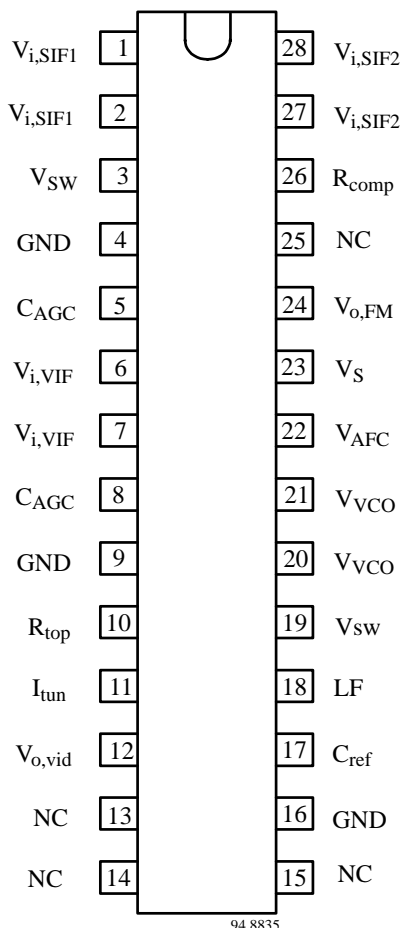

Figure 2. Pinning

Pin	Symbol	Function
1, 2	$V_{i, SIF1}$	SIF1 input (symmetrical)
3	V_{sw}	Input selector switch
4, 9, 16	GND	Ground
5	C_{AGC}	SIF-AGC (time constant)
6, 7	$V_{i, VIF}$	VIF input (symmetrical)
8	C_{AGC}	VIF-AGC (time constant)
10	R_{top}	Take over point, tuner AGC
11	I_{tun}	Tuner AGC output current
12	$V_{o, vid}$	Video output
13	NC	Not connected
14	NC	Not connected
15	NC	Not connected
17	C_{ref}	Internal reference voltage
18	LF	Loop filter
19	V_{sw}	AFC switch
20, 21	V_{VCO}	VCO circuit
22	V_{AFC}	AFC output
23	V_S	Supply voltage
24	$V_{O, FM}$	Intercarrier output
25	NC	Not connected
26	R_{comp}	Offset compensation
27, 28	$V_{i, SIF2}$	SIF 2 input (symmetrical)

Absolute Maximum Ratings

Reference point Pin 4 (9, 16), unless otherwise specified

Parameters	Symbol	Value	Unit
Supply voltage SDIP28 package SO28 package	Pin 23 V_S V_S	9.0 6.0	V V
Supply current	Pin 23 I_S	93	mA
Power dissipation SDIP28 package SO28 package	P P	840 560	mW mW
Output currents	Pins 12 and 24 I_{out}	5	mA
External voltages Pins 1, 2, 5 to 8, 10, 12, 17, 18 and 24, 26 to 28 Pins 20 and 21 Pin 11 Pins 3, 19 and 22	V_{ext}	+4.5 +3.5 +13.5 V_S	V V V V
Junction temperature	T_j	+125	°C
Storage temperature	T_{stg}	-25 to +125	°C
Electrostatic handling *) all pins	V_{ESD}	± 300	V

*) Equivalent to discharging a 200 pF capacitor through a 0 Ω resistor.

Operating Range

Parameters	Symbol	Value	Unit
Supply voltage range SDIP28 package SO28 package	Pin 23 V_S V_S	4.5 to 9.0 4.5 to 6.0	V V
Ambient temperature	T_{amb}	-10 to +85	°C

Thermal Resistance

Parameters	Symbol	Maximum	Unit
Junction ambient, when soldered to PCB SDIP28 package SO28 package	R_{thJA} R_{thJA}	55 75	K/W K/W

Electrical Characteristics

$V_S = +5\text{ V}$, $T_{\text{amb}} = +25^\circ\text{C}$; reference point Pin 4 (9, 16), unless otherwise specified

Parameters	Test Conditions / Pins	Symbol	Min.	Typ.	Max.	Unit
DC-supply Pin 23						
Supply voltage – SDIP28 – SO28		V_S	4.5	5.0	9.0	V
		V_S	4.5	5.0	5.5	V
Supply current		I_S		85	93	mA
VIF-input Pin 6-7						
Input sensitivity, (RMS value)	For FPLL locked	v_{in}		80	120	μV_{RMS}
Input impedance	See note 1	R_{in}		1.2		k Ω
Input capacitance	See note 1	C_{in}		2		pF
VIF-AGC Pins 8 and 15						
IF gain control range		G_v	60	65		dB
AGC capacitor	Pin 8	C_{AGC}		2.2		μF
Black level capacitor	Pin 15	C_{BL}		100		nF
Switching voltage: VCR mode	See note 2	V_{sw}		4.0		V
Switching current: VCR mode	See note 2	I_{sw}		50		μA
Tuner-AGC Pins 10 and 11 see note 3						
Available tuner-AGC current		I_{tun}	1	2	4	mA
Allowable output voltage		V_{11}	0.3		13.5	V
IF slip – tuner AGC	Current I_{tun} : 10 to 90%	ΔG_{IF}		8	10	dB
IF input signal for minimum take over point	$R_{\text{top}} = 10\text{ k}\Omega$ ($V_{\text{top}} = 4.5\text{ V}$)	v_{in}			4	mV
IF input signal for maximum take over point	$R_{\text{top}} = 0$, ($V_{\text{top}} = 0.8\text{ V}$)	v_{in}	40			mV
Variation of the take over point by temperature	$\Delta T_{\text{amb}} = 55^\circ\text{C}$ VIF-AGC: $G_v = 46\text{ dB}$	Δv_{in}		2	3	dB
FPLL and VCO Pins 18, 20, 21 and 26 see note 4						
Max. oscillator frequency	For carrier generation	f_{vco}	70			MHz
Vision carrier capture range	$f_{\text{vco}} = 38.9\text{ MHz}$, $C_{\text{vco}} = 8.2\text{ pF}$	Δf_{cap}	± 1.5	± 2		MHz
Oscillator drift (free running) as function of temperature	See note 5, $\Delta T_{\text{amb}} = 55^\circ\text{C}$, $C_{\text{vco}} = 8.2\text{ pF}$, $f_{\text{vco}} = 38.9\text{ MHz}$	$\Delta f/\Delta T$			-0.3	%
Video output Pin 12						
Output current – source – sink		$\pm I_{12}$			5 3	mA mA
			2			
Output resistance	See note 1	R_{out}			100	Ω
Video output signal	Peak-to-peak value	$v_{\text{o,vid}}$	1.8	2.0	2.2	V _{pp}
Difference of the video signals	Between B/G and L	$\Delta v_{\text{o,vid}}$			10	%
Sync. level		V_{sync}		1.2		V
Zero carrier level for neg. modulation, ultra white level	$V_{13} = V_S$ $V_8 = 3\text{ V}$	V_{DC}		3.4		V
Zero carrier level for pos. modulation, ultra black level	$V_{13} = 0$ $V_8 = 3\text{ V}$	V_{DC}		1.15		V
Supply voltage influence on the ultra white and ultra black level		$\Delta V/v$		1		%/V
Video bandwidth (-3 dB)	$R_L \geq 1\text{ k}\Omega$, $C_L \leq 50\text{ pF}$	B	6	8		MHz

Parameters	Test Conditions / Pins	Symbol	Min.	Typ.	Max.	Unit
Video frequency response over the AGC range		ΔB			2.0	dB
Differential gain error		DG		2	5	%
Differential phase error		DP		2	5	deg
Intermodulation 1.07 MHz	See note 6	α_{IM}	52	60		dB
Video signal to noise ratio	Weighted, CCIR-567	S/N	56	60		dB
Residual vision carrier fundamental wave 38.9 MHz and second harmonic 77.8 MHz		v_{res1}		2	10	mV
Lower limiting level	Below sync level	ΔV_{lim1}		400		mV
Upper limiting level	Above ultra white level	ΔV_{lim2}		600		mV
Ripple rejection	See note 1, Pin 23/Pin 12	RR	35			dB
AFC output Pin 22						
Control slope		$\Delta I/\Delta f$		0.7		$\mu A/kHz$
Frequency drift by temperature	Related to the picture carrier frequency			0.25	0.6	%
Output voltage – upper limit – lower limit		V_{AFC}	$V_S-0.4$		0.4	V V
Output current		I_{AFC}		± 0.2		mA
AFC switch Pin 19						
Control voltage: AFC “off” AFC “on”	See note 7	V_{SW}	0 3.5		0.8 V_S	V V
Switching current		I_{SW}		± 100		μA
SIF inputs Pin 1-2, 27-28						
Input sensitivity (RMS value)	Output signal at Pin 24/25: -3 dB	v_{in}		80	120	μV_{RMS}
Input impedance	See note 1	R_{in}		1.2		k Ω
Input capacitance	See note 1	C_{in}		2		pF
SIF-AGC Pin 5						
IF gain control range		G_v	60	65		dB
AGC capacitor		C_{AGC}		10		μF
Intercarrier output-FM Pin 24 see note 8						
DC output voltage		V_{DC}		2		V
Output resistance	See note 1	R_{out}		150		Ω
Sound IF output voltage (5.5 MHz output voltage)	$v_{in} = 10$ mV	v_{out}	180	250	350	mV $_{RMS}$
Weighted signal to noise ratio: (CCIR 468)	Ref. signal: $v_{in} = 10$ mV; FM dev. = ± 27 kHz $f_{mod} = 1$ kHz; tested with the double FM demod. U2860B; B/G modulated VIF signal Black screen: Channel 1/2 Grid pattern: Channel 1/2 Grey screen 50%: Channel 1/2	S/N S/N S/N		60/58 54/52 60/57		dB dB dB
Ripple rejection	See note 1, Pin 23/Pin 24	RR	35			dB
SIF input selector switch Pin 3						

Parameters	Test Conditions / Pins	Symbol	Min.	Typ.	Max.	Unit
Control voltage: – input 1 active – input 2 active	See note 9	V_{SW}	2.0 0		V_S 0.8	V V
Switching current		I_{SW}		± 100		μA

Notes

- 1.) This parameter is given as an application information and not tested during production.
- 2.) In VCR mode the VIF- and SIF path is switched off.
- 3.) Adjustment of turn over point (delayed tuner AGC) with external resistor R_{top} or external voltage V_{top} possible.
- 4.) Resonance circuit of VCO ($f_0 = 38.9$ MHz): $C_{VCO} = 8.2 - 10$ pF,
Coil L_{VCO} with unloaded Q-factor $Q_0 \geq 60$ for an oscillator voltage ≥ 100 mV_{RMS} at Pin 20 – 21
(e.g. TOKO coil 7 KM, 292 XNS - 4051Z)
- 5.) The oscillator drift is related to the picture carrier frequency, at external temperature-compensated LC circuit.
- 6.) $\alpha (1.07) = 20 \log (4.43 \text{ MHz component} / 1.07 \text{ MHz component})$; $\alpha (1.07)$ value related to black-white signal input signal conditions: picture carrier = 0 dB, colour carrier = -6 dB, sound carrier = -24 dB
- 7.) Without control voltage at Pin 19 "AFC on" is automatically selected.
- 8.) Picture carrier PC = 38.9 MHz; sound carrier $SC_1 = 33.4$ MHz, $SC_2 = 33.16$ MHz;
PC/ SC_1 = 13 dB; PC/ SC_2 = 20 dB; PC unmodulated (equivalent to sync. peak level).
- 9.) Without control voltage at Pin 3 the SIF input 1 is automatically selected.

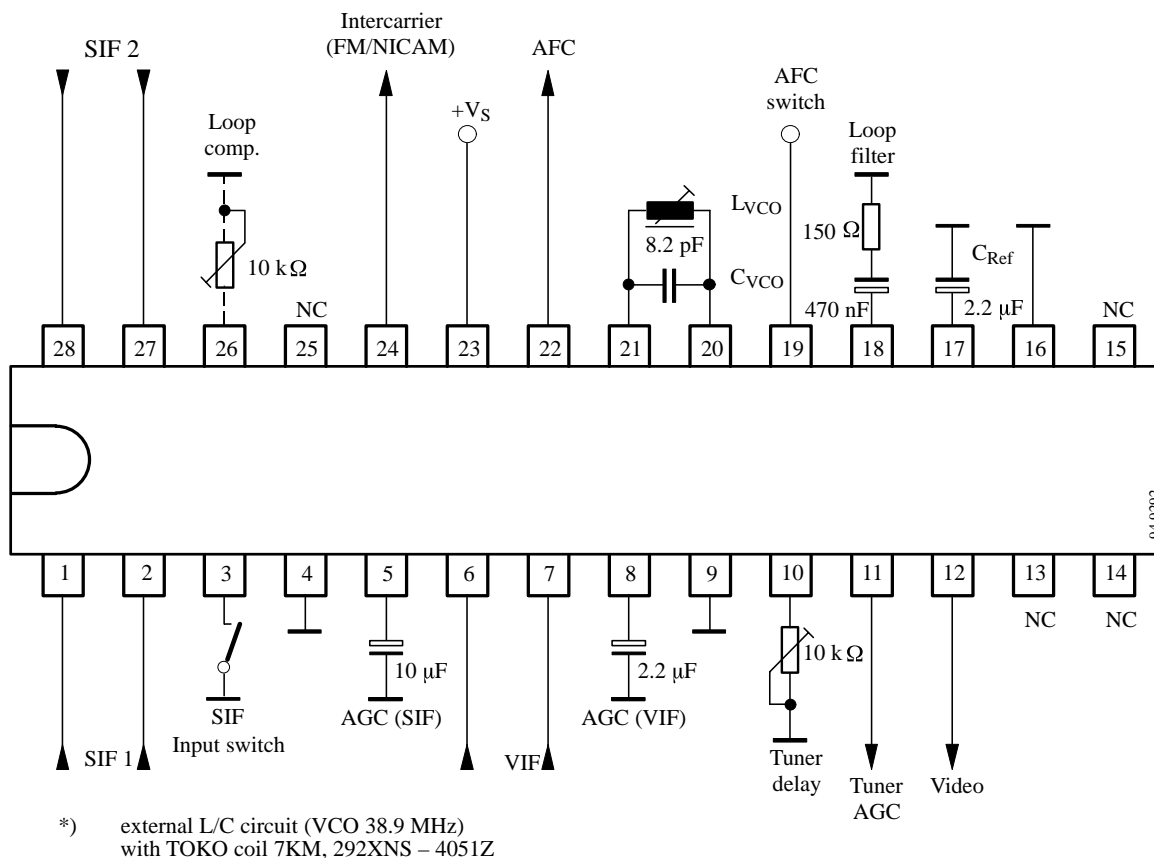

Figure 3. Test circuit

Internal Pin Configuration

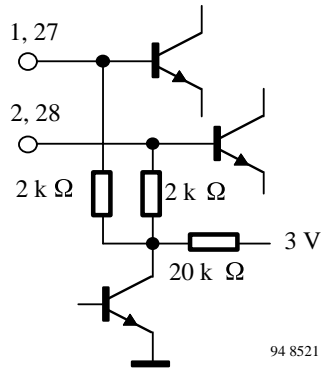

Figure 5. Sound IF inputs (Pin 1-2, 27-28)

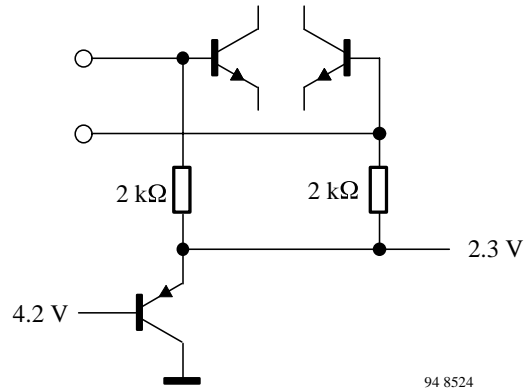

Figure 8. Video IF input (Pin 6-7)

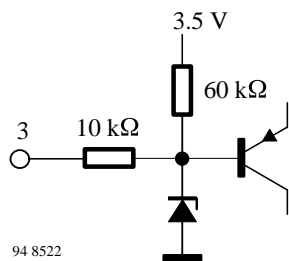

Figure 6. Input selector switch (Pin 3)

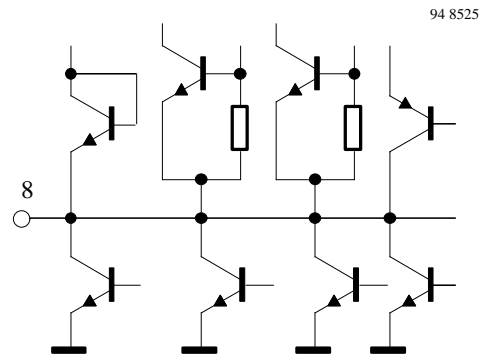

Figure 9. VIF-AGC time constant (Pin 8)

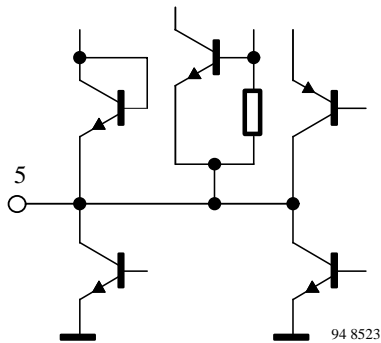

Figure 7. SIF-AGC time constant (Pin 5)

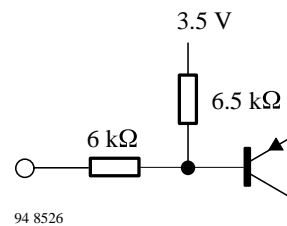

Figure 10. Tuner AGC – take over point (Pin 10)

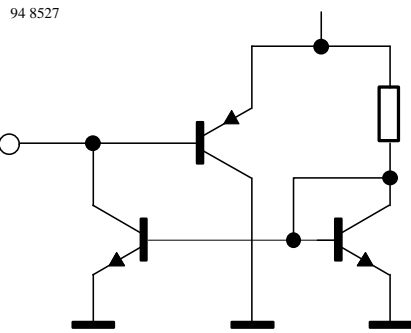

Figure 11. Tuner AGC – output (Pin 11)

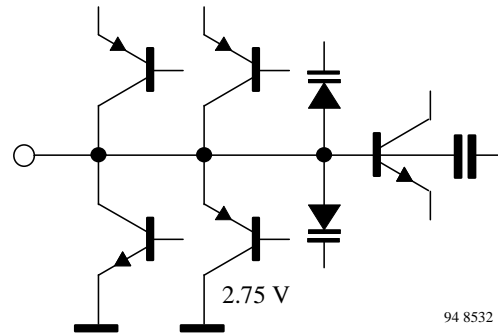

Figure 14. Loop filter (Pin 18)

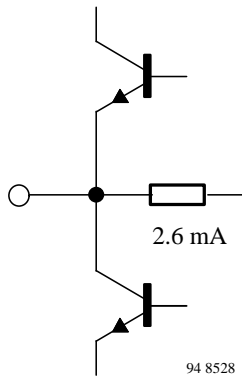

Figure 12. Video output (Pin 12)

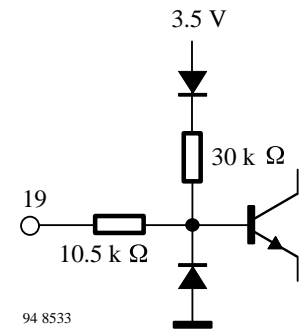

Figure 15. AFC switch (Pin 19)

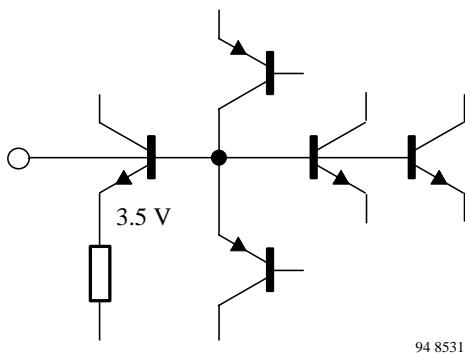

Figure 13. Internal reference voltage (Pin 17)

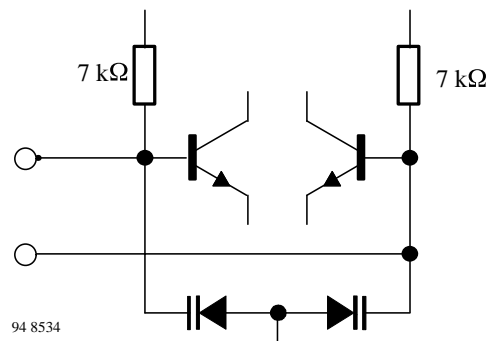

Figure 16. VCO (Pin 20-21)

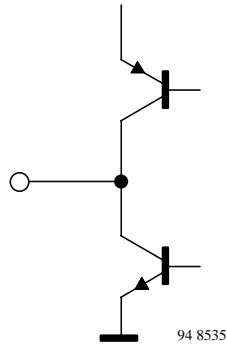

Figure 17. AFC output (Pin 22)

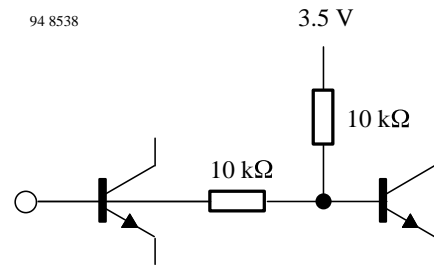

Figure 19. VCO offset compensation (Pin 26)

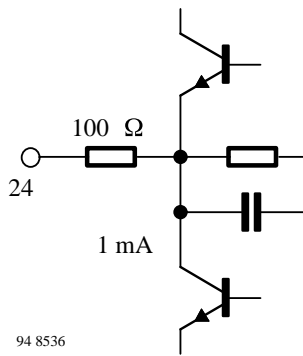
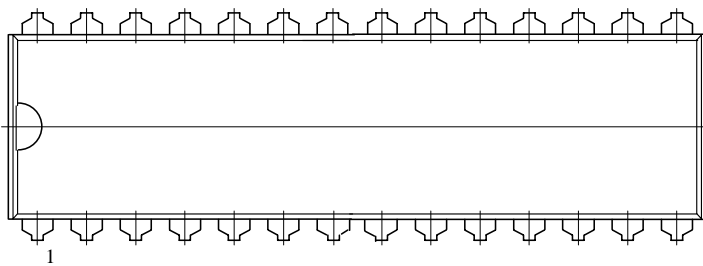
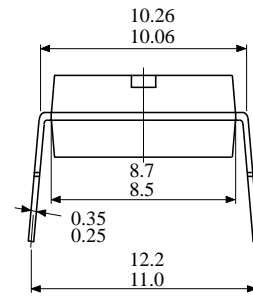
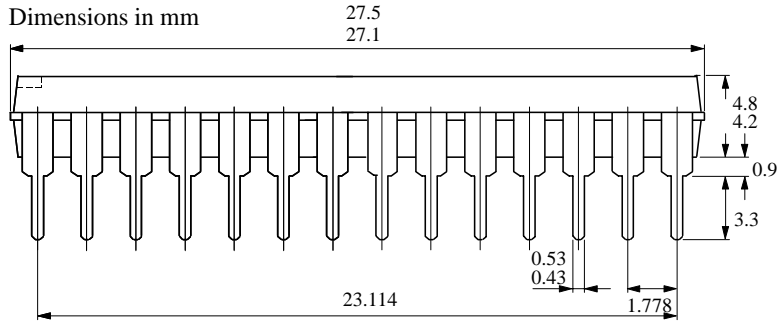

Figure 18. Intercarrier output (Pin 24)

Dimensions in mm

Package SDIP28

Dimensions in mm



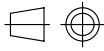

technical drawings
according to DIN
specifications

13044

Package SO28

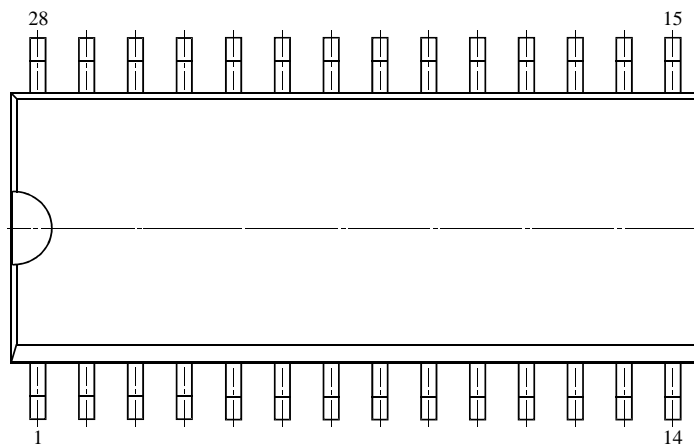
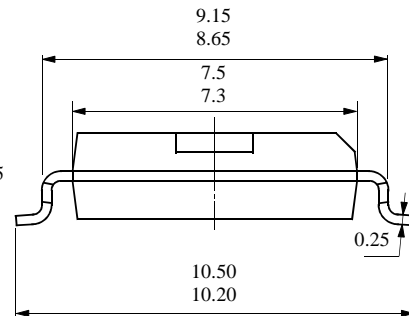
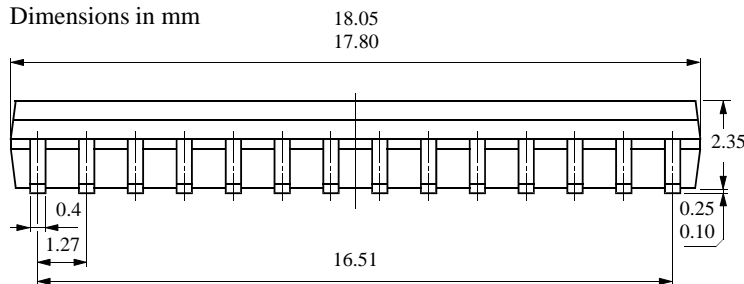
Dimensions in mm



technical drawings
according to DIN
specifications

13033

Ozone Depleting Substances Policy Statement

It is the policy of **TEMIC Semiconductor GmbH** to

1. Meet all present and future national and international statutory requirements.
2. Regularly and continuously improve the performance of our products, processes, distribution and operating systems with respect to their impact on the health and safety of our employees and the public, as well as their impact on the environment.

It is particular concern to control or eliminate releases of those substances into the atmosphere which are known as ozone depleting substances (ODSs).

The Montreal Protocol (1987) and its London Amendments (1990) intend to severely restrict the use of ODSs and forbid their use within the next ten years. Various national and international initiatives are pressing for an earlier ban on these substances.

TEMIC Semiconductor GmbH has been able to use its policy of continuous improvements to eliminate the use of ODSs listed in the following documents.

1. Annex A, B and list of transitional substances of the Montreal Protocol and the London Amendments respectively
2. Class I and II ozone depleting substances in the Clean Air Act Amendments of 1990 by the Environmental Protection Agency (EPA) in the USA
3. Council Decision 88/540/EEC and 91/690/EEC Annex A, B and C (transitional substances) respectively.

TEMIC Semiconductor GmbH can certify that our semiconductors are not manufactured with ozone depleting substances and do not contain such substances.

We reserve the right to make changes to improve technical design and may do so without further notice.

Parameters can vary in different applications. All operating parameters must be validated for each customer application by the customer. Should the buyer use TEMIC Semiconductors products for any unintended or unauthorized application, the buyer shall indemnify TEMIC Semiconductors against all claims, costs, damages, and expenses, arising out of, directly or indirectly, any claim of personal damage, injury or death associated with such unintended or unauthorized use.

TEMIC Semiconductor GmbH, P.O.B. 3535, D-74025 Heilbronn, Germany
Telephone: 49 (0)7131 67 2594, Fax number: 49 (0)7131 67 2423