

2.6W, Ultra-Low EMI, Filterless, Mono Class D Audio Power Amplifier with E²S

General Description

The LM48312 is a single supply, high efficiency, mono, 2.6W, filterless switching audio amplifier. The LM48312 features National's Enhanced Emissions Suppression (E²S) system, that features a unique patented ultra low EMI, spread spectrum, PWM architecture, that significantly reduces RF emissions while preserving audio quality and efficiency. The E²S system improves battery life, reduces external component count, board area consumption, and system cost, simplifying design.

The LM48312 is designed to meet the demands of portable multimedia devices. Operating from a single 5V supply, the device is capable of delivering 2.6W of continuous output power to a 4Ω load with less than 10% THD+N. Flexible power supply requirements allow operation from 2.4V to 5.5V. The LM48312 features both a spread spectrum modulation scheme, and an advanced, patented edge rate control (ERC) architecture that significantly reduces emissions, while maintaining high quality audio reproduction (THD+N = 0.03%) and high efficiency ($\eta = 88\%$).

The LM48312 features high efficiency compared to conventional Class AB amplifiers, and other low EMI Class D amplifiers. When driving an 8Ω speaker from a 5V supply, the device operates with 88% efficiency at $P_O = 1W$. The LM48312 features five gain settings, selected through a single logic input, further reducing solution size. A low power shutdown mode reduces supply current consumption to 0.01μA.

Advanced output short circuit protection with auto-recovery prevents the device from being damaged during fault conditions. Superior click and pop suppression eliminates audible transients on power-up/down and during shutdown.

Key Specifications

■ Efficiency at 3.6V, 400mW into 8Ω	84% (typ)
■ Efficiency at 5V, 1W into 8Ω	88% (typ)
■ Quiescent Power Supply Current at 5V	3.1mA
■ Power Output at $V_{DD} = 5V, R_L = 4\Omega$	
THD+N ≤ 10%	2.6W (typ)
THD+N ≤ 1%	2.1W (typ)
■ Power Output at $V_{DD} = 5V, R_L = 8\Omega$	
THD+N ≤ 10%	1.6W (typ)
THD+N ≤ 1%	1.3W (typ)
■ Shutdown current	0.01μA (typ)

Features

- Passes FCC Class B Radiated Emissions with 20 inches of cable
- E²S System Reduces EMI while Preserving Audio Quality and Efficiency
- Output Short Circuit Protection with Auto-Recovery
- No output filter required
- Improved Audio Quality
- Minimum external components
- Five Logic Selectable Gain Settings (0, 3, 6, 9, 12dB)
- Low Power Shutdown Mode
- Click and Pop suppression
- Available in space-saving microSMD package

Applications

- Mobile phones
- PDAs
- Laptops

LM48312 2.6W, Ultra-Low EMI, Filterless, Mono Class D Audio Power Amplifier with E²S

Typical Application

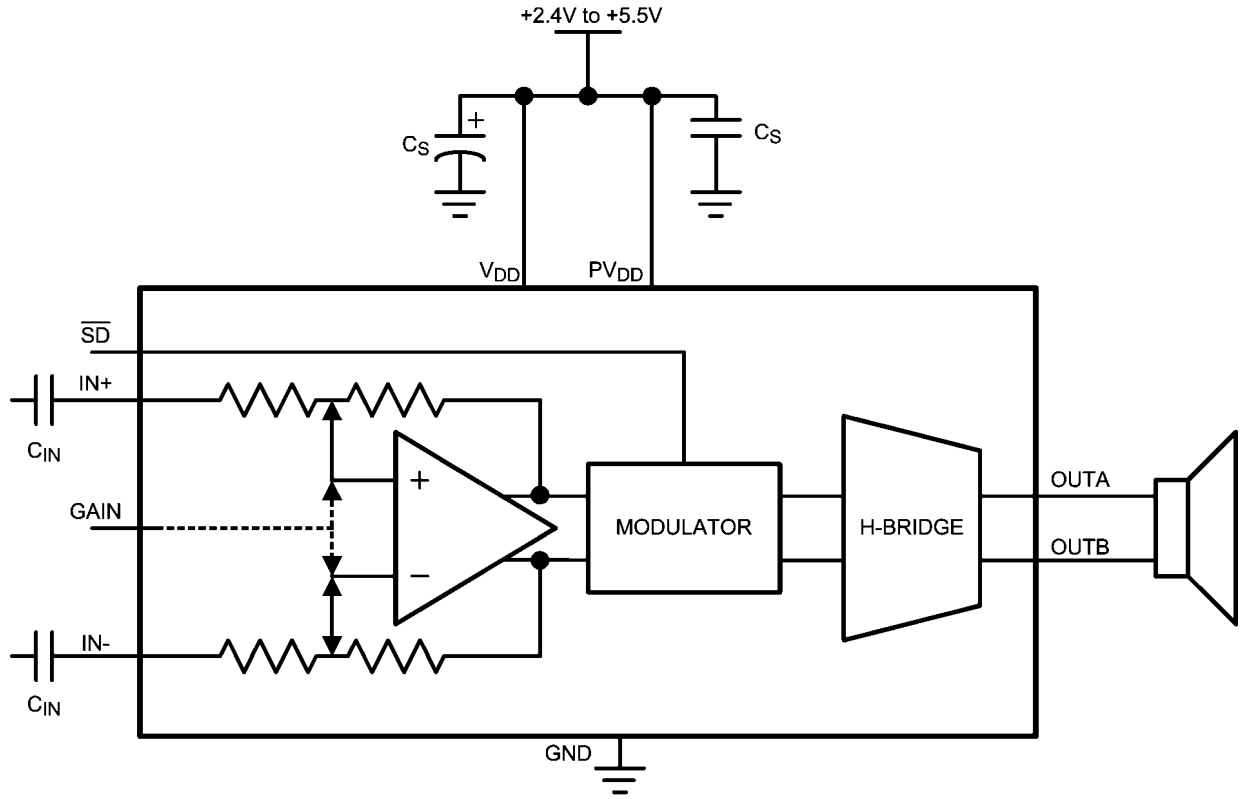

30110731

FIGURE 1. Typical Audio Amplifier Application Circuit

Connection Diagrams

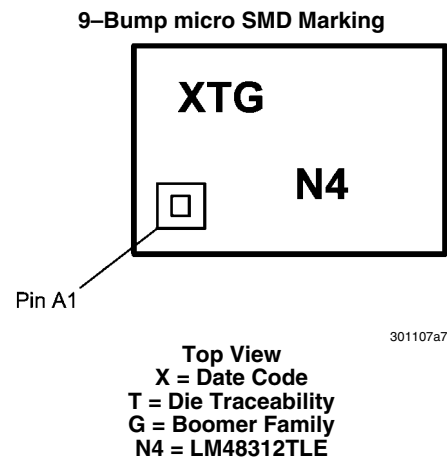
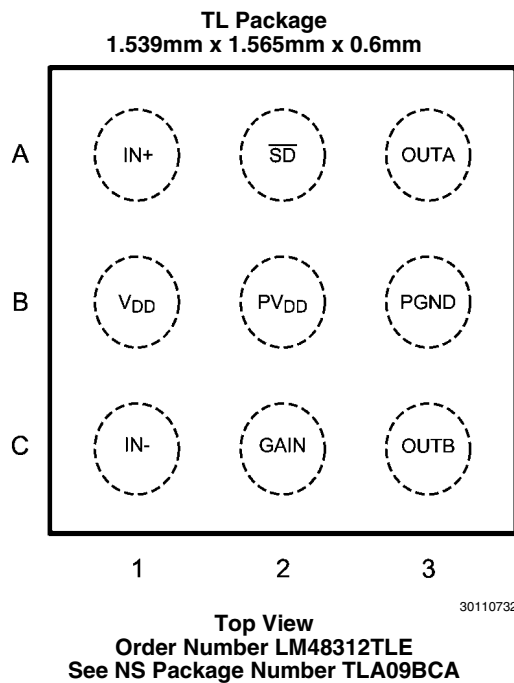

Ordering Information

Order Number	Package	Package DWG #	Transport Media	MSL Level	Green Status
LM48312TLE	9 Bump micro SMD	TLA09BCA	250 units on tape and reel	1	RoHS & no Sb/Br
LM48312TLX	9 Bump micro SMD	TLA09BCA	3000 units on tape and reel	1	RoHS & no Sb/Br

Pin Descriptions

TABLE 1. Bump Description

Pin	Name	Description
A1	IN+	Non-Inverting Input
A2	\overline{SD}	Active Low Shutdown Input. Connect to V_{DD} for normal operation.
A3	OUTA	Non-Inverting Output
B1	V_{DD}	Power Supply
B2	PV_{DD}	H-Bridge Power Supply
B3	PGND	Ground
C1	IN-	Inverting Input
C2	GAIN	Gain Select: GAIN = FLOAT: $A_V = 0\text{dB}$ GAIN = V_{DD} : $A_V = 3\text{dB}$ GAIN = GND: $A_V = 6\text{dB}$ GAIN = $20\text{k}\Omega$ to GND = 9dB GAIN = $20\text{k}\Omega$ to V_{DD} = 12dB
C3	OUTB	Inverting Output

Absolute Maximum Ratings (Note 1, Note

2)

If Military/Aerospace specified devices are required, please contact the National Semiconductor Sales Office/ Distributors for availability and specifications.

Supply Voltage	6.0V
Storage Temperature	-65°C to +150°C
Input Voltage	-0.3V to $V_{DD} + 0.3V$
Power Dissipation (Note 3)	Internally Limited
ESD Rating (Note 4)	2000V
ESD Rating (Note 5)	200V

Junction Temperature	150°C
Thermal Resistance	
θ_{JA}	70°C/W
Soldering Information	
	See AN-1112 "Micro SMD Wafer Level Chip Scale Package."

Operating Ratings (Note 1, Note 2)

Temperature Range		
$T_{MIN} \leq T_A \leq T_{MAX}$		$-40^\circ\text{C} \leq T_A \leq +85^\circ\text{C}$
Supply Voltage (V_{DD}, PV_{DD})		$2.4V \leq V_{DD} \leq 5.5V$

Electrical Characteristics $V_{DD} = PV_{DD} = 5V$ (Note 2, Note 8)

The following specifications apply for $A_V = 6\text{dB}$, $R_L = 8\Omega$, $f = 1\text{kHz}$, unless otherwise specified. Limits apply for $T_A = 25^\circ\text{C}$.

Symbol	Parameter	Conditions	LM48312			Units (Limits)
			Min (Note 7)	Typ (Note 6)	Max (Note 7)	
V_{DD}	Supply Voltage Range		2.4		5.5	V
I_{DD}	Quiescent Power Supply Current	$V_{IN} = 0, R_L = 8\Omega$		2.6	3.3	mA
		$V_{DD} = 3.3V$ $V_{DD} = 5V$		3.1	3.9	mA
I_{SD}	Shutdown Current	Shutdown enabled		0.01	1.0	μA
V_{OS}	Differential Output Offset Voltage	$V_{IN} = 0$	-48	10	48	mV
V_{IH}	Logic Input High Voltage		1.4			V
V_{IL}	Logic Input Low Voltage				0.4	V
T_{WU}	Wake Up Time			7.5		ms
f_{SW}	Switching Frequency			300±30		kHz
A_V	Gain	GAIN = FLOAT	-0.5	0	0.5	dB
		GAIN = V_{DD}	2.5	3	3.5	dB
		GAIN = GND	5.5	6	6.5	dB
		GAIN = 20k Ω to GND	8.5	9	9.5	dB
		GAIN = 20k Ω to V_{DD}	11.5	12	12.5	dB
R_{IN}	Input Resistance	$A_V = 0\text{dB}$		56		k Ω
		$A_V = 3\text{dB}$		49		k Ω
		$A_V = 6\text{dB}$		42		k Ω
		$A_V = 9\text{dB}$		35		k Ω
		$A_V = 12\text{dB}$	20	27		k Ω

Symbol	Parameter	Conditions	LM48312			Units (Limits)
			Min (Note 7)	Typ (Note 6)	Max (Note 7)	
P _O	Output Power	R _L = 4Ω, THD = 10% f = 1kHz, 22kHz BW V _{DD} = 5V V _{DD} = 3.3V V _{DD} = 2.5V		2.6 1.1 580		W W mW
		R _L = 8Ω, THD = 10% f = 1kHz, 22kHz BW V _{DD} = 5V V _{DD} = 3.3V V _{DD} = 2.5V		1.6 660 354		W mW mW
		R _L = 4Ω, THD = 1% f = 1kHz, 22kHz BW V _{DD} = 5V V _{DD} = 3.3V V _{DD} = 2.5V		2.1 900 460		W mW mW
		R _L = 8Ω, THD = 1% f = 1kHz, 22kHz BW V _{DD} = 5V V _{DD} = 3.3V V _{DD} = 2.5V	1.1 450	1.3 530 286		W (min) mW mW
THD+N	Total Harmonic Distortion + Noise	P _O = 200mW, R _L = 8Ω, f = 1kHz		0.027		%
		P _O = 100mW, R _L = 8Ω, f = 1kHz		0.03		%
PSRR	Power Supply Rejection Ratio	V _{RIPPLE} = 200mV _{P-P} Sine, Inputs AC GND, A _V = 0dB, C _{IN} = 1μF f _{RIPPLE} = 217Hz f _{RIPPLE} = 1kHz		71 70		dB dB
CMRR	Common Mode Rejection Ratio	V _{RIPPLE} = 1V _{P-P} , f _{RIPPLE} = 217Hz A _V = 0dB		65		dB
η	Efficiency	V _{DD} = 5V, P _{OUT} = 1W		88		%
		V _{DD} = 3.3V, P _{OUT} = 400mW		85		%
SNR	Signal to Noise Ratio	P _O = 1W		95		dB
CMVR	Common Mode Input Voltage Range		0	V _{DD} - 0.25		V
ε _{OS}	Output Noise	Un-weighted, A _V = 0dB		69		μV
		A-weighted, A _V = 0dB		48		μV

Note 1: "Absolute Maximum Ratings" indicate limits beyond which damage to the device may occur, including inoperability and degradation of device reliability and/or performance. Functional operation of the device and/or non-degradation at the *Absolute Maximum Ratings* or other conditions beyond those indicated in the *Recommended Operating Conditions* is not implied. The *Recommended Operating Conditions* indicate conditions at which the device is functional and the device should not be operated beyond such conditions. All voltages are measured with respect to the ground pin, unless otherwise specified.

Note 2: The *Electrical Characteristics* tables list guaranteed specifications under the listed *Recommended Operating Conditions* except as otherwise modified or specified by the *Electrical Characteristics Conditions* and/or Notes. Typical specifications are estimations only and are not guaranteed.

Note 3: The maximum power dissipation must be derated at elevated temperatures and is dictated by T_{JMAX} , θ_{JA} , and the ambient temperature, T_A . The maximum allowable power dissipation is $P_{DMAX} = (T_{JMAX} - T_A) / \theta_{JA}$ or the number given in *Absolute Maximum Ratings*, whichever is lower.

Note 4: Human body model, applicable std. JESD22-A114C.

Note 5: Machine model, applicable std. JESD22-A115-A.

Note 6: Typical values represent most likely parametric norms at $T_A = +25^\circ\text{C}$, and at the *Recommended Operation Conditions* at the time of product characterization and are not guaranteed.

Note 7: Datasheet min/max specification limits are guaranteed by test or statistical analysis.

Note 8: R_L is a resistive load in series with two inductors to simulate an actual speaker load. For $R_L = 8\Omega$, the load is $15\mu\text{H} + 8\Omega + 15\mu\text{H}$. For $R_L = 4\Omega$, the load is $15\mu\text{H} + 4\Omega + 15\mu\text{H}$.

Test Circuits

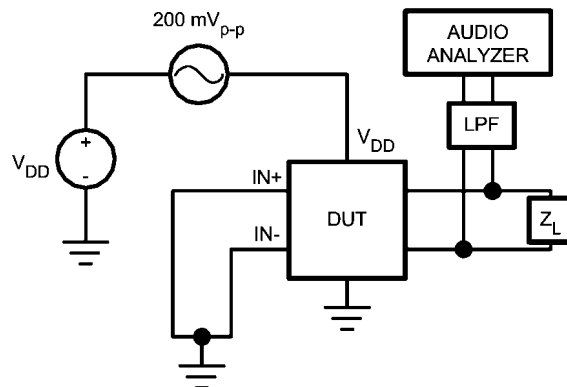

FIGURE 2. PSRR Test Circuit

30110728

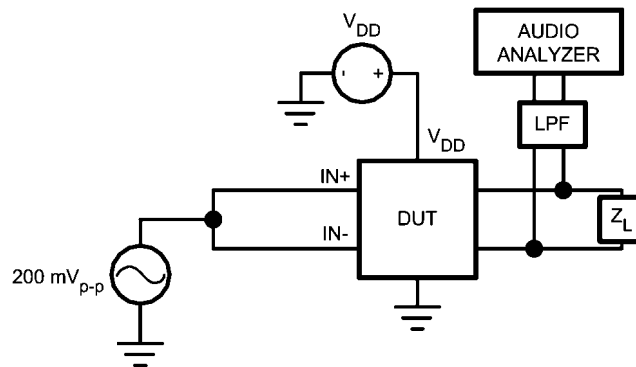
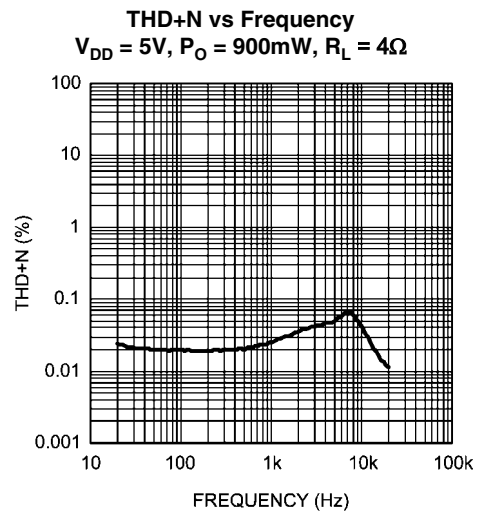
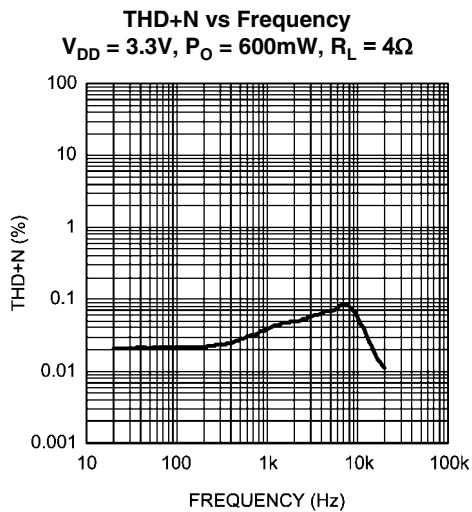
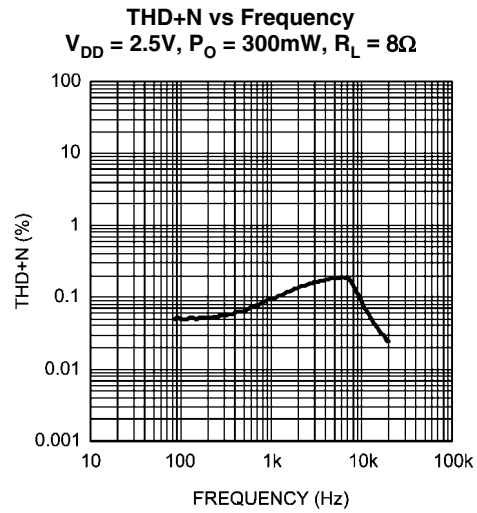
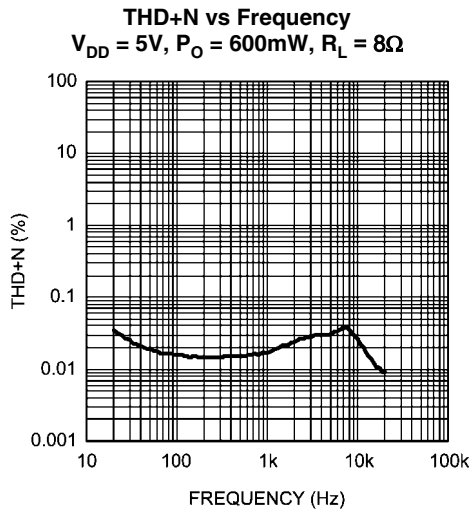
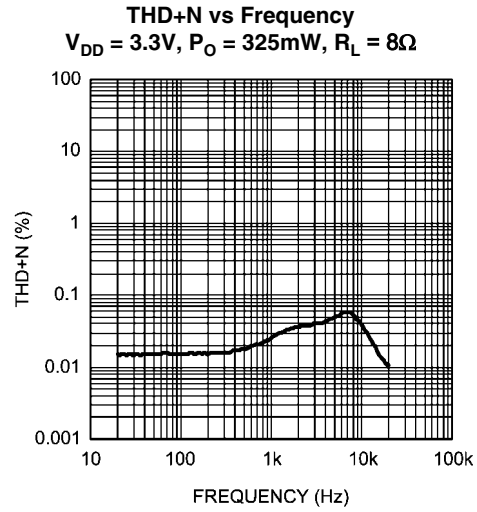
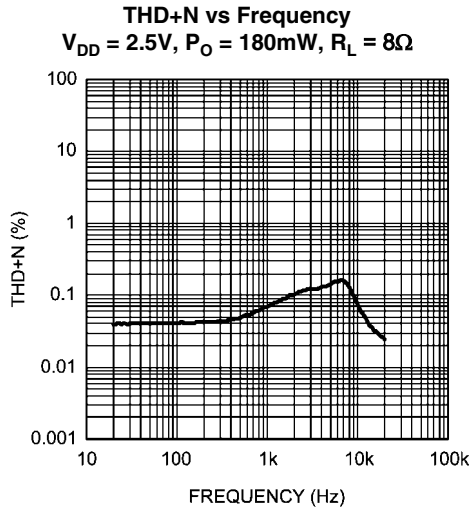

FIGURE 3. CMRR Test Circuit

30110727

Typical Performance Characteristics

For all performance graphs, the Output Gains are set to 0dB, unless otherwise noted.



THD+N vs Frequency
 $V_{DD} = 5V, P_O = 1W, R_L = 3\Omega$

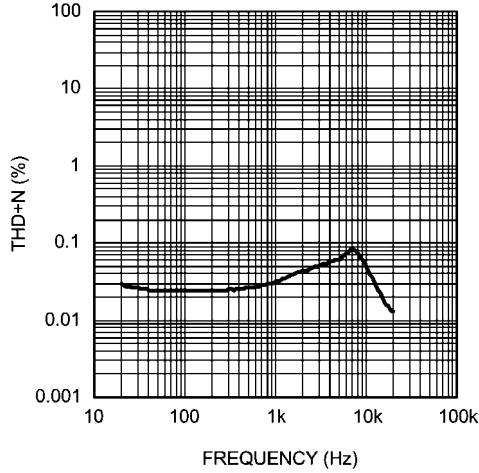

30110754

THD+N vs Output Power
 $A_V = 0dB, f = 1kHz, R_L = 8\Omega$

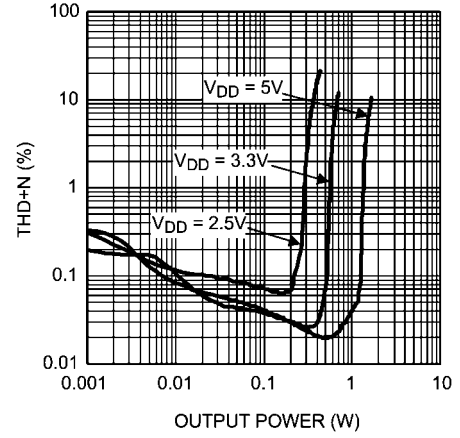

30110733

THD+N vs Output Power
 $A_V = 3dB, f = 1kHz, R_L = 8\Omega$

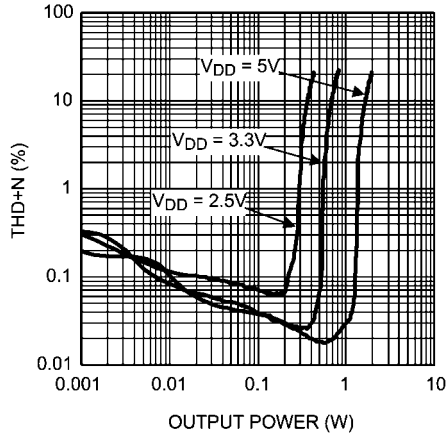

30110734

THD+N vs Output Power
 $A_V = 6dB, f = 1kHz, R_L = 8\Omega$

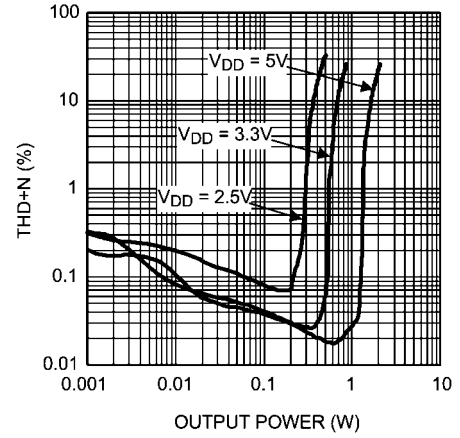

30110735

THD+N vs Output Power
 $A_V = 9dB, f = 1kHz, R_L = 8\Omega$

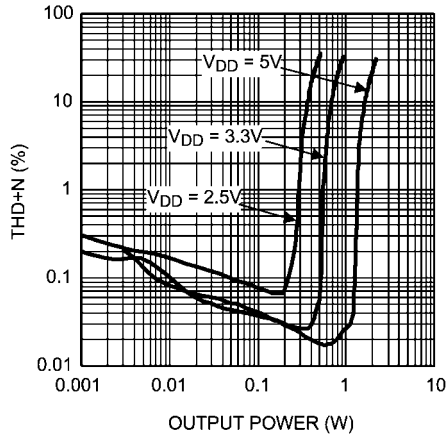

30110736

THD+N vs Output Power
 $A_V = 12dB, f = 1kHz, R_L = 8\Omega$

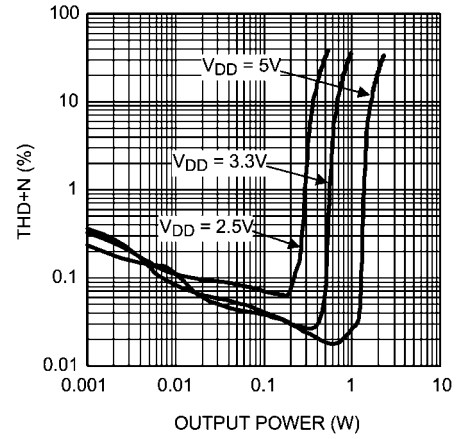

30110737

THD+N vs Output Power
 $A_v = 0\text{dB}$, $f = 1\text{kHz}$, $R_L = 4\Omega$

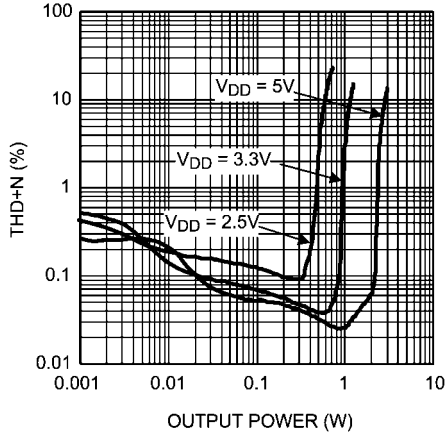

30110738

THD+N vs Output Power
 $A_v = 3\text{dB}$, $f = 1\text{kHz}$, $R_L = 4\Omega$

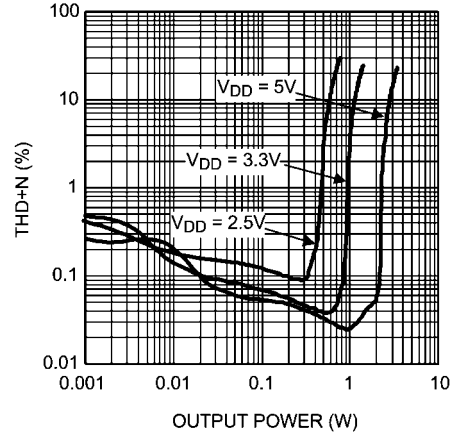

30110739

THD+N vs Output Power
 $A_v = 6\text{dB}$, $f = 1\text{kHz}$, $R_L = 4\Omega$

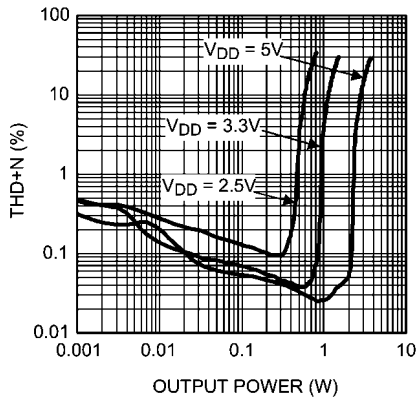

30110775

THD+N vs Output Power
 $A_v = 9\text{dB}$, $f = 1\text{kHz}$, $R_L = 4\Omega$

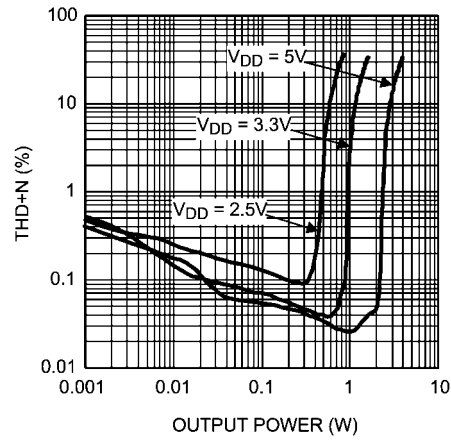

30110741

THD+N vs Output Power
 $A_v = 12\text{dB}$, $f = 1\text{kHz}$, $R_L = 4\Omega$

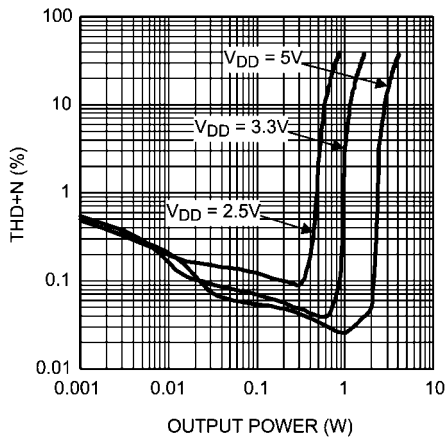

30110742

THD+N vs Output Power
 $A_v = 0\text{dB}$, $f = 1\text{kHz}$, $R_L = 3\Omega$

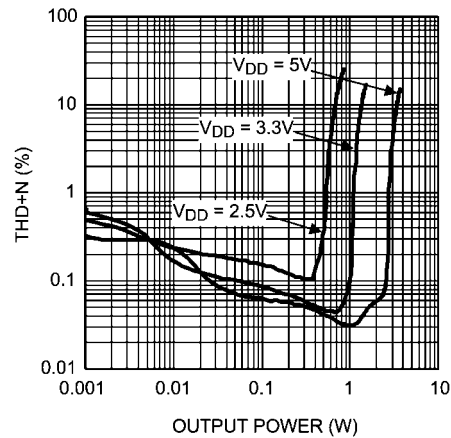

30110743

THD+N vs Output Power
 $A_V = 3\text{dB}$, $f = 1\text{kHz}$, $R_L = 3\Omega$

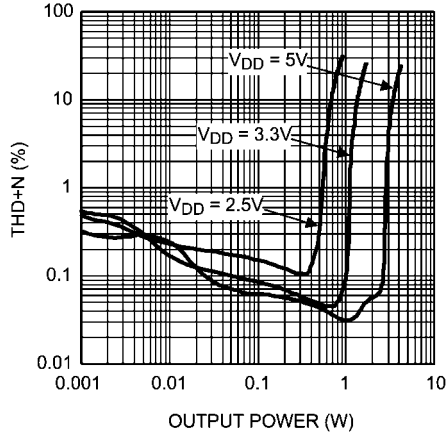

30110744

THD+N vs Output Power
 $A_V = 6\text{dB}$, $f = 1\text{kHz}$, $R_L = 3\Omega$

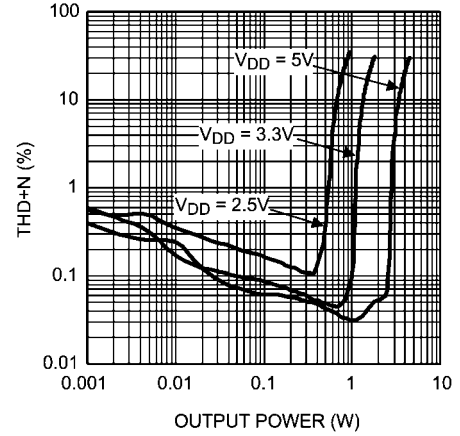

30110745

THD+N vs Output Power
 $A_V = 9\text{dB}$, $f = 1\text{kHz}$, $R_L = 3\Omega$

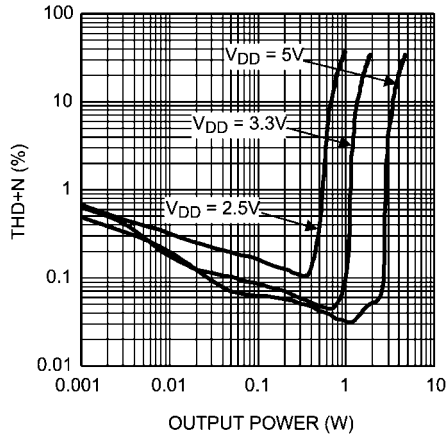

30110746

THD+N vs Output Power
 $A_V = 12\text{dB}$, $f = 1\text{kHz}$, $R_L = 3\Omega$

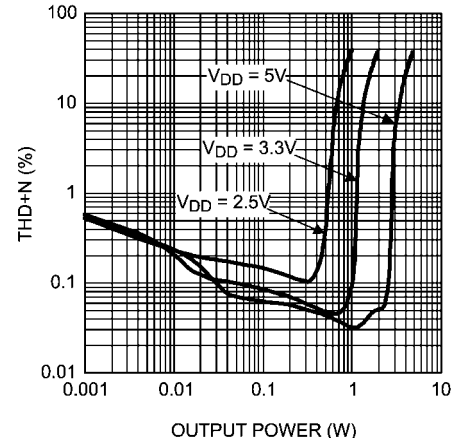

30110747

Efficiency vs Output Power
 $f = 1\text{kHz}$, $R_L = 4\Omega$

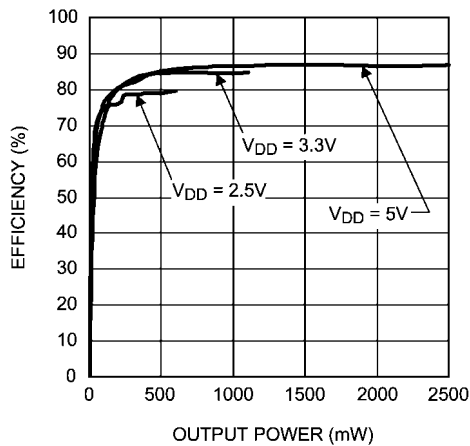

30110755

Efficiency vs Output Power
 $f = 1\text{kHz}$, $R_L = 8\Omega$

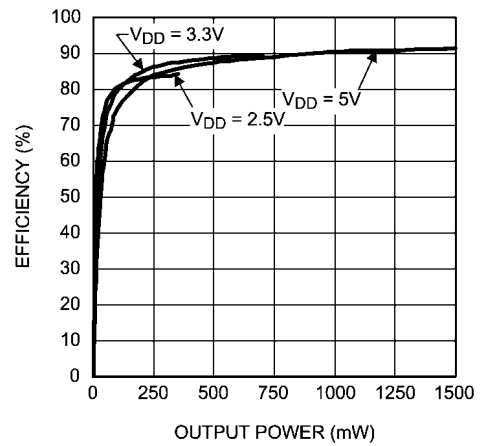

30110756

Power Dissipation vs Output Power
 $f = 1\text{kHz}, R_L = 4\Omega$

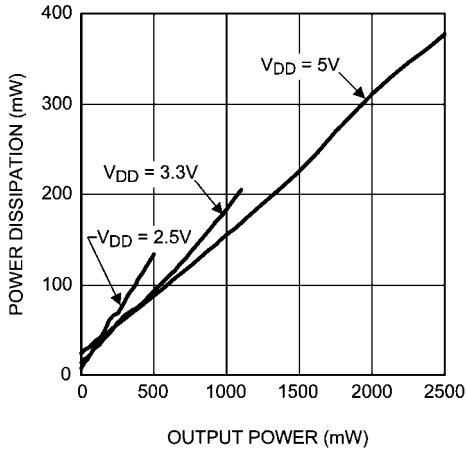

30110757

Power Dissipation vs Output Power
 $f = 1\text{kHz}, R_L = 8\Omega$

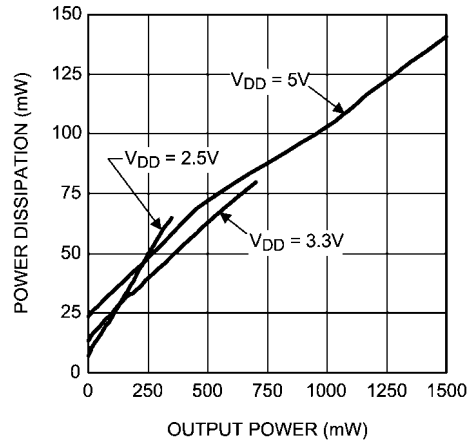

30110758

Output Power vs Supply Voltage
 $f = 1\text{kHz}, R_L = 4\Omega$

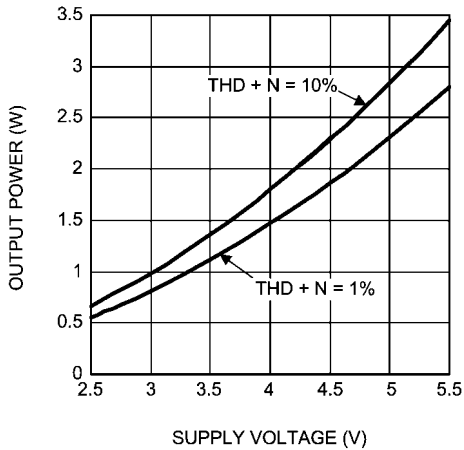

30110759

Output Power vs Supply Voltage
 $f = 1\text{kHz}, R_L = 8\Omega$

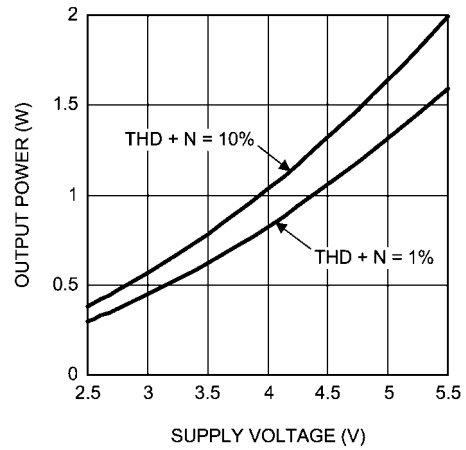

30110760

PSRR vs Frequency
 $V_{DD} = 5\text{V}, V_{RIPPLE} = 200\text{mV}_{P-P}, R_L = 8\Omega$

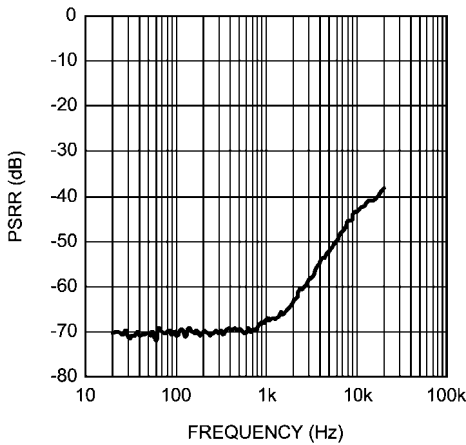

30110762

CMRR vs Frequency
 $V_{DD} = 5\text{V}, V_{RIPPLE} = 1\text{V}_{P-P}, R_L = 8\Omega$

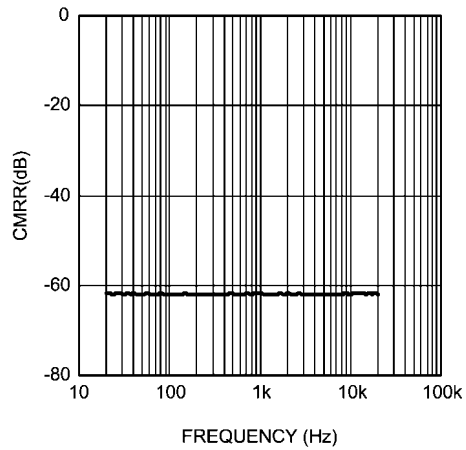

30110763

Spread Spectrum Output Spectrum vs Frequency
 $V_{DD} = 5V, V_{IN} = 1V_{RMS}, R_L = 8\Omega$

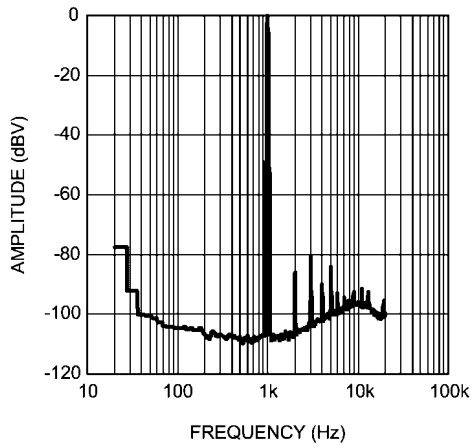

30110764

Wideband Spread Spectrum Output Spectrum vs Frequency
 $V_{DD} = 5V, R_L = 8\Omega$

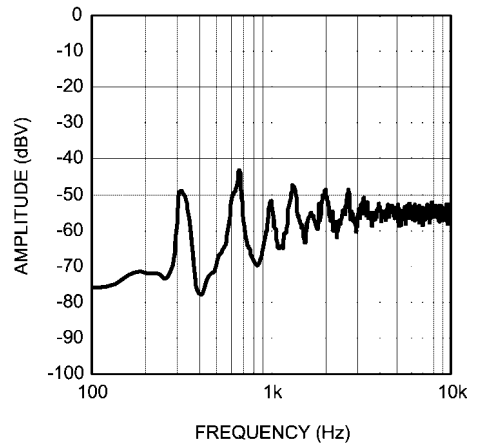

30110765

Supply Current vs Supply Voltage No Load

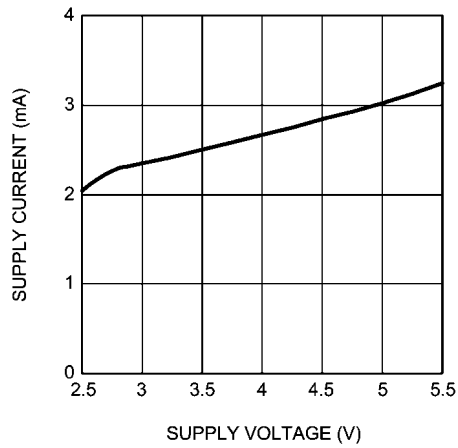

30110766

Shutdown Supply Current vs Supply Voltage No Load

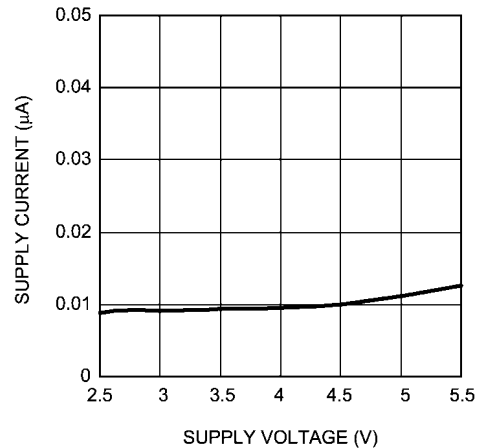

30110767

Application Information

GENERAL AMPLIFIER FUNCTION

The LM48312 mono Class D audio power amplifier features a filterless modulation scheme that reduces external component count, conserving board space and reducing system cost. The outputs of the device transition from V_{DD} to GND with a 300kHz switching frequency. With no signal applied, the outputs (V_{OUTA} and V_{OUTB}) switch with a 50% duty cycle, in phase, causing the two outputs to cancel. This cancellation results in no net voltage across the speaker, thus there is no current to the load in the idle state.

With the input signal applied, the duty cycle (pulse width) of the LM48312 outputs changes. For increasing output voltage, the duty cycle of V_{OUTA} increases, while the duty cycle of V_{OUTB} decreases. For decreasing output voltages, the converse occurs. The difference between the two pulse widths yields the differential output voltage.

ENHANCED EMISSIONS SUPPRESSION SYSTEM (E²S)

The LM48312 features National's patented E²S system that reduces EMI, while maintaining high quality audio reproduction and efficiency. The E²S system features spread spectrum and advanced edge rate control (ERC). The LM48312 ERC greatly reduces the high frequency components of the output square waves by controlling the output rise and fall times, slowing the transitions to reduce RF emissions, while maximizing THD+N and efficiency performance. The overall result of the E²S system is a filterless Class D amplifier that passes FCC Class B radiated emissions standards with 20in of twisted pair cable, with excellent 0.03% THD+N and high 88% efficiency.

SPREAD SPECTRUM

The spread spectrum modulation reduces the need for output filters, ferrite beads or chokes. The switching frequency varies randomly by 30% about a 300kHz center frequency, reducing the wideband spectral content, improving EMI emissions radiated by the speaker and associated cables and traces. Where a fixed frequency class D exhibits large amounts of spectral energy at multiples of the switching frequency, the spread spectrum architecture of the LM48312 spreads that energy over a larger bandwidth (See *Typical Performance Characteristics*). The cycle-to-cycle variation of the switching period does not affect the audio reproduction, efficiency, or PSRR.

DIFFERENTIAL AMPLIFIER EXPLANATION

As logic supplies continue to shrink, system designers are increasingly turning to differential analog signal handling to preserve signal to noise ratios with restricted voltage signs. The LM48312 features a fully differential speaker amplifier. A differential amplifier amplifies the difference between the two input signals. Traditional audio power amplifiers have typically offered only single-ended inputs resulting in a 6dB reduction of SNR relative to differential inputs. The LM48312 also offers the possibility of DC input coupling which eliminates the input coupling capacitors. A major benefit of the fully differential amplifier is the improved common mode rejection ratio (CMRR) over single ended input amplifiers. The increased CMRR of the differential amplifier reduces sensitivity to ground offset related noise injection, especially important in noisy systems.

POWER DISSIPATION AND EFFICIENCY

The major benefit of a Class D amplifier is increased efficiency versus a Class AB. The efficiency of the LM48312 is attributed

to the region of operation of the transistors in the output stage. The Class D output stage acts as current steering switches, consuming negligible amounts of power compared to their Class AB counterparts. Most of the power loss associated with the output stage is due to the IR loss of the MOSFET on-resistance, along with switching losses due to gate charge.

GAIN SETTING

The LM48312 features five internally configured gain settings, 0, 3, 6, 9, and 12dB. The device gain is selected through a single pin (GAIN). The gain settings are shown in Table 2. The gain of the LM48312 is determined at startup. When the LM48312 is powered up or brought out of shutdown, the device checks the state of GAIN, and sets the amplifier gain accordingly. Once the gain is set, the state of GAIN is ignored and the device gain cannot be changed until the device is either shutdown or powered down.

TABLE 2. Gain Setting

GAIN	GAIN SETTING
FLOAT	0dB
V_{DD}	3dB
GND	6dB
20k Ω to V_{DD}	9dB
20k Ω to GND	12dB

For proper gain selection:

1. Use 20k Ω resistors with 10% tolerance or better for the 9dB and 12dB gain settings.
2. Short GAIN to either V_{DD} or GND through 100 Ω or less for the 3dB and 6dB gain settings.
3. FLOAT = 20M Ω or more for the 0dB gain setting.

SHUTDOWN FUNCTION

The LM48312 features a low current shutdown mode. Set $\overline{SD} = \text{GND}$ to disable the amplifier and reduce supply current to 0.01 μA .

Switch \overline{SD} between GND and V_{DD} for minimum current consumption is shutdown. The LM48312 may be disabled with shutdown voltages in between GND and V_{DD} , the idle current will be greater than the typical 0.1 μA value. Increased THD+N may also be observed when a voltage of less than V_{DD} is applied to \overline{SD} .

The LM48312 shutdown input has an internal pulldown resistor. The purpose of this resistor is to eliminate any unwanted state changes when \overline{SD} is floating. To minimize shutdown current, \overline{SD} should be driven to GND or left floating. If \overline{SD} is not driven to GND or floating, an increase in shutdown supply current will be noticed.

PROPER SELECTION OF EXTERNAL COMPONENTS

Audio Amplifier Power Supply Bypassing/Filtering

Proper power supply bypassing is critical for low noise performance and high PSRR. Place the supply bypass capacitors as close to the device as possible. Typical applications employ a voltage regulator with 10 μF and 0.1 μF bypass capacitors that increase supply stability. These capacitors do not eliminate the need for bypassing of the LM48312 supply pins. A 1 μF capacitor is recommended.

Audio Amplifier Input Capacitor Selection

Input capacitors may be required for some applications, or when the audio source is single-ended. Input capacitors block the DC component of the audio signal, eliminating any conflict between the DC component of the audio source and the bias voltage of the LM48312. The input capacitors create a high-pass filter with the input resistors R_{IN} . The -3dB point of the high pass filter is found using equation (1) below.

$$f = 1 / 2\pi R_{IN} C_{IN} \quad (1)$$

Where R_{IN} is the value of the input resistor given in the *Electrical Characteristics* table.

The input capacitors can also be used to remove low frequency content from the audio signal. Small speakers cannot reproduce, and may even be damaged by low frequencies. High pass filtering the audio signal helps protect the speakers. When the LM48312 is using a single-ended source, power supply noise on the ground is seen as an input signal. Setting the high-pass filter point above the power supply noise frequencies, 217Hz in a GSM phone, for example, filters out the noise such that it is not amplified and heard on the output. Capacitors with a tolerance of 10% or better are recommended for impedance matching and improved CMRR and PSRR.

PCB LAYOUT GUIDELINES

As output power increases, interconnect resistance (PCB traces and wires) between the amplifier, load and power supply create a voltage drop. The voltage loss due to the traces between the LM48312 and the load results in lower output power and decreased efficiency. Higher trace resistance between the supply and the LM48312 has the same effect as a poorly regulated supply, increasing ripple on the supply line, and reducing peak output power. The effects of residual trace resistance increases as output current increases due to higher output power, decreased load impedance or both. To maintain the highest output voltage swing and corresponding peak output power, the PCB traces that connect the output pins to the load and the supply pins to the power supply should be as wide as possible to minimize trace resistance.

The use of power and ground planes will give the best THD +N performance. In addition to reducing trace resistance, the

Single-Ended Audio Amplifier Configuration

The LM48312 is compatible with single-ended sources. When configured for single-ended inputs, input capacitors must be used to block DC component at the input of the device. Figure 4 shows the typical single-ended applications circuit.

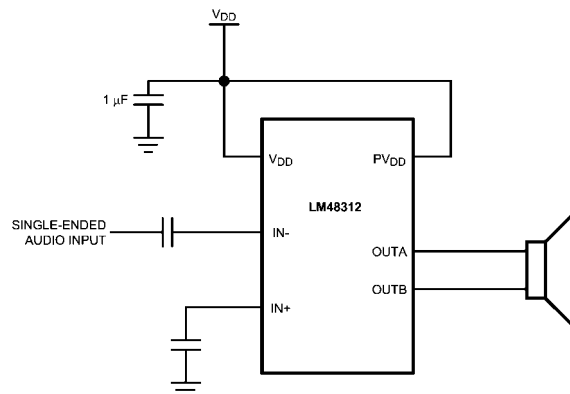

FIGURE 4. Single-Ended Input Configuration

301107a6

use of power planes creates parasitic capacitors that help to filter the power supply line.

The inductive nature of the transducer load can also result in overshoot on one of both edges, clamped by the parasitic diodes to GND and V_{DD} in each case. From an EMI standpoint, this is an aggressive waveform that can radiate or conduct to other components in the system and cause interference. It is essential to keep the power and output traces short and well shielded if possible. Use of ground planes beads and micro-strip layout techniques are all useful in preventing unwanted interference.

As the distance from the LM48312 and the speaker increases, the amount of EMI radiation increases due to the output wires or traces acting as antennas become more efficient with length. Ferrite chip inductors placed close to the LM48312 outputs may be needed to reduce EMI radiation.

Demo Board Schematic

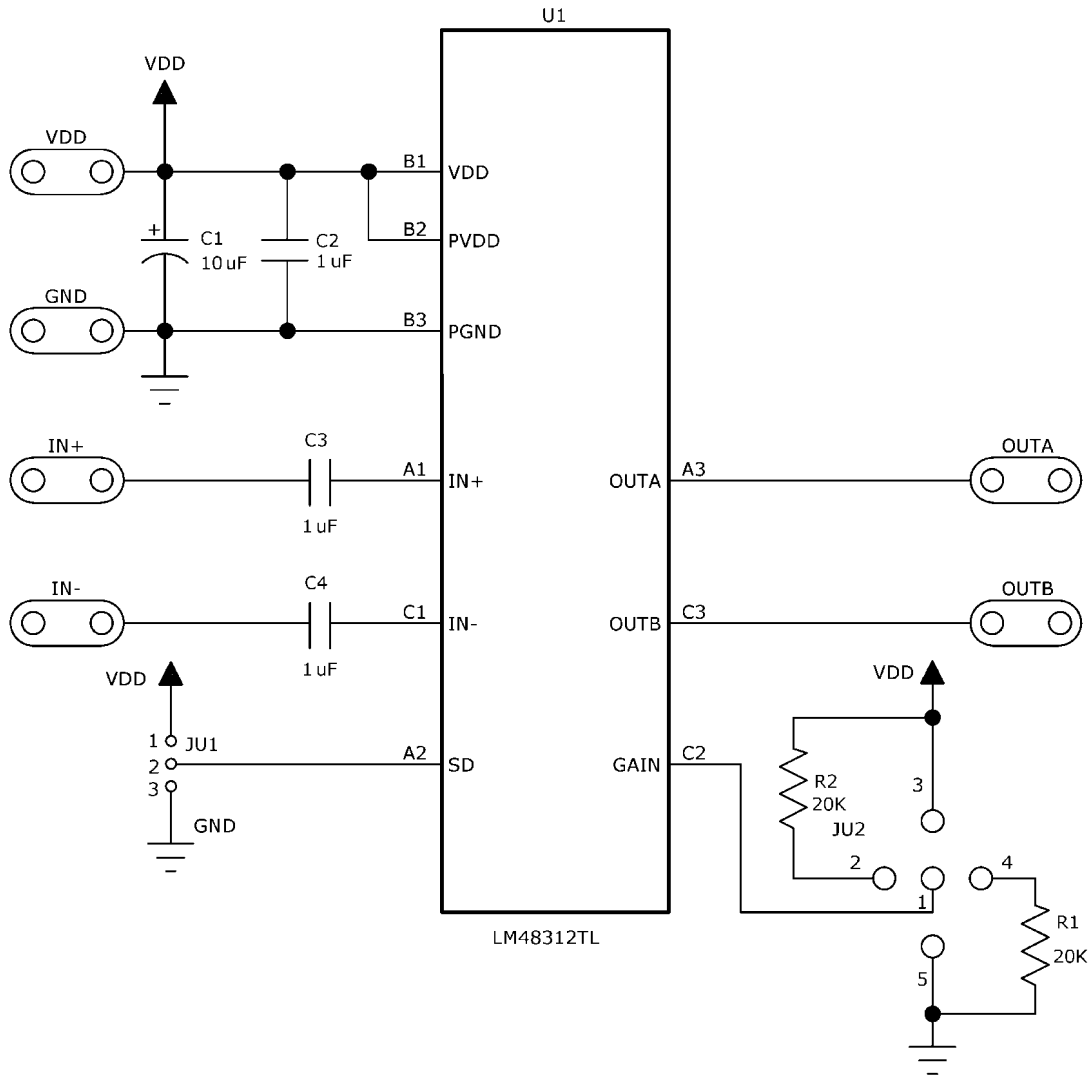

FIGURE 5: LM48312 Demoboard Schematic

30110768

LM48312TL Demoboard Bill of Materials

Designator	Quantity	Description
C1	1	10 μ F \pm 10% 16V Tantalum Capacitor (B Case) AVX TPSB106K016R0800
C2	1	1 μ F \pm 10% 16V X5R Ceramic Capacitor (603) Panasonic ECJ-1VB1C105K
C3, C4	2	1 μ F \pm 10% 16V X7R Ceramic Capacitor (1206) Panasonic ECJ-3YB1C105K
R1, R2	2	20k Ω \pm 5% 1/10W Thick Film Resistor (603) Vishay CRCW060320R0JNEA
LM48312TL	1	LM48312TL (9-Bump microSMD)

PC Board Layout

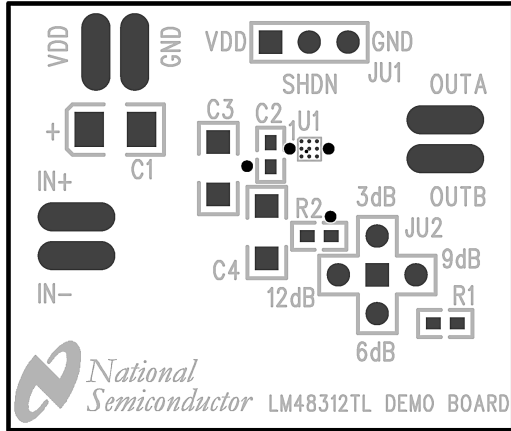

Top Silkscreen

30110769

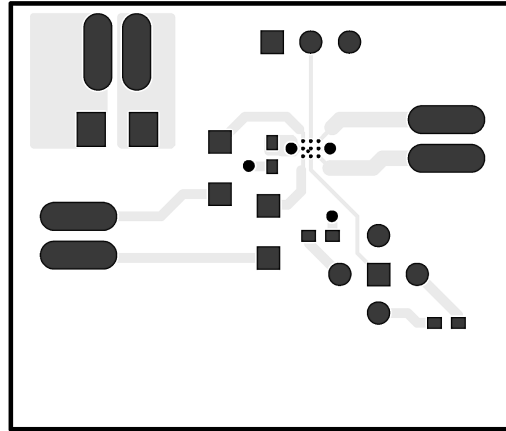

Top Layer

30110770

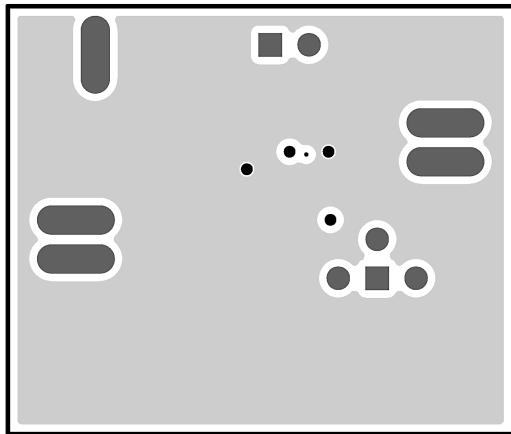

Layer 2 (GND)

30110771

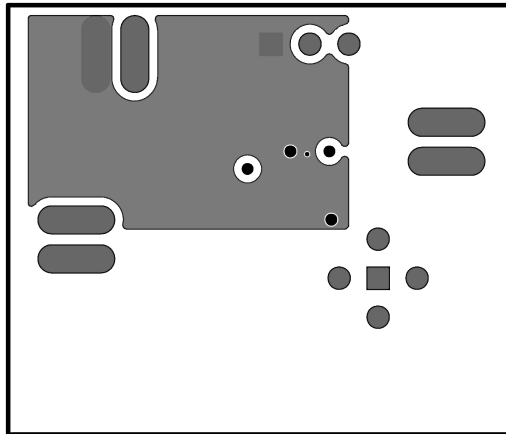

Layer 3 (V_{DD})

30110772

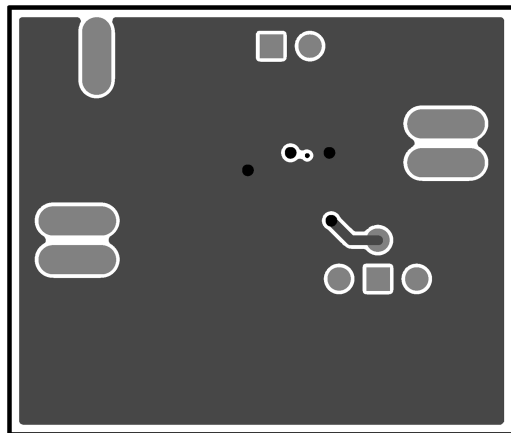

Bottom Layer

30110773

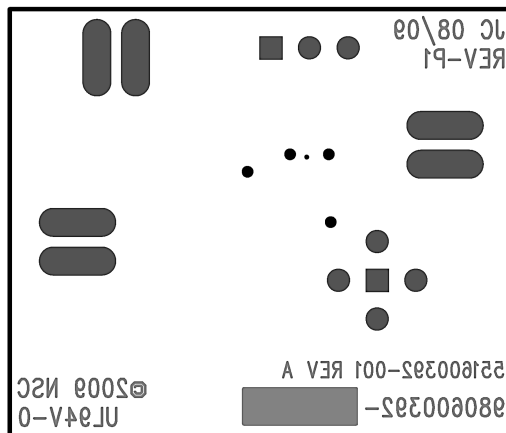

Bottom Silkscreen

30110774

Revision History

Rev	Date	Description
1.0	01/20/10	Initial WEB released.
1.01	03/19/10	Text edits under the ENHANCED EMISSIONS section.

Physical Dimensions inches (millimeters) unless otherwise noted

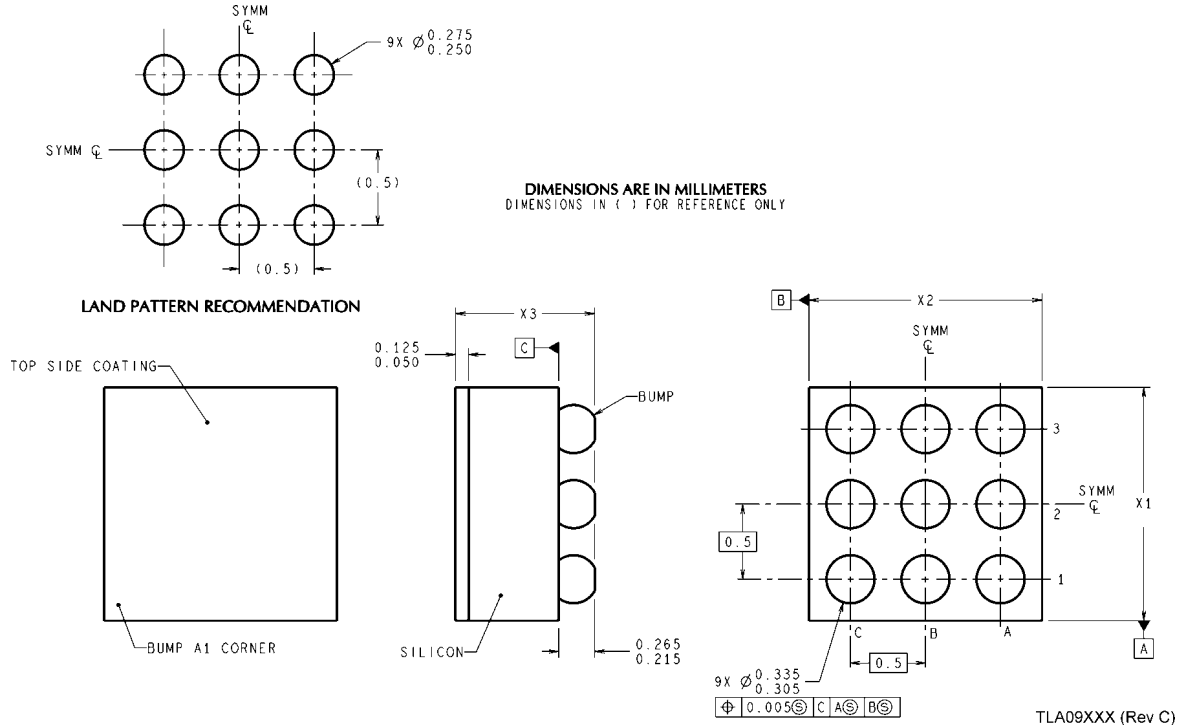

9 Bump micro SMD
Order Number LM48312TLE
NS Package Number TLA09BCA
X1 = 1.532±0.03mm X2 = 1.556±0.03mm X3 = 0.6±0.075mm

Notes

For more National Semiconductor product information and proven design tools, visit the following Web sites at:
www.national.com

Products		Design Support	
Amplifiers	www.national.com/amplifiers	WEBENCH® Tools	www.national.com/webench
Audio	www.national.com/audio	App Notes	www.national.com/appnotes
Clock and Timing	www.national.com/timing	Reference Designs	www.national.com/refdesigns
Data Converters	www.national.com/adc	Samples	www.national.com/samples
Interface	www.national.com/interface	Eval Boards	www.national.com/evalboards
LVDS	www.national.com/lvds	Packaging	www.national.com/packaging
Power Management	www.national.com/power	Green Compliance	www.national.com/quality/green
Switching Regulators	www.national.com/switchers	Distributors	www.national.com/contacts
LDOs	www.national.com/lido	Quality and Reliability	www.national.com/quality
LED Lighting	www.national.com/led	Feedback/Support	www.national.com/feedback
Voltage References	www.national.com/vref	Design Made Easy	www.national.com/easy
PowerWise® Solutions	www.national.com/powerwise	Applications & Markets	www.national.com/solutions
Serial Digital Interface (SDI)	www.national.com/sdi	Mil/Aero	www.national.com/milaero
Temperature Sensors	www.national.com/tempensors	SolarMagic™	www.national.com/solarmagic
PLL/VCO	www.national.com/wireless	PowerWise® Design University	www.national.com/training

THE CONTENTS OF THIS DOCUMENT ARE PROVIDED IN CONNECTION WITH NATIONAL SEMICONDUCTOR CORPORATION ("NATIONAL") PRODUCTS. NATIONAL MAKES NO REPRESENTATIONS OR WARRANTIES WITH RESPECT TO THE ACCURACY OR COMPLETENESS OF THE CONTENTS OF THIS PUBLICATION AND RESERVES THE RIGHT TO MAKE CHANGES TO SPECIFICATIONS AND PRODUCT DESCRIPTIONS AT ANY TIME WITHOUT NOTICE. NO LICENSE, WHETHER EXPRESS, IMPLIED, ARISING BY ESTOPPEL OR OTHERWISE, TO ANY INTELLECTUAL PROPERTY RIGHTS IS GRANTED BY THIS DOCUMENT.

TESTING AND OTHER QUALITY CONTROLS ARE USED TO THE EXTENT NATIONAL DEEMS NECESSARY TO SUPPORT NATIONAL'S PRODUCT WARRANTY. EXCEPT WHERE MANDATED BY GOVERNMENT REQUIREMENTS, TESTING OF ALL PARAMETERS OF EACH PRODUCT IS NOT NECESSARILY PERFORMED. NATIONAL ASSUMES NO LIABILITY FOR APPLICATIONS ASSISTANCE OR BUYER PRODUCT DESIGN. BUYERS ARE RESPONSIBLE FOR THEIR PRODUCTS AND APPLICATIONS USING NATIONAL COMPONENTS. PRIOR TO USING OR DISTRIBUTING ANY PRODUCTS THAT INCLUDE NATIONAL COMPONENTS, BUYERS SHOULD PROVIDE ADEQUATE DESIGN, TESTING AND OPERATING SAFEGUARDS.

EXCEPT AS PROVIDED IN NATIONAL'S TERMS AND CONDITIONS OF SALE FOR SUCH PRODUCTS, NATIONAL ASSUMES NO LIABILITY WHATSOEVER, AND NATIONAL DISCLAIMS ANY EXPRESS OR IMPLIED WARRANTY RELATING TO THE SALE AND/OR USE OF NATIONAL PRODUCTS INCLUDING LIABILITY OR WARRANTIES RELATING TO FITNESS FOR A PARTICULAR PURPOSE, MERCHANTABILITY, OR INFRINGEMENT OF ANY PATENT, COPYRIGHT OR OTHER INTELLECTUAL PROPERTY RIGHT.

LIFE SUPPORT POLICY

NATIONAL'S PRODUCTS ARE NOT AUTHORIZED FOR USE AS CRITICAL COMPONENTS IN LIFE SUPPORT DEVICES OR SYSTEMS WITHOUT THE EXPRESS PRIOR WRITTEN APPROVAL OF THE CHIEF EXECUTIVE OFFICER AND GENERAL COUNSEL OF NATIONAL SEMICONDUCTOR CORPORATION. As used herein:

Life support devices or systems are devices which (a) are intended for surgical implant into the body, or (b) support or sustain life and whose failure to perform when properly used in accordance with instructions for use provided in the labeling can be reasonably expected to result in a significant injury to the user. A critical component is any component in a life support device or system whose failure to perform can be reasonably expected to cause the failure of the life support device or system or to affect its safety or effectiveness.

National Semiconductor and the National Semiconductor logo are registered trademarks of National Semiconductor Corporation. All other brand or product names may be trademarks or registered trademarks of their respective holders.

Copyright© 2010 National Semiconductor Corporation

For the most current product information visit us at www.national.com



National Semiconductor Americas Technical Support Center
 Email: support@nsc.com
 Tel: 1-800-272-9959

National Semiconductor Europe Technical Support Center
 Email: europe.support@nsc.com

National Semiconductor Asia Pacific Technical Support Center
 Email: ap.support@nsc.com

National Semiconductor Japan Technical Support Center
 Email: jpn.feedback@nsc.com