

LM48823 Boomer® Audio Power Amplifier Series

Mono, Bridge-Tied Load, Ceramic Speaker Driver with I²C Volume Control and Reset

General Description

The LM48823 is a single supply, mono, ceramic speaker driver with an integrated charge-pump, designed for portable devices, such as cell phones, where board space is at a premium. The LM48823 charge pump allows the device to deliver 5.4V_{RMS} from a single 4.2V supply.

The LM48823 features high power supply rejection ratio (PSRR), 93dB at 217Hz, allowing the device to operate in noisy environments without additional power supply conditioning. Flexible power supply requirements allow operation from 2.0V to 4.5V. The LM48823 features an active low reset input that reverts the device to its default state. Additionally, the LM48823 features a 32-step I²C volume control. The low power Shutdown mode reduces supply current consumption to 0.01μA.

The LM48823's superior click and pop suppression eliminates audible transients on power-up/down and during shutdown. The LM48823 is available in an ultra-small 16-bump micro SMD package (2mmx2mm).

Key Specifications

■ Output Voltage at V _{DD} = 4.2V, R _L = 2.2μF + 15Ω THD+N ≤ 1%	5.4V _{RMS} (typ)
■ Quiescent Power Supply Current at 4.2V	3.3mA (typ)
■ PSRR at 217Hz	93dB (typ)
■ Shutdown current	0.01μA (typ)

Features

- Integrated Charge Pump
- Bridge-tied Load Output
- High PSRR
- I²C Volume and Mode Control
- Reset Input
- Advanced Click-and-Pop Suppression
- Low Supply Current
- Minimum external components
- Micro-power shutdown
- Available in space-saving 16-bump μSMD package

Applications

- Cell phones
- Smart phones
- Portable media devices
- Notebook PCs

Typical Application

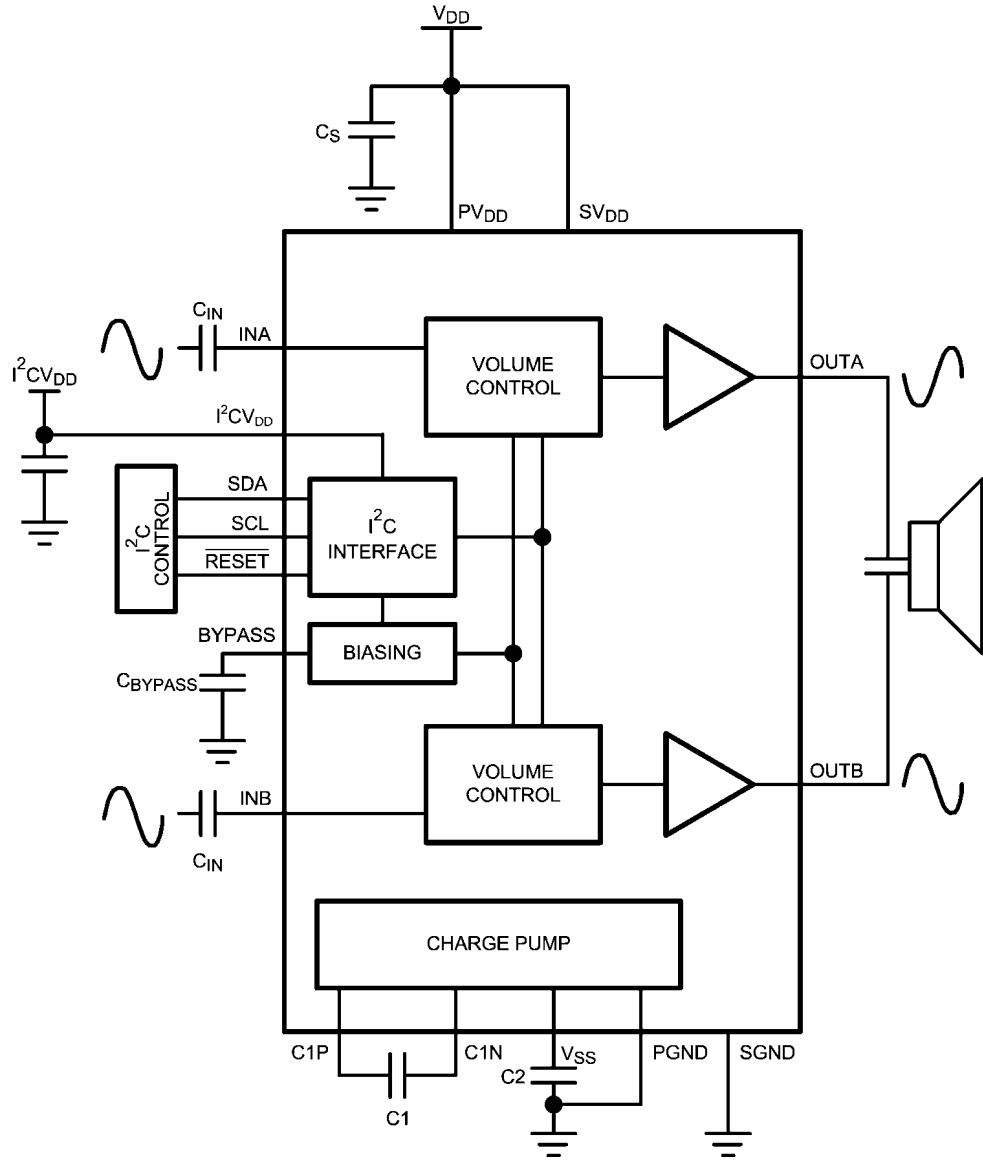

300684e1

FIGURE 1. Typical Audio Amplifier Application Circuit

Connection Diagrams

TL Package
2mm x 2mm x 0.8mm

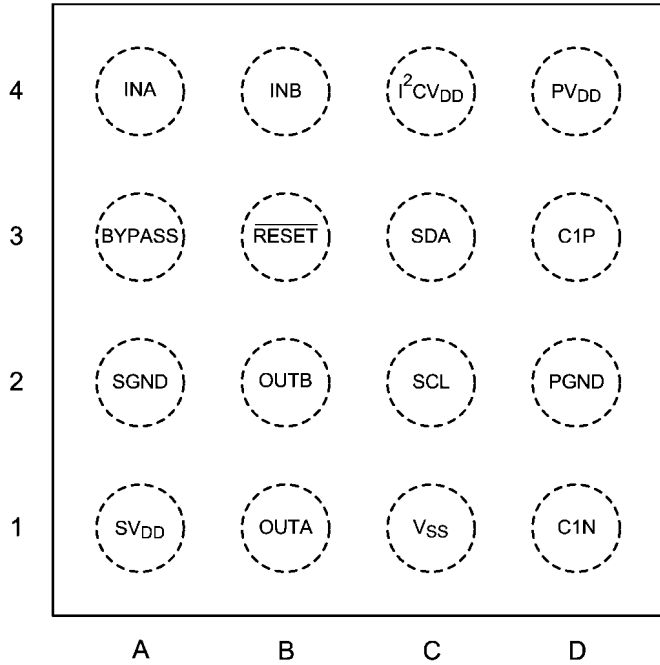

Top View
See NS Package Number TLA1611A

300684e0

16-Bump micro SMD Marking

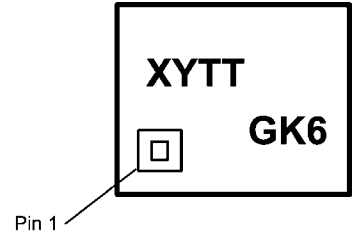

300684g7

Top View
XY – Date Code
TT – Lot Traceability
G – Boomer Family
K6 – LM48823TL

Ordering Information

Order Number	Package	Package DWG #	Transport Media	MSL Level	Green Status
LM48823TL	16-Bump micro SMD	TLA1611A	250 units on tape and reel	1	NOPB
LM48823TLX	16-Bump micro SMD	TLA1611A	3000 units on tape and reel	1	NOPB

TABLE 1. Bump Descriptions

Pin Designator	Pin Name	Pin Function
A1	SV_{DD}	Signal Power Supply
A2	SGND	Signal Ground
A3	BYPASS	Amplifier Reference Bypass
A4	INA	Amplifier Inverting input A
B1	OUTA	Amplifier Inverting output A
B2	OUTB	Amplifier Non-Inverting Output B
B3	$\overline{\text{RESET}}$	Active Low Reset Input. Connect to V_{DD} for normal operation. Toggle between V_{DD} and GND to reset the device.
B4	INB	Amplifier Non-Inverting Input B
C1	V_{SS}	Charge Pump Output
C2	SCL	I ² C Serial Clock Input
C3	SDA	I ² C Serial Data Input
C4	I ² C V_{DD}	I ² C Supply Voltage
D1	C1N	Charge Pump Flying Capacitor Negative Terminal
D2	PGND	Power Ground
D3	C1P	Charge Pump Flying Capacitor Positive Terminal
D4	PV_{DD}	Power Supply

Absolute Maximum Ratings (Notes 1, 2)

If Military/Aerospace specified devices are required, please contact the National Semiconductor Sales Office/Distributors for availability and specifications.

Supply Voltage (Note 1)	5.25V
Storage Temperature	-65°C to +150°C
Input Voltage	-0.3V to $V_{DD} + 0.3V$
Power Dissipation (Note 3)	Internally Limited
ESD Rating (Note 4)	8kV
ESD Rating (Note 5)	250V
Junction Temperature	150°C

Thermal Resistance

 θ_{JA} (typ) - (TLA1611A)

63.2°C/W

Operating Ratings

Temperature Range

 $T_{MIN} \leq T_A \leq T_{MAX}$ $-40^\circ\text{C} \leq T_A \leq +85^\circ\text{C}$

Supply Voltage

 PV_{DD} and SV_{DD} $2.0V \leq V_{DD} \leq 4.5V$ I^2CV_{DD} $1.8V \leq I^2CV_{DD} \leq 4.5V$ **Audio Amplifier Electrical Characteristics $V_{DD} = 4.2V$** (Notes 1, 2)

The following specifications apply for $A_V = 6\text{dB}$, $R_L = 2.2\mu\text{F} + 15\Omega$, $C_1 = C_2 = 2.2\mu\text{F}$, $f = 1\text{kHz}$, unless otherwise specified. Limits apply for $T_A = 25^\circ\text{C}$.

Symbol	Parameter	Conditions	LM48823		Units (Limits)
			Typical (Note 6)	Limits (Note 7)	
I_{DD}	Quiescent Power Supply Current	$V_{IN} = 0V$, $R_L = \infty$	3.3	4.3	mA (max)
I_{SD}	Shutdown Current	Shutdown Enabled	0.01	1	μA (max)
V_{OS}	Differential Output Offset Voltage	$V_{IN} = 0V$	0.5	3	mV (max)
V_{IH}	Logic High Input Threshold	RESET		1.4	V (min)
V_{IL}		RESET		0.4	V (max)
A_V	Gain	Minimum Gain Setting	-70		dB
		Maximum Gain Setting	24		dB
R_{IN}	Input Resistance	Maximum Gain Setting	9	7 11	k Ω (min) k Ω (max)
		Minimum Gain Setting	80	64 96	k Ω (min) k Ω (max)
V_O	Output Voltage	$R_L = 2.2\mu\text{F} + 15\Omega$, THD+N = 1% $f = 1\text{kHz}$	5.4		V_{RMS}
		$f = 5\text{kHz}$	3.1		V_{RMS}
THD+N	Total Harmonic Distortion + Noise	$V_O = 4V_{RMS}$	0.015		%
PSRR	Power Supply Rejection Ratio	$V_{RIPPLE} = 200\text{mV}_{P-P}$ Sine, Inputs AC GND, $C_{IN} = 1\mu\text{F}$, input referred			
		$f = 217\text{Hz}$	93	82	dB (min)
		$f = 1\text{kHz}$	93		dB
SNR	Signal-to-Noise-Ratio	$P_{OUT} = 40\text{mW}$, $R_L = 16\Omega$ $f = 1\text{kHz}$	119		dB
ϵ_{OS}	Output Noise	$A_V = 4\text{dB}$, Input Referred, A-weighted Filter	5.5		μV
T_{WU}	Wake-Up Time		200		μs

I2C Interface Characteristics $V_{DD} = 3.0V$ (Notes 1, 2)

The following specifications apply for $A_V = 6dB$, $R_L = 2.2\mu F + 15\Omega$, $C1 = C2 = 2.2\mu F$, $f = 1kHz$, unless otherwise specified. Limits apply for $T_A = 25^\circ C$.

Symbol	Parameter	Conditions	LM48823		Units (Limits)
			Typical (Note 6)	Limits (Note 7)	
t_1	SCL period			2.5	μs (min)
t_2	SDA Setup Time			100	ns (min)
t_3	SDA Stable Time			0	ns (min)
t_4	Start Condition Time			100	ns (min)
t_5	Stop Condition Time			100	ns (min)
V_{IH}	Logic High Input Threshold			$0.7 \times I^2CV_{DD}$	V (min)
V_{IL}	Logic Low Input Threshold			$0.3 \times I^2CV_{DD}$	V (max)

Note 1: : "Absolute Maximum Ratings" indicate limits beyond which damage to the device may occur, including inoperability and degradation of device reliability and/or performance. Functional operation of the device and/or non-degradation at the *Absolute Maximum Ratings* or other conditions beyond those indicated in the *Recommended Operating Conditions* is not implied. The *Recommended Operating Conditions* indicate conditions at which the device is functional and the device should not be operated beyond such conditions. All voltages are measured with respect to the ground pin, unless otherwise specified.

Note 2: The *Electrical Characteristics* tables list guaranteed specifications under the listed *Recommended Operating Conditions* except as otherwise modified or specified by the *Electrical Characteristics Conditions* and/or Notes. Typical specifications are estimations only and are not guaranteed.

Note 3: The maximum power dissipation must be derated at elevated temperatures and is dictated by T_{JMAX} , θ_{JA} , and the ambient temperature, T_A . The maximum allowable power dissipation is $P_{DMAX} = (T_{JMAX} - T_A) / \theta_{JA}$ or the number given in *Absolute Maximum Ratings*, whichever is lower.

Note 4: Human body model, applicable std. JESD22-A114C.

Note 5: Machine model, applicable std. JESD22-A115-A.

Note 6: Typical values represent most likely parametric norms at $T_A = +25^\circ C$, and at the *Recommended Operation Conditions* at the time of product characterization and are not guaranteed.

Note 7: Datasheet min/max specification limits are guaranteed by test or statistical analysis.

Typical Performance Characteristics

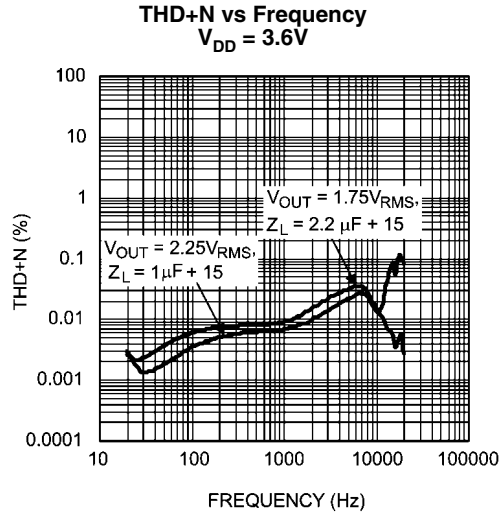

300684g9

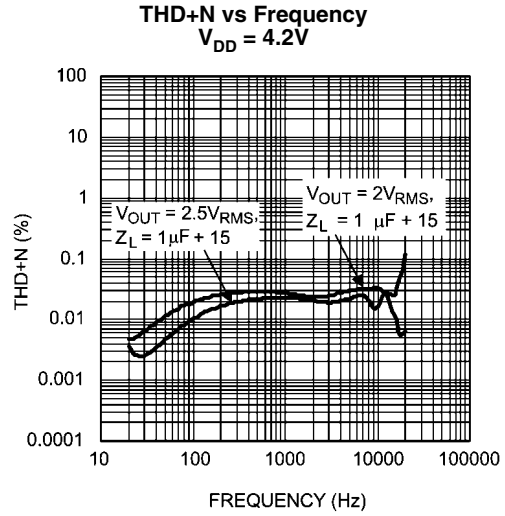

300684h0

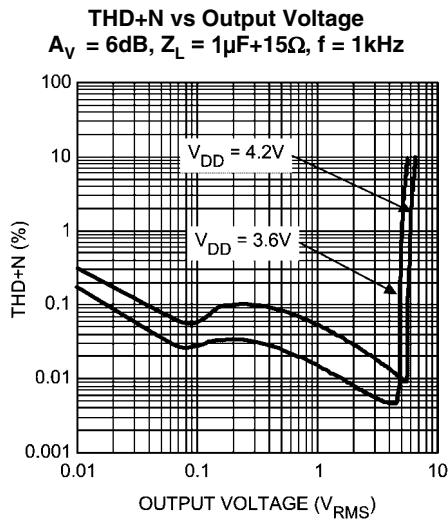

300684i2

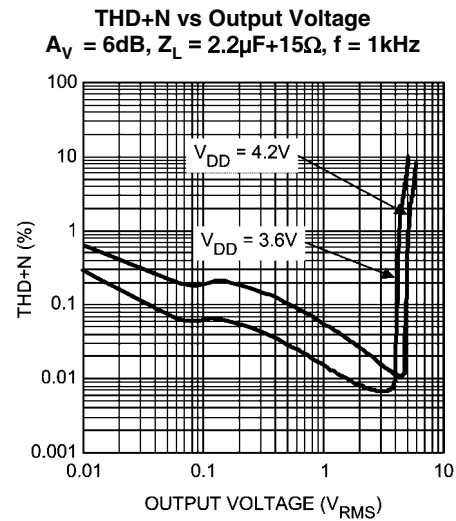

300684i3

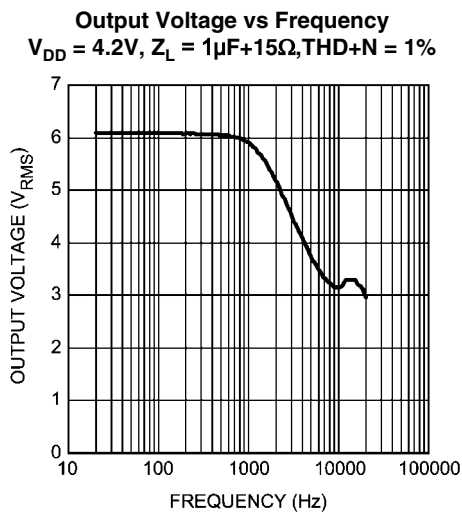

300684i6

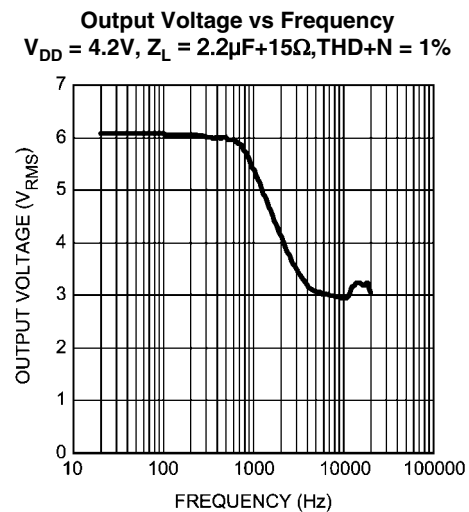

300684i7

Power Consumption vs Output Voltage
 $V_{DD} = 3.6V, Z_L = 1\mu F + 15\Omega$

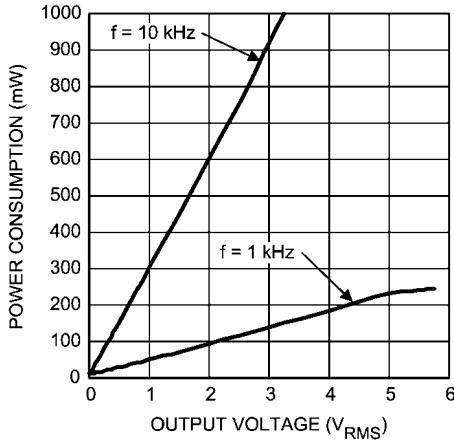

Power Consumption vs Output Voltage
 $V_{DD} = 3.6V, Z_L = 2.2\mu F + 15\Omega$

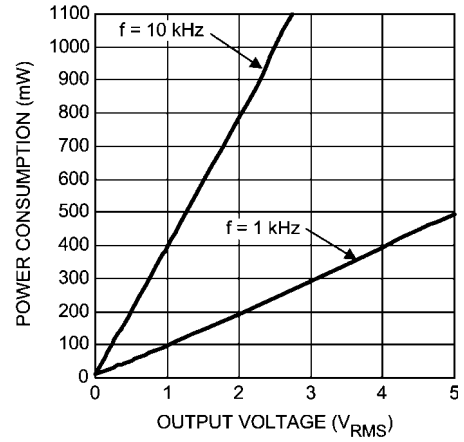

Power Consumption vs Output Voltage
 $V_{DD} = 4.2V, Z_L = 1\mu F + 15\Omega$

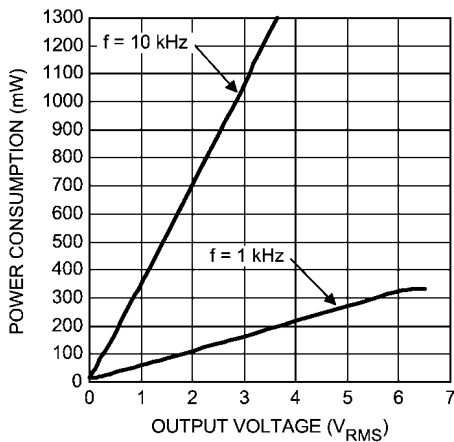

Power Consumption vs Output Voltage
 $V_{DD} = 4.2V, Z_L = 2.2\mu F + 15\Omega$

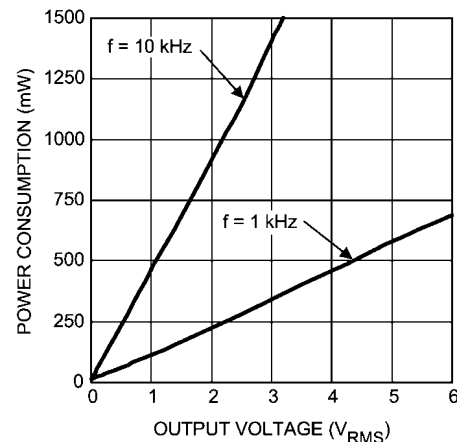

Output Voltage vs Supply Voltage
 $Z_L = 1\mu F + 15\Omega, THD+N = 1\%$

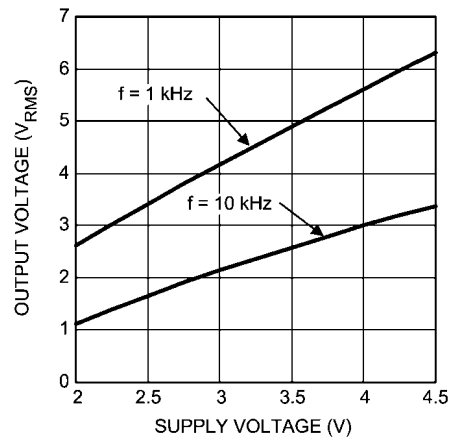

Output Voltage vs Supply Voltage
 $Z_L = 2.2\mu F + 15\Omega, THD+N = 1\%$

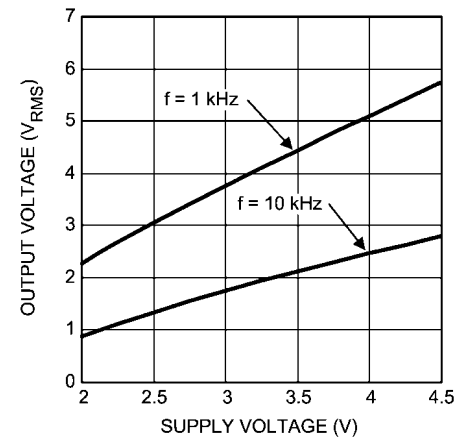

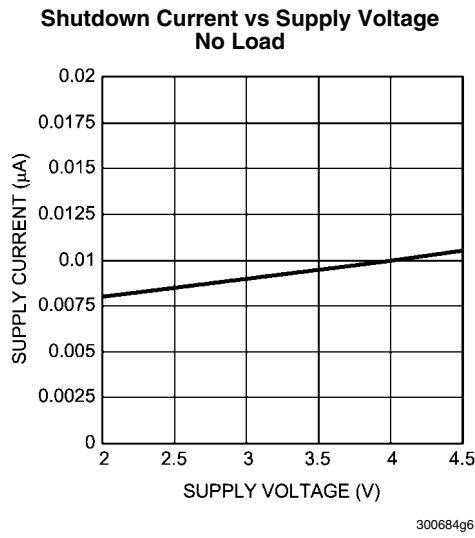
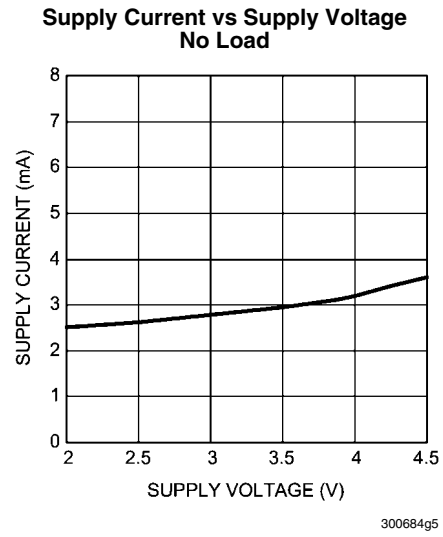
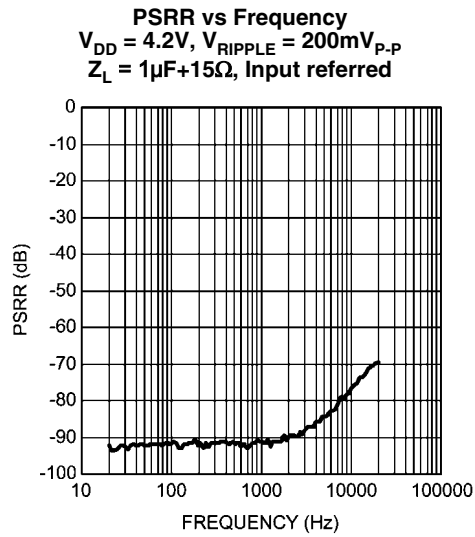

Application Information

I²C COMPATIBLE INTERFACE

The LM48823 is controlled through an I²C compatible serial interface that consists of a serial data line (SDA) and a serial clock (SCL). The clock line is uni-directional. The data line is bi-directional (open drain). The LM48823 and the master can communicate at clock rates up to 400kHz. Figure 2 shows the I²C interface timing diagram. Data on the SDA line must be stable during the HIGH period of SCL. The LM48823 is a transmit/receive slave-only device, reliant upon the master to generate the SCL signal. Each transmission sequence is framed by a START condition and a STOP condition (Figure 3). Each data word, device address and data, transmitted over the bus is 8 bits long and is always followed by an acknowledge pulse (Figure 4). The LM48823 device address is 1110110.

I²C BUS FORMAT

The I²C bus format is shown in Figure 4. The START signal, the transition of SDA from HIGH to LOW while SCL is HIGH, is generated, alerting all devices on the bus that a device address is being written to the bus.

The 7-bit device address is written to the bus, most significant bit (MSB) first, followed by the R/W bit. R/W = 0 indicates the master is writing to the slave device, R/W = 1 indicates the master wants to read data from the slave device. Set R/W = 0; the LM48823 is a WRITE-ONLY device and will not respond to the R/W = 1. The data is latched in on the rising edge of the clock. Each address bit must be stable while SCL is HIGH. After the last address bit is transmitted, the master device releases SDA, during which time, an acknowledge clock pulse is generated by the slave device. If the LM48823 receives the correct address, the device pulls the SDA line low, generating an acknowledge bit (ACK).

Once the master device registers the ACK bit, the 8-bit register data word is sent. Each data bit should be stable while SCL is HIGH. After the 8-bit register data word is sent, the LM48823 sends another ACK bit. Following the acknowledgement of the register data word, the master issues a STOP bit, allowing SDA to go high while SCL is high.

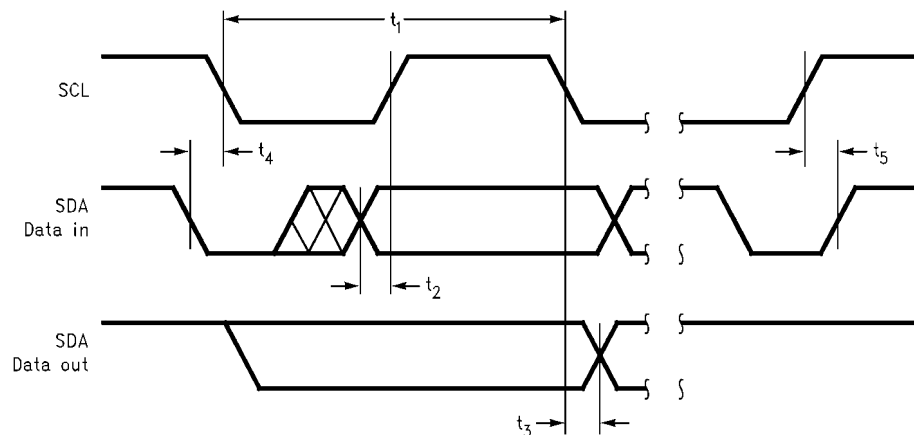

30068467

FIGURE 2. I²C Timing Diagram

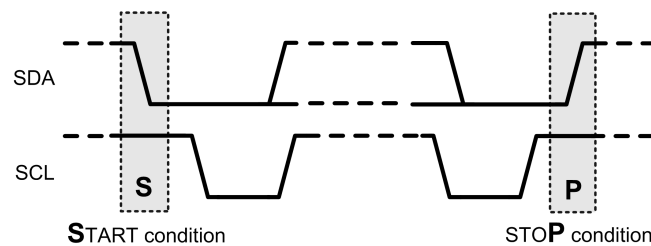

300684g8

FIGURE 3. Start and Stop Diagram

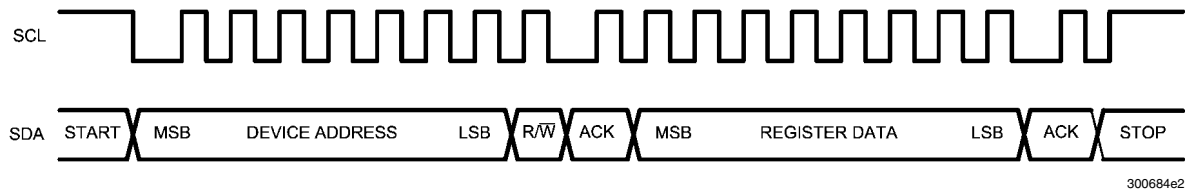

FIGURE 4. Example Write Sequence

TABLE 2. Device Address

	B7	B6	B5	B4	B3	B2	B1	B0 R/W
Chip Address	1	1	1	0	1	1	0	0

TABLE 3. Mode Control Registers

Register Name	B7	B6	B5	B4	B3	B2	B1	B0
Mode Control	VOL4	VOL3	VOL2	VOL1	VOL0	0	ENABLE_A	ENABLE_B

GENERAL AMPLIFIER FUNCTION

The LM48823 is a ceramic speaker driver that utilizes National's inverting charge pump technology to deliver over $15V_{P-P}$ to a $2.2\mu F$ ceramic speaker while operating from a single 4.2V supply. The LM48823 features a unique input stage that converts two single-ended audio signals into a mono BTL output. This stereo to mono conversion is useful in applications where a stereo audio source is driving a single ceramic speaker, such as a ringer on a cellular phone. Connect INA and INB as shown in Figure 5 for the stereo-to-mono conversion. When the LM48823 is used with a single-ended mono audio source, connect both INA and INB to the audio source as shown in Figure 6.

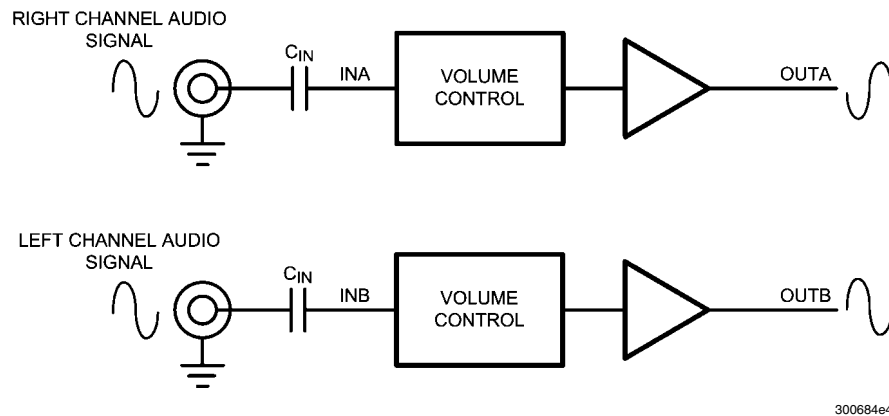

FIGURE 5. Stereo to Mono Conversion Connection Example

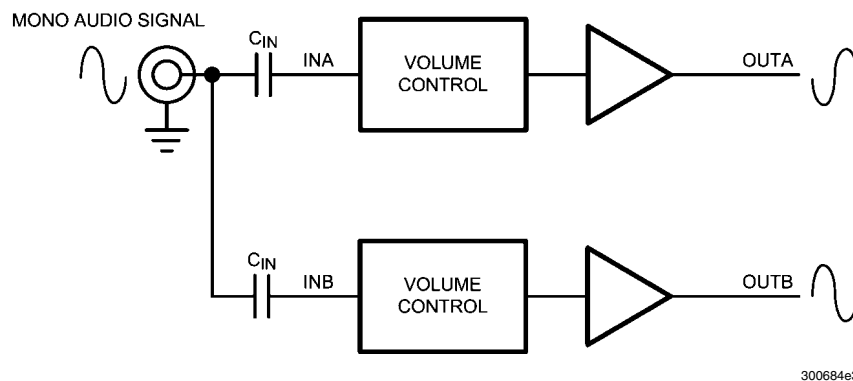

FIGURE 6. Mono Audio Source Connection Example

VOLUME CONTROL

TABLE 4. Volume Control

Volume Step	VOL4	VOL3	VOL2	VOL1	VOL0	Gain (dB)
1	0	0	0	0	0	-70
2	0	0	0	0	1	-56
3	0	0	0	1	0	-46
4	0	0	0	1	1	-38
5	0	0	1	0	0	-32
6	0	0	1	0	1	-28
7	0	0	1	1	0	-24
8	0	0	1	1	1	-21
9	0	1	0	0	0	-18
10	0	1	0	0	1	-15
11	0	1	0	1	0	-12
12	0	1	0	1	1	-10
13	0	1	1	0	0	-8
14	0	1	1	0	1	-6
15	0	1	1	1	0	-4
16	0	1	1	1	1	-2
17	1	0	0	0	0	0
18	1	0	0	0	1	2
19	1	0	0	1	0	4
20	1	0	0	1	1	6
21	1	0	1	0	0	8
22	1	0	1	0	1	10
23	1	0	1	1	0	12
24	1	0	1	1	1	16
25	1	1	0	0	0	14
26	1	1	0	0	1	15
27	1	1	0	1	0	16
28	1	1	0	1	1	17
29	1	1	1	0	0	18
30	1	1	1	0	1	22
31	1	1	1	1	0	23
32	1	1	1	1	1	24

SHUTDOWN FUNCTION

The LM48823 features a low-power shutdown mode that disables the device, lowering the quiescent current to 0.01µA. Set bits B1 (ENABLE_A) and B2 (ENABLE_B) to 0 to disable the amplifiers and charge pump. Set both ENABLE_A and ENABLE_B to 1 for normal operation. Shutdown mode does not clear the I²C register. When re-enabled, the device returns to its previous volume setting. To clear the I²C register, either remove power from the device, or toggle $\overline{\text{RESET}}$ (see $\overline{\text{RESET}}$ section).

RESET

The LM48823 features an active low reset input. Driving $\overline{\text{RESET}}$ low clears the I²C register. Volume control is set to 00000 (-70dB) and both ENABLE_A and ENABLE_B are set to 0, disabling the device. While $\overline{\text{RESET}}$ is low, the LM48823 ignores any I²C data. After the device is reset, and $\overline{\text{RESET}}$ is driven high, the LM48823 remains in shutdown mode with the volume set to -70dB. Re-enable the device by writing to the I²C register.

PROPER SELECTION OF EXTERNAL COMPONENTS

Power Supply Bypassing/Filtering

Proper power supply bypassing is critical for low noise performance and high PSRR. Place the supply bypass capacitors as close to the device as possible. Place a 1µF ceramic capacitor from V_{DD} to GND. Additional bulk capacitance may be added as required.

Bypass Capacitor Selection

The BYPASS capacitor, C_{BYPASS}, improves PSRR, noise rejection and output offset. For best results, use a capacitor of identical value to the input coupling capacitors

Charge Pump Capacitor Selection

Use low ESR ceramic capacitors (less than 100mΩ) for optimum performance.

Charge Pump Flying Capacitor (C1)

The flying capacitor (C1) affects the load regulation and output impedance of the charge pump. A C1 value that is too low

results in a loss of current drive, leading to a loss of amplifier headroom. A higher valued C1 improves load regulation and lowers charge pump output impedance to an extent. Above 2.2µF, the R_{DS(ON)} of the charge pump switches and the ESR of C1 and C2 dominate the output impedance. A lower value capacitor can be used in systems with low maximum output power requirements.

Charge Pump Hold Capacitor (C2)

The value and ESR of the hold capacitor (C2) directly affects the ripple on CPV_{SS}. Increasing the value of C2 reduces output ripple. Decreasing the ESR of C2 reduces both output ripple and charge pump output impedance. A lower value capacitor can be used in systems with low maximum output power requirements.

Input Capacitor Selection

Input capacitors block the DC component of the audio signal, eliminating any conflict between the DC component of the audio source and the bias voltage of the LM48823. The input capacitors create a high-pass filter with the input resistors R_{IN}. The -3dB point of the high pass filter is found using Equation (1) below.

$$f = 1 / 2\pi R_{IN} C_{IN} \quad (\text{Hz}) \quad (1)$$

Where the value of R_{IN} is given in the Electrical Characteristics Table.

High pass filtering the audio signal helps protect the speakers. When the LM48823 is using a single-ended source, power supply noise on the ground is seen as an input signal. Setting the high-pass filter point above the power supply noise frequencies, 217Hz in a GSM phone, for example, filters out the noise such that it is not amplified and heard on the output. Capacitors with a tolerance of 10% or better are recommended for impedance matching and improved CMRR and PSRR.

PCB Layout Guidelines

Minimize trace impedance of the power, ground and all output traces for optimum performance. Voltage loss due to trace resistance between the LM48823 and the load results in decreased output power and efficiency. Trace resistance between the power supply and ground has the same effect as a poorly regulated supply, increased ripple and reduced peak output power. Use wide traces for power supply inputs and amplifier outputs to minimize losses due to trace resistance, as well as route heat away from the device. Proper grounding

improves audio performance, minimizes crosstalk between channels and prevents switching noise from interfering with the audio signal. Use of power and ground planes is recommended.

Place all digital components and route digital signal traces as far as possible from analog components and traces. Do not run digital and analog traces in parallel on the same PCB layer. If digital and analog signal lines must cross either over or under each other, ensure that they cross in a perpendicular fashion.

LM48823TL Demoboard Bill of Materials

Designator	Quantity	Description
C1, C2	2	2.2 μ F \pm 10% 10V X5R Ceramic Capacitor (603) Panasonic ECJ-1VB1A225K Murata GRM033R6OJ104KE19D
C3 – C5	3	1 μ F \pm 10% 10V Tantalum Capacitor (402) AVX TACK105M010QTA
C6	1	4.7 μ F \pm 10% 6.3V X5R Ceramic Capacitor (603) Panasonic ECJ-1VB0J475K Murata GRM188R6OJ475KE19D
C7, C8	2	0.1 μ F \pm 10% 6.3V X5R Ceramic Capacitor (201) Panasonic ECJ-ZEB0J104K Murata GRM188R61A225KE34D
JU1 – JU5	5	2 Pin Header
JU6, JU7	3	2 Pin Header
J1	1	5-Pin I ² C Header
LM4823TL	1	LM48823TL (16-Bump microSMD)

PC Board Layout

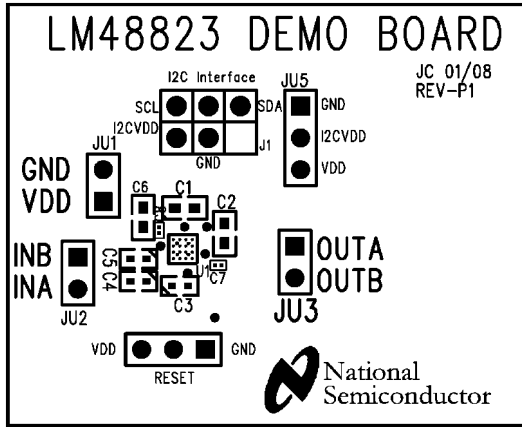

FIGURE 8: Top Silkscreen Layer

300684f0

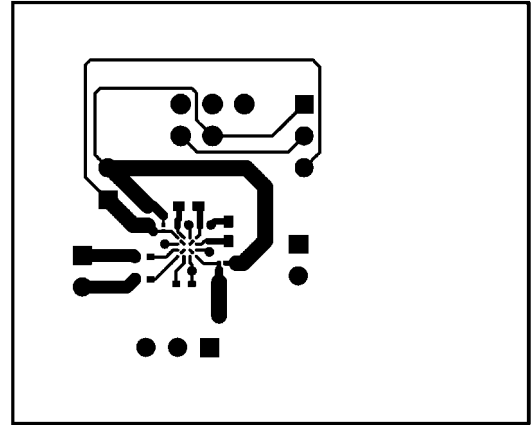

FIGURE 9: Top Layer

300684f1

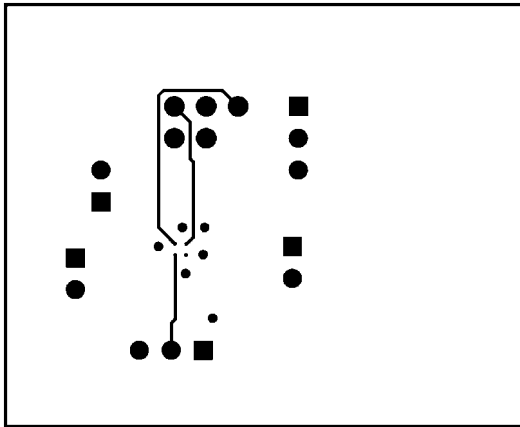

FIGURE 10: Layer 2

300684e7

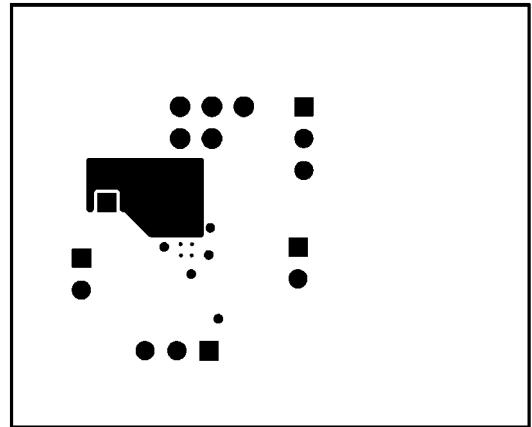

FIGURE 11: Layer 3

300684e8

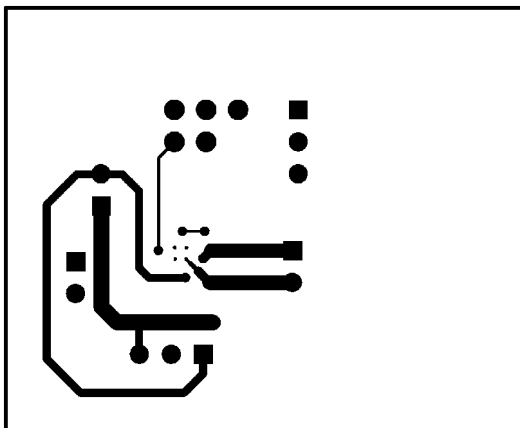

FIGURE 12: Bottom Layer

300684e6

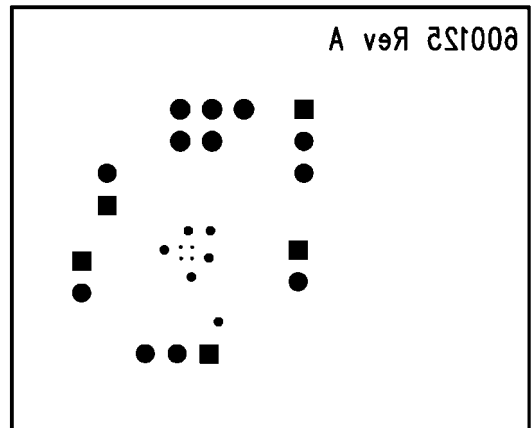

FIGURE 13: Bottom Silkscreen

300684e9

Revision History

Rev	Date	Description
1.0	06/27/08	Initial release.
1.01	07/15/08	Edited the Ordering Information table.

Physical Dimensions inches (millimeters) unless otherwise noted

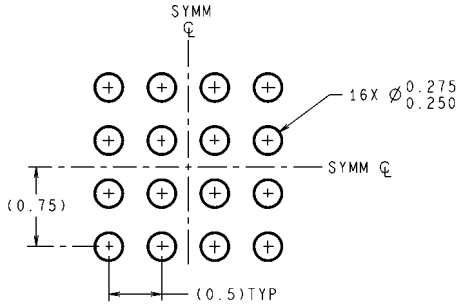

DIMENSIONS ARE IN MILLIMETERS
DIMENSIONS IN () FOR REFERENCE ONLY

LAND PATTERN RECOMMENDATION

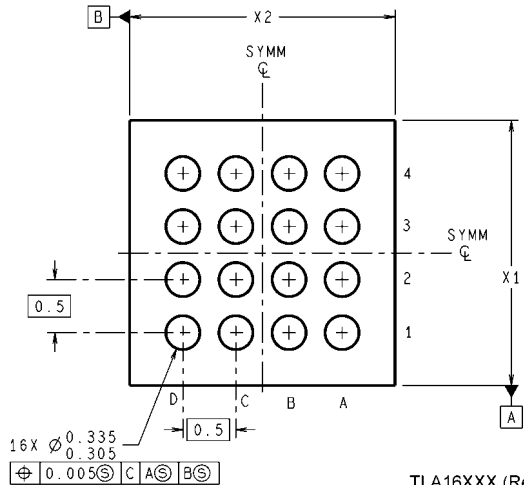
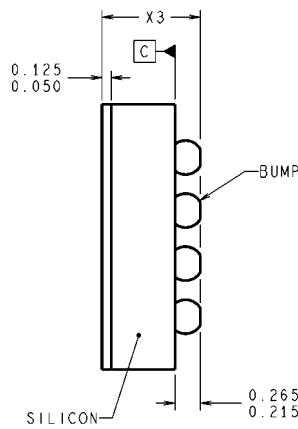
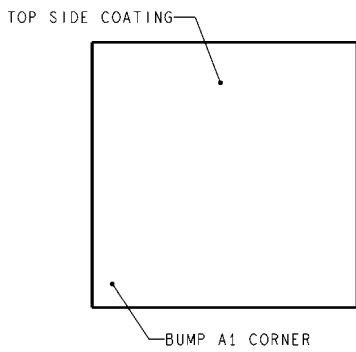

TLA16XXX (Rev C)

16-Bump micro SMD
Order Number LM48823TL
NS Package Number TLA1611A
 $X_1 = 1.970 \pm 0.03$ $X_2 = 1.970 \pm 0.03$ $X_3 = 0.6 \pm 0.075$

Notes

LM48823

Notes

For more National Semiconductor product information and proven design tools, visit the following Web sites at:

Products		Design Support	
Amplifiers	www.national.com/amplifiers	WEBENCH	www.national.com/webench
Audio	www.national.com/audio	Analog University	www.national.com/AU
Clock Conditioners	www.national.com/timing	App Notes	www.national.com/appnotes
Data Converters	www.national.com/adc	Distributors	www.national.com/contacts
Displays	www.national.com/displays	Green Compliance	www.national.com/quality/green
Ethernet	www.national.com/ethernet	Packaging	www.national.com/packaging
Interface	www.national.com/interface	Quality and Reliability	www.national.com/quality
LVDS	www.national.com/lvds	Reference Designs	www.national.com/refdesigns
Power Management	www.national.com/power	Feedback	www.national.com/feedback
Switching Regulators	www.national.com/switchers		
LDOs	www.national.com/lido		
LED Lighting	www.national.com/led		
PowerWise	www.national.com/powerwise		
Serial Digital Interface (SDI)	www.national.com/sdi		
Temperature Sensors	www.national.com/tempsensors		
Wireless (PLL/VCO)	www.national.com/wireless		

THE CONTENTS OF THIS DOCUMENT ARE PROVIDED IN CONNECTION WITH NATIONAL SEMICONDUCTOR CORPORATION ("NATIONAL") PRODUCTS. NATIONAL MAKES NO REPRESENTATIONS OR WARRANTIES WITH RESPECT TO THE ACCURACY OR COMPLETENESS OF THE CONTENTS OF THIS PUBLICATION AND RESERVES THE RIGHT TO MAKE CHANGES TO SPECIFICATIONS AND PRODUCT DESCRIPTIONS AT ANY TIME WITHOUT NOTICE. NO LICENSE, WHETHER EXPRESS, IMPLIED, ARISING BY ESTOPPEL OR OTHERWISE, TO ANY INTELLECTUAL PROPERTY RIGHTS IS GRANTED BY THIS DOCUMENT.

TESTING AND OTHER QUALITY CONTROLS ARE USED TO THE EXTENT NATIONAL DEEMS NECESSARY TO SUPPORT NATIONAL'S PRODUCT WARRANTY. EXCEPT WHERE MANDATED BY GOVERNMENT REQUIREMENTS, TESTING OF ALL PARAMETERS OF EACH PRODUCT IS NOT NECESSARILY PERFORMED. NATIONAL ASSUMES NO LIABILITY FOR APPLICATIONS ASSISTANCE OR BUYER PRODUCT DESIGN. BUYERS ARE RESPONSIBLE FOR THEIR PRODUCTS AND APPLICATIONS USING NATIONAL COMPONENTS. PRIOR TO USING OR DISTRIBUTING ANY PRODUCTS THAT INCLUDE NATIONAL COMPONENTS, BUYERS SHOULD PROVIDE ADEQUATE DESIGN, TESTING AND OPERATING SAFEGUARDS.

EXCEPT AS PROVIDED IN NATIONAL'S TERMS AND CONDITIONS OF SALE FOR SUCH PRODUCTS, NATIONAL ASSUMES NO LIABILITY WHATSOEVER, AND NATIONAL DISCLAIMS ANY EXPRESS OR IMPLIED WARRANTY RELATING TO THE SALE AND/OR USE OF NATIONAL PRODUCTS INCLUDING LIABILITY OR WARRANTIES RELATING TO FITNESS FOR A PARTICULAR PURPOSE, MERCHANTABILITY, OR INFRINGEMENT OF ANY PATENT, COPYRIGHT OR OTHER INTELLECTUAL PROPERTY RIGHT.

LIFE SUPPORT POLICY

NATIONAL'S PRODUCTS ARE NOT AUTHORIZED FOR USE AS CRITICAL COMPONENTS IN LIFE SUPPORT DEVICES OR SYSTEMS WITHOUT THE EXPRESS PRIOR WRITTEN APPROVAL OF THE CHIEF EXECUTIVE OFFICER AND GENERAL COUNSEL OF NATIONAL SEMICONDUCTOR CORPORATION. As used herein:

Life support devices or systems are devices which (a) are intended for surgical implant into the body, or (b) support or sustain life and whose failure to perform when properly used in accordance with instructions for use provided in the labeling can be reasonably expected to result in a significant injury to the user. A critical component is any component in a life support device or system whose failure to perform can be reasonably expected to cause the failure of the life support device or system or to affect its safety or effectiveness.

National Semiconductor and the National Semiconductor logo are registered trademarks of National Semiconductor Corporation. All other brand or product names may be trademarks or registered trademarks of their respective holders.

Copyright© 2008 National Semiconductor Corporation

For the most current product information visit us at www.national.com



**National Semiconductor
Americas Technical
Support Center**
Email: support@nsc.com
Tel: 1-800-272-9959

**National Semiconductor Europe
Technical Support Center**
Email: europe.support@nsc.com
German Tel: +49 (0) 180 5010 771
English Tel: +44 (0) 870 850 4288

**National Semiconductor Asia
Pacific Technical Support Center**
Email: ap.support@nsc.com

**National Semiconductor Japan
Technical Support Center**
Email: jpn.feedback@nsc.com