



LP2950/2951

LINEAR INTEGRATED CIRCUIT

100 mA LOW-DROPOUT VOLTAGE REGULATOR

DESCRIPTION

The UTC **LP2950/2951** are monolithic integrated voltage regulators with low dropout voltage, and low quiescent current. It includes many features that suitable for different applications.

FEATURES

- * Fixed output versions, 2.5V, 3V, 3.3V, 3.6V and 5V, are available.
- * High accuracy output voltage.
- * Extremely low quiescent current and dropout voltage.
- * Extremely tight load and line regulation.
- * Current and thermal limiting.
- * Very low temperature coefficient.
- * Logic controlled shutdown and err flog available for 8 pin package.
- * Output voltage programmable for LP2951.

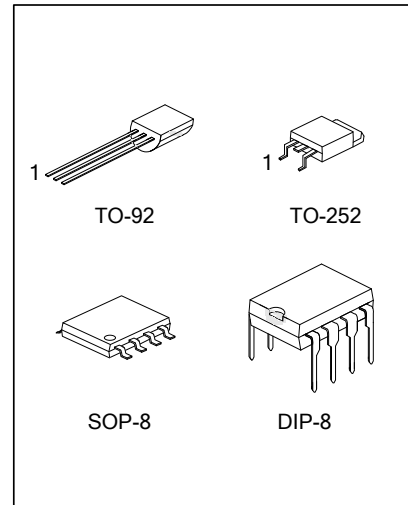

*Pb-free plating product number:
LP2950L-XX/LP2951L

ORDERING INFORMATION

Ordering Number		Package	Packing
Normal	Lead Free Plating		
LP2950-xx-D08-T	LP2950L-xx-D08-T	DIP-8	Tube
LP2950-xx-S08-T	LP2950L-xx-S08-T	SOP-8	Tube
LP2950-xx-S08-R	LP2950L-xx-S08-R	SOP-8	Tape Reel
LP2950-xx-T92-B	LP2950L-xx-T92-B	TO-92	Tape Box
LP2950-xx-T92-K	LP2950L-xx-T92-K	TO-92	Bulk
LP2950-xx-TN3-T	LP2950L-xx-TN3-T	TO-252	Tube
LP2950-xx-TN3-R	LP2950L-xx-TN3-R	TO-252	Tape Reel
LP2951-D08-T	LP2951L-D08-T	DIP-8	Tube
LP2951-S08-T	LP2951L-S08-T	SOP-8	Tube
LP2951-S08-R	LP2951L-S08-R	SOP-8	Tape Reel

Note: Pin Assignment: I:V_{IN} O:V_{OUT} G:GND

<p>LP2950L-xx-S08-R</p> <p>(1)Packing Type (2)Package Type (3)Output Voltage Code (4)Lead Plating</p>	<p>(1) B: Tape Box, K: Bulk, R: Tape Reel, T: Tube (2) D08: DIP-8, S08: SOP-8, T92: TO-92 TN3: TO-252 (3) xx: refer to Output Voltage Code (4) L: Lead Free Plating, Blank: Pb/Sn</p>
---	---

OUTPUT VOLTAGE CODE(For LP2950)

OUTPUT VOLTAGE	CODE
2.5V	25
3.0V	30
3.3V	33
3.6V	36
5.0V	50

LP2950/2951

LINEAR INTEGRATED CIRCUIT

PIN CONFIGURATIONS

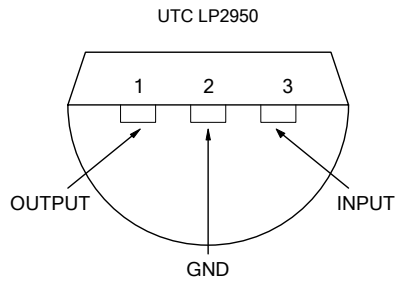

TO-92 Plastic Package Bottom View

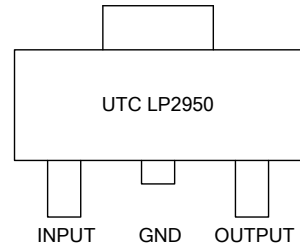

SOT-252 Package

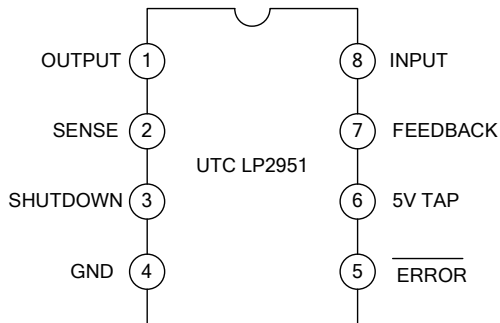

SOP-8 OR DIP-8 PACKAGE FOR UTC LP2951

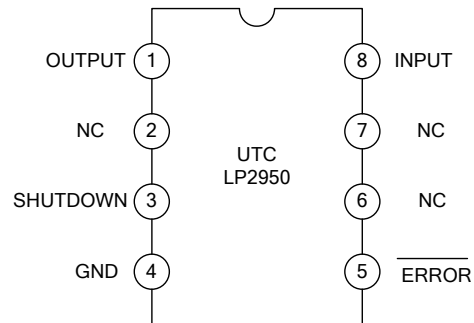

SOP-8 OR DIP-8 PACKAGE FOR UTC LP2950

BLOCK DIAGRAM

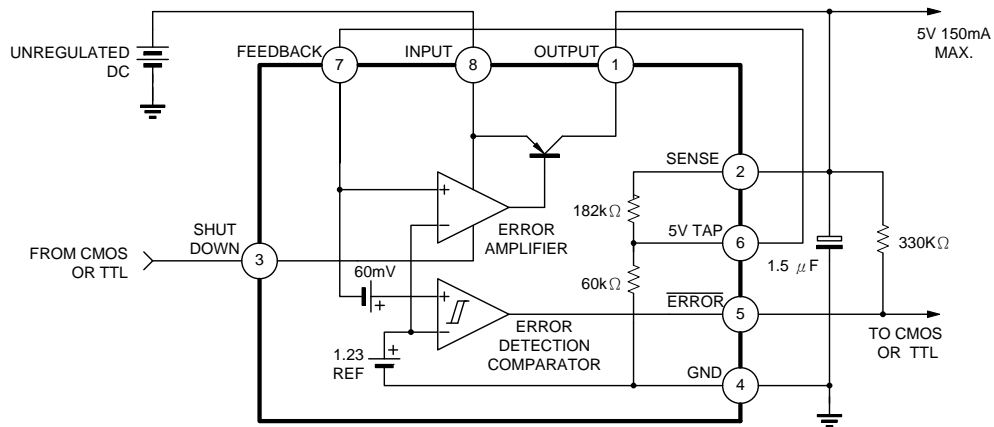

FOR UTC LP2951

■ ABSOLUTE MAXIMUM RATINGS

PARAMETER	SYMBOL	RATINGS	UNIT
Supply Voltage	V_{CC}	-0.3 ~ +30	V
Feedback Voltage	V_{FB}	-1.5 ~ +30	V
Shutdown Voltage	V_{SHDN}	-0.3 ~ +30	V
Operation Junction Temperature	T_J	-40 ~ +125	°C
Storage Temperature	T_{STG}	-65 ~ +150	°C

Note: Absolute maximum ratings are those values beyond which the device could be permanently damaged. Absolute maximum ratings are stress ratings only and functional device operation is not implied.

■ ELECTRICAL CHARACTERISTICS ($T_J=25^\circ\text{C}$, $V_{IN}=6\text{V}$, $I_L=100\mu\text{A}$, $C_L=1\mu\text{F}$, unless otherwise specified.)

For All Version:

PARAMETER	SYMBOL	TEST CONDITION	MIN	TYP	MAX	UNIT
Output Voltage	V_{OUT}	$T_J=25^\circ\text{C}$ (Note 1)	$V_{OUT}\times 0.98$	V_{OUT}	$V_{OUT}\times 1.02$	V
		$-25^\circ\text{C}\leq T_J\leq +85^\circ\text{C}$ (Note 1)	$V_{OUT}\times 0.98$	V_{OUT}	$V_{OUT}\times 1.02$	V
Output Voltage	V_{OUT}	$100\mu\text{A}\leq I_L\leq 100\text{mA}$, $T_J\leq T_J(\text{max})$	$V_{OUT}\times 0.98$	V_{OUT}	$V_{OUT}\times 1.02$	V
Output Voltage Temperature Coefficient	TcV_o		20		100	ppm/°C
Line Regulation	ΔV_{OUT}	$6\text{V}\leq V_{IN}\leq 30\text{V}$	0.03	0.1	0.2	%
Load Regulation	ΔV_{OUT}	$100\mu\text{A}\leq I_L\leq 100\text{mA}$	0.04	0.1	0.2	%
Dropout Voltage	V_D	$I_L=100\mu\text{A}$	50	80	150	mV
		$I_L=100\text{mA}$ (Note 2)	380	450	600	mV
Ground Current	I_G	$I_L=100\mu\text{A}$	75	120	140	μA
		$I_L=100\text{mA}$	8	12	14	mA
Dropout Ground Current		$V_{IN}=4.5\text{V}$, $I_L=100\mu\text{A}$	110	170	200	μA
Current Limit	I_{LIMIT}	$V_{OUT}=0$	160	200	220	mA
Output Noise (10Hz ~ 100KHz) (Bypass=0.01 μF pins 7 to 1 (LP2951))	eN	$C_L=1\mu\text{F}$			430	μV
		$C_L=200\mu\text{F}$			160	μV
		$C_L=3.3\mu\text{F}$			100	μV

For UTC LP2951 8-Pin Version Only

PARAMETER	SYMBOL	TEST CONDITION	MIN	TYP	MAX	UNIT
Reference Voltage	V_{REF}		1.22	1.235	1.25	V
Reference Voltage	V_{REF}	Over temperature (Note 4)	1.19		1.27	V
Feedback pin Bias Current	I_{FB}			20	40	nA
Reference Voltage Temperature Coefficient	$V_{REF(TC)}$			50		ppm/°C
Feedback Bias Current Temperature Coefficient	$I_{FB(TC)}$			0.1		nA/°C
Error Comparator						
Output Leakage Current	$I_{O(LEAK)}$	$V_{OH}=30\text{V}$			1	μA
Output Low Voltage	V_{OL}	$V_{IN}=4.5\text{V}$, $I_{OL}=400\mu\text{A}$			250	mV
Threshold Voltage	Upper	V_{THU} (Note 3)	3.2			%VO
	Lower	V_{THL} (Note 3)			7.6	%VO
Hysteresis	V_{HYS}	(Note 3)		15		mV

■ ELECTRICAL CHARACTERISTICS(Cont.)

For UTC LP2951 8-Pin Version Only

PARAMETER	SYMBOL	TEST CONDITION	MIN	TYP	MAX	UNIT	
Shutdown Input							
Input Logic Voltage	Low	V_{IL}	Regulator ON		1.3	0.70	V
	High	V_{IH}	Regulator OFF	2.0			
Shutdown Pin Input Current	I_{SHDN}		$V_{SHDN}=2.4V$		30	50	μA
			$V_{SHDN}=30V$		450	600	μA
Regulator Output Current Shutdown	I_{DFF}		$V_{SHDN} \geq 2V, V_{IN} \leq 30V, V_{OUT}=0$ Feedback pin tied to 5V Tap.		3	10	μA

Note 1: Additional conditions for 8-pin versions are FB pin tied to $5V_{TAP}$, Output tied to Sense ($V_{OUT}=5V$) and $V_{SHDN} \leq 0.8V$.

Note 2: Dropout Voltage is defined as the input to output differential at which the output voltage drops 100mV below its nominal value measured at 1V differential.

Note 3: Comparator thresholds are expressed in terms of percentage value of voltage output.

Note 4: $V_{REF} \leq V_{OUT} \leq (V_{IN}-1V)$, $2.3V \leq V_{IN} \leq 30V$, $100\mu A \leq I_L \leq 100mA$, $T_J \leq T_{J(MAX)}$

■ TYPICAL APPLICATION CIRCUIT
10 Ampere Low Dropout Regulator

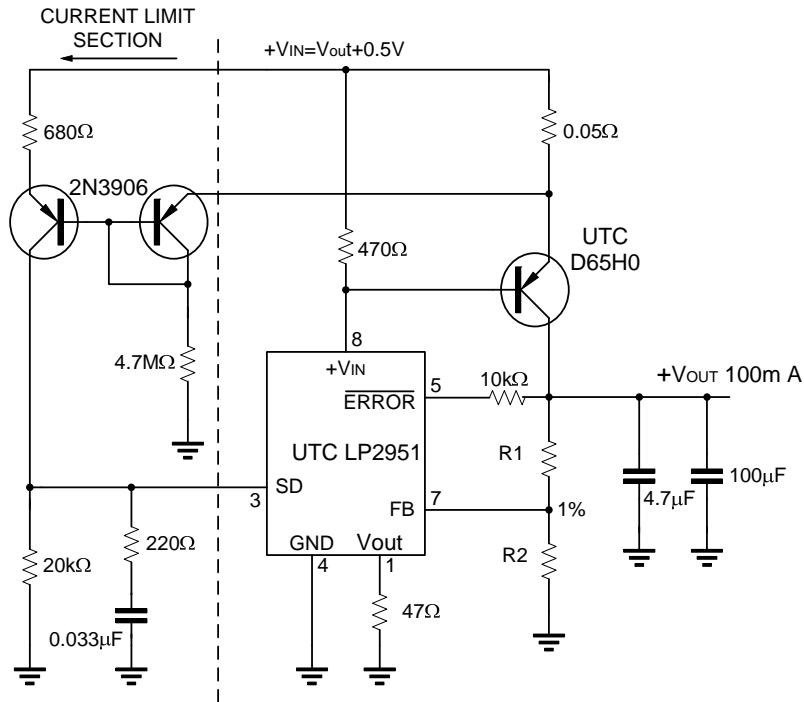

$$V_{OUT} = 1.23V * (1 + R1/R2)$$

For 5V output use internal resistors. Wire pin 6 to 7 and wire pin 2 to +Vout

Fig.1

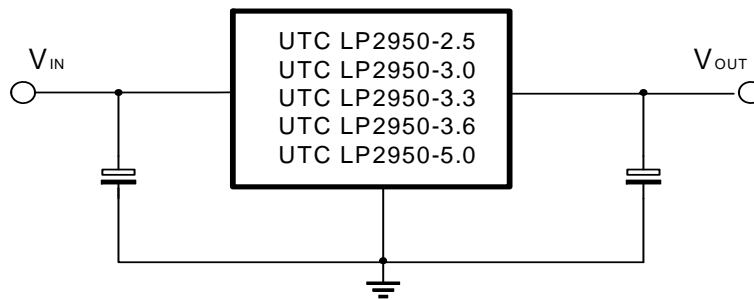
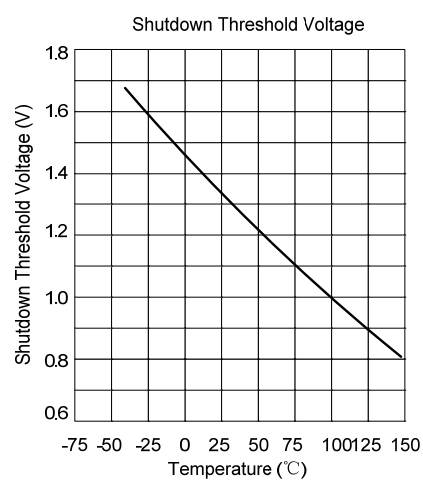
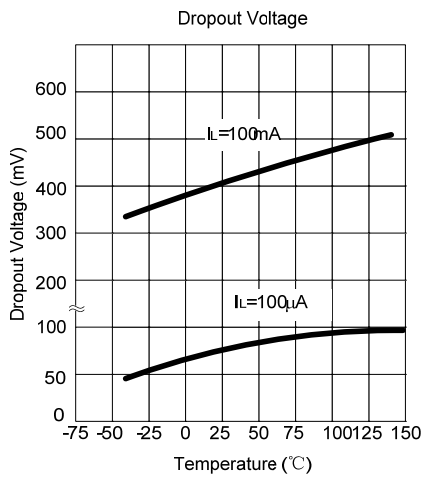
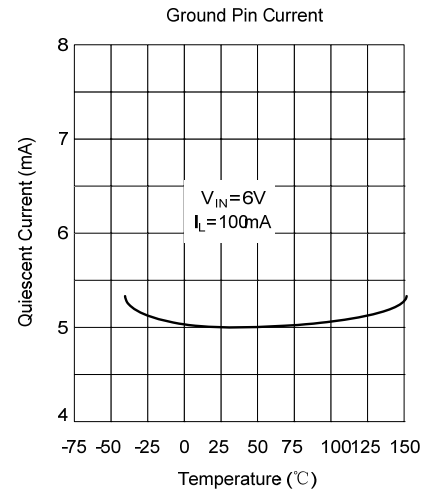
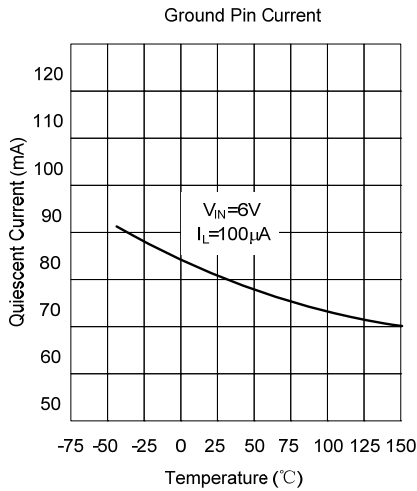
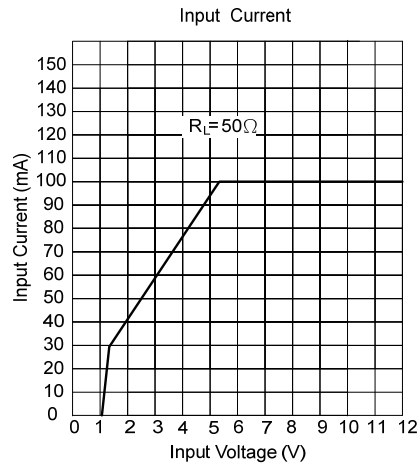
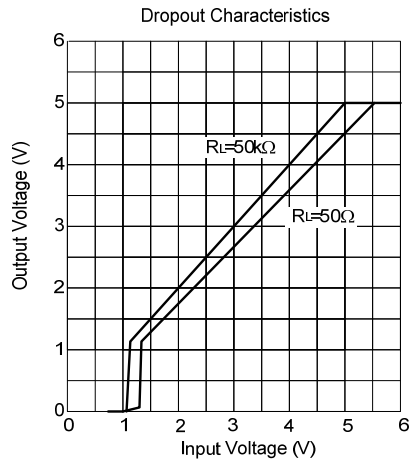
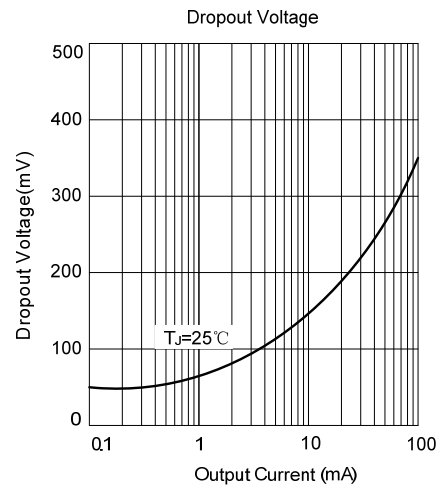
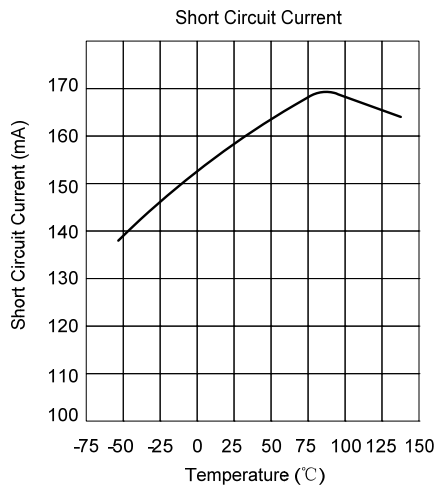

Fig.2

■ TYPICAL CHARACTERISTICS



■ TYPICAL CHARACTERISTICS(Cont.)



UTC assumes no responsibility for equipment failures that result from using products at values that exceed, even momentarily, rated values (such as maximum ratings, operating condition ranges, or other parameters) listed in products specifications of any and all UTC products described or contained herein. UTC products are not designed for use in life support appliances, devices or systems where malfunction of these products can be reasonably expected to result in personal injury. Reproduction in whole or in part is prohibited without the prior written consent of the copyright owner. The information presented in this document does not form part of any quotation or contract, is believed to be accurate and reliable and may be changed without notice.