

TA7510S

EARTH LEAK BREAKER

FEATURES

- High Sensibility : $V_{Trip} = 7mV$ (Typ.)
- Compose of Toshiba Original SIP (7Pin) so that it is possible to manufacture very small Earth Leak Breaker by using this device.
- Having High Reliability for the swing of supply voltage.
- Be possible to turn on External Thyristor Because of having Regulator Circuit.
- Having stability Trip Voltage Value.
- High Speed Rising Time.

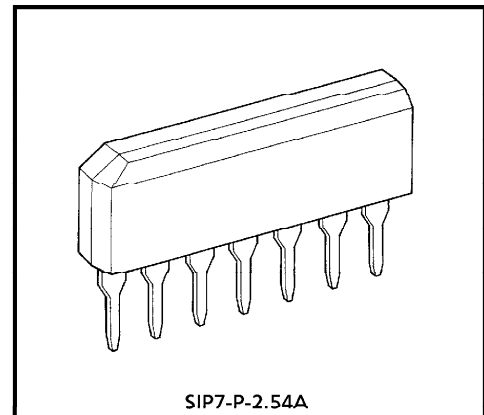

Weight : 0.7g (Typ.)

BLOCK DIAGRAM

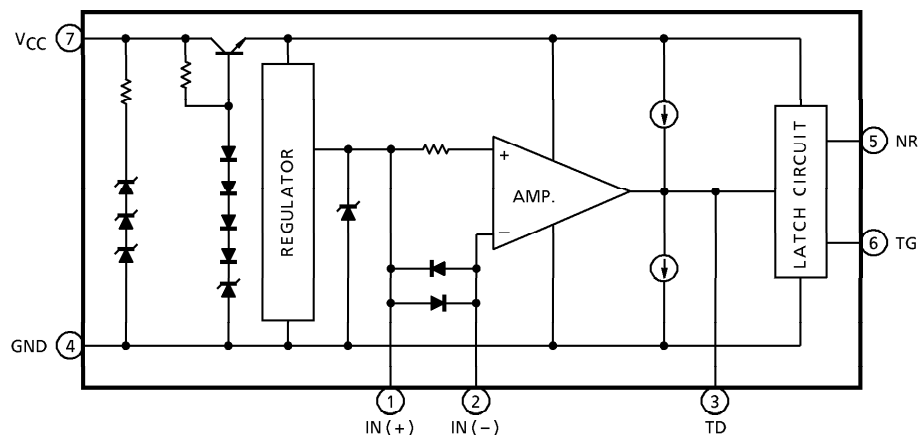

961001EBA2

- TOSHIBA is continually working to improve the quality and the reliability of its products. Nevertheless, semiconductor devices in general can malfunction or fail due to their inherent electrical sensitivity and vulnerability to physical stress. It is the responsibility of the buyer, when utilizing TOSHIBA products, to observe standards of safety, and to avoid situations in which a malfunction or failure of a TOSHIBA product could cause loss of human life, bodily injury or damage to property. In developing your designs, please ensure that TOSHIBA products are used within specified operating ranges as set forth in the most recent products specifications. Also, please keep in mind the precautions and conditions set forth in the TOSHIBA Semiconductor Reliability Handbook.
- The products described in this document are subject to foreign exchange and foreign trade control laws.
- The information contained herein is presented only as a guide for the applications of our products. No responsibility is assumed by TOSHIBA CORPORATION for any infringements of intellectual property or other rights of the third parties which may result from its use. No license is granted by implication or otherwise under any intellectual property or other rights of TOSHIBA CORPORATION or others.
- The information contained herein is subject to change without notice.

PIN CONNECTION

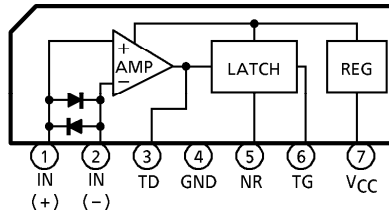

MAXIMUM RATINGS (Ta = 25°C)

CHARACTERISTIC	SYMBOL	CONDITION	RATING	UNIT
Supply Current	I_{CC}	—	10	mA
Input Current	I_{IM}	+ IN - (- IN)	250 (Note)	mA
		+ IN - GND	30	
		- IN - GND	30	
Power Dissipation	P_D	—	400	mW
Operating Temperature	T_{opr}	—	- 30~85	°C
Storage Temperature	T_{stg}	—	- 55~125	°C

(Note) In case the current between +IN and -IN, Pulse width must be less than 1ms.

ELECTRICAL CHARACTERISTICS (Ta = 25°C)

CHARACTERISTIC	SYMBOL	TEST CIR-CUIT	TEST CONDITION	MIN.	TYP.	MAX.	UNIT
Trip Voltage	VTRIP	1	V _{CC} = 16V, Ta = -30~85°C	4	—	10	mV
Supply Current (1)	I _{CC}	2	V _{CC} = 12V (+IN) - (-IN) = 30mV	—	550	900	μA
Gate Current	I _{TGH}	3	V _{CC} = 16V, V _{TG} = 0.8V Ta = 25°C	100	—	—	μA
			V _{CC} = 16V, V _{TG} = 0.8V Ta = -30~85°C	90	—	—	
Time Current	I _{TDH}	4	V _{CC} = 16V, V _{TD} = 0V	30	—	100	μA
TD Terminal "L" Current	I _{TDL}	5	V _{CC} = 16V, V _{TD} = 0.8V (+IN) - (-IN) Short	20	—	70	μA
ON Voltage Of Internal Latch Circuit	V _{ON (SCR)}	6	V _{CC} = 16V	0.7	—	1.6	V
Output "L" Current	I _{TGL}	7	V _{CC} = 12V, V _{TG} = 0.2V Ta = -30~85°C	100	—	—	μA
Input Clamp Voltage	V _{INC}	8	V _{CC} = 12V, I _{IN} = 30mA	4.6	—	6.9	V
Differential Input Clamp Voltage	V _{DFC}	9	I _{DF} = 100mA	0.7	—	1.3	V
V _{CC} Terminal Voltage	V _{CCM}	10	I = 10mA	22	—	30	V
Operating Supply Current (2)	I _{CC (ON)}	11	V _{CC} = 16V, V _{TG} = 0.8V Ta = -30~85°C	—	—	2.5	mA
Output "OFF" Supply Voltage	V _{CC (OFF)}	12	—	—	4.5	—	V
Operating Time	t _{ON}	13	V _{CC} = 16V (+IN) - (-IN) = 0.3V	—	1	—	ms

TEST CIRCUIT

1. Trip voltage V_{TRIP}

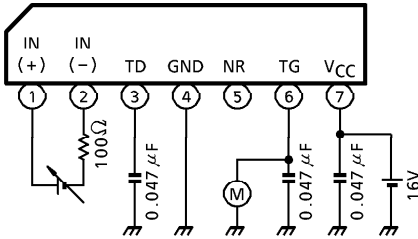

2. Supply current (1)

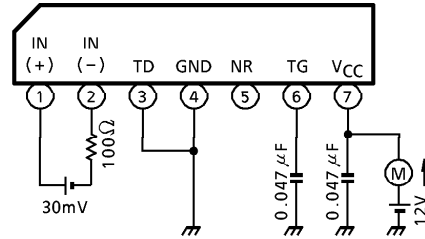

3. Gate current I_{TGH}

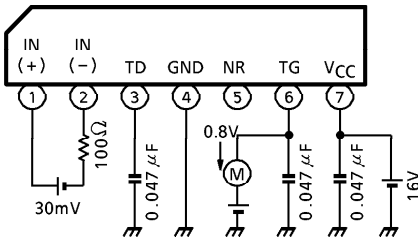

4. Time current I_{TDH}

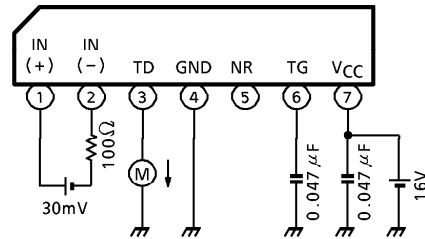

5. TD terminal "L" current I_{TDL}

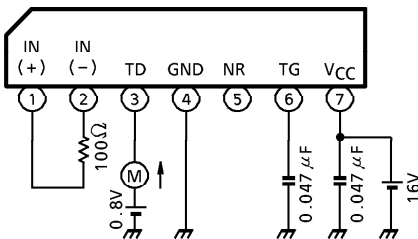

6. On voltage of internal latch circuit V_{ON} (SCR)

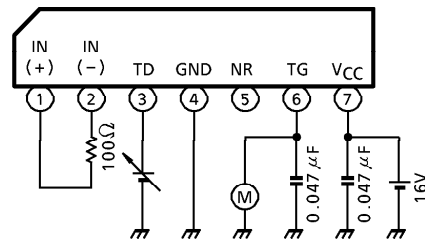

7. Output "L" current I_{TGL}

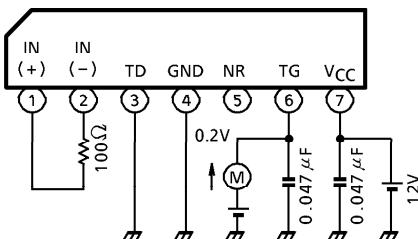

8. Input clamp voltage V_{INC}

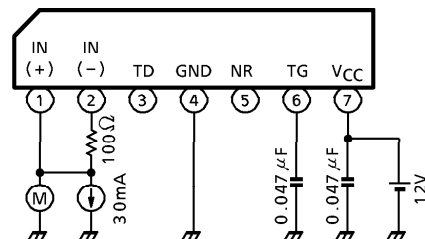

9. Differential input clamp voltage V_{DFC}

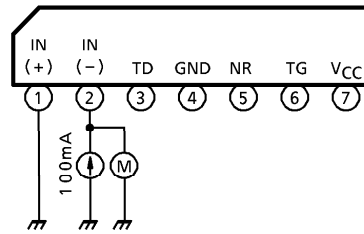
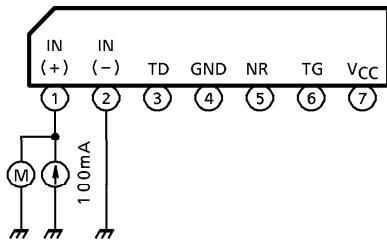

10. V_{CC} terminal voltage V_{CCM}

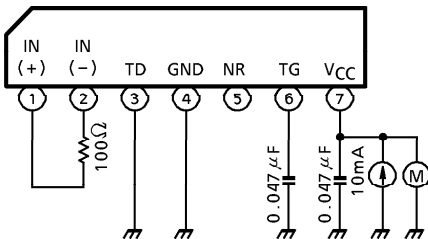

11. Operating current (2)

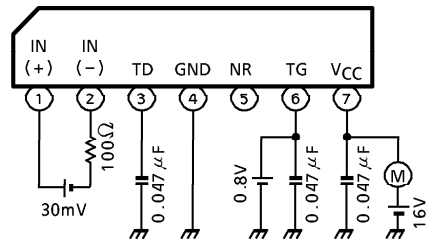

12. Latch "OFF" supply voltage $V_{CC(OFF)}$

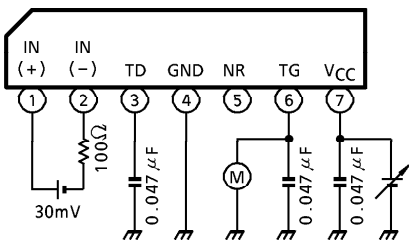

13. Operating time

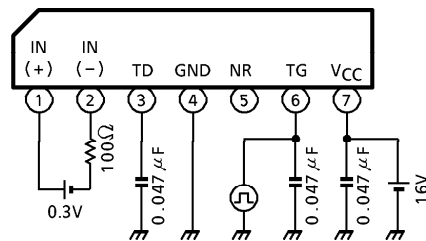

14. Latch operation

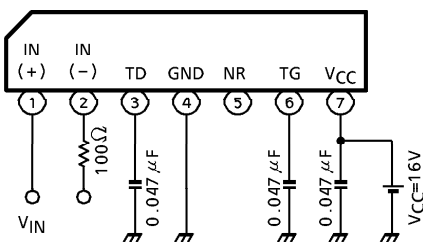

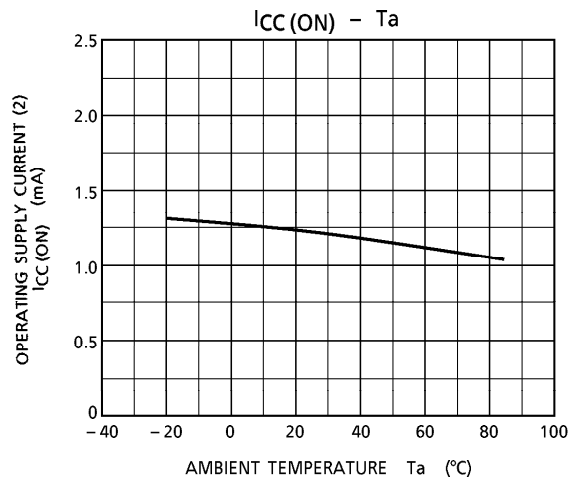
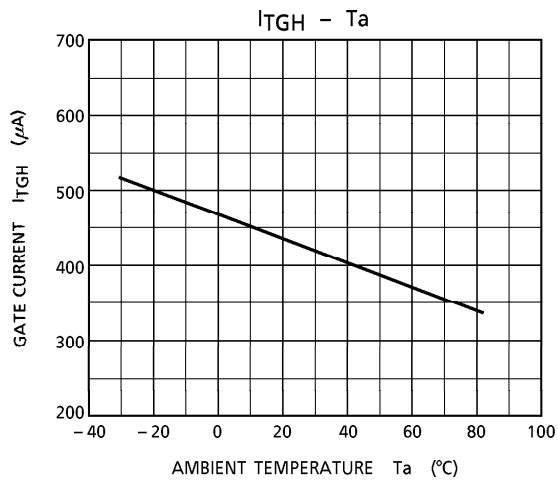
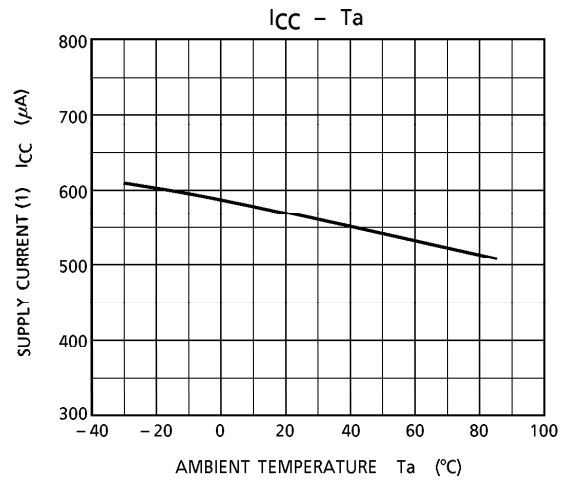
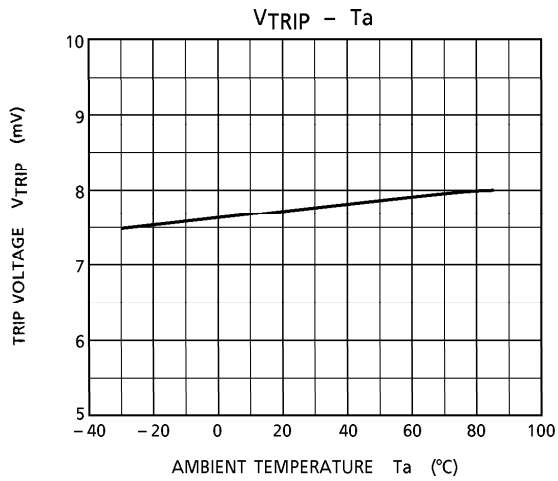

APPLICATION CIRCUIT (High speed earth leak breaker at 100V or 200V)

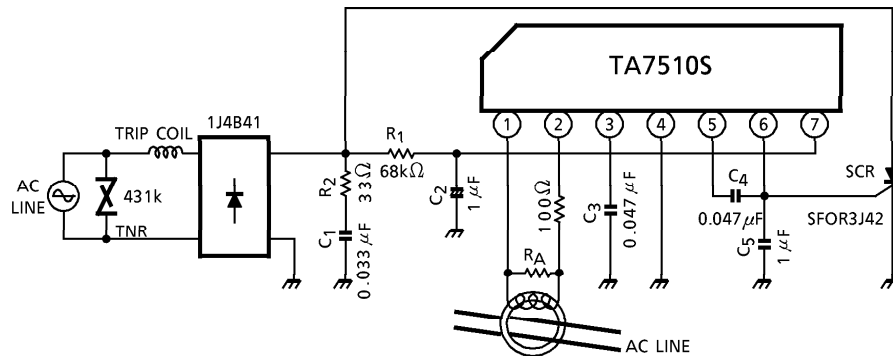

OUTLINE DRAWING
SIP7-P-2.54A

Unit : mm

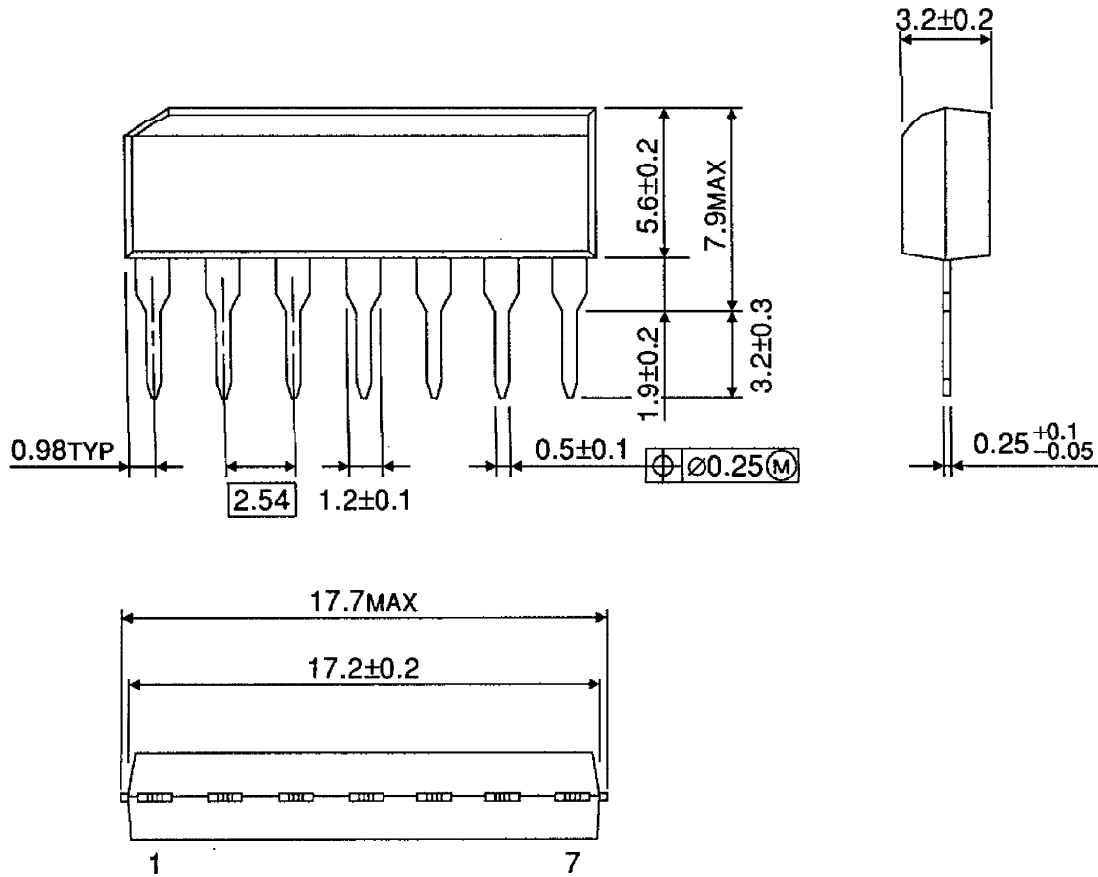

Weight : 0.7g (Typ.)