

TOSHIBA BIPOLAR LINEAR INTEGRATED CIRCUIT SILICON MONOLITHIC

# TA75557P, TA75557S, TA75557F

## DUAL OPERATIONAL AMPLIFIER

The TA75557P, TA75557S and TA75557F are Low-Noise Operational Amplifiers with High speed, Wide Bandwidth and High output Current.

It is High output Current with output circuit Improvement of TA75558P, TA75558S and TA75558F.

### FEATURES

- Internal Frequency Compensation Type
- Pin Compatible with TA75458P, TA75458S and TA75458F
- Possible to Exchange the Position of 9 Pin for 1 Pin Because of Pin Connection Being Symmetric (TA75557S Device Only)
- Wide Band Range :  $f = 3\text{MHz}$  (Typ.)
- Suitable Application for Active Filter, Equalizer Amp. and Headphone Amp.
- Output Current : 27mA (Min.)

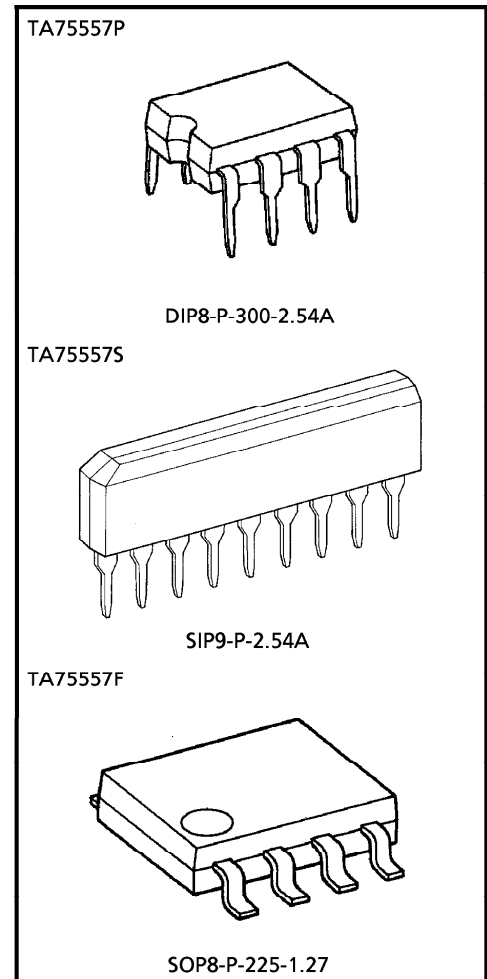

Weight  
 DIP8-P-300-2.54A : 0.5g (Typ.)  
 SIP9-P-2.54A : 0.9g (Typ.)  
 SOP8-P-225-1.27 : 0.1g (Typ.)

961001EBA1

- TOSHIBA is continually working to improve the quality and the reliability of its products. Nevertheless, semiconductor devices in general can malfunction or fail due to their inherent electrical sensitivity and vulnerability to physical stress. It is the responsibility of the buyer, when utilizing TOSHIBA products, to observe standards of safety, and to avoid situations in which a malfunction or failure of a TOSHIBA product could cause loss of human life, bodily injury or damage to property. In developing your designs, please ensure that TOSHIBA products are used within specified operating ranges as set forth in the most recent products specifications. Also, please keep in mind the precautions and conditions set forth in the TOSHIBA Semiconductor Reliability Handbook.
- The products described in this document are subject to foreign exchange and foreign trade control laws.
- The information contained herein is presented only as a guide for the applications of our products. No responsibility is assumed by TOSHIBA CORPORATION for any infringements of intellectual property or other rights of the third parties which may result from its use. No license is granted by implication or otherwise under any intellectual property or other rights of TOSHIBA CORPORATION or others.
- The information contained herein is subject to change without notice.

**PIN CONNECTION (TOP VIEW)**

TA75557F

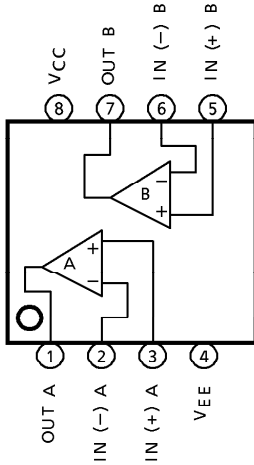

TA75557P

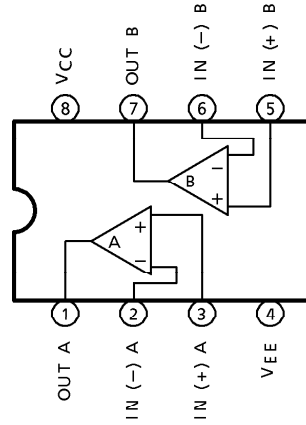

TA75557S

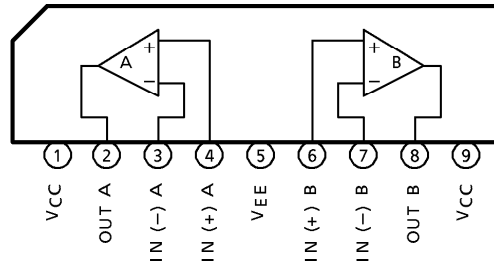

**EQUIVALENT CIRCUIT**

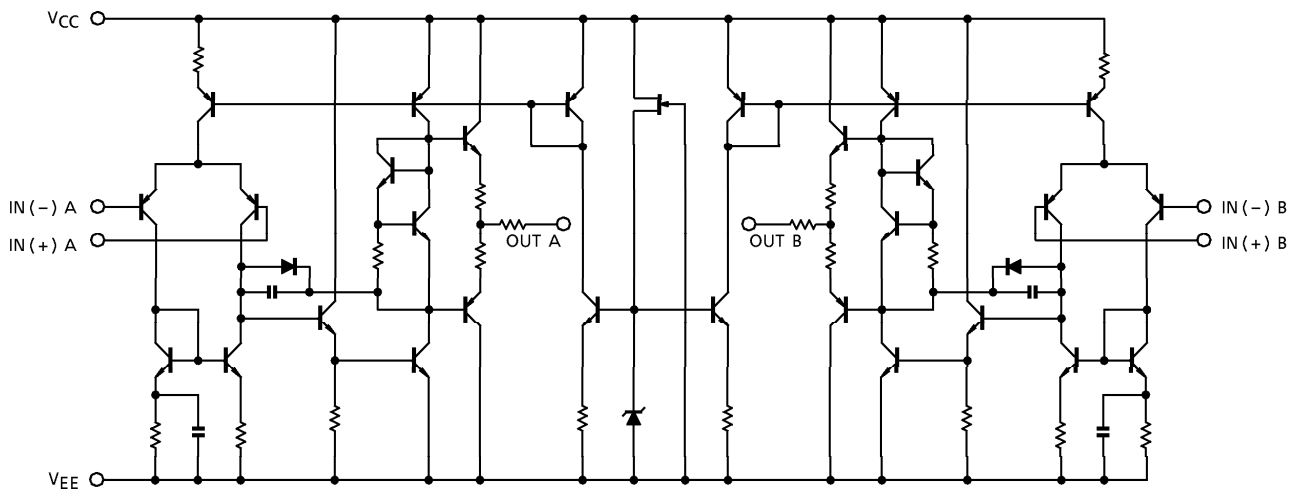

## MAXIMUM RATINGS (Ta = 25°C)

CHARACTERISTIC	SYMBOL	TA75557P TA75557S	TA75557F	UNIT
Supply Voltage	V <sub>CC</sub> , V <sub>EE</sub>	+ 18	+ 18	V
		- 18	- 18	
Differential Input Voltage	DV <sub>IN</sub>	± 30	± 30	V
Input Voltage	V <sub>IN</sub>	V <sub>CC</sub> ~V <sub>EE</sub>	V <sub>CC</sub> ~V <sub>EE</sub>	V
Power Dissipation	P <sub>D</sub>	500	240	mW
Operating Temperature	T <sub>opr</sub>	- 40~85	- 30~70	°C
Storage Temperature	T <sub>stg</sub>	- 55~125	- 55~125	°C

ELECTRICAL CHARACTERISTICS (V<sub>CC</sub> = 15V, V<sub>EE</sub> = - 15V, Ta = 25°C)

CHARACTERISTIC	SYMBOL	TEST CIRCUIT	TEST CONDITION	MIN.	TYP.	MAX.	UNIT
Input Offset Voltage	V <sub>IO</sub>	1	R <sub>g</sub> ≤ 10kΩ	—	0.5	6	mV
Input Offset Current	I <sub>IO</sub>	2	—	—	5	200	nA
Input Bias Current	I <sub>I</sub>	2	—	—	60	500	nA
Common Mode Input Voltage	CMV <sub>IN</sub>	3	—	± 12	± 14	—	V
Maximum Output Voltage	V <sub>OM</sub>	6	R <sub>L</sub> = 10kΩ	± 12	± 14	—	V
	V <sub>OMR</sub>		R <sub>L</sub> = 2kΩ	± 10	± 13	—	
Source Current	I <sub>source</sub>	8	—	27	—	—	mA
Sink Current	I <sub>sink</sub>	7	—	27	—	—	mA
Voltage Gain (Open Loop)	G <sub>V</sub>	5	V <sub>OUT</sub> = ± 10V, R <sub>L</sub> = 2kΩ	86	100	—	dB
Common Mode Input Signal Rejection Ratio	CMRR	3	R <sub>g</sub> ≤ 10kΩ	70	90	—	dB
Supply Voltage Rejection Ratio	SVRR	1	R <sub>g</sub> ≤ 10kΩ	—	30	150	μV/V
Slew Rate	SR	9	G <sub>V</sub> = 1, R <sub>L</sub> = 2kΩ	—	1.0	—	V/μs
Unity Gain Cross Frequency	f <sub>T</sub>	5	Open Loop	—	3.0	—	MHz
Supply Current	I <sub>CC</sub> , I <sub>EE</sub>	4	—	—	4.0	6.0	mA
Equivalent Input Noise Voltage	V <sub>NI</sub>	—	R <sub>S</sub> = 1kΩ, f = 30Hz~30kHz	—	2.5	—	μV <sub>rms</sub>

TEST CIRCUIT

(1)  $V_{IO}$ ,  $SVRR$

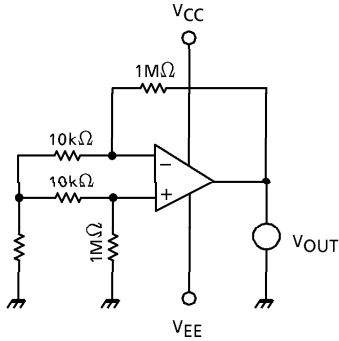

- $V_{IO} = V_{OUT} / 100$
- $SVRR = 20 \log E \text{ (dB)}$

$$E = \left| \frac{V_{OUT1} - V_{OUT2}}{(V_{CC1} - V_{EE1}) - (V_{CC2} - V_{EE2})} \right| \times \frac{1}{100}$$

$V_{OUT1}$  :  $V_{OUT}$  ( $V_{CC}$ ,  $V_{EE} = \pm 8V$ )

$V_{OUT2}$  :  $V_{OUT}$  ( $V_{CC}$ ,  $V_{EE} = \pm 18V$ )

$V_{CC1}$  :  $V_{CC} = -8V$

$V_{EE1}$  :  $V_{EE} = -8V$

$V_{CC2}$  :  $V_{CC} = +18V$

$V_{EE2}$  :  $V_{EE} = -18V$

(2)  $I_I$ ,  $I_{IO}$

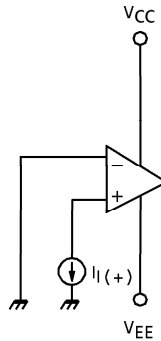
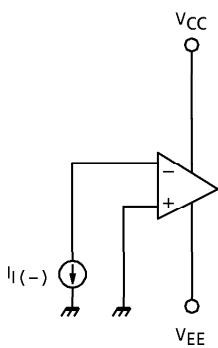

$$I_{IO} = |I_I(-) - I_I(+)|$$

(3)  $CMV_{IN}$ ,  $CMRR$

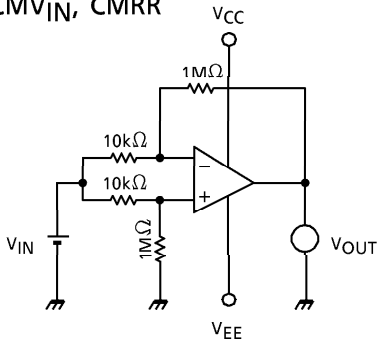

- $CMRR = 20 \log G_D / G_C \text{ (dB)}$
- $G_D$  : DIFFERENTIAL VOLTAGE GAIN
- $G_C$  : COMMON MODE VOLTAGE GAIN
- $CMV_{IN}$  :  $V_{IN} = -12V, 12V \text{ SUPPLIES}$

(4)  $I_{CC}$

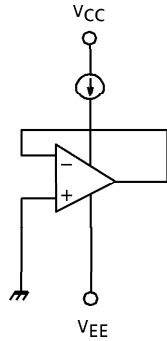

- $I_{CC} : V_{CC}, V_{EE} = \pm 15V$

(5)  $G_V, f_T$

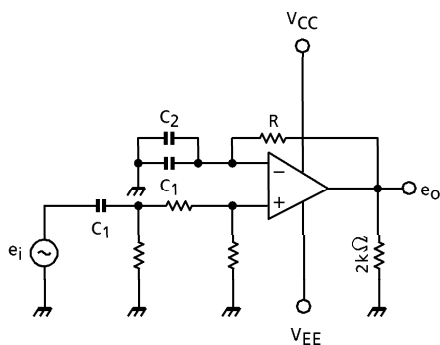

- $G_V = 20 \log e_o / e_i$  (dB)  
 $R \gg 1 / \omega C_1$   
 $C_1$  : COUPLING CONDENSER  
 $C_2$  : HIGH FREQUENCY BYPASS CONDENSER
- $f_T$  : INPUT FREQUENCY AT  $e_i = e_o$

(6)  $V_{OM}, V_{OMR}$

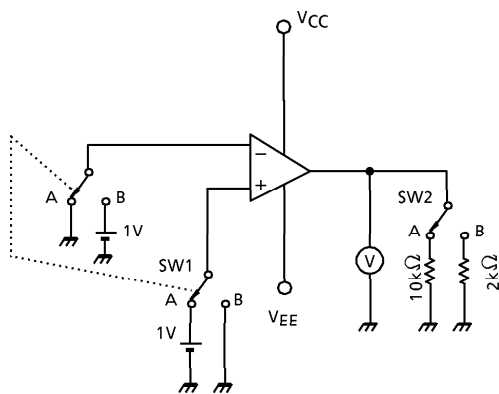

- $V_{OM} : (+) : SW1$  IS SIDE A,  $SW2$  IS SIDE A  
 $(-) : SW1$  IS SIDE B,  $SW2$  IS SIDE A
- $V_{OMR} : (+) : SW1$  IS SIDE A,  $SW2$  IS SIDE B  
 $(-) : SW1$  IS SIDE B,  $SW2$  IS SIDE B

(7)  $I_{sink}$

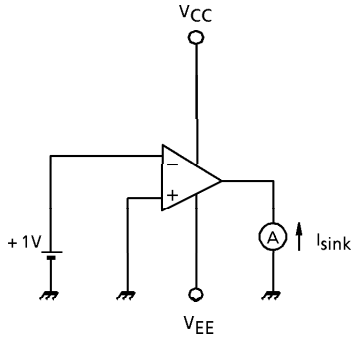

(8)  $I_{source}$

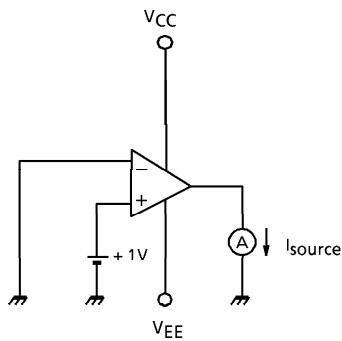

(9) SR

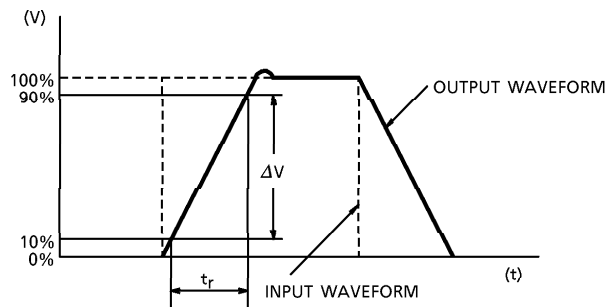
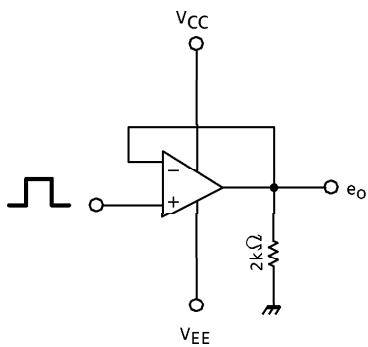

CHARACTERISTICS

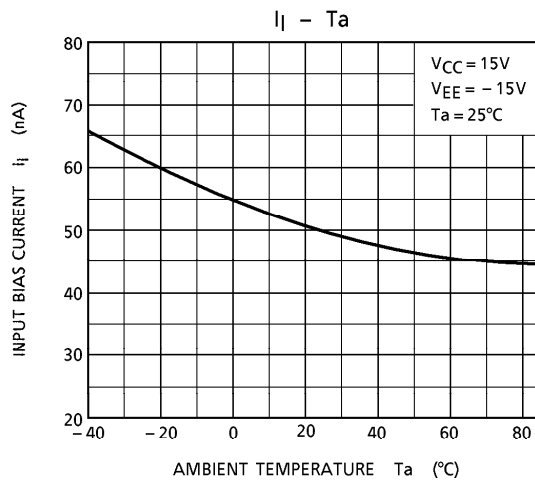
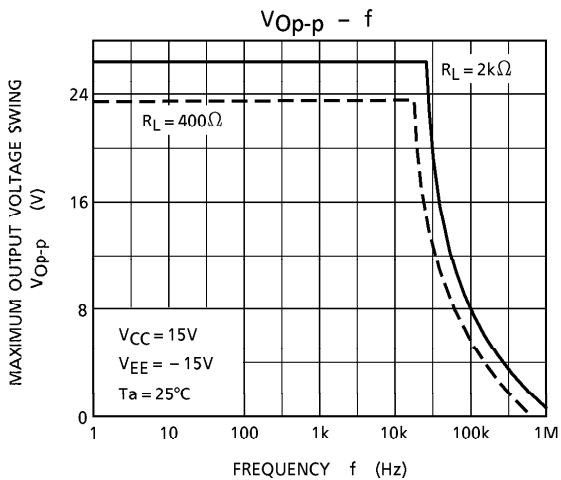
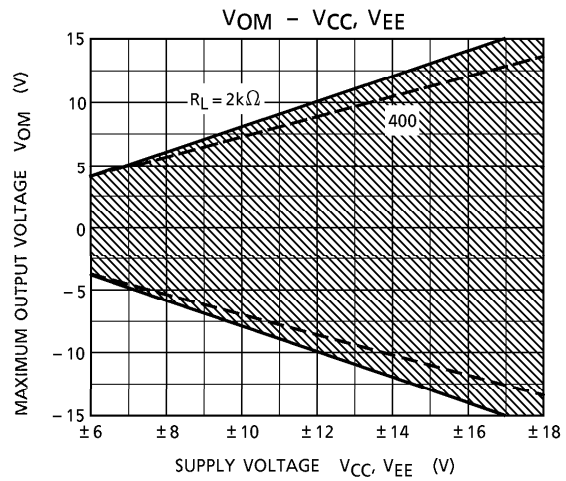
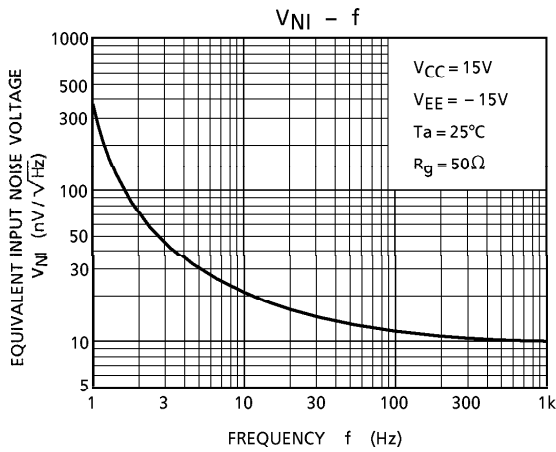
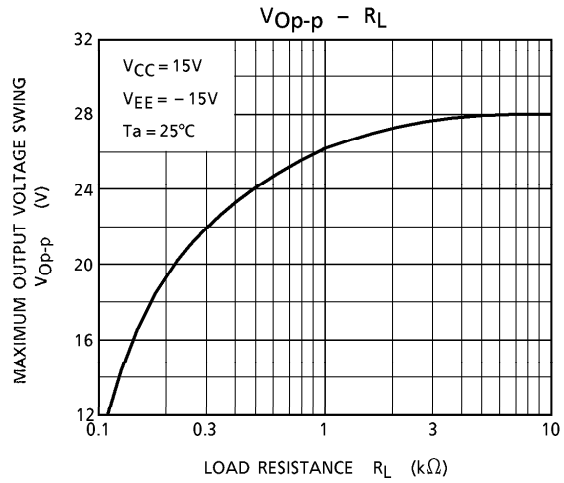
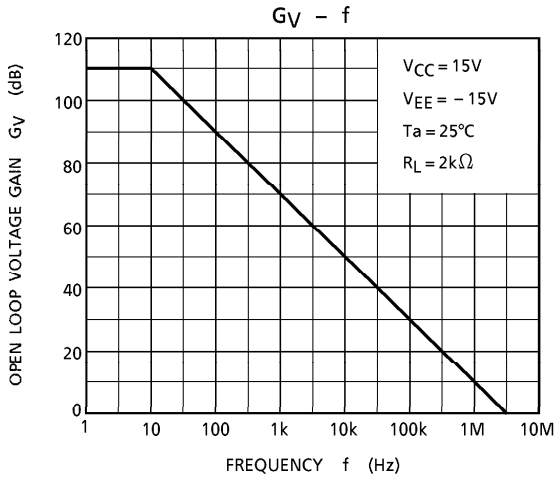

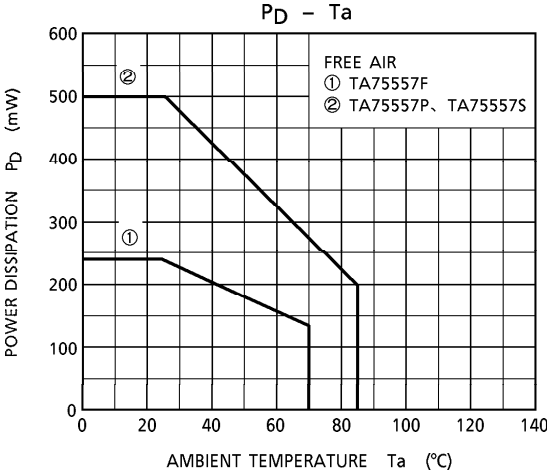



OUTLINE DRAWING  
DIP8-P-300-2.54A

Unit : mm

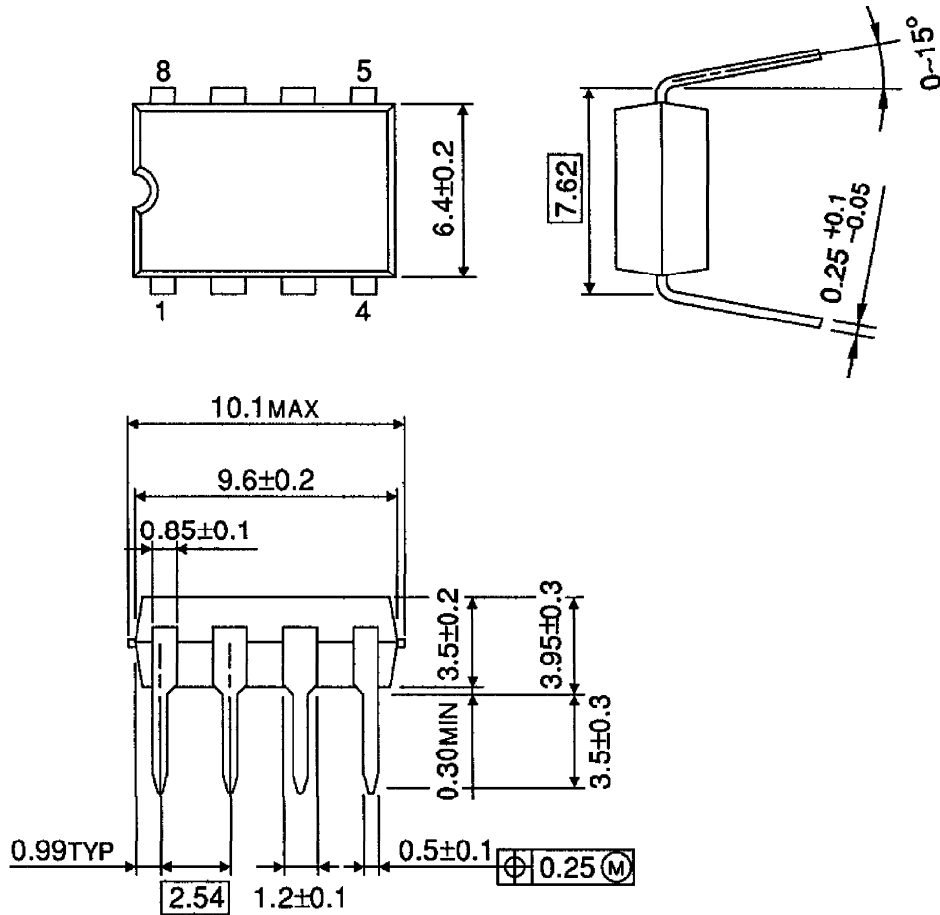

Weight : 0.5g (Typ.)

OUTLINE DRAWING  
SIP9-P-2.54A

Unit : mm

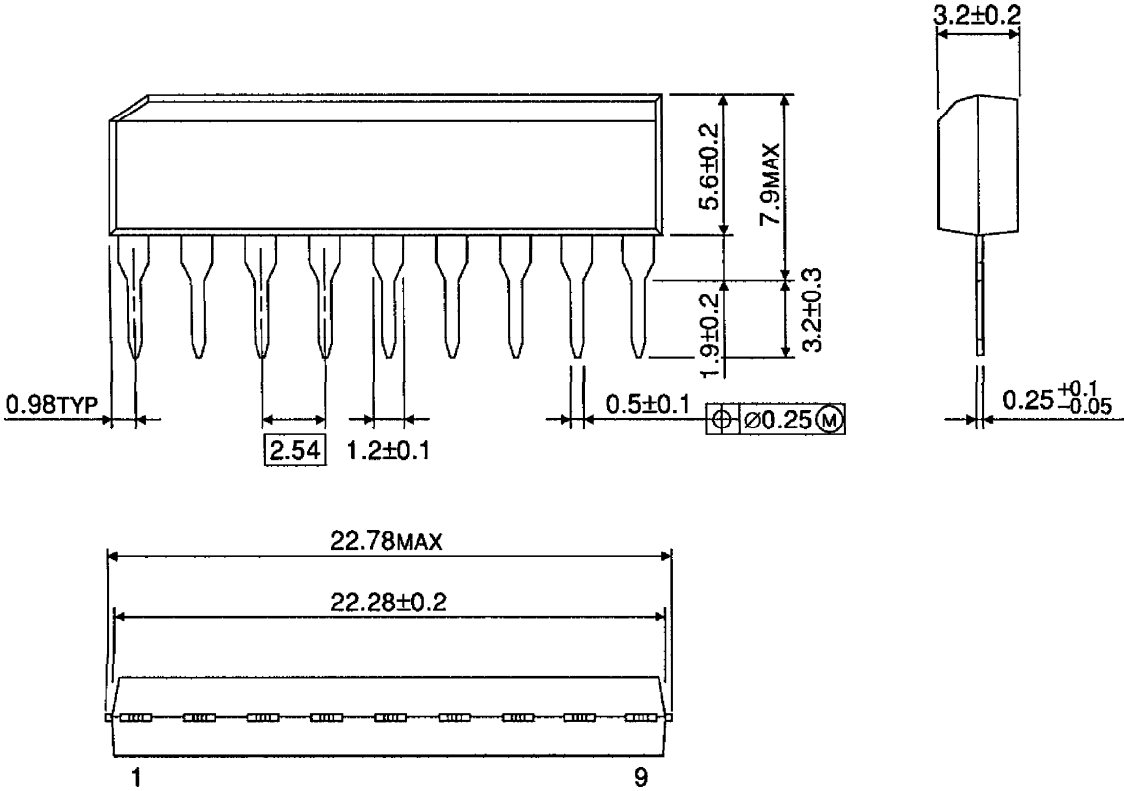

Weight : 0.9g (Typ.)

OUTLINE DRAWING  
SOP8-P-225-1.27

Unit : mm

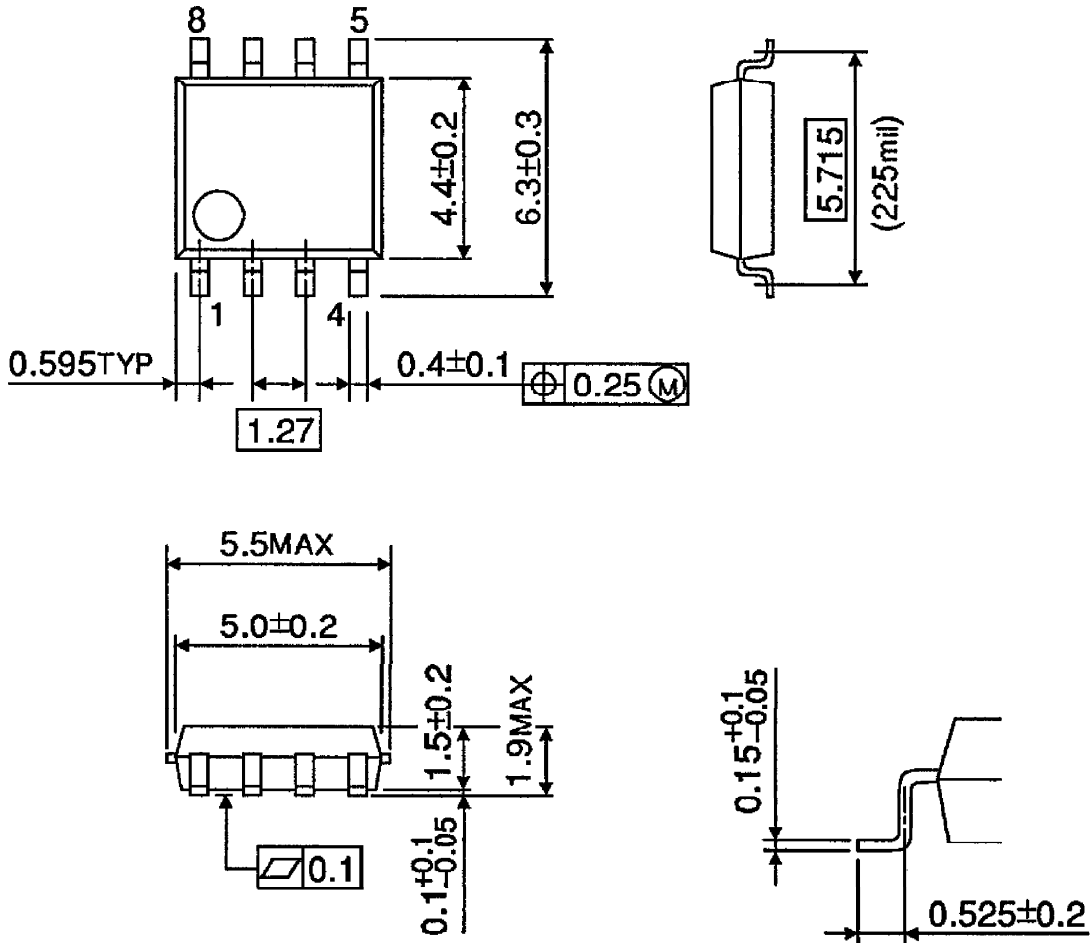

Weight : 0.1g (Typ.)