

**TA75393P, TA75393PA, TA75393S, TA75393F, TA75393FB**

**DUAL COMPARATOR**

This device consist of two independent voltage comparators that designed to operate from a single power supply over a wide range of voltage. Normal Operation from dual supplies is also to be guaranteed on voltage range from 2V to 36V.  $V_{CC}$  is necessary at least more 1.5V than the input common mode voltage. The output can be connected to other open collector outputs to achieve Wired-OR relation ship.

**FEATURES**

- Be possible to operate at the wide range single or two supply voltage.  
2~36V or  $\pm 1\sim 18V$
- Low supply current : 0.8mA (Typ.)
- Low input offset voltage :  $\pm 2mV$  (Typ.)
- Wide common mode input voltage :  $0\sim V_{CC} - 1.5V$
- Output is compatible with TTL, DTL, MOS and C-MOS.
- Output is open collector and wired-OR possible.

<b>Weight</b>	
DIP8-P-300-2.54A	: 0.5g (Typ.)
DIP8-P-300-2.54C	: 0.6g (Typ.)
SIP9-P-2.54A	: 0.9g (Typ.)
SOP8-P-225-1.27	: 0.1g (Typ.)
SOP8-P-225-1.27B	: 0.1g (Typ.)

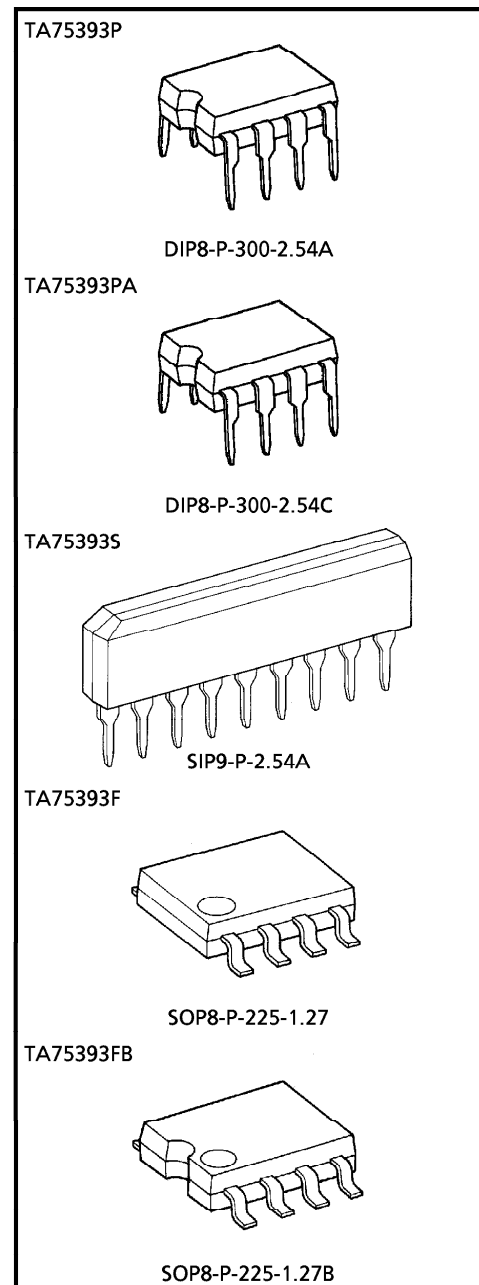

961001EBA1

● TOSHIBA is continually working to improve the quality and the reliability of its products. Nevertheless, semiconductor devices in general can malfunction or fail due to their inherent electrical sensitivity and vulnerability to physical stress. It is the responsibility of the buyer, when utilizing TOSHIBA products, to observe standards of safety, and to avoid situations in which a malfunction or failure of a TOSHIBA product could cause loss of human life, bodily injury or damage to property. In developing your designs, please ensure that TOSHIBA products are used within specified operating ranges as set forth in the most recent products specifications. Also, please keep in mind the precautions and conditions set forth in the TOSHIBA Semiconductor Reliability Handbook.

**PIN CONNECTION (TOP VIEW)**

TA75393F

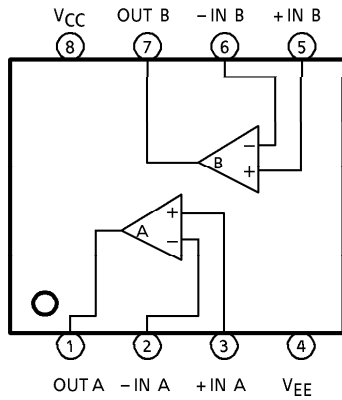

TA75393P, TA75393PA

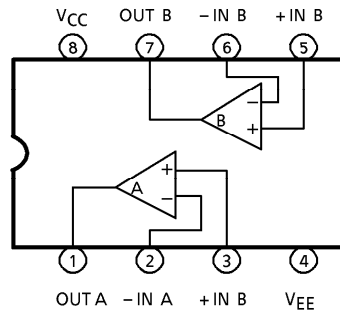

TA75393FB

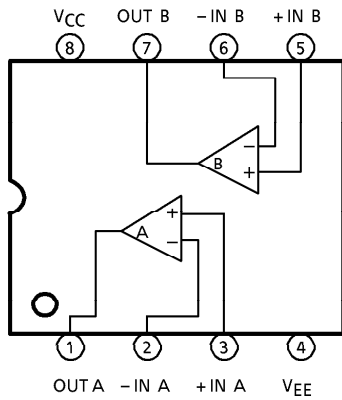

TA75393S

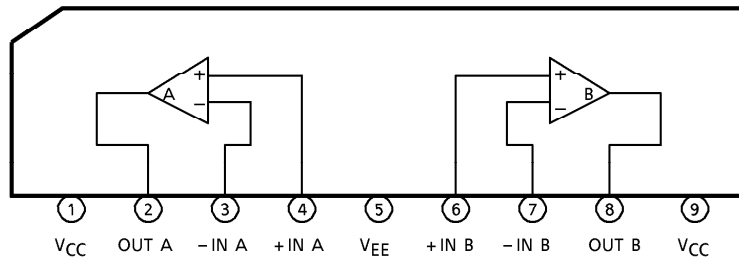

961001EBA1'

- The products described in this document are subject to foreign exchange and foreign trade control laws.
- The information contained herein is presented only as a guide for the applications of our products. No responsibility is assumed by TOSHIBA CORPORATION for any infringements of intellectual property or other rights of the third parties which may result from its use. No license is granted by implication or otherwise under any intellectual property or other rights of TOSHIBA CORPORATION or others.
- The information contained herein is subject to change without notice.

**EQUIVALENT CIRCUIT**

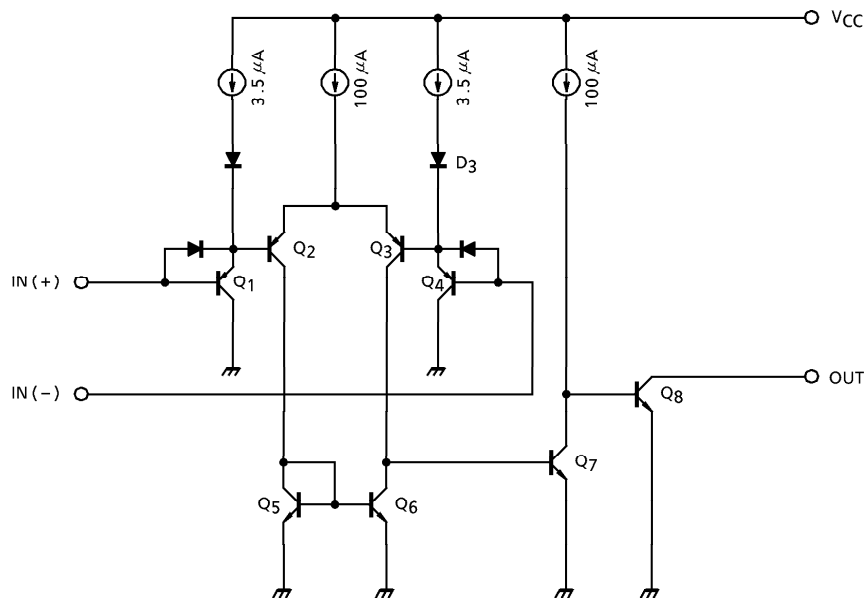

## MAXIMUM RATINGS (Ta = 25°C)

CHARACTERISTIC	SYMBOL	TA75393P TA75393PA TA75393S	TA75393F TA75393FB	UNIT
Supply Voltage	V <sub>CC</sub>	± 18 OR 36	± 18 OR 36	V
Differential Input Voltage	DV <sub>IN</sub>	± 36	± 36	V
Common Mode Input Voltage	CMV <sub>IN</sub>	- 0.3~V <sub>CC</sub>	- 0.3~V <sub>CC</sub>	V
Power Dissipation	P <sub>D</sub>	500	240	mW
Operating Temperature	T <sub>opr</sub>	- 40~85	- 40~85	°C
Storage Temperature	T <sub>stg</sub>	- 55~125	- 55~125	°C

ELECTRICAL CHARACTERISTICS (V<sub>CC</sub> = 5V, Ta = 25°C)

CHARACTERISTIC	SYMBOL	TEST CIRCUIT	TEST CONDITION	MIN.	TYP.	MAX.	UNIT
Input Offset Voltage	V <sub>IO</sub>	4	—	—	2	5	mV
Input Bias Current	I <sub>I</sub>	2	—	—	25	250	nA
Input Offset Current	I <sub>IO</sub>	2	—	—	5	50	nA
Common Mode Input Voltage	CMV <sub>IN</sub>	4	—	0	—	V <sub>CC</sub> - 1.5	V
Voltage Gain	G <sub>V</sub>	—	R <sub>L</sub> = 15kΩ	—	200	—	V / mV
Supply Current	I <sub>CC</sub>	1	No load	—	0.8	2	mA
Sink Current	I <sub>SINK</sub>	5	IN (+) = 0V, IN (-) = 1V V <sub>OL</sub> = 1.5V	6	16	—	mA
Output Voltage ("L" Level)	V <sub>OL</sub>	5	IN (+) = 0V, IN (-) = 1V I <sub>SINK</sub> = 3mA	—	0.2	0.4	V
Output Leak Current	I <sub>LEAK</sub>	3	IN (+) = 1V, IN (-) = 0V V <sub>O</sub> = 5V	—	0.1	—	nA
Response Time	t <sub>rsp</sub>	6	R <sub>L</sub> = 5.1kΩ, C <sub>L</sub> = 15pF	—	1.3	—	μs

TEST CIRCUIT

(1)  $I_{CC}$

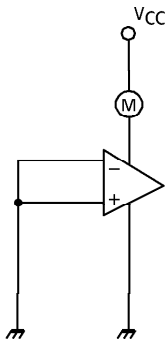

(2)  $I_I, I_{IO}$

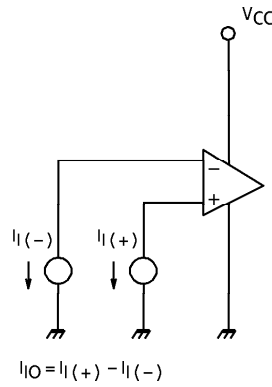

(3)  $I_{LEAK}$

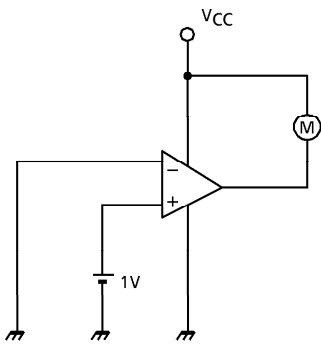

(4)  $V_{IO}, CMV_{IN}$

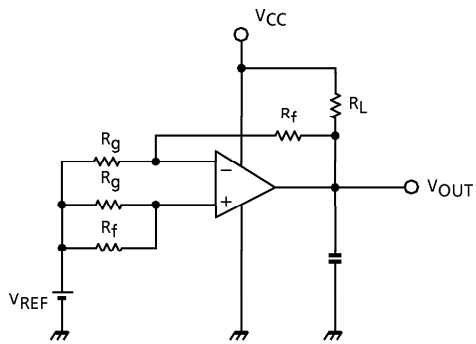

(5)  $I_{SINK}, V_{OL}$

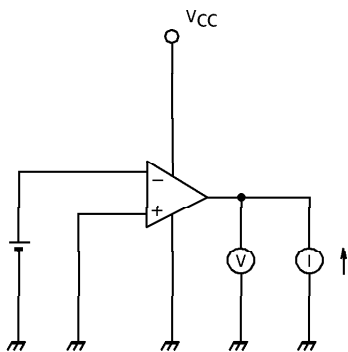

(6)  $t_{rsp}$

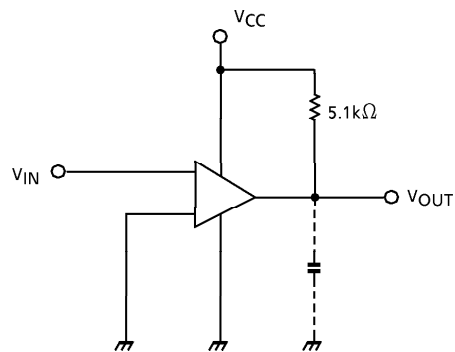

## CHARACTERISTICS

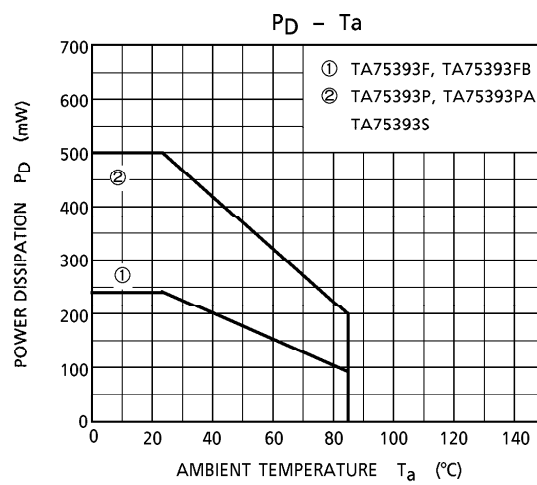
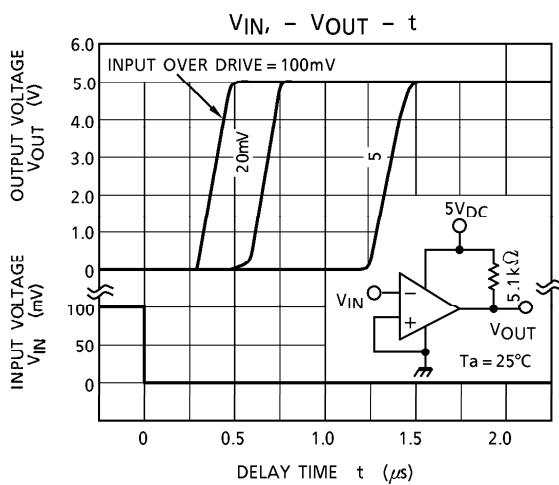
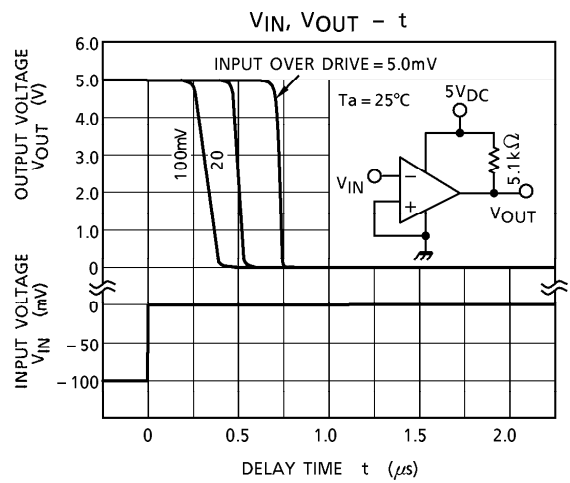
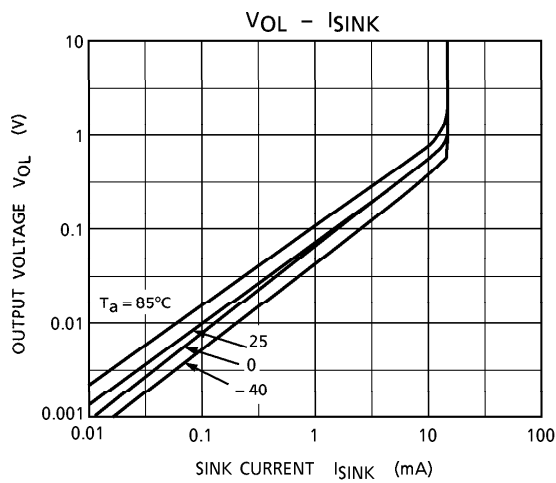
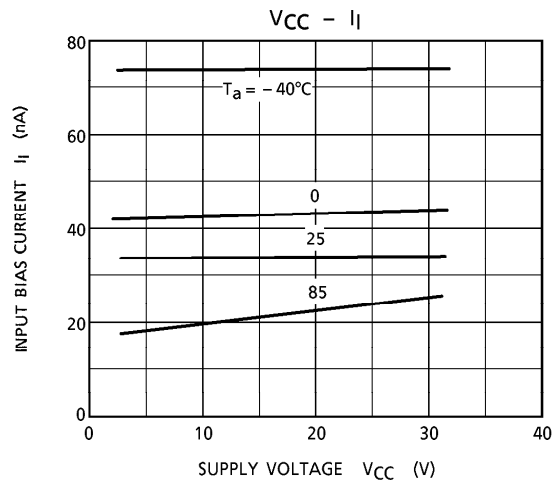
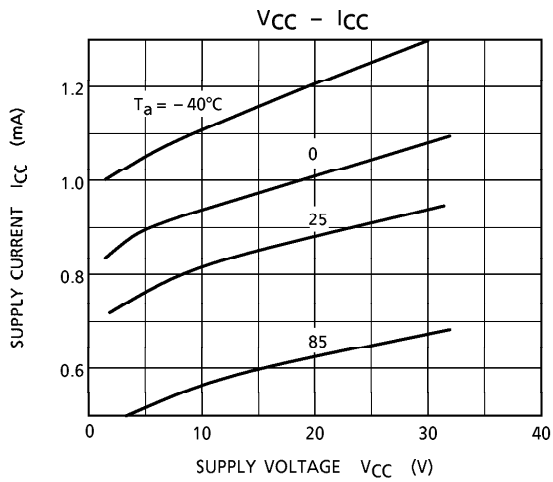

OUTLINE DRAWING  
DIP8-P-300-2.54A

Unit : mm

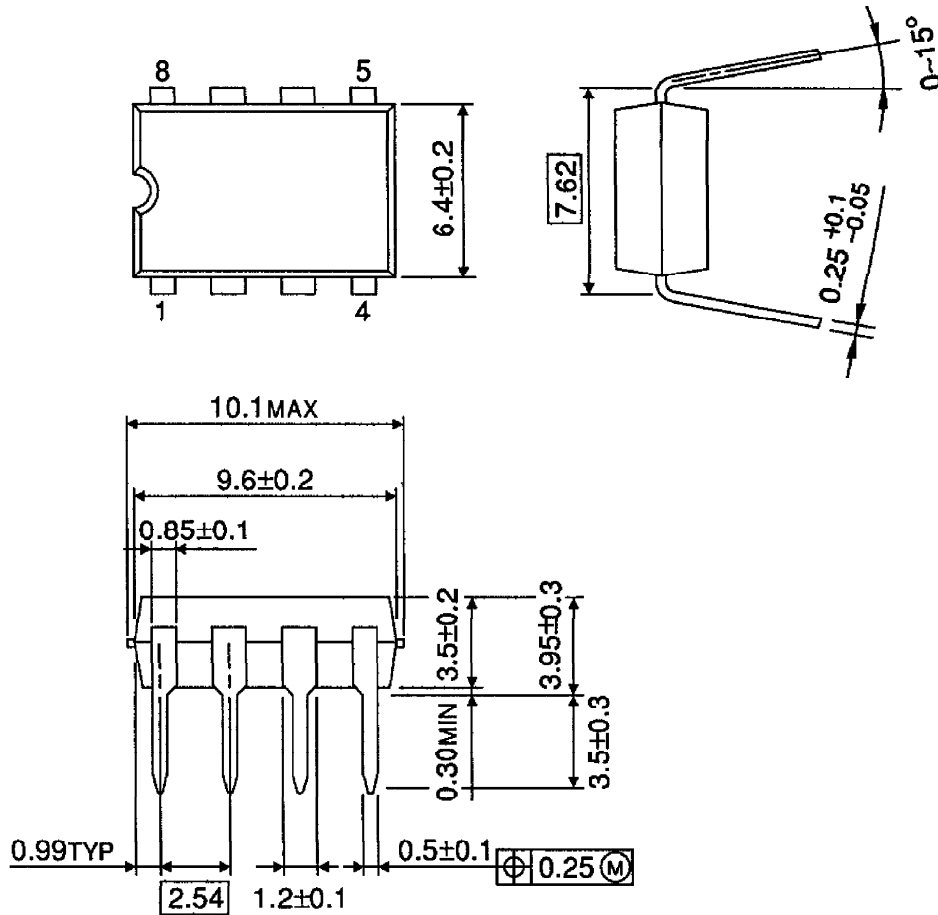

Weight : 0.5g (Typ.)

**OUTLINE DRAWING**  
DIP8-P-300-2.54C

Unit : mm

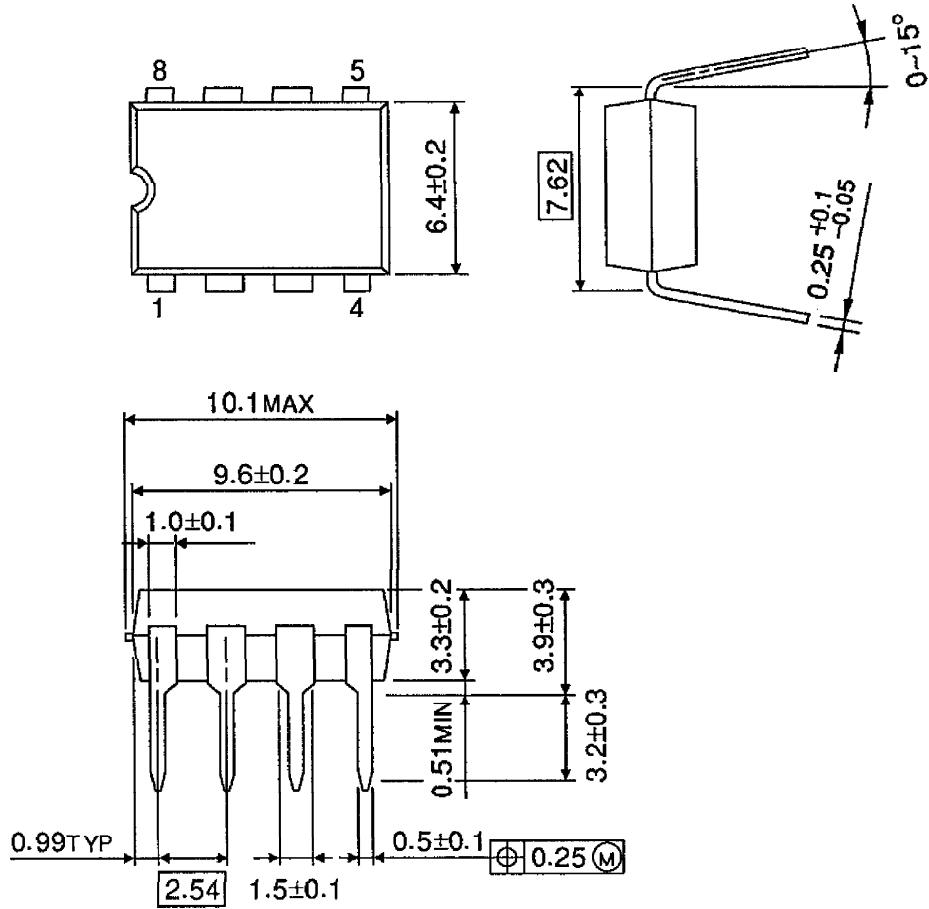

Weight : 0.6g (Typ.)



OUTLINE DRAWING  
SIP9-P-2.54A

Unit : mm

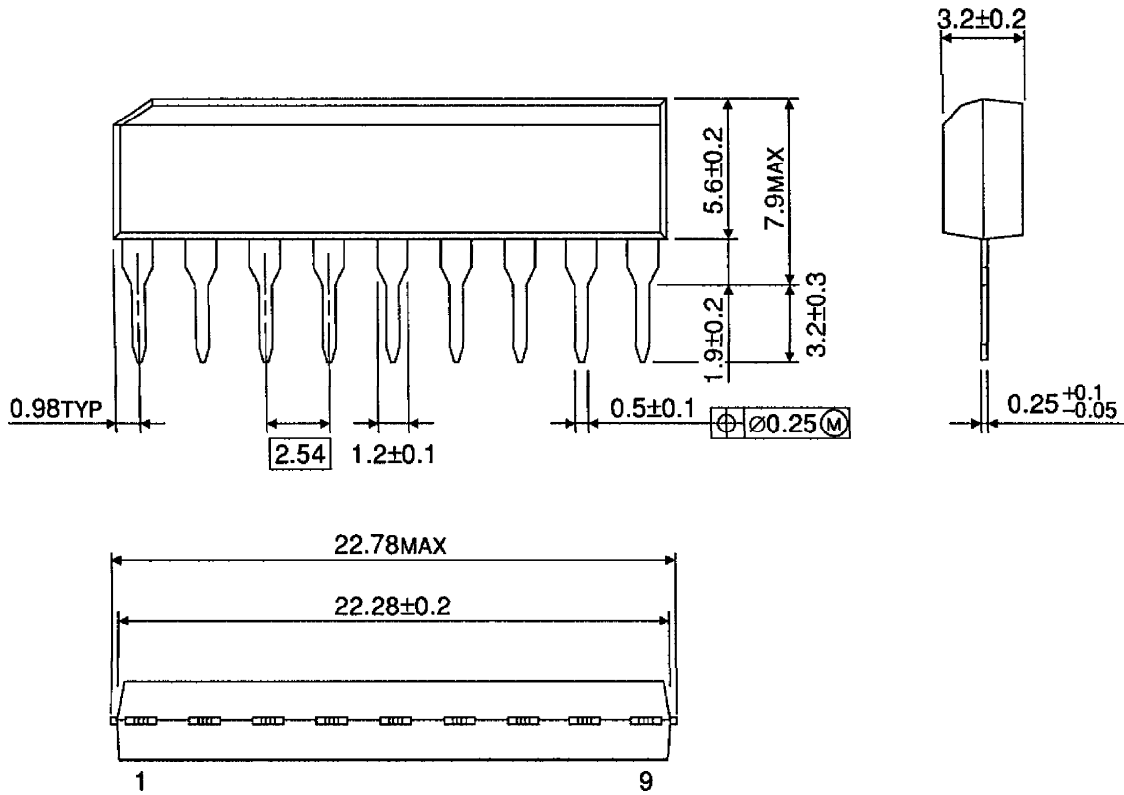

Weight : 0.9g (Typ.)

OUTLINE DRAWING  
SOP8-P-225-1.27

Unit : mm

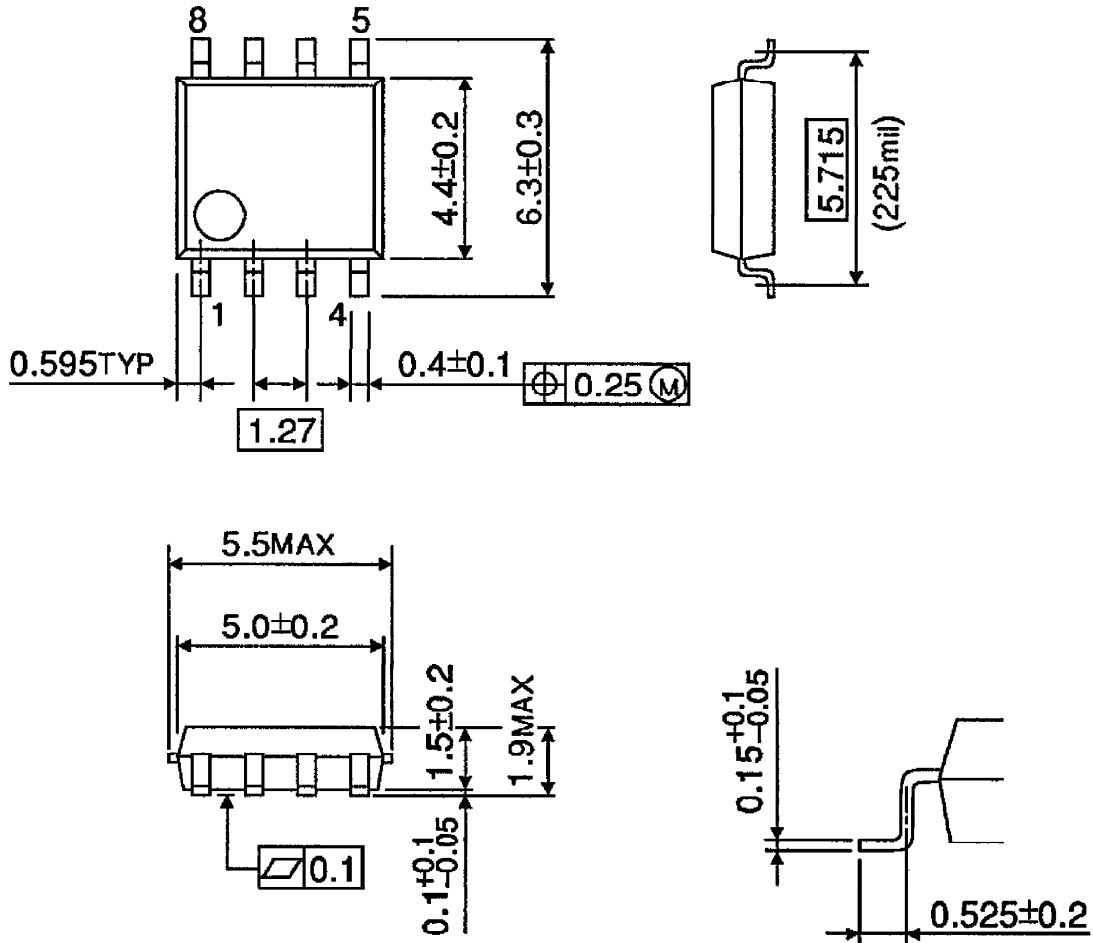

Weight : 0.1g (Typ.)

**OUTLINE DRAWING**  
SOP8-P-225-1.27B

Unit : mm

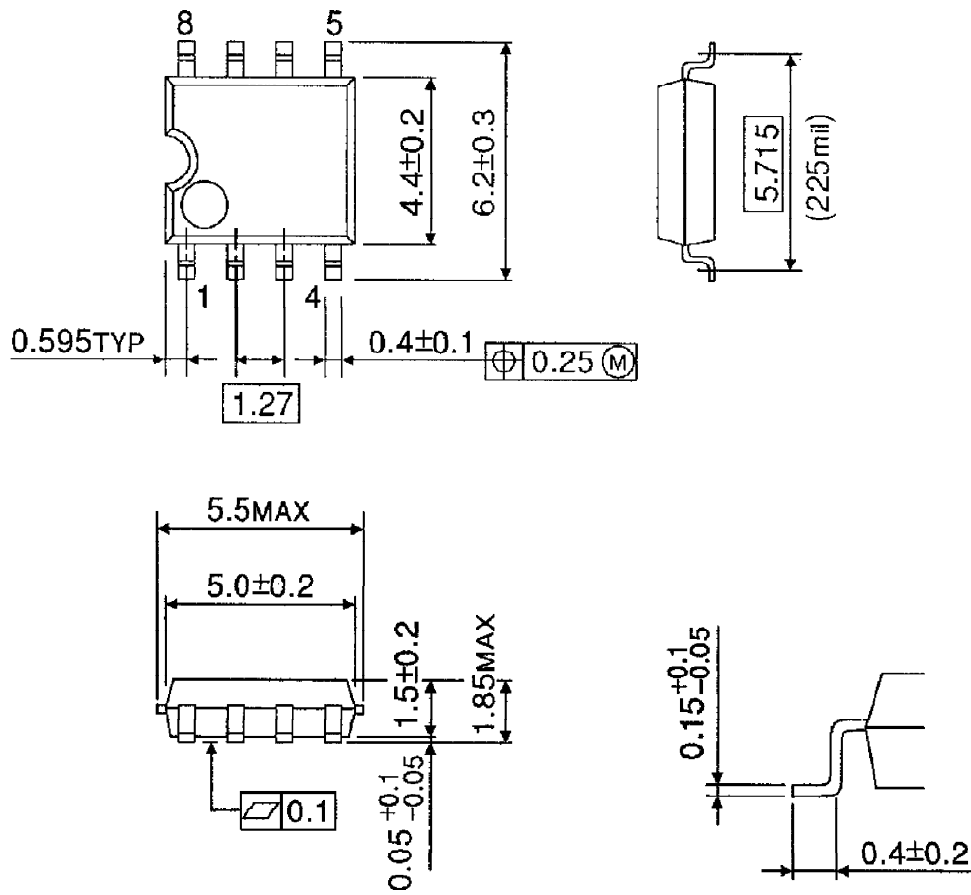

Weight : 0.1g (Typ.)