

TOSHIBA BIPOLAR LINEAR INTEGRATED CIRCUIT SILICON MONOLITHIC

TA75061P

SINGLE OPERATIONAL AMPLIFIER

The TA75061P is a J-FET input low-power operational amplifier with low input bias and offset current and fast slew rate. The TA75061P is pin compatible with the TA7504P and 741. The TA75061P is an excellent choice for active filters, integrators, buffers and sample-and-hold circuits.

FEATURES

- Low Supply Current : 250 μ A Max.
- Low Input Bias Current : 400pA Max.
- Low Input Offset Current : 200pA Max.
- High Slew Rate : 3.5V / μ s
- Wide Supply Voltage Range : $\pm 2 \sim \pm 18$ V
- Internal Frequency Compensation
- Output Short Circuit Protection
- Offset Null Capability

PIN CONNECTION (TOP VIEW)

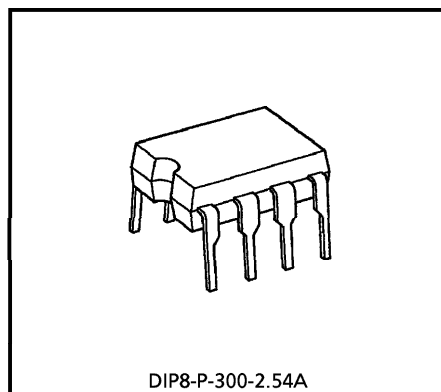
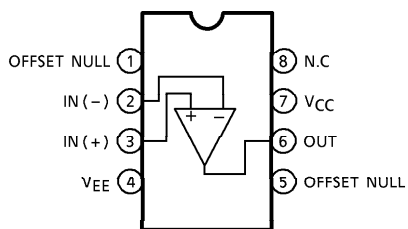

Weight : 0.5g (Typ.)

961001EBA1

- TOSHIBA is continually working to improve the quality and the reliability of its products. Nevertheless, semiconductor devices in general can malfunction or fail due to their inherent electrical sensitivity and vulnerability to physical stress. It is the responsibility of the buyer, when utilizing TOSHIBA products, to observe standards of safety, and to avoid situations in which a malfunction or failure of a TOSHIBA product could cause loss of human life, bodily injury or damage to property. In developing your designs, please ensure that TOSHIBA products are used within specified operating ranges as set forth in the most recent products specifications. Also, please keep in mind the precautions and conditions set forth in the TOSHIBA Semiconductor Reliability Handbook.
- The products described in this document are subject to foreign exchange and foreign trade control laws.
- The information contained herein is presented only as a guide for the applications of our products. No responsibility is assumed by TOSHIBA CORPORATION for any infringements of intellectual property or other rights of the third parties which may result from its use. No license is granted by implication or otherwise under any intellectual property or other rights of TOSHIBA CORPORATION or others.
- The information contained herein is subject to change without notice.

EQUIVALENT CIRCUIT

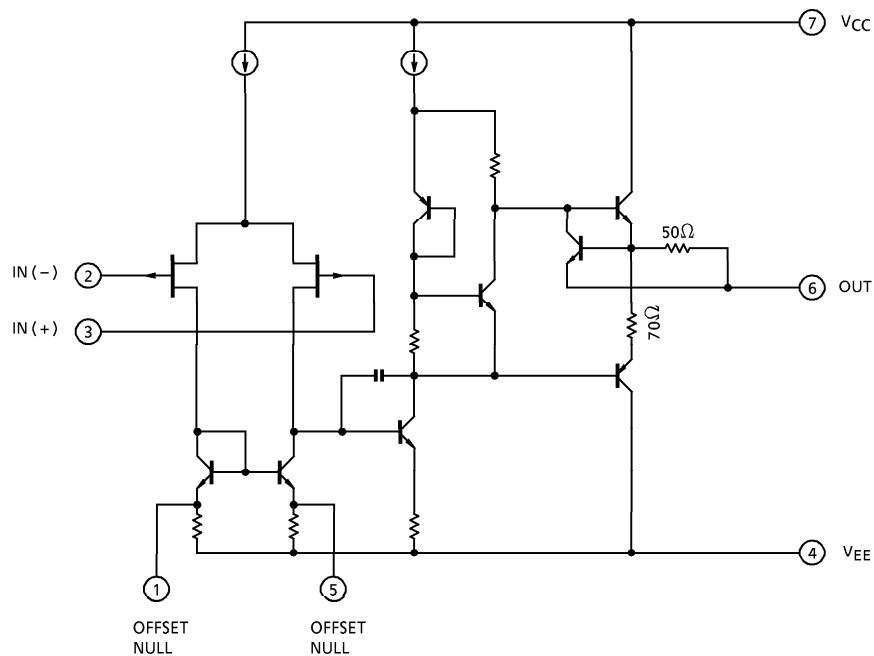

MAXIMUM RATINGS (Ta = 25°C)

CHARACTERISTIC	SYMBOL	RATING	UNIT
Supply Voltage	V _{CC}	18	V
	V _{EE}	- 18	V
Differential Input Voltage	DV _{IN}	± 30	V
Input Voltage	V _{IN}	± 15	V
Power Dissipation	P _D	500	mW
Operating Temperature	T _{opr}	- 40~85	°C
Storage Temperature	T _{stg}	- 55~125	°C

ELECTRICAL CHARACTERISTICS ($V_{CC} = 15V$, $V_{EE} = -15V$, $T_a = 25^\circ C$)

CHARACTERISTIC	SYMBOL	TEST CIR-CUIT	TEST CONDITION	MIN.	TYP.	MAX.	UNIT
Input Offset Voltage	V_{IO}	—	$R_g \leq 10k\Omega$	—	3	15	mV
TC of Input Offset Voltage	TCV_{IO}	—	—	—	10	—	$\mu V / ^\circ C$
Input Offset Current	I_{IO}	—	—	—	5	200	pA
Input Bias Current	I_I	—	—	—	30	400	pA
Common Mode Input Voltage	CMV_{IN}	—	—	± 11.5	± 12	—	V
Maximum Output Voltage	V_{OM}	—	$R_L = 10k\Omega$	20	27	—	V_{p-p}
Voltage Gain (Open Loop)	G_V	—	$V_{OUT} = \pm 10V$, $R_L = 10k\Omega$	3	6	—	V / mV
Unity Gain Cross Frequency	f_T	—	Open Loop, $R_L = 10k\Omega$	—	1	—	MHz
Input Resistance	R_{IN}	—	—	—	12^{12}	—	Ω
Common Mode Input Signal Rejection Ratio	$CMRR$	—	$R_g \leq 10k\Omega$	70	76	—	dB
Supply Voltage Rejection Ratio	$SVRR$	—	$R_g \leq 10k\Omega$	70	76	—	dB
Supply Current	I_{CC} , I_{EE}	—	Non load	—	200	250	μA

OPERATING CHARACTERISTICS ($V_{CC} = 15V$, $V_{EE} = -15V$, $T_a = 25^\circ C$)

CHARACTERISTIC	SYMBOL	TEST CIR-CUIT	TEST CONDITION	MIN.	TYP.	MAX.	UNIT
Slew Rate	SR	—	$V_{IN} = 10V_{p-p}$, $R_L = 10k\Omega$, $C_L = 100pF$	—	3.5	—	V / μs
Equivalent Input Noise Voltage	V_n	—	$R_S = 100\Omega$, $f = 1kHz$	—	42	—	nV \sqrt{Hz}

CHARACTERISTICS

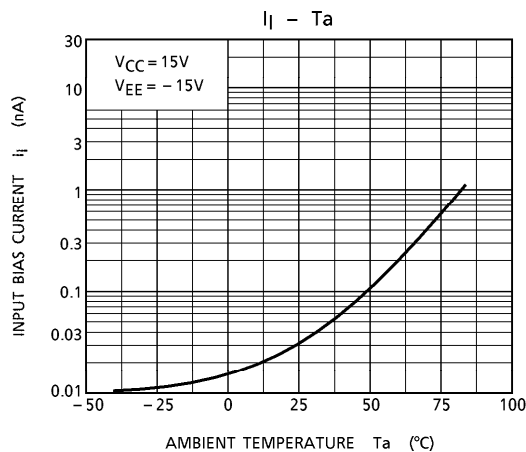
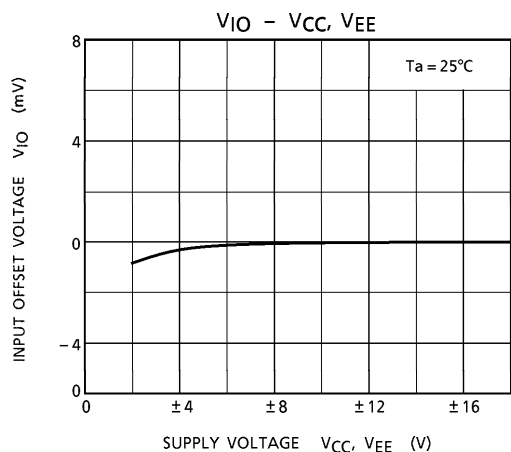
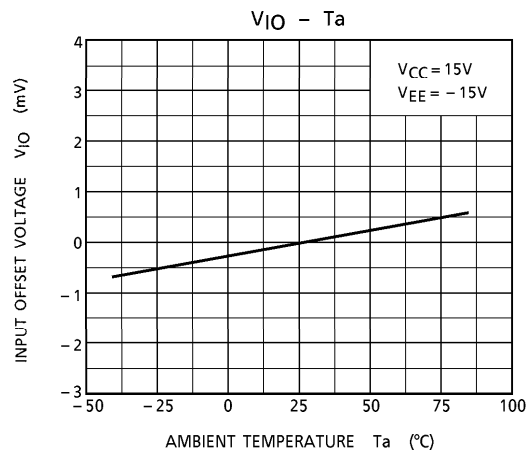
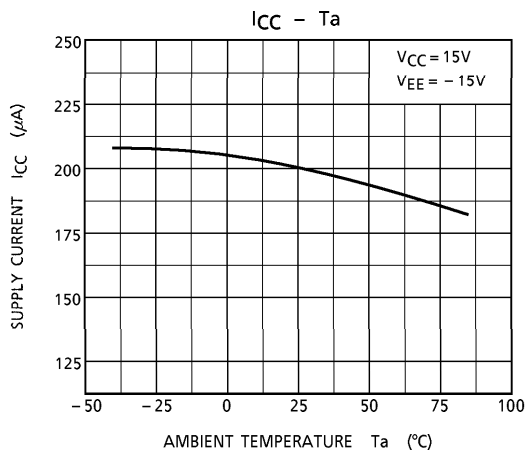
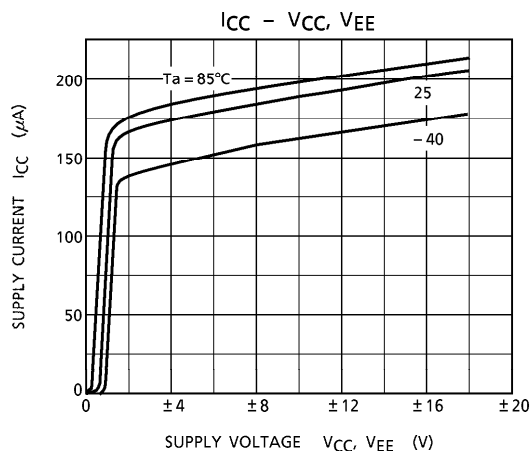
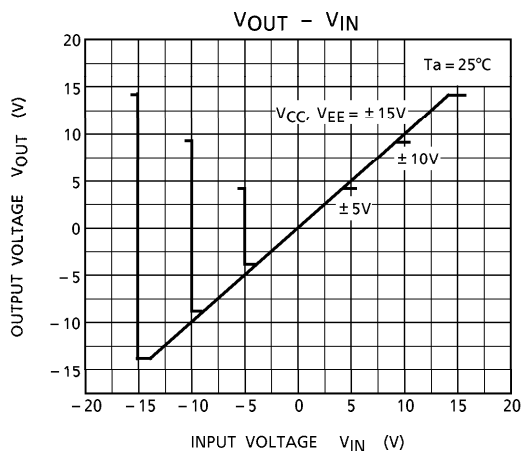

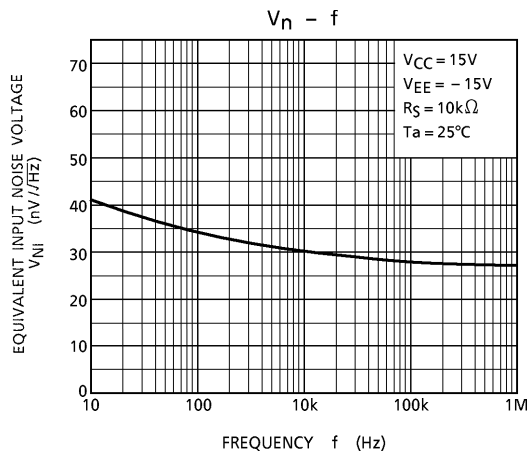
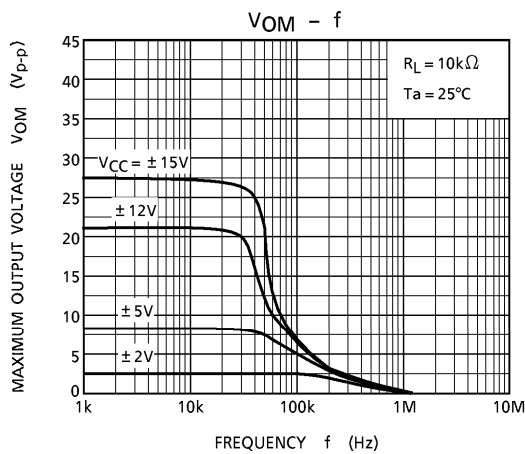
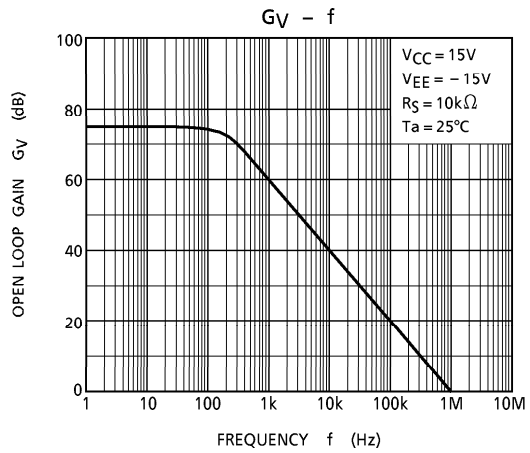
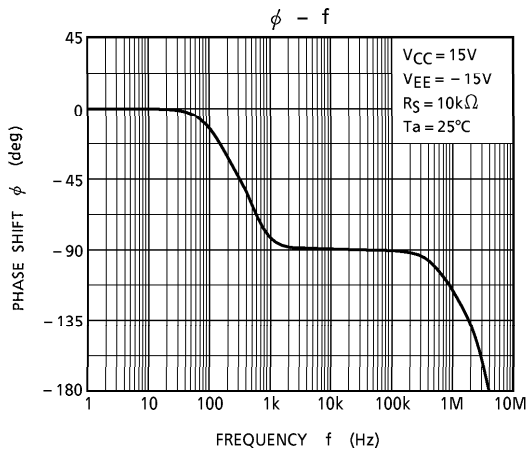
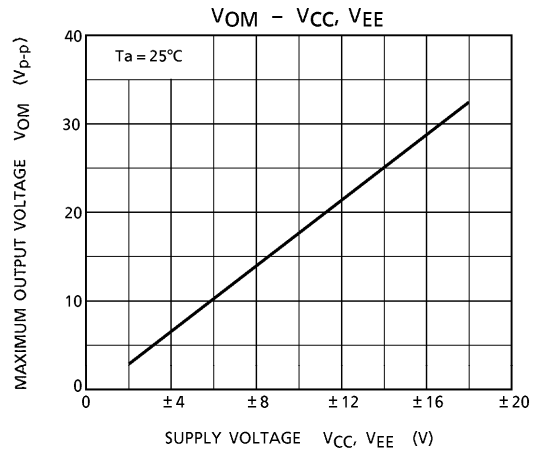
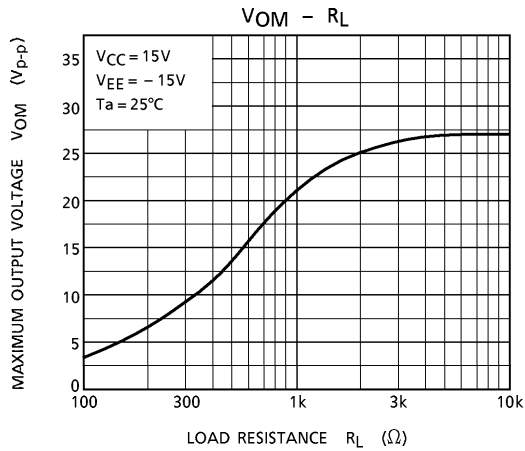

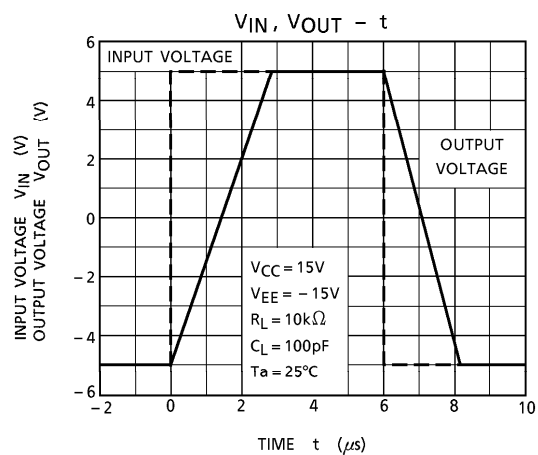

OUTLINE DRAWING
DIP8-P-300-2.54A

Unit : mm

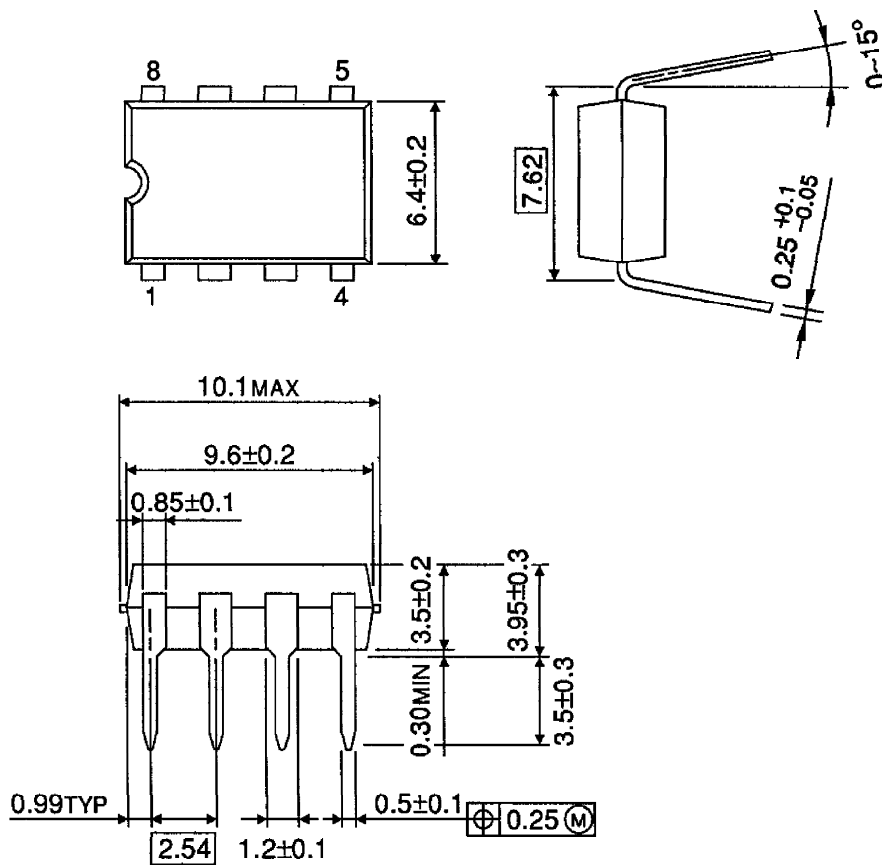

Weight : 0.5g (Typ.)