

4-Channel Current Source White LED Driver

General Description

The LP3164 is a low-dropout bias supply for white LEDs is a high-performance alternative to the simple ballast resistors used in conventional white LED designs. It supports 4 white LEDs with regulated constant current for uniform intensity. The LP3164 maintains low dropout current regulators. The LP3164 requires a 50mV dropout at a 20mA load on each output to match the LED brightness. The brightness of LEDs can be tuned through a pulse width modulated signal at the PWM pin.

The LP3164 is available in a QFN-16 package.

Features

- ✧ 2.7V to 6V Input Voltage
- ✧ 20mA maxim sink current
- ✧ PWM tuned LED brightness through PWM pin(2KHz)
- ✧ Soft Start Function
- ✧ Built-in Thermal Protection
- ✧ $I_Q < 1\mu A$ in Shutdown
- ✧ QFN-16 Package
- ✧ RoHS Compliant and 100% Lead (Pb)-Free

Typical Application Circuit

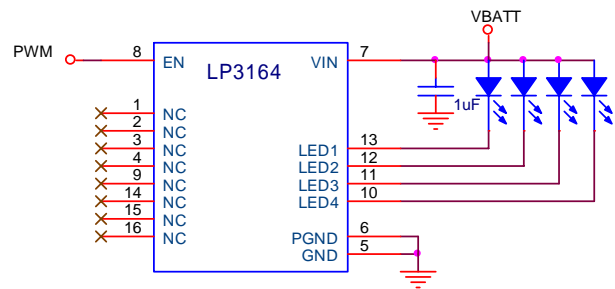

Order Information

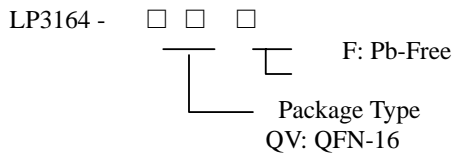

Marking Information

Please see website.

Applications

- ✧ LCD Panel
- ✧ Cellular and Smart mobile phone
- ✧ PDA/DSC
- ✧ PMP

Functional Pin Description

Part No.	Package Type	Pin Configurations
LP3164	QFN-16	
PIN	NAME	DESCRIPTION
QFN-16		
1,2,3,4,9,14,15,16	NC	No Internal Connection.
5/6	AGND/PGND	Ground.
7	VIN	Power Supply.
8	EN/PWM	Chip Enable(active High).and connects to a GPIO of MCU,the GPIO supply a PWM signal dimming method to control the brightness(0-20mA) of white LEDs and the PWM frequency from 200Hz to 10KHz,the duty from 0% to 100%.the typical frequency is 2KHz.
10	LED4	LED4 cathode terminal.
11	LED3	LED3 cathode terminal.
12	LED2	LED2 cathode terminal.
13	LED1	LED1 cathode terminal

Function Block Diagram

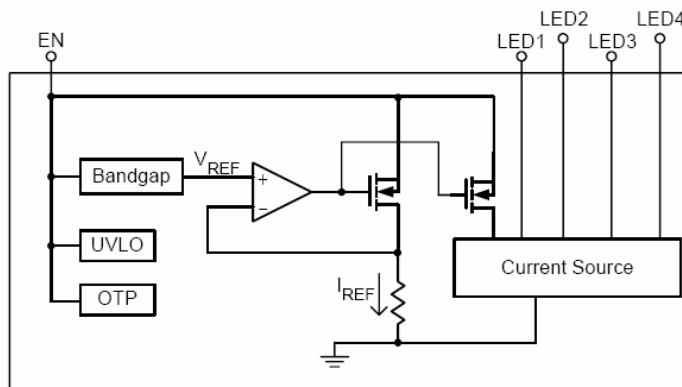

Absolute Maximum Ratings

- ✧ Input Voltage to GND (V_{INA}, V_{INB}) ----- 6V
- ✧ EN/LED to GND Voltage ($V_{en/LED}$) ----- 0.3V to $V_{in}+0.3V$
- ✧ Maximum DC Output Current(I_{out}) ----- 150mA
- ✧ Operating Junction Temperature Range (T_j) -----40°C to 150°C
- ✧ Maximum Soldering Temperature (at leads, 10sec) -----300°C

Thermal Information

- ✧ Maximum Power Dissipation (P_D) QFN-16 ----- 1.5W
- ✧ Thermal Resistance (J_A) -----50°C/W

Electrical Characteristics

(Over recommended operating conditions unless specified otherwise) $V_{INA}=3.6V, EN=High, T_A=25^\circ C$)

Symbol	Parameter	Conditions	LP3164			Unit
			Min.	Typ.	Max.	
V_{IN}	Input Voltage		3		5.5	V
V_{OUT}	Output Voltage Range		0.6		V_{INB}	V
I_Q	Quiescent Current	No Load, 1X mode		100	250	uA
I_{SHDN}	Shutdown Current	ENB = GND		0.1	1	μA
$I_{LED-ERR}$	LED Current Accuracy	3mA < I_{LED} < 30mA	19	20	21	mA
$I_{LED-LED-ERR}$	LED Channel Matching	Any two channel mismatch	-3		3	%
$V_{EN(L)}$	Enable Threshold Low				0.5	V
$V_{EN(H)}$	Enable Threshold High		2			V

Typical Operating Characteristics

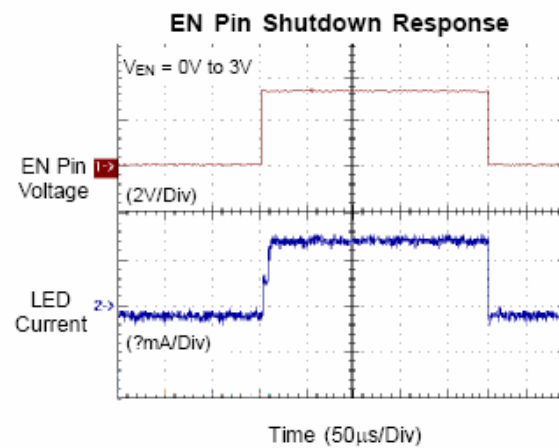
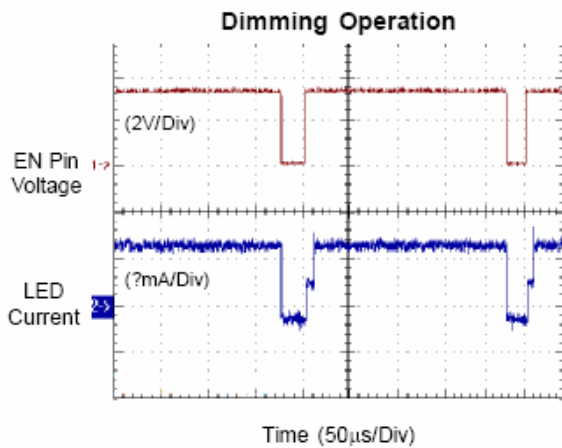
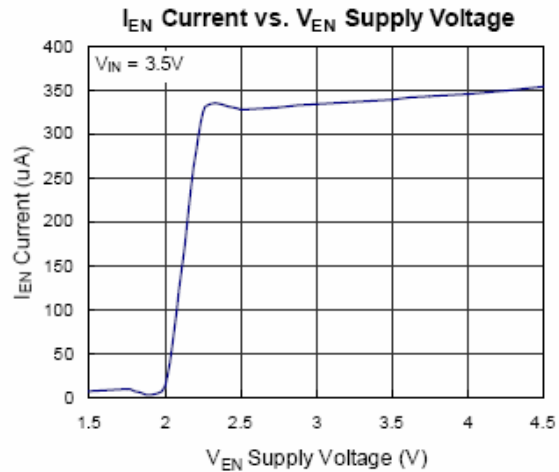
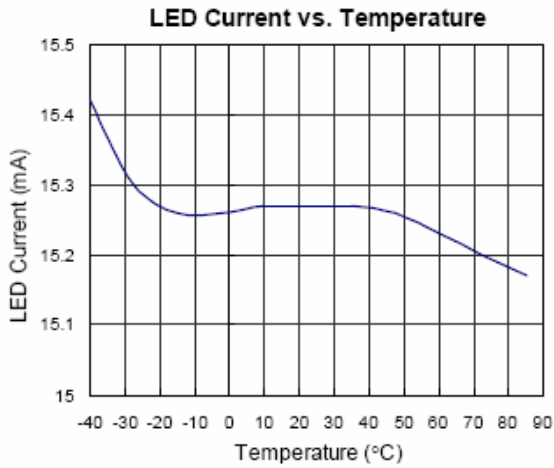
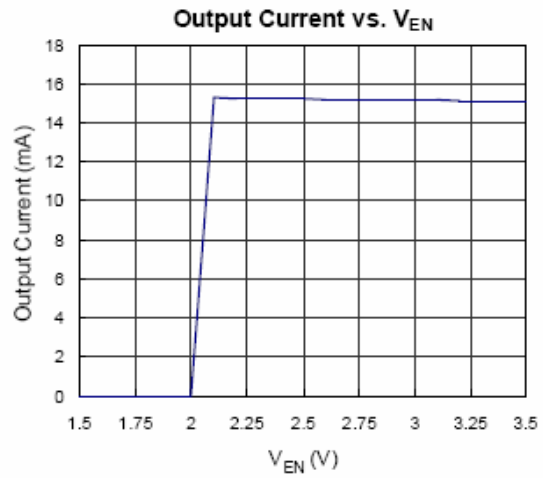
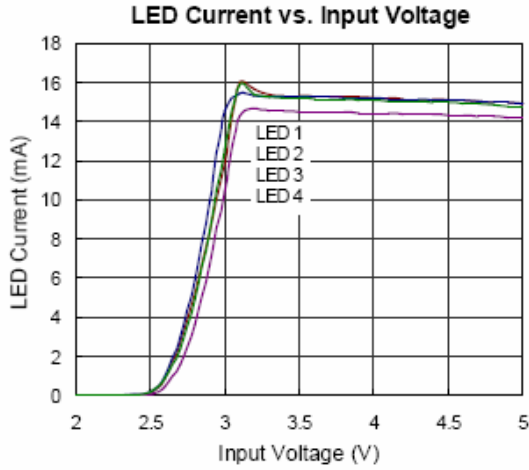

Packaging Information

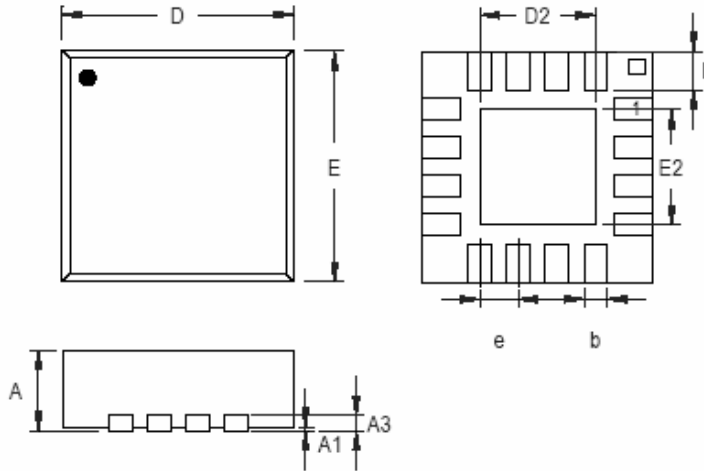

Symbol	Dimensions In Millimeters		Dimensions In Inches	
	Min	Max	Min	Max
A	0.800	1.000	0.031	0.039
A1	0.000	0.050	0.000	0.002
A3	0.200 Ref.		0.008 Ref.	
b	0.180	0.300	0.007	0.012
D	3.000		0.118	
D2	1.250	1.900	0.049	0.075
E	3.000		0.118	
E2	1.250	1.900	0.049	0.075
e	0.500		0.020	
L	0.300	0.500	0.012	0.020