

LMV7235/LMV7239

45 nsec, Ultra Low Power, Low Voltage, Rail-to-Rail Input Comparator with Open-Drain/ Push-Pull Output

General Description

The LMV7235/LMV7239 are ultra low power, low voltage, 45 nsec comparators. They are guaranteed to operate over the full supply voltage range of 2.7V to 5V. These devices achieve a 45 nsec propagation delay while consuming only 65µA of supply current at 5V.

The LMV7235/LMV7239 have a greater than rail-to-rail common mode voltage range. The input common mode voltage range extends 200mV below ground and 200mV above supply, allowing both ground and supply sensing.

The LMV7235 features an open drain output. By connecting an external resistor, the output of the comparator can be used as a level shifter.

The LMV7239 features a push-pull output stage. This feature allows operation without the need of an external pull-up resistor.

The LMV7235/LMV7239 are available in the 5-Pin SC70 and 5-Pin SOT23 packages, which are ideal for systems where small size and low power is critical.

Features

($V_S = 5V$, $T_A = 25^\circ C$, Typical values unless otherwise specified)

- Propagation delay 45 nsec
- Low supply current 65µA
- Rail-to-Rail input
- Open drain and push-pull output
- Ideal for 2.7V and 5V single supply applications
- Available in space saving packages
 - 5-pin SOT23
 - 5-pin SC70

Applications

- Portable and battery powered systems
- Scanners
- Set top boxes
- High speed differential line receiver
- Window comparators
- Zero-crossing detectors
- High speed sampling circuits

Typical Application

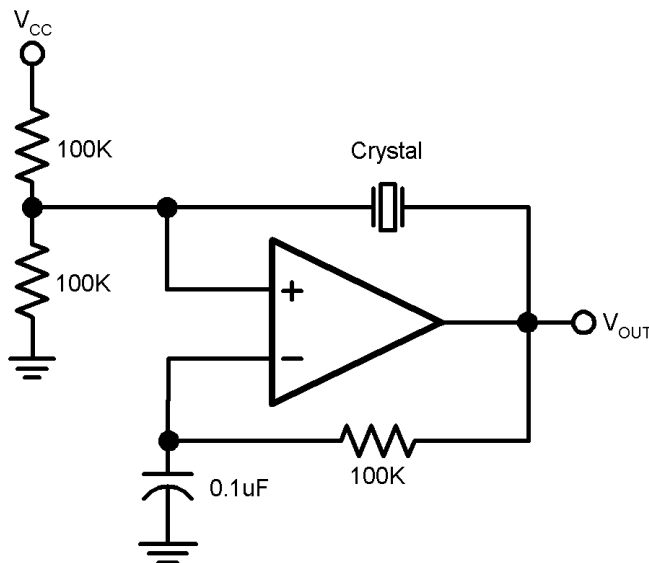

Crystal Oscillator

10135902

Connection Diagram

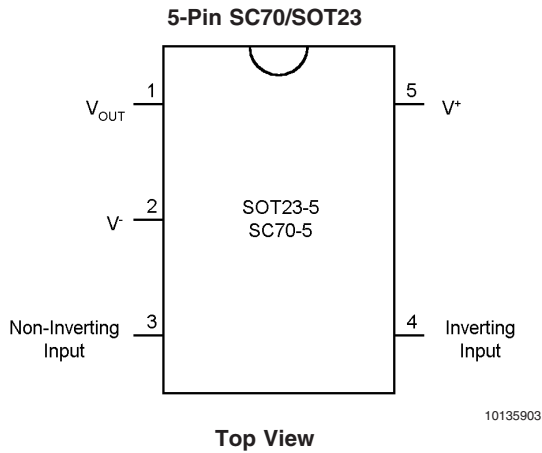

Ordering Information

| Package | Part Number | Marking | Supplied as | NSC Drawing |
|-------------|-------------|---------|------------------------|-------------|
| 5-pin SC70 | LMV7235M7 | C21 | 1k Units Tape and Reel | MAA05A |
| | LMV7235M7X | | 3k Units Tape and Reel | |
| | LMV7239M7 | C20 | 1k Units Tape and Reel | |
| | LMV7239M7X | | 3k Units Tape and Reel | |
| 5-pin SOT23 | LMV7235M5 | C21A | 1k Units Tape and Reel | MF05A |
| | LMV7235M5X | | 3k Units Tape and Reel | |
| | LMV7239M5 | C20A | 1k Units Tape and Reel | |
| | LMV7239M5X | | 3k Units Tape and Reel | |

Simplified Schematic

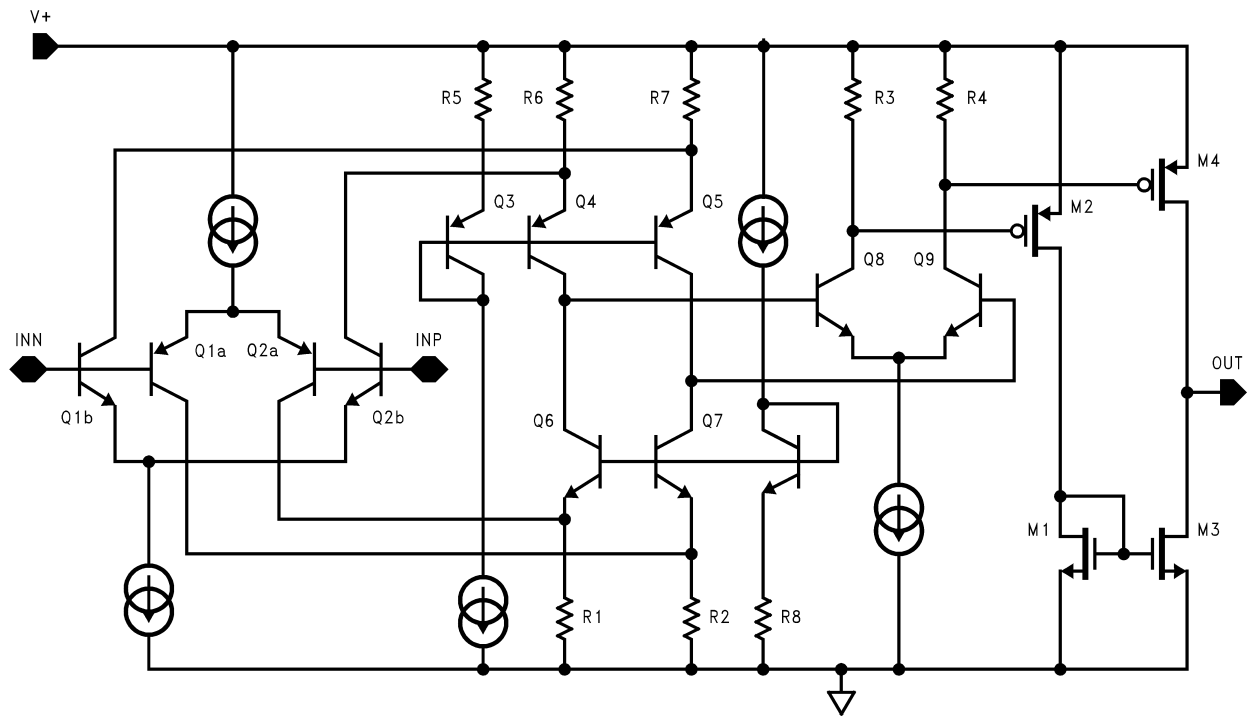

Absolute Maximum Ratings (Note 1)

If Military/Aerospace specified devices are required, please contact the National Semiconductor Sales Office/Distributors for availability and specifications.

| | |
|---------------------------------|------------------|
| ESD Tolerance (Note 2) | |
| Human Model Body | 1000V |
| Machine Body | 100V |
| Differential Input Voltage | ± Supply Voltage |
| Output Short Circuit Duration | (Note 3) |
| Supply Voltage ($V^+ - V^-$) | 5.5V |
| Soldering Information | |
| Infrared or Convection (20 sec) | 235°C |

| | |
|-------------------------------|----------------------------------|
| Wave Soldering (10 sec) | 260°C (lead temp) |
| Voltage at Input/Output Pins | (V^+) +0.3V, (V^-) -0.3V |
| Current at Input Pin (Note 9) | ±10mA |

Operating Ratings

| | |
|---------------------------------|-----------------|
| Supply Voltages ($V^+ - V^-$) | 2.7V to 5V |
| Temperature Range (Note 4) | -40°C to +85°C |
| Storage Temperature Range | -65°C to +150°C |
| Package Thermal Resistance | |
| 5-Pin SC70 | 478°C/W |
| 5-Pin SOT23 | 265°C/W |

2.7V Electrical Characteristics

Unless otherwise specified, all limits guaranteed for $T_A = 25^\circ\text{C}$, $V_{CM} = V^+/2$, $V^+ = 2.7\text{V}$, $V^- = 0\text{V}$. **Boldface** limits apply at the temperature extremes.

| Symbol | Parameter | Conditions | Min (Note 6) | Typ (Note 5) | Max (Note 6) | Units | |
|------------|--|--|--|-----------------|--|---------------|----|
| V_{OS} | Input Offset Voltage | | | 0.8 | 6 8 | mV | |
| I_B | Input Bias Current | | | 30 | 400 600 | nA | |
| I_{OS} | Input Offset Current | | | 5 | 200 400 | nA | |
| CMRR | Common Mode Rejection Ratio | $0\text{V} < V_{CM} < 2.7\text{V}$ (Note 7) | 52 | 62 | | dB | |
| PSRR | Power Supply Rejection Ratio | $V^+ = 2.7\text{V}$ to 5V | 65 | 85 | | dB | |
| V_{CM} | Input Common-Mode Voltage Range | CMRR > 50dB | $V^- - 0.1$ V^- | -0.2 to 2.9 | $V^+ + 0.1$ V^+ | V | |
| V_O | Output Swing High (LMV7239 only) | $I_L = 4\text{mA}$, $V_{ID} = 500\text{mV}$ | $V^+ - 0.35$ | $V^+ - 0.26$ | | V | |
| | | $I_L = 0.4\text{mA}$, $V_{ID} = 500\text{mV}$ | | $V^+ - 0.02$ | | V | |
| | Output Swing Low (LMV7239/LMV7235) | $I_L = -4\text{mA}$, $V_{ID} = -500\text{mV}$ | | 230 | 350 450 | | mV |
| | | $I_L = -0.4\text{mA}$, $V_{ID} = -500\text{mV}$ | | | 15 | | mV |
| I_{SC} | Output Short Circuit Current | Sourcing, $V_O = 0\text{V}$ (LMV7239 only) (Note 3) | | 15 | | mA | |
| | | Sinking, $V_O = 2.7\text{V}$ (LMV7235 $R_L = 10\text{k}$) (Note 3) | | 20 | | mA | |
| I_S | Supply Current | No load | | 52 | 85 100 | μA | |
| t_{PD} | Propagation Delay | Overdrive = 20mV (Note 10) | | 68 | | ns | |
| | | Overdrive = 50mV (Note 10) | | 63 | | ns | |
| | | Overdrive = 100mV (Note 10) | | 50 | | ns | |
| t_{SKEW} | Propagation Delay Skew (LMV7239 only) | (Note 8) | | 5 | | ns | |

2.7V Electrical Characteristics (Continued)

Unless otherwise specified, all limits guaranteed for $T_A = 25^\circ\text{C}$, $V_{CM} = V^+/2$, $V^+ = 2.7\text{V}$, $V^- = 0\text{V}$. **Boldface** limits apply at the temperature extremes.

| Symbol | Parameter | Conditions | Min (Note 6) | Typ (Note 5) | Max (Note 6) | Units |
|---------------|--|------------------------------------|-----------------|-----------------|-----------------|-------|
| t_r | Output Rise Time | LMV7239 10% to 90% | | 1.7 | | ns |
| | | LMV7235 10% to 90% (Note 10) | | 112 | | ns |
| t_f | Output Fall Time | 90% to 10% | | 1.7 | | ns |
| $I_{LEAKAGE}$ | Output Leakage Current (LMV7235 only) | | | 3 | | nA |

5V Electrical Characteristics

Unless otherwise specified, all limits guaranteed for $T_A = 25^\circ\text{C}$, $V_{CM} = V^+/2$, $V^+ = 5\text{V}$, $V^- = 0\text{V}$. **Boldface** limits apply at the temperature extremes.

| Symbol | Parameter | Conditions | Min (Note 6) | Typ (Note 5) | Limits (Note 6) | Units | |
|------------|--|---|--|------------------|--|---------------|----|
| V_{OS} | Input Offset Voltage | | | 1 | 6 8 | mV | |
| I_B | Input Bias Current | | | 30 | 400 600 | nA | |
| I_{OS} | Input Offset Current | | | 5 | 200 400 | nA | |
| CMRR | Common Mode Rejection Ratio | $0\text{V} < V_{CM} < 5\text{V}$ | 52 | 67 | | dB | |
| PSRR | Power Supply Rejection Ratio | $V^+ = 2.7\text{V}$ to 5V | 65 | 85 | | dB | |
| V_{CM} | Input Common-Mode Voltage Range | CMRR > 50dB | $V^- - 0.1$ V^- | -0.2 to 5.2 | $V^+ + 0.1$ V^+ | V | |
| V_O | Output Swing High (LMV7239 only) | $I_L = 4\text{mA}$, $V_{ID} = 500\text{mV}$ | $V^+ - 0.25$ | $V^+ - 0.15$ | | V | |
| | | $I_L = 0.4\text{mA}$, $V_{ID} = 500\text{mV}$ | | $V^+ - 0.01$ | | V | |
| | Output Swing Low (LMV7239/LMV7235) | $I_L = -4\text{mA}$, $V_{ID} = -500\text{mV}$ | | 230 | 350 450 | | mV |
| | | $I_L = -0.4\text{mA}$, $V_{ID} = -500\text{mV}$ | | 10 | | | mV |
| I_{SC} | Output Short Circuit Current | Sourcing, $V_O = 0\text{V}$ (LMV7239 only) (Note 3) | 25 15 | 55 | | mA | |
| | | Sinking, $V_O = 5\text{V}$ (LMV7235 $R_L = 10\text{k}$) (Note 3) | 30 20 | 60 | | mA | |
| I_S | Supply Current | No load | | 65 | 95 110 | μA | |
| t_{PD} | Propagation Delay | Overdrive = 20mV (Note 10) | | 62 | | ns | |
| | | Overdrive = 50mV (Note 10) | | 57 | | ns | |
| | | Overdrive = 100mV (Note 10) | | 45 | | ns | |
| t_{SKEW} | Propagation Delay Skew (LMV7239 only) | (Note 8) | | 5 | | ns | |

5V Electrical Characteristics (Continued)

Unless otherwise specified, all limits guaranteed for $T_A = 25^\circ\text{C}$, $V_{CM} = V^+/2$, $V^+ = 5\text{V}$, $V^- = 0\text{V}$. **Boldface** limits apply at the temperature extremes.

| Symbol | Parameter | Conditions | Min (Note 6) | Typ (Note 5) | Limits (Note 6) | Units |
|---------------|--|------------------------------------|-----------------|-----------------|--------------------|-------|
| t_r | Output Rise Time | LMV7239 10% to 90% | | 1.2 | | ns |
| | | LMV7235 10% to 90% (Note 10) | | 100 | | ns |
| t_f | Output Fall Time | 90% to 10% | | 1.2 | | ns |
| $I_{LEAKAGE}$ | Output Leakage Current (LMV7235 only) | | | 3 | | nA |

Note 1: Absolute Maximum Ratings indicate limits beyond which damage to the device may occur. Operating Ratings indicate conditions for which the device is intended to be functional, but specific performance is not guaranteed. For guaranteed specifications and the test conditions, see the Electrical characteristics.

Note 2: Human Body Model, applicable std. MIL-STD-883, Method 3015.7. Machine Model, applicable std. JESD22-A115-A (ESD MM std. of JEDEC) Field-Induced Charge-Device Model, applicable std. JESD22-C101-C (ESD FICDM std. of JEDEC).

Note 3: Applies to both single-supply and split-supply operation. Continuous short circuit operation at elevated ambient temperature can result in exceeding the maximum allowed junction temperature of 150°C . Output currents in excess of $\pm 30\text{mA}$ over long term may adversely affect reliability.

Note 4: The maximum power dissipation is a function of $T_{J(MAX)}$, θ_{JA} . The maximum allowable power dissipation at any ambient temperature is $PD = (T_{J(MAX)} - T_A) / \theta_{JA}$. All numbers apply for packages soldered directly onto a PC Board.

Note 5: Typical values represent the most likely parametric norm as determined at the time of characterization. Actual typical values may vary over time and will also depend on the application and configuration. The typical values are not tested and are not guaranteed on shipped production material.

Note 6: All limits are guaranteed by testing or statistical analysis.

Note 7: CMRR is not linear over the common mode range. Limits are guaranteed over the worst case from 0 to $V_{CC/2}$ or $V_{CC/2}$ to V_{CC} .

Note 8: Propagation Delay Skew is defined as the absolute value of the difference between t_{PDLH} and t_{PDHL} .

Note 9: Limiting input pin current is only necessary for input voltages that exceed absolute maximum input voltage ratings.

Note 10: A 10k pull-up resistor was used when measuring the LMV7235. The rise time of the LMV7235 is a function of the R-C time constant.

Typical Performance Characteristics (Unless otherwise specified, $V_S = 5V$, $C_L = 10pF$, $T_A = 25^\circ C$).

Supply Current vs. Supply Voltage

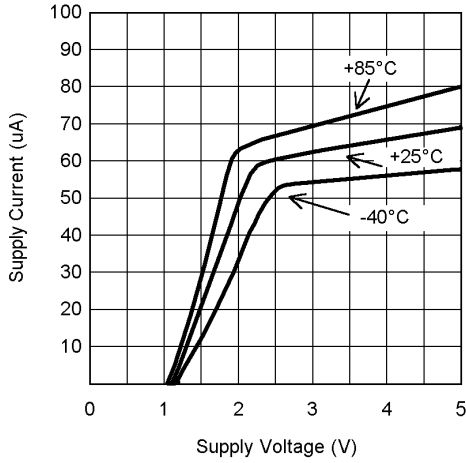

10135904

Sourcing Current vs. Output Voltage

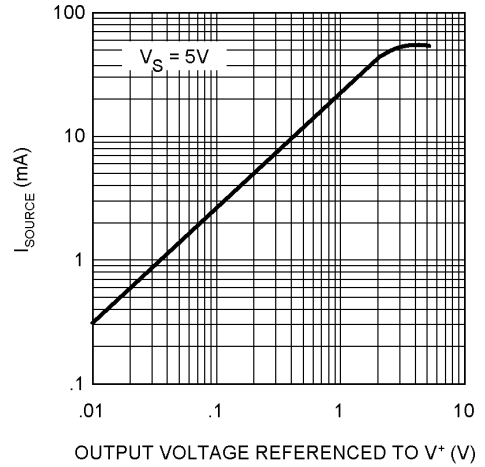

10135905

Sourcing Current vs. Output Voltage

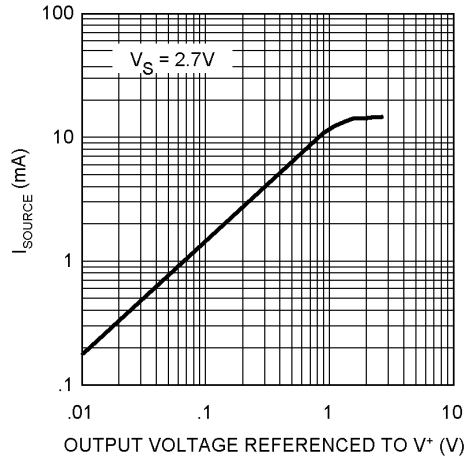

10135906

Sinking Current vs. Output Voltage

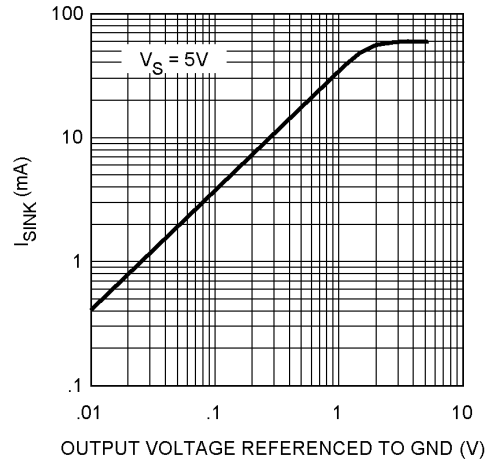

10135907

Sinking Current vs. Output Voltage

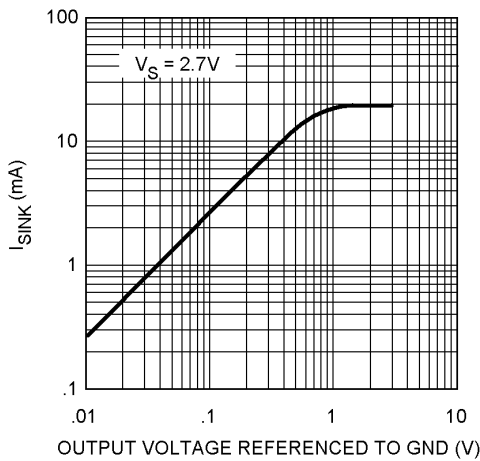

10135908

Input Bias Current vs. Input Voltage

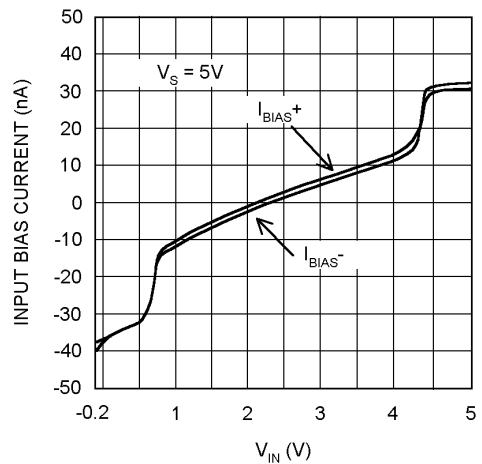

10135909

Typical Performance Characteristics (Unless otherwise specified, $V_S = 5V$, $C_L = 10pF$, $T_A = 25^\circ C$). (Continued)

Input Bias Current vs. Input Voltage

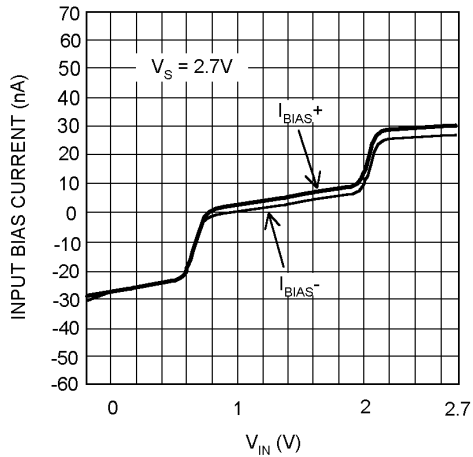

10135910

Propagation Delay vs. Temperature

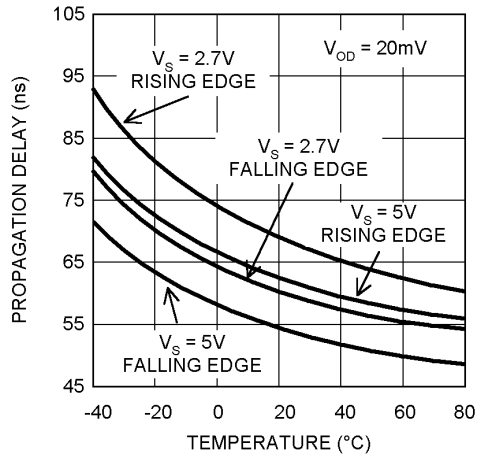

10135911

Propagation Delay vs. Capacitive Load

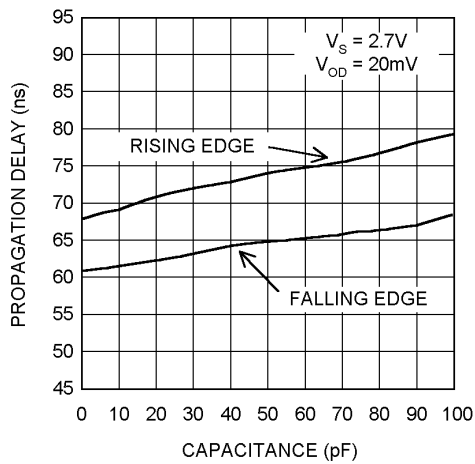

10135912

Propagation Delay vs. Capacitive Load

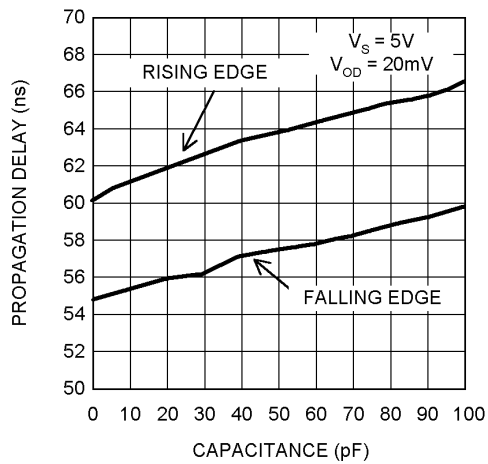

10135913

Propagation Delay vs. Input Overdrive

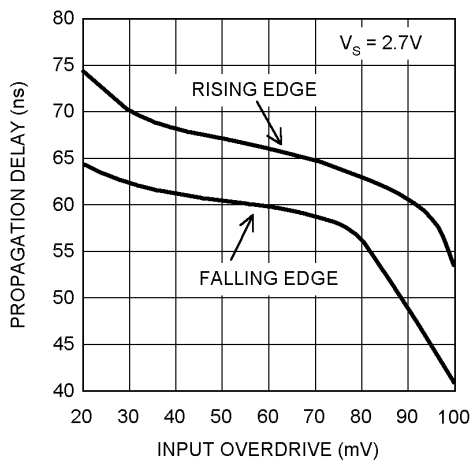

10135914

Propagation Delay vs. Input Overdrive

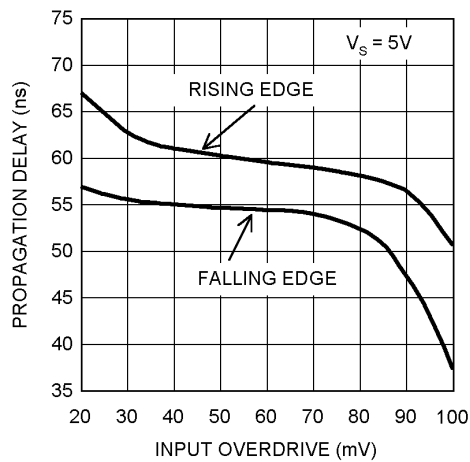

10135915

Typical Performance Characteristics (Unless otherwise specified, $V_S = 5V$, $C_L = 10pF$, $T_A = 25^\circ C$). (Continued)

Propagation Delay vs. Common Mode Voltage

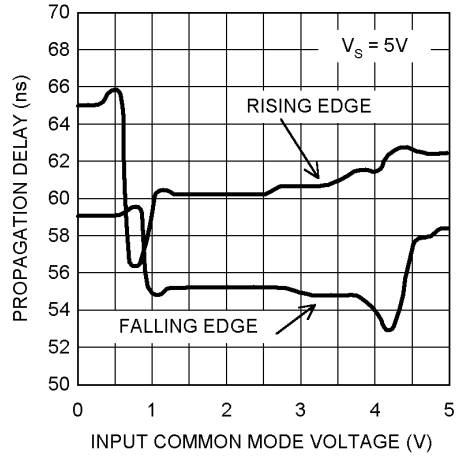

10135916

Propagation Delay vs. Common Mode Voltage

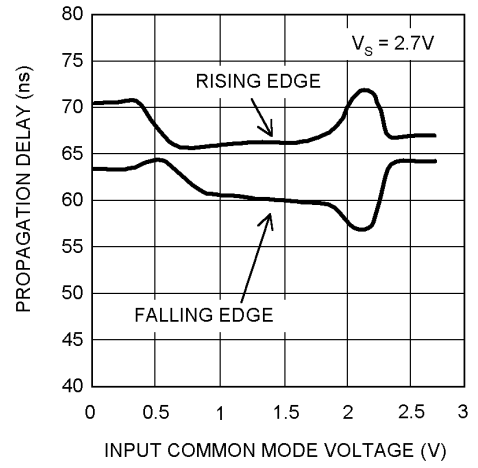

10135917

Application Information

The LMV7235/LMV7239 are single supply comparators with 45ns of propagation delay and only 65µA of supply current. The LMV7235/LMV7239 are rail-to-rail input and output. The typical input common mode voltage range of -0.2V below the ground to 0.2V above the supply. The LMV7235/LMV7239 use a complimentary PNP and NPN input stage in which the PNP stage senses common mode voltage near V⁻ and the NPN stage senses common mode voltage near V⁺. If either of the input signals falls below the negative common mode limit, the parasitic PN junction formed by the substrate and the base of the PNP will turn on resulting in an increase of input bias current.

If one of the input goes above the positive common mode limit, the output will still maintain the correct logic level as long as the other input stays within the common mode range. However, the propagation delay will increase. When both inputs are outside the common mode voltage range, current saturation occurs in the input stage, and the output becomes unpredictable.

The propagation delay does not increase significantly with large differential input voltages. However, large differential voltages greater than the supply voltage should be avoided to prevent damage to the input stage.

The LMV7239 has a push-pull output. When the output switches, there is a direct path between V_{CC} and ground, causing high output sinking or sourcing current during the transition. After the transition, the output current decreases and the supply current settles back to about 65µA at 5V, thus conserving power consumption.

The LMV7235 has an open drain that requires a pull-up resistor to a positive supply voltage for the output to switch properly. When the internal output transistor is off, the output voltage will be pulled up to the external positive voltage.

COMPARATOR WITH HYSTERESIS

The basic comparator configuration may oscillate or produce a noisy output if the applied differential input voltage is near the comparator's offset voltage. This usually happens when the input signal is moving very slowly across the comparator's switching threshold. This problem can be prevented by the addition of hysteresis or positive feedback.

INVERTING COMPARATOR WITH HYSTERESIS

The inverting comparator with hysteresis requires a three resistor network that is referenced to the supply voltage V_{CC} of the comparator, as shown in *Figure 1*. When V_{IN} at the inverting input is less than V_A, the voltage at the non-inverting node of the comparator (V_{IN} < V_A), the output voltage is high (for simplicity assume V_O switches as high as V_{CC}). The three network resistors can be represented as R1||R3 in series with R2. The lower input trip voltage V_{A1} is defined as

$$V_{A1} = V_{CC}R2 / ((R1||R3) + R2)$$

When V_{IN} is greater than V_A (V_{IN} > V_A), the output voltage is low, very close to ground. In this case the three network resistors can be presented as R2||R3 in series with R1. The upper trip voltage V_{A2} is defined as

$$V_{A2} = V_{CC} (R2||R3) / ((R1+ (R2||R3))$$

The total hysteresis provided by the network is defined as

$$\Delta V_A = V_{A1} - V_{A2}$$

To assure that the comparator will always switch fully to V_{CC} and not be pulled down by the load the resistors, values should be chosen as follow:

$$R_{PULL-UP} \ll R_{LOAD}$$

Application Information (Continued)

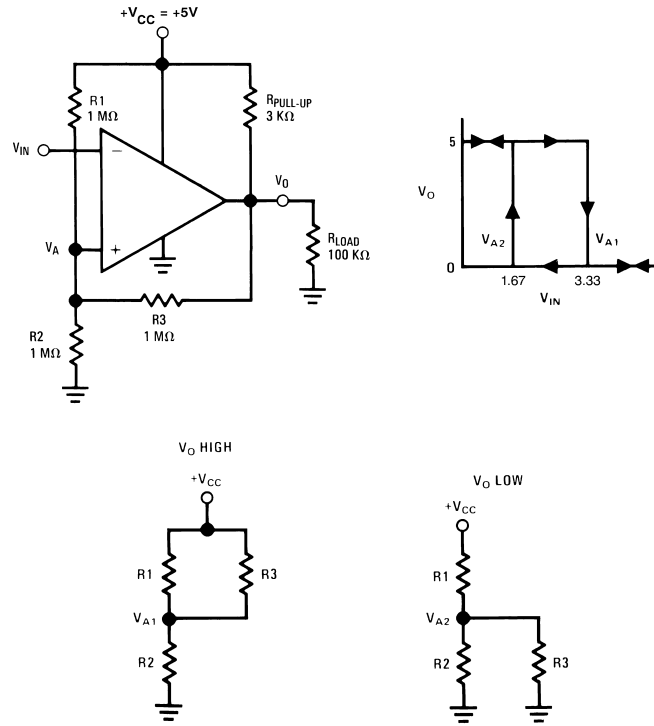

10135919

FIGURE 1. Inverting Comparator with Hysteresis

NON-INVERTING COMPARATOR WITH HYSTERESIS

A non inverting comparator with hysteresis requires a two resistor network, and a voltage reference (V_{REF}) at the inverting input. When V_{IN} is low, the output is also low. For the output to switch from low to high, V_{IN} must rise up to V_{IN1} where V_{IN1} is calculated by:

$$V_{IN1} = R1 * (V_{REF} / R2) + V_{REF}$$

When V_{IN} is high, the output is also high, to make the comparator switch back to its low state, V_{IN} must equal V_{REF} before V_A will again equal V_{REF} . V_{IN} can be calculated by

$$V_{IN2} = (V_{REF} (R1 + R2) - V_{CC} R1) / R2$$

The hysteresis of this circuit is the difference between V_{IN1} and V_{IN2} .

$$\Delta V_{IN} = V_{CC} R1 / R2$$

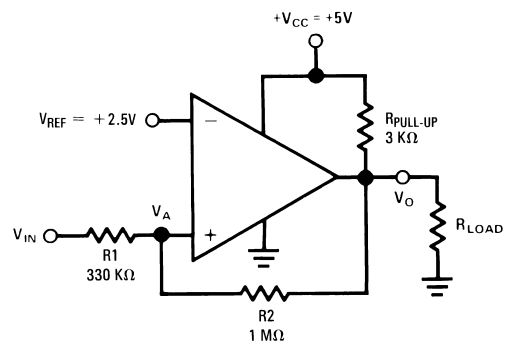

10135924

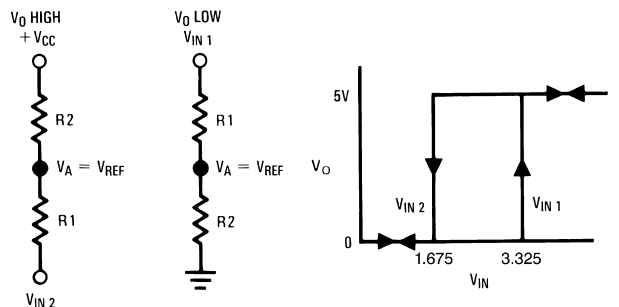

10135920

FIGURE 2. Non-Inverting Comparator with Hysteresis

Application Information (Continued)

CIRCUIT LAYOUT AND BYPASSING

The LMV7235/LMV7239 require high speed layout. Follow these layout guidelines:

1. Use printed circuit board with a good, unbroken low-inductance ground plane.
2. Place a decoupling capacitor (0.1 μ F ceramic surface mount capacitor) as close as possible to V_{CC} pin.
3. On the inputs and the output, keep lead lengths as short as possible to avoid unwanted parasitic feedback around the comparator. Keep inputs away from output.
4. Solder the device directly to the printed circuit board rather than using a socket.
5. For slow moving input signals, take care to prevent parasitic feedback. A small capacitor (1000pF or less) placed between the inputs can help eliminate oscillations in the transition region. This capacitor causes some degradation to t_{PD} when the source impedance is low.
6. The topside ground plane runs between the output and inputs.
7. Ground trace from the ground pin runs under the device up to the bypass capacitor, shielding the inputs from the outputs.

ZERO-CROSSING DETECTOR

The inverting input is connected to ground and the non-inverting input is connected to 100mVp-p signal. As the signal at the non-inverting input crosses 0V, the comparator's output changes state.

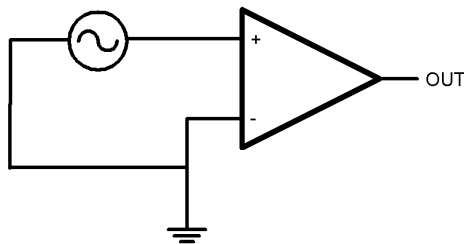

10135918

FIGURE 3. Zero-Crossing Detector

THRESHOLD DETECTOR

Instead of tying the inverting input to 0V, the inverting input can be tied to a reference voltage. The non-inverting input is connected to the input. As the input passes the V_{REF} threshold, the comparator's output changes state.

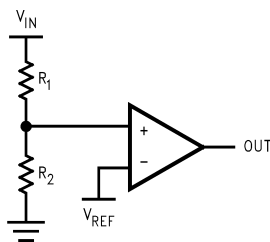

10135921

FIGURE 4. Threshold Detector

CRYSTAL OSCILLATOR

A simple crystal oscillator using the LMV7239 is shown below. Resistors R1 and R2 set the bias point at the comparator's non-inverting input. Resistors R3, R4 and C1 sets the inverting input node at an appropriate DC average level based on the output. The crystal's path provides resonant positive feedback and stable oscillation occurs. The output duty cycle for this circuit is roughly 50%, but it is affected by resistor tolerances and to a lesser extent by the comparator offset.

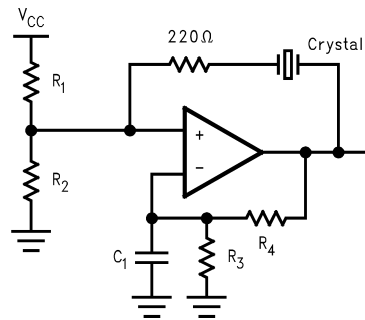

10135922

FIGURE 5. Crystal Oscillator

IR RECEIVER

The LMV7239 is an ideal candidate to be used as an infrared receiver. The infrared photo diode creates a current relative to the amount of infrared light present. The current creates a voltage across R_D . When this voltage level cross the voltage applied by the voltage divider to the inverting input, the output transitions.

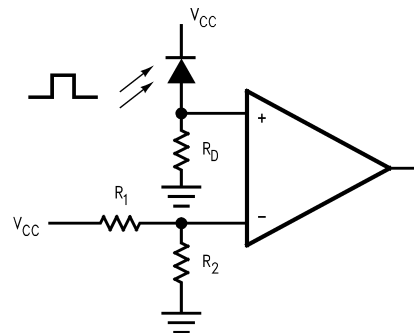

10135923

FIGURE 6. IR Receiver

Physical Dimensions inches (millimeters) unless otherwise noted

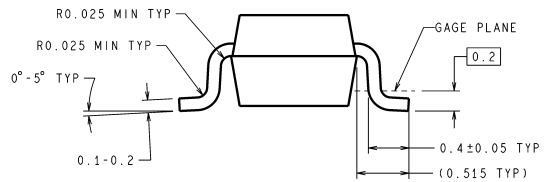
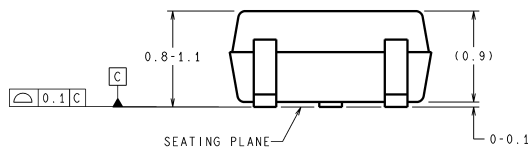
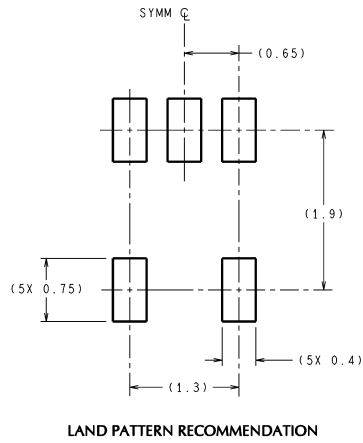
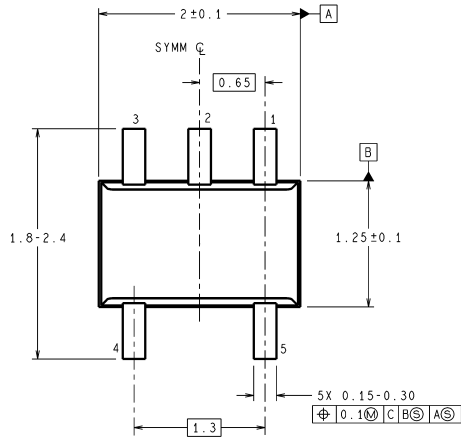

DIMENSIONS ARE IN MILLIMETERS

MAA05A (Rev C)

5-Pin SC70
NS Package Number MAA05A

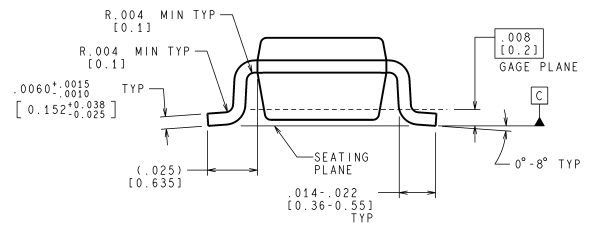
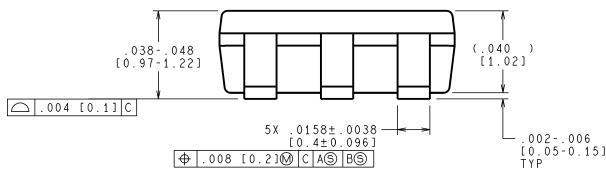
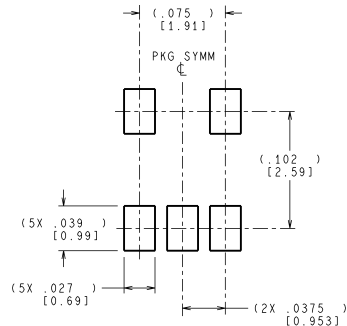
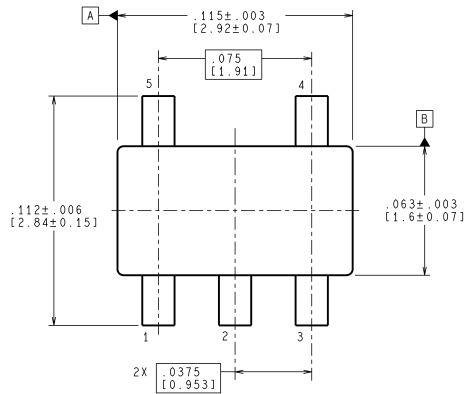

CONTROLLING DIMENSION IS INCH
VALUES IN [] ARE MILLIMETERS
DIMENSIONS IN () FOR REFERENCE ONLY

MF05A (Rev C)

5-Pin SOT23
NS Package Number MF05A

Notes

National does not assume any responsibility for use of any circuitry described, no circuit patent licenses are implied and National reserves the right at any time without notice to change said circuitry and specifications.

For the most current product information visit us at www.national.com.

LIFE SUPPORT POLICY

NATIONAL'S PRODUCTS ARE NOT AUTHORIZED FOR USE AS CRITICAL COMPONENTS IN LIFE SUPPORT DEVICES OR SYSTEMS WITHOUT THE EXPRESS WRITTEN APPROVAL OF THE PRESIDENT AND GENERAL COUNSEL OF NATIONAL SEMICONDUCTOR CORPORATION. As used herein:

- | | |
|--|---|
| <p>1. Life support devices or systems are devices or systems which, (a) are intended for surgical implant into the body, or (b) support or sustain life, and whose failure to perform when properly used in accordance with instructions for use provided in the labeling, can be reasonably expected to result in a significant injury to the user.</p> | <p>2. A critical component is any component of a life support device or system whose failure to perform can be reasonably expected to cause the failure of the life support device or system, or to affect its safety or effectiveness.</p> |
|--|---|

BANNED SUBSTANCE COMPLIANCE

National Semiconductor follows the provisions of the Product Stewardship Guide for Customers (CSP-9-111C2) and Banned Substances and Materials of Interest Specification (CSP-9-111S2) for regulatory environmental compliance. Details may be found at: www.national.com/quality/green.

Lead free products are RoHS compliant.



National Semiconductor
Americas Customer
Support Center
Email: new.feedback@nsc.com
Tel: 1-800-272-9959

National Semiconductor
Europe Customer Support Center
Fax: +49 (0) 180-530 85 86
Email: europe.support@nsc.com
Deutsch Tel: +49 (0) 69 9508 6208
English Tel: +44 (0) 870 24 0 2171
Français Tel: +33 (0) 1 41 91 8790

National Semiconductor
Asia Pacific Customer
Support Center
Email: ap.support@nsc.com

National Semiconductor
Japan Customer Support Center
Fax: 81-3-5639-7507
Email: jpn.feedback@nsc.com
Tel: 81-3-5639-7560

www.national.com