

**No Schtttoy,**  
**High Performance, Constant Current Switching Regulator**  
**For 9PCS White LED**

**General Description**

The LP3303 is a 1.0MHz PWM boost switching regulator designed for constant- current white LED driver applications. The LP3303 can drive a string of up to 8 white LEDs from a 3.6V in series, ensuring uniform brightness and eliminating several ballast resistors. The LP3303 implements a constant frequency 1.0MHz PWM control scheme. The high frequency PWM operation also saves board space by reducing external component sizes. To improve efficiency, the feedback voltage is set to 200mV, which reduces the power dissipation in the current setting resistor.

Highly integration and internal compensation network minimizes as 3 external component counts. Optimized operation frequency can meet the requirement of small LC filters value and low operation current with high efficiency.

**Ordering Information**

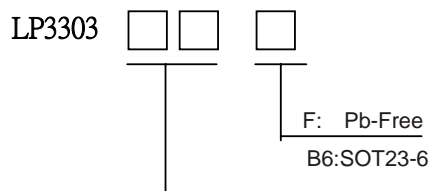

**Pin Configurations**

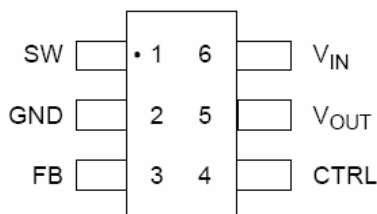

**Features**

- ✧ High Efficiency: 86%
- ✧ 1.2MHzFixed-Frequency PWM Operation
- ✧ Maximum Output Voltage up to 28V
- ✧ Operating Range : 2.7V to 16V
- ✧ Shutdown Supply Current:<1uA
- ✧ Available in SOT23-6 Package
- ✧ Built-in Over Voltage Protection
- ✧ Minimize the External Component
- ✧ RoHS Compliant and 100% Lead (Pb)-Free

**Applications**

- ✧ WLED Backlight driver
- ✧ OLED Backlight driver
- ✧ PDA
- ✧ DSC
- ✧ Camera Flash WLED driver

**Typical Application Circuit**

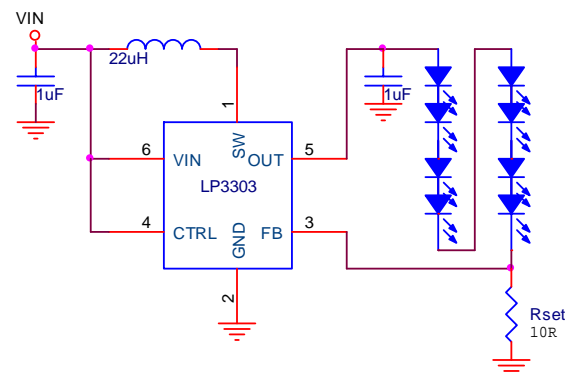

**Marking information**

Please view website.

Functional pin description

SOT-23-6	Pin Name	Pin Function
1	SW	Switch Pin. Connect this Pin to inductor and catch diode. Minimize the track area to reduce EMI.
2	GND	Ground Pin
3	FB	Feedback Reference Voltage Pin. Series connect a resistor between WLED and ground as a current sense. Sense the current feedback voltage to set the current rating.
4	CTRL	Chip Enable (Active High) and dimming Control pin.
5	OUT	Output Pin. Connect to output capacitor and LEDs. Minimize trace between this pin and output capacitor to reduce EMI.
6	VIN	Supply Input Voltage Pin. Bypass 1uF X5R or X7R capacitor to GND to reduce the input noise.

Function Block Diagram

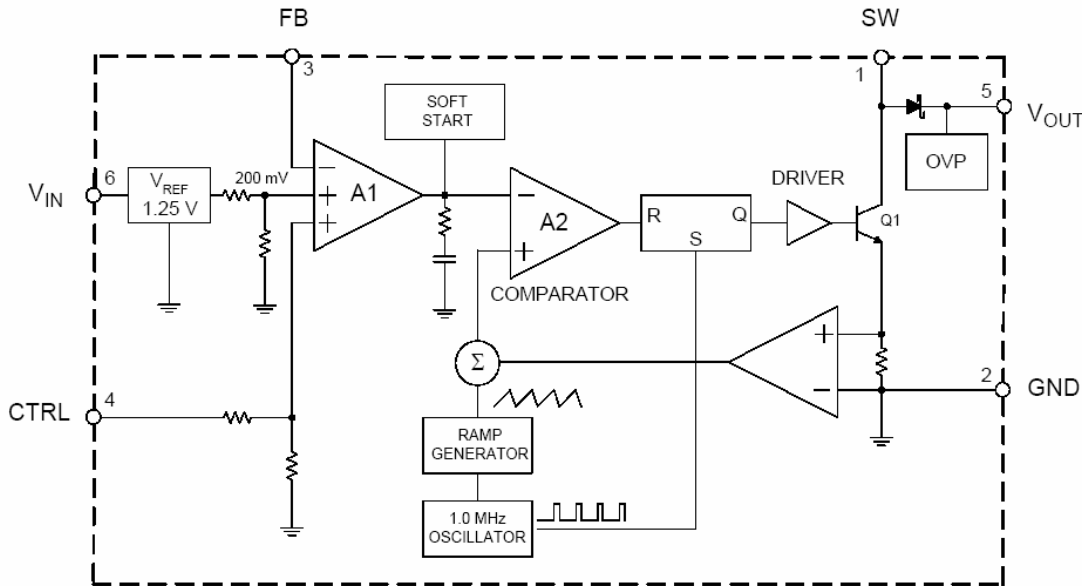

Absolute Maximum Ratings

- Supply Input Voltage(VIN)----- -0.3V to 16V
- LX Input Voltage ----- -0.3V to 36V
- OUT Pin Voltage----- -0.3V to 29V
- CTRL Pin Voltage----- -0.3V to 10V
- FB Pins ----- -0.3V to 2.0V
- Power Dissipation, Pd @ TA = 25°C SOT-23-5 ----- 0.455W
- Lead Temperature (Soldering, 10 sec.) ----- 260°C
- Operation Temperature Range ----- -40°C to 80°C
- Storage Temperature Range ----- -65°C to 150°C

### Electrical Characteristics

Parameter	Symbol	Test Condition	Min	Typ	Max	Units
<b>System Supply Input</b>						
Operation voltage Range	VDD		2.7		16	V
Under Voltage Lock Out	VDD			2.5		V
Supply Current	IDD	FB=0V, Switch		1	2.5	mA
Shut Down Current	IDD	VEN < 0.4V		0.1	1	uA
Line Regulation		VIN : 3.0~4.3V		3		%
<b>Oscillator</b>						
Operation Frequency	FOSC		0.9	1.0	1.2	MHz
Maximum Duty Cycle			90			%
Dimming Frequency			100		10k	Hz
Feedback Voltage	LP3303		191	200	210	mV
<b>MOSFET</b>						
On Resistance of MOSFET	RDS(ON)			0.5		Ω
Protection						
OVP Threshold	VOVP			29		V
OVP Sink Current				5		μ A
OCP				750		mA
Shut Down Voltage	VEN				0.4	V
Enable Voltage	VEN		1.5			V

Typical Operating Characteristics

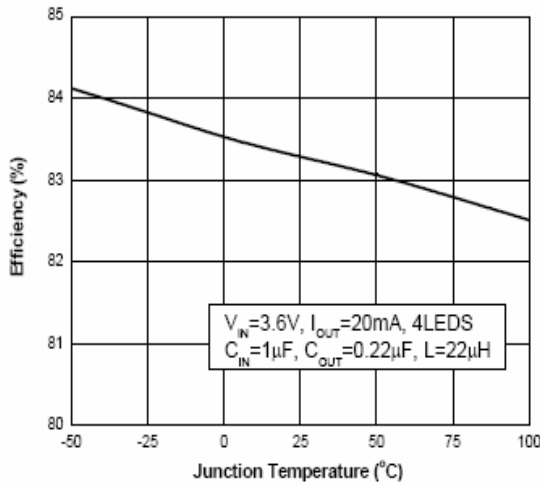

Figure 4. Efficiency vs. Junction Temperature

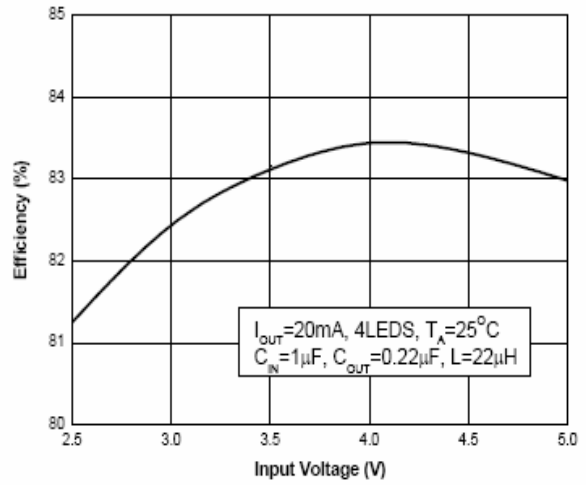

Figure 5. Efficiency vs. Input Voltage

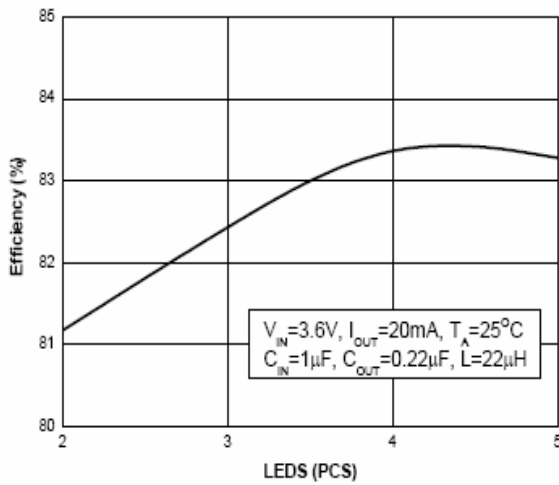

Figure 6. Efficiency vs. LED's Number

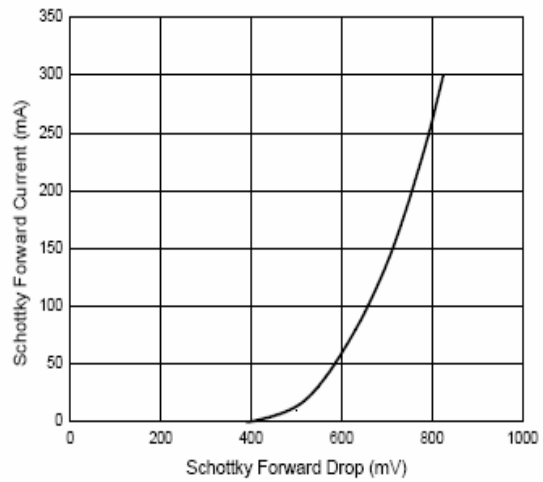

Figure 7. Schottky Forward Current vs. Schottky Forward Drop

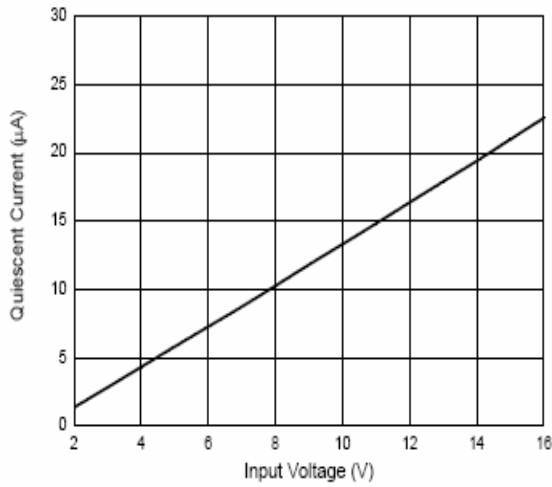

Figure 8. Shutdown Quiescent Current vs. Input Voltage

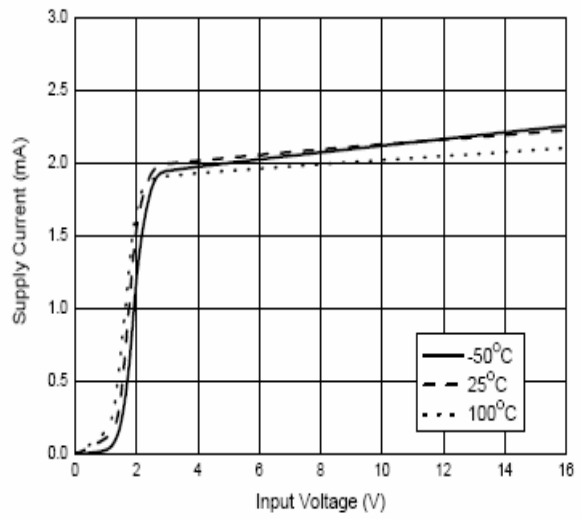

Figure 9. Supply Current vs. Input Voltage

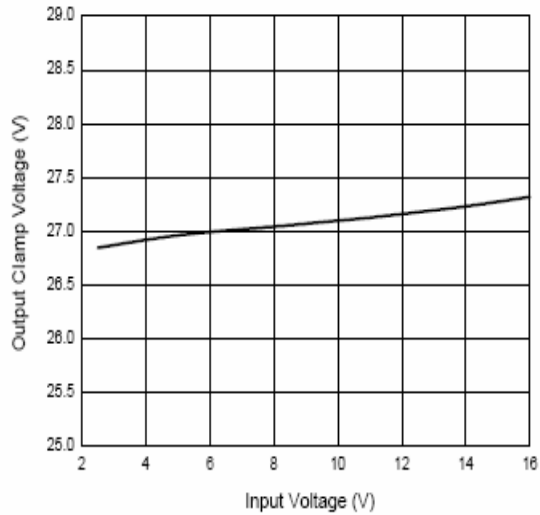

Figure 10. Output Clamp Voltage vs. Input Voltage

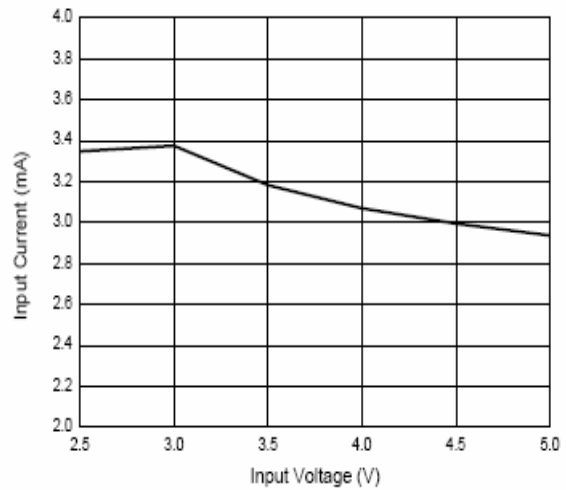

Figure 11. Input Current in Output Open Circuit vs. Input Voltage

Applications Information

LED Current Control

The LP3303 regulates the LED current by setting the current sense resistor (Rset) connecting to feedback and ground. The internal feedback reference voltage is 200mV. The LED current can be set from following equation easily.

$$I_{LED(mA)} = 200mV / R_{set}$$

In order to have an accurate LED current, precision resistors are preferred (1% is recommended). The table for Rset selection is shown below.

Rset Resistor Value selection

I <sub>LED</sub> (mA)	R <sub>SET</sub> (Ω)
20	10
15	13.3
12	16.6
10	20
5	40

Inductor Selection

The recommended value of inductor for 2 to 8 WLEDs applications are 4.7 to 22μH. Small size and better efficiency are the major concerns for portable device, such as LP3303 used for mobile phone. The inductor should have low core loss at 1.4MHz and low DCR for better efficiency. To avoid inductor saturation current rating should be considered.

Dimming control

a. Using a PWM Signal to CTRL Pin

For controlling the LED brightness, the LP3303 can perform the dimming control by applying a PWM signal to CTRL pin. The internal soft-start and wide range dimming frequency from 100Hz to 50KHz can insignificantly reduce audio noise when dimming. The average LED current is proportional to the PWM signal duty cycle. The magnitude of the PWM signal should be higher than the maximum enable voltage of CTRL pin, in order to let the dimming control perform correctly.

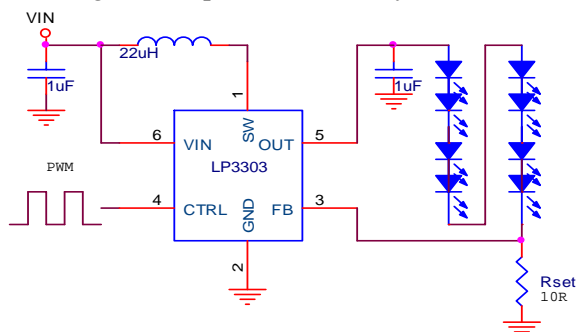

b. Using a DC Voltage

Using a variable DC voltage to adjust the brightness is a popular method in some applications. The dimming control using a DC voltage circuit is shown in Figure 4. According to the Superposition Theorem, as the DC voltage increases, the voltage contributed to VFB increases and the voltage drop on RSET decreases, i.e. the LED current decreases. For example, if the VDC range is from 0V to 2.8V, the selection of resistors in Figure 4 sets dimming control of LED current from 20mA to 0mA.

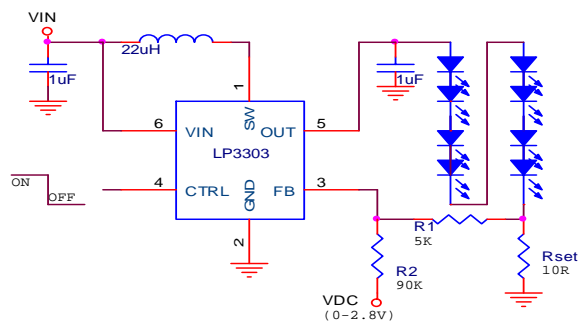

c. Using a Filtered PWM signal

Another common application is using a filtered PWM signal as an adjustable DC voltage for LED dimming control. A filtered PWM signal acts as the DC voltage to regulate the output current. The recommended application circuit is shown in the Figure 6. In this circuit, the output ripple depends on the frequency of PWM signal. For smaller output voltage ripple (<100mV), the recommended frequency of 2.8V PWM signal should be above 2kHz. To fix the frequency of PWM signal and change the duty cycle of PWM signal can get different output current. According to the application circuit of Figure 5, output current is from 20.5mA to 5.5mA by adjusting the PWM duty cycle from 10% to 90%.

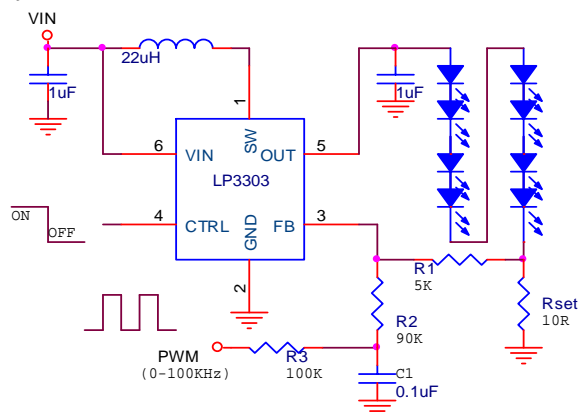

Packing information

SOT23-6

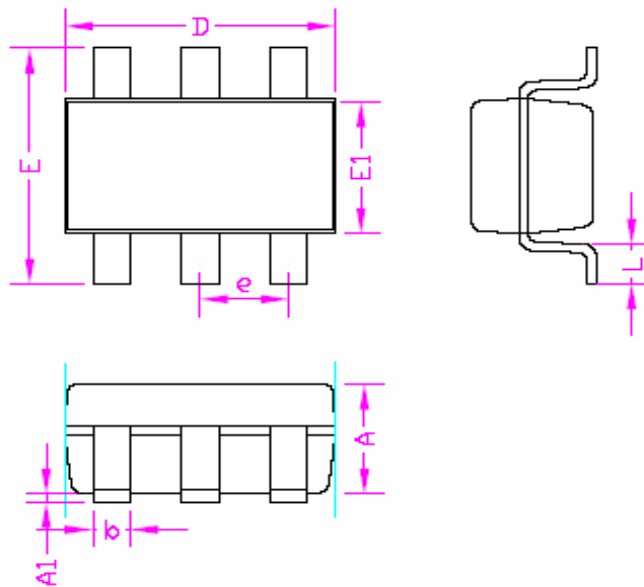

SYMBOLS	MILLIMETERS		INCHES	
	MIN.	MAX.	MIN.	MAX.
A	-	1.45	-	0.057
A1	0.00	0.15	0.000	0.006
b	0.30	0.50	0.012	0.020
D	2.90		0.114	
E1	1.60		0.063	
e	0.95		0.037	
E	2.60	3.00	0.102	0.118
L	0.3	0.60	0.012	0.024