

TO-220



1 2 3

TO-263  
(D<sup>2</sup>PAK)



1 2 3

TO-220-5L



1 5

TO-263-5L  
(D<sup>2</sup>PAK)



1 5

**Pin Definition:**  
**TS39200**  
1. Input  
2. Ground (tab)  
3. Output

**Pin Definition:**

TS39201xx	TS39202	TS39203xx	TS39204xx	TS39205
1. Enable	1. Enable	1. Enable	1. Input	1. Input
2. Input	2. Input	2. Input	2. Enable	2. Enable
3. Ground	3. Ground	3. Ground	3. Output	3. Output
4. Output	4. Output	4. Output	4. N/C	4. Adjust
5. Flag	5. Adjust	5. Sense	5. Ground	5. Ground

### General Description

The TS39200/1/2/3/4/5 are 2A ultra low dropout linear voltage regulators that provide low voltage, high current output with a minimum of external components. The TS39200/1/2/3/4/5 offers extremely low dropout (typically 600mV at 2A) and low quiescent current (typically 30mA at 2A).

The TS39200/1/2/3/4/5 is ideal for PC add-in cards that need to convert from standard 3.3V to 2.5V or 2.5V to 1.8V. A guaranteed maximum dropout voltage of 500mV over all operating conditions allows the TS39200/1/2/3/4/5 to provide 2.5V from a supply as low as 3V, and 1.8V from a supply as low as 2.5V. The TS39200/1/2/3/4/5 also has fast transient response for heavy switching applications. The device requires only 47uF of output capacitor to maintain stability and achieve fast transient response.

On the TS39200/1/2/3/4/5, the enable pin may be tied to input voltage if it is not required for enable control.

### Features

- Dropout voltage typically 0.6V @Io=2A
- Output Current up to 2A
- Low Ground Current
- Extremely Fast Transient Response
- Current Limit & Thermal Shutdown
- Reversed Leakage & Reverse Battery Protection
- Error Flag Signals Output (TS39201 only)
- Adjustable Version (TS39202 & TS39205 only)
- Output Voltage Sense (TS39203 only)

### Application

- PowerPC™ Power Supplies
- Battery Powered Equipment
- Consumer and Personal Electronics
- High Efficiency Linear Power Supplies
- SMPS Post Regulator and DC to DC Modules
- High-efficiency Post Regulator for Switching Supply
- Low Voltage Microcontrollers and Digital Logic

### Ordering Information

Part No.	Package	Packing
TS39200CZxx C0	TO-220	50pcs / Tube
TS39200CMxx RN	TO-263	800pcs / 13" Reel
TS39201CZ5xx C0	TO-220-5L	50pcs / Tube
TS39201CM5xx RN	TO-263-5L	800pcs / 13" Reel
TS39202CZ5 C0	TO-220-5L	50pcs / Tube
TS39202CM5 RN	TO-263-5L	800pcs / 13" Reel
TS39203CZxx C0	TO-220-5L	50pcs / Tube
TS39203CMxx RN	TO-263-5L	800pcs / 13" Reel
TS39204CZxx C0	TO-220-5L	50pcs / Tube
TS39204CMxx RN	TO-263-5L	800pcs / 13" Reel
TS39205CZ5 C0	TO-220-5L	50pcs / Tube
TS39205CM5 RN	TO-263-5L	800pcs / 13" Reel

Note: Where **xx** denotes voltage option, available are **50**=5V, **33**=3.3V, **25**=2.5V, **18**=1.8V, **15**=1.5V  
Contact to factory for addition output voltage option.

### Absolute Maximum Rating (Note 1)

Supply Voltage	$V_{IN}$	-20V ~ +20	V
Enable Voltage	$V_{EN}$	+20	V
Storage Temperature Range	$T_{STG}$	-65 ~ +150	°C
Lead Soldering Temperature (260°C)		5	S
ESD		(Note 3)	

### Operating Rating (Note 2)

Operation Input Voltage	$V_{IN}$ (operate)	+2.25 ~ +16	V
Operation Enable Voltage	$V_{EN}$ (operate)	+2.25 ~ +16	V
Power Dissipation (Note 4)	$P_D$	Internally Limited	W
Operating Junction Temperature Range	$T_J$	-40 ~ +125	°C

### Electrical Characteristics

$V_{IN} = V_{OUT} + 1V$ ,  $V_{IN} = 2.5V$  for fixed reference output voltage,  $V_{enable} = 2.25V$ ,  $T_a = 25^\circ C$ , unless otherwise specified.

Parameter	Conditions	Min	Typ	Max	Unit	
Fixed Output Voltage	$10mA \leq I_L \leq 2A$ , $V_{O+1V} \leq V_{IN} \leq 8V$	$0.970 V_O $	$V_{OUT}$	$1.030 V_O $	V	
Fixed Reference Output Voltage	$I_L = 10mA$	$0.980 V_O $	1.24 ( $V_{REF}$ )	$1.020 V_O $	V	
Fixed Reference Output Voltage	$10mA \leq I_L \leq 2A$ , $2.5V \leq V_{IN} \leq 8V$	$0.970 V_O $		$1.030 V_O $		
Line Regulation	$I_L = 10mA$ , $V_{O+1V} \leq V_{IN} \leq 8V$	--	0.05	0.5	%	
Load Regulation	$V_{IN} = V_{out} + 1V$ , $10mA \leq I_L \leq 2A$	--	0.2	1.0	%	
Output Voltage Temp. Coefficient		--	40	100	ppm/°C	
Dropout Voltage (Note 5)	$\Delta V_{OUT} = -1\%$	$I_L = 100mA$	--	100	200	mV
		$I_L = 1A$	--	350	500	
		$I_L = 2A$	--	600	800	
Quiescent Current (Note 6)	$V_{IN} = V_{OUT} + 1V$	$I_L = 100mA$	--	3	5	mA
		$I_L = 1A$	--	10	20	
		$I_L = 2A$	--	20	50	
Current Limited	$V_{OUT} = 0$ , $V_{IN} = V_{OUT} + 1V$	2.3	2.7	--	A	

### Reference (TS39202/5)

Reference Voltage		$0.980 V_O $	1.24	$1.020 V_O $	
Reference Voltage	(Note 7)	$0.970 V_O $		$1.030 V_O $	V
Adjust Pin Bias Current		--	40	120	nA
Reference Voltage Temp. Coefficient	(Note 8)	--	20	--	ppm/°C
Adjust Pin Bias Current Temp. Coefficient		--	0.1	--	nA/°C

### Enable Input (TS39201/2/3/4/5)

Input Logic Voltage	Low (OFF)	--	--	0.8	V
	High (ON)	2.25	--	--	
Enable Pin Input Current	$V_{EN} = 2.25V$	--	--	75	uA
	$V_{EN} = 0.8V$	--	--	4	

### Electrical Characteristics (Continue)

#### Flag Output (TS39201)

Output Leakage Current	$V_{OH}=16V$	--	--	2	$\mu A$
Output Low Voltage (Note 9)	$V_{IN}=0.9 * V_{OUT}, I_{OL}=250\mu A$	--	--	400	mV
Upper Threshold Voltage	% of $V_{OUT}$	--	--	99	%
Lower Threshold Voltage	% of $V_{OUT}$	93	--	--	%
Hysteresis		--	1	--	%

#### Thermal Performance

Condition	Package type	Typ	Unit
Thermal Resistance Junction to Case	TO-220 / TO-220-5L	80	$^{\circ}C/W$
	TO-263 / TO-263-5L	80	

Note 1. Exceeding the absolute maximum ratings may be damaged the device.

Note 2. The device is not guaranteed to function outside its operating rating.

Note 3. Devices are ESD sensitive. Handling precautions recommended.

Note 4.  $P_{D(max)} = (T_{J(max)} - T_a) + \Theta_{JA}$ , where  $\Theta_{JA}$  depends upon the printed circuit layout. See "Applications Information".

Note 5. Output voltage temperature coefficient is  $\Delta V_{OUT (worst\ case)} + (T_{J(max)} - T_{J(MIN)})$  where  $T_{J(max)}$  is  $+125^{\circ}C$  and  $T_{J(MIN)}$  is  $-40^{\circ}C$ .

Note 6.  $V_{DROP} = V_{IN} - V_{OUT}$  when  $V_{OUT}$  decreases to 99% of its nominal output voltage with  $V_{IN} = V_{OUT} + 1$ . For output voltages below 2.5V, dropout voltage is the input-to-output voltage differential with the minimum input voltage being 2.5V. Minimum input operating voltage is 2.5V

Note 7.  $I_{GND}$  is the quiescent current.  $I_{IN} = I_{GND} + I_{OUT}$

Note 8.  $V_{EN} < 0.8V$ ,  $V_{IN} < 8V$  and  $V_{OUT} = 0$

Note 9. For 1.8V device,  $V_{IN} = 2.25V$  (device is in dropout)

#### Pin Description

Pin Configuration	Pin Description
Enable	TTL/COMS compatible input. Logic high is enable; logic low or open is shutdown
Input	Unregulated input: +16V maximum supply
Ground	Ground: Ground pin and TAB / heat sink are internally connected.
Output	Regulator output
Flag (fixed voltage)	Error Flag (output): Open-collector output. Active low indicates an output fault condition, if no used, leave open.
Feed Back (adjustable)	Adjustment input: Feedback input. Connect to resistive voltage-divider network.
Sense	Sense pin is the input to the error amplifier

### Functional Diagram

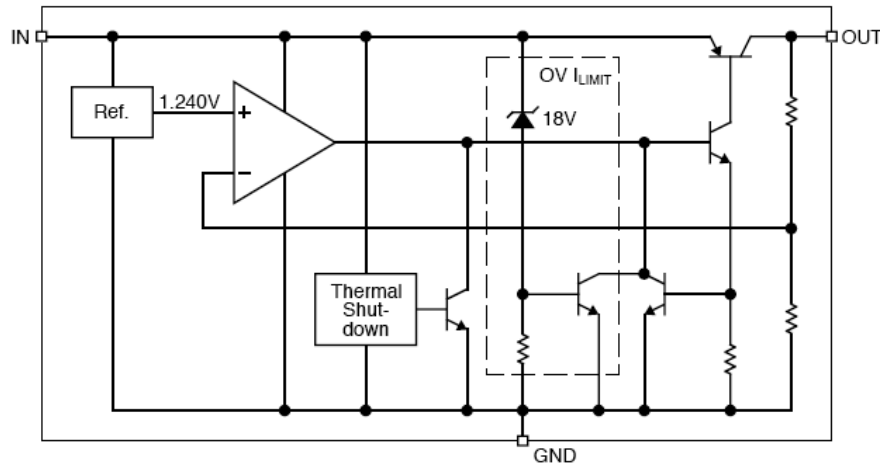

**TS39200 Fixed Regulator Block Diagram**

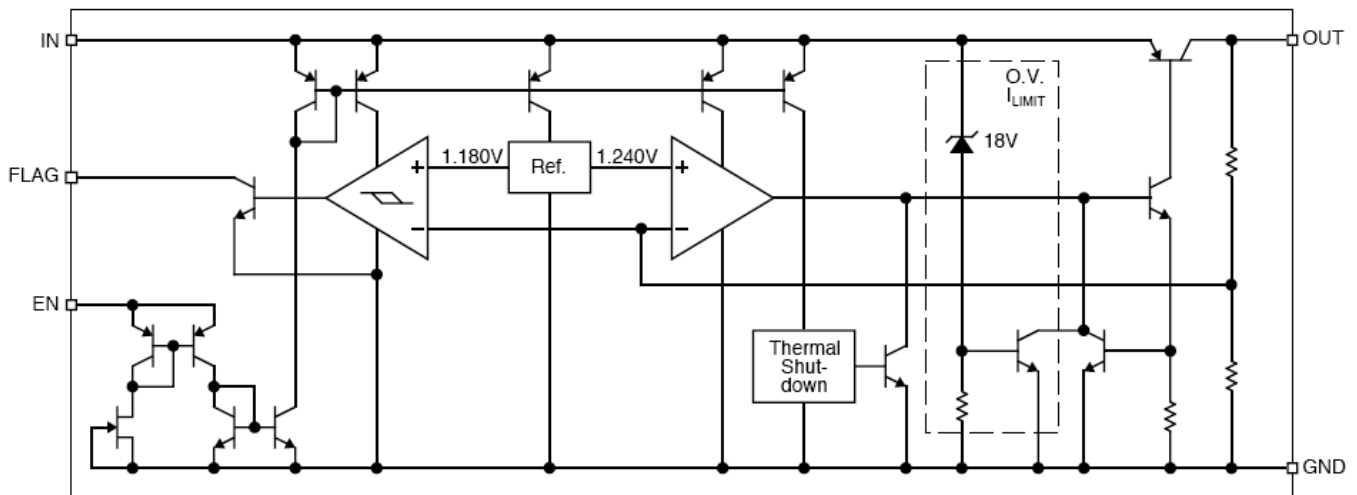

**TS39201/3/4 Fixed Regulator with Flag, Sense and Enable Block Diagram**

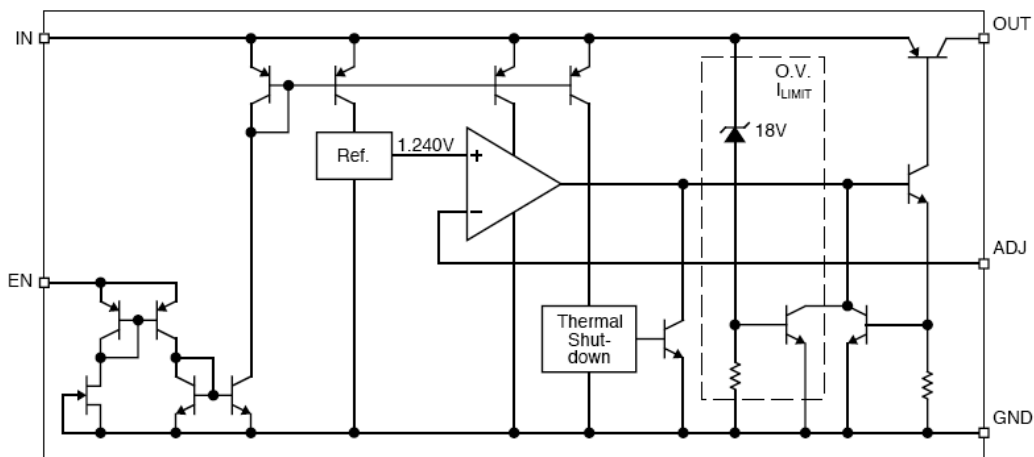

**TS39202/5 Adjustable Regulator Block Diagram**

### Application Information

The TS39200/1/2/3/4/5 are high performance with low dropout voltage regulator suitable for moderate to high current and voltage regulator application. Its 800mV dropout voltage at full load and over temperature makes it especially valuable in battery power systems and as high efficiency noise filters in post regulator applications. Unlike normal NPN transistor design, where the base to emitter voltage drop and collector to emitter saturation voltage limit the minimum dropout voltage, dropout performance of the PNP output of these devices is limited only by low  $V_{CE}$  saturation voltage. The TS39200/1/2/3/4/5 is fully protected from damage due to fault conditions. Linear current limiting is provided. Output current during overload conditions is constant. Thermal shutdown the device when the die temperature exceeds the maximum safe operating temperature. Transient protection allows device survival even when the input voltage spikes above and below nominal. The output structure of these regulators allows voltages in excess of the desired output voltage to be applied without reverse current flow.

### Output Capacitor Requirement

The TS39200/1/2/3/4/5 requires an output capacitor to maintain stability and improve transient response is necessary. The value of this capacitor is dependent upon the output current, lower currents allow smaller capacitors. TS39200/1/2/3/4/5 output capacitor selection is dependent upon the ESR of the output capacitor to maintain stability. When the output capacitor is 10uF or greater, the output capacitor should have an ESR less than 2Ω. This will improve transient response as well as promote stability. Ultra low ESR capacitors (<100mΩ), such as ceramic chip capacitors, may promote instability. These very low ESR levels may cause an oscillation and/or under damped transient response. A low ESR solid tantalum capacitor works extremely well and provides good transient response and stability over temperature aluminum electrolytes can also be used, as long as the ESR of the capacitor is <2Ω. The value of the output capacitor can be increased without limit. Higher capacitance values help to improve transient response and ripple rejection and reduce output noise.

### Input Capacitor Requirement

An input capacitor of 1uF or greater is recommended when the device is more than 4" away from the bulk AC supply capacitance or when the supply is a battery. Small, surface mount, ceramic chip capacitors can be used for bypassing. Larger values will help to improve ripple rejection by bypassing the input to the regulator, further improving the integrity of the output voltage.

### Minimum Load Current

The TS39200/1/2/3/4/5 is specified between finite loads. If the output current is too small leakage currents dominate and the output voltage rises. A 10mA minimum load current is necessary for proper regulation.

### Adjustable Regulator Design

The adjustable regulator versions (TS39202 & TS39205) is allow to programming the output voltage anywhere between 1.25 and the 16V maximum operating rating of the family.

Two resistors are used. Resistors can be quite large up to 1MΩ, because of the very high input impedance and low bias current of the sense comparator, the resistor values are calculated by:

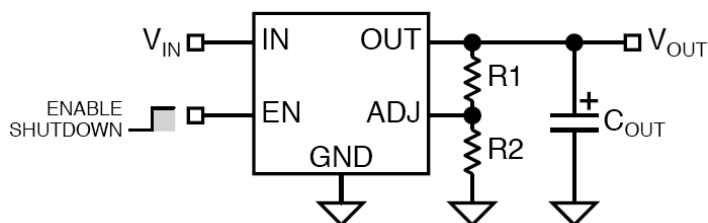

$$V_{OUT} = 1.240V \left( 1 + \frac{R1}{R2} \right)$$

Where  $V_{OUT}$  is the desired output voltage. Above application circuit shows component definition. Applications with widely varying load currents may scale the resistors to draw the minimum load current required for proper operation.

### Application Information (Continue)

#### Enable Input

TS39201/2/3/4/5 versions feature an active-high enable (EN) input that allows ON/OFF control of the regulator. Current drain reduces to “zero” when the device is shutdown, with only micro-amperes of leakage current. The EN input has TTL/CMOS compatible thresholds for simple interfacing with logic interfacing. EN may be directly tied to  $V_{IN}$  and pulled up to the maximum supply voltage.

#### Error Flag

TS39201 versions feature an Error Flag, which looks at the output voltage and signals an error condition when this voltage drops 5% below its expected value. The error flag is an open-collector output that pulls low under fault conditions. It may sink 10mA. Low output voltage signifies a number of possible problems, including an over-current fault (the device is in current limit) or low input voltage. The flag output is inoperative during over temperature shutdown conditions. A pull-up resistor from error flag to either  $V_{IN}$  or  $V_{OUT}$  is required for proper operation. For information regarding the minimum and maximum values of pull-up resistance, refer the graph as follow:

Error Flag Pull-ip Resistor

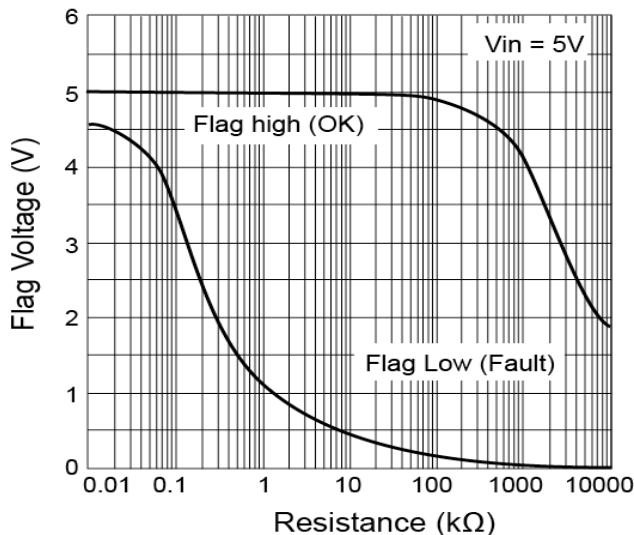

#### Transient Response and 3.3V to 2.5V or 2.5V to 1.8V Conversion

TS39200/1/2/3/4/5 has excellent transient response to variations in input voltage and load current. The device have been designed to respond quickly to load current variations and input voltage variations. Large output capacitors are not required to obtain this performance. A standard 10uF output capacitor, preferably tantalum, is all that is required. Larger values help to improve performance even further. By virtue of its low dropout voltage, this device does not saturate into dropout as readily as similar NPN base designs. When converting from 3.3V to 2.5V or 2.5V to 1.8V, the NPN based regulators are already operating in dropout, with typical dropout requirements of 1.2V or greater,. To convert down to 2.5V or 1.8V without operating in dropout, NPN based regulators require an input voltage of 3.7V at the very least. The TS39200/1/2/3/4/5 regulator will provide excellent performance with an input as low as 3.0V or 2.5V respectively. This gives the PNP based regulators a distinct advantage over older, NPN based linear regulators.

#### Output Sense

Sense pin can be connected to the load and traces the load voltage, TS39203/4 will adjust the output voltage to maintain the load at expected voltage.

### Application Information (Continue)

#### Thermal Characteristics

TS39200/1/2/3/4/5 linear regulators are simple to use, the most complicated design parameters to consider are thermal characteristics, thermal design requires the following application specification parameters:

- Maximum ambient temperature,  $T_A$
- Output current,  $I_{OUT}$
- Output voltage,  $V_{OUT}$
- Input voltage,  $V_{IN}$

Calculate the power dissipation of the regulator from these numbers and the device parameters from this datasheet, where the ground current is taken from data sheet.

$$P_D = (V_{IN} - V_{OUT}) \times I_{OUT} + V_{IN} \times I_{GND}$$

The heat sink thermal resistance is determined by:

$$\Theta_{SA} = (T_{J(MAX)} - T_A) / P_D - (\Theta_{JC} + \Theta_{CS})$$

Where  $T_{J(MAX)} \leq 125^\circ\text{C}$  and  $\Theta_{CS}$  is between  $0^\circ\text{C}$  and  $2^\circ\text{C/W}$ . The heat sink may be significantly reduced in applications where the minimum input voltage is known and is large compared with the dropout voltage and distribute the heat between this resistor and the regulator. The low dropout properties of vertical PNP regulators allow significant reductions in regulator power dissipation and the associated heat sink without compromising performance. When this technique is employed, a capacitor of at least 1uF is needed directly between the input and regulator ground.

#### Typical Application Circuit

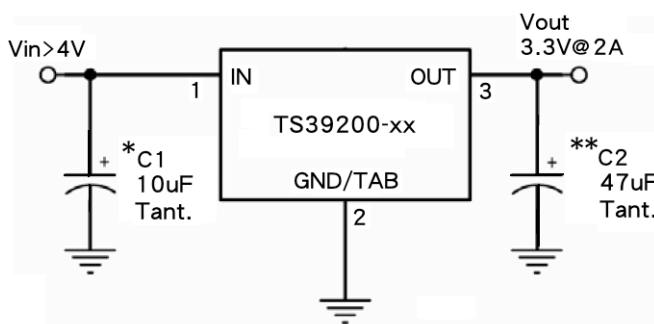

2.5V/2A Regulator

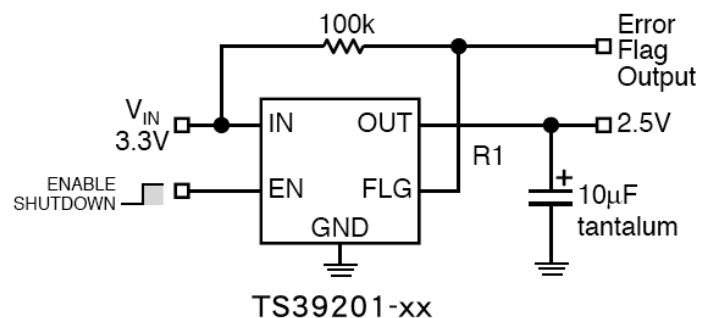

2.5V/2A Regulator with Error Flag

### TO-220 Mechanical Drawing

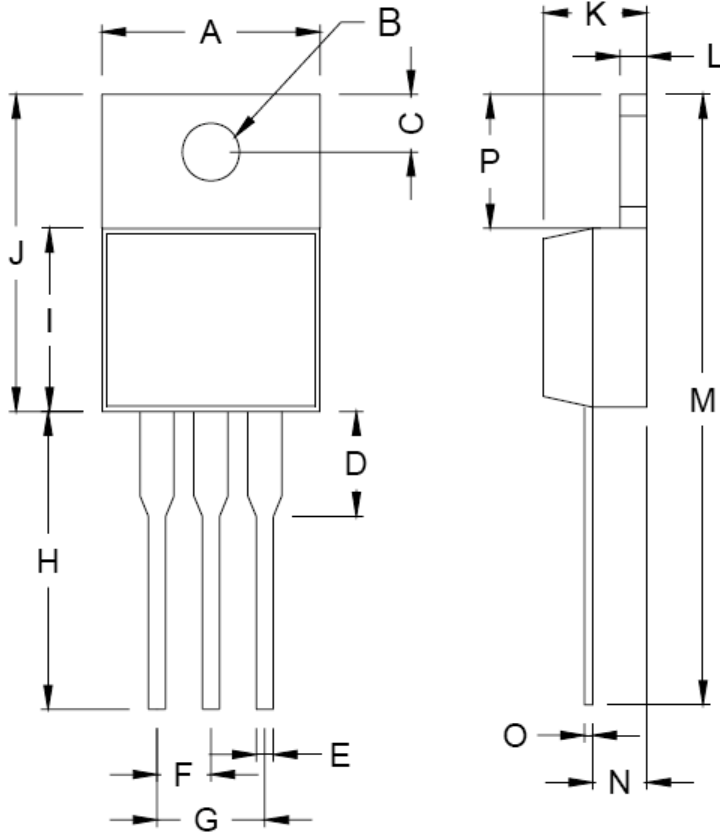

TO-220 DIMENSION				
DIM	MILLIMETERS		INCHES	
	MIN	MAX	MIN	MAX
A	10.000	10.500	0.394	0.413
B	3.740	3.910	0.147	0.154
C	2.440	2.940	0.096	0.116
D	-	6.350	-	0.250
E	0.381	1.106	0.015	0.040
F	2.345	2.715	0.092	0.058
G	4.690	5.430	0.092	0.107
H	12.700	14.732	0.500	0.581
I	8.382	9.017	0.330	0.355
J	14.224	16.510	0.560	0.650
K	3.556	4.826	0.140	0.190
L	0.508	1.397	0.020	0.055
M	27.700	29.620	1.060	1.230
N	2.032	2.921	0.080	0.115
O	0.255	0.610	0.010	0.024
P	5.842	6.858	0.230	0.270



### TO-263 Mechanical Drawing

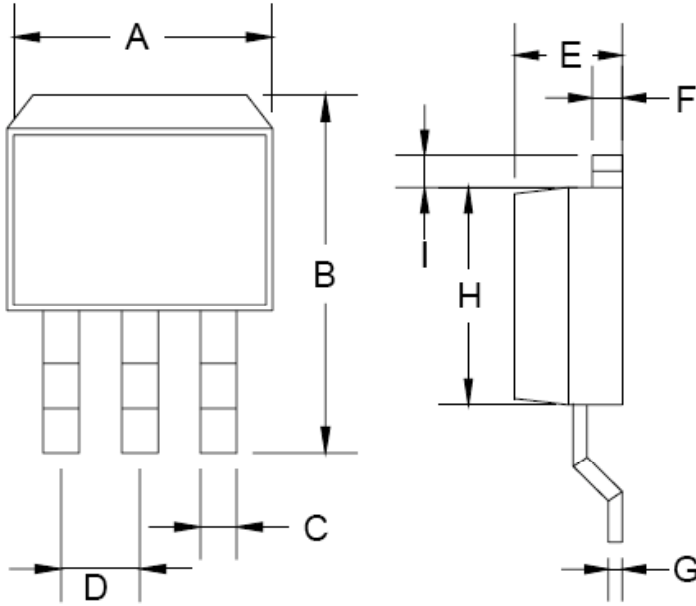

TO-263 DIMENSION				
DIM	MILLIMETERS		INCHES	
	MIN	MAX	MIN	MAX
A	10.000	10.500	0.394	0.413
B	14.605	15.875	0.575	0.625
C	0.508	0.991	0.020	0.039
D	2.420	2.660	0.095	0.105
E	4.064	4.830	0.160	0.190
F	1.118	1.400	0.045	0.055
G	0.450	0.730	0.018	0.029
H	8.280	8.800	0.325	0.346
I	1.140	1.400	0.044	0.055
J	1.480	1.520	0.058	0.060

### TO-220-5L Mechanical Drawing

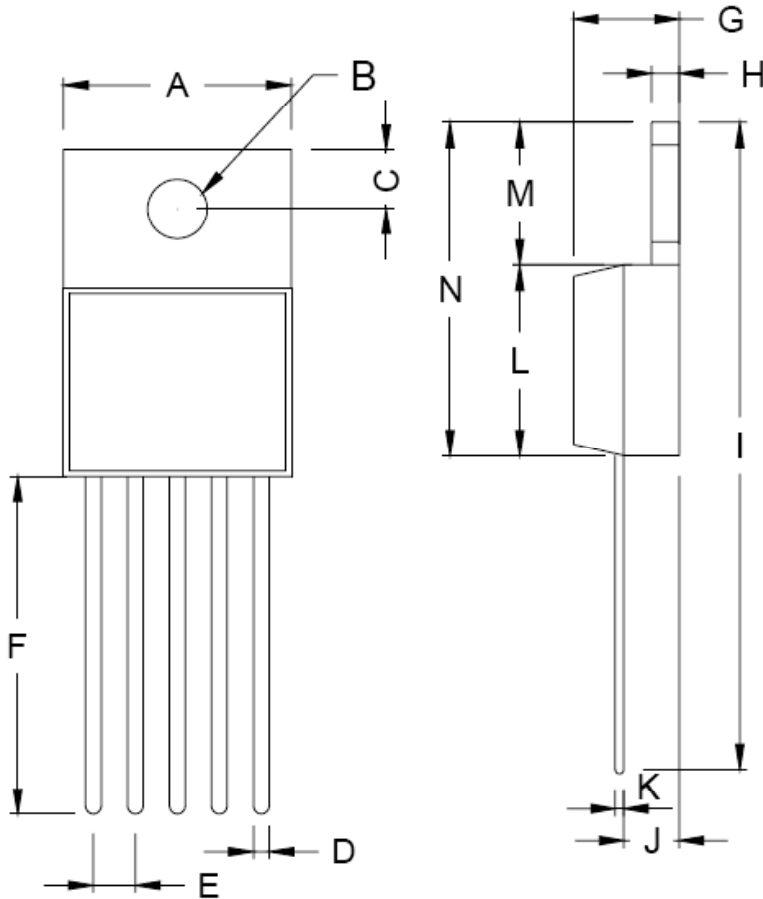

TO-220-5L DIMENSION				
DIM	MILLIMETERS		INCHES	
	MIN	MAX	MIN	MAX
A	10.00	10.50	0.394	0.413
B	3.240	4.440	0.128	0.175
C	2.440	2.940	0.096	0.116
D	0.260	1.020	0.010	0.040
E	1.570	1.830	0.062	0.072
F	13.31	14.13	0.524	0.556
G	4.475	5.225	0.176	0.206
H	1.170	1.370	0.046	0.054
I	27.60	29.44	1.087	1.159
J	2.175	2.925	0.086	0.115
K	0.297	0.477	0.012	0.019
L	8.280	8.800	0.326	0.346
M	6.010	6.510	0.237	0.256
N	14.29	15.31	0.563	0.603

### TO-263-5L Mechanical Drawing

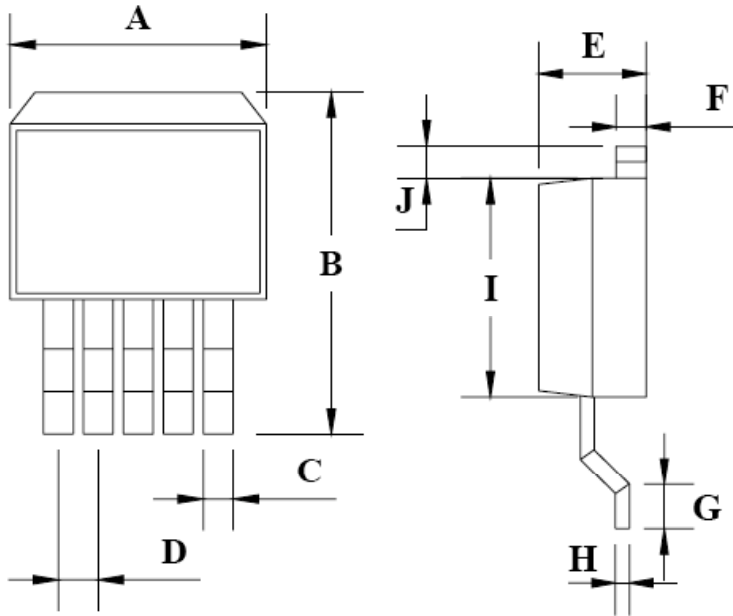

TO-263-5L DIMENSION				
DIM	MILLIMETERS		INCHES	
	MIN	MAX	MIN	MAX
A	9.70	10.54	0.382	0.415
B	14.60	15.87	0.575	0.625
C	0.69	0.94	0.027	0.037
D	1.524	2.032	0.060	0.080
E	4.30	4.70	0.169	0.185
F	1.22	1.40	0.048	0.055
G	2.24	2.82	0.088	0.111
H	0.36	0.56	0.014	0.022
I	8.50	9.20	0.330	0.362
J	1.40 MAX		0.055 MAX	

# TS39200/1/2/3/4/5

## 2A Ultra Low Dropout Voltage Regulator with Multi-Function

### Notice

Specifications of the products displayed herein are subject to change without notice. TSC or anyone on its behalf, assumes no responsibility or liability for any errors or inaccuracies.

Information contained herein is intended to provide a product description only. No license, express or implied, to any intellectual property rights is granted by this document. Except as provided in TSC's terms and conditions of sale for such products, TSC assumes no liability whatsoever, and disclaims any express or implied warranty, relating to sale and/or use of TSC products including liability or warranties relating to fitness for a particular purpose, merchantability, or infringement of any patent, copyright, or other intellectual property right.

The products shown herein are not designed for use in medical, life-saving, or life-sustaining applications. Customers using or selling these products for use in such applications do so at their own risk and agree to fully indemnify TSC for any damages resulting from such improper use or sale.