

NEGATIVE ADJUSTABLE VOLTAGE REGULATOR

IP137K / LM137K
IP137AK / LM137AK
IP137HVK / LM137HVK
IP137AHVK / LM137AHVK
IP337K / LM337K
IP337AK / LM337AK
IP337HVK / LM337HVK
IP337AHVK / LM337AHVK

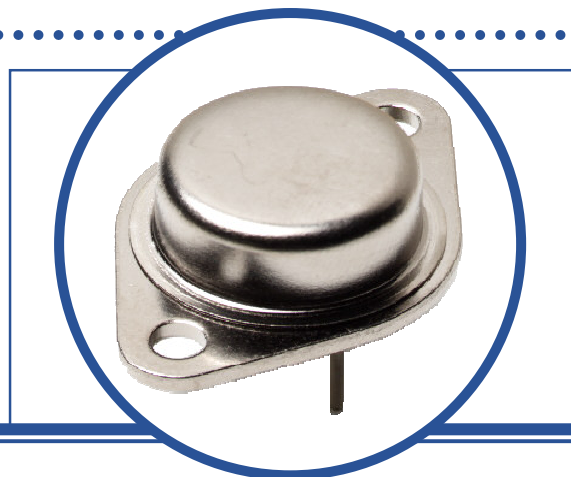

FEATURES

- 1.5A Output Current Guaranteed
- Internal Thermal Overload Protection
- Output Short Circuit Protected
- Hermetic Metal TO3 Package
- Screening Options Available

APPLICATIONS

- Adjustable Power Supplies
- System Power Supplies
- Precision Voltage / Current Regulators

DESCRIPTION

The 137/337 Series regulators are adjustable 3 terminal voltage regulators capable of supplying in excess of -1.5A over an output voltage range of -1.2V to -37V (HV Series, -47V). The regulators are exceptionally easy to apply requiring only 2 external resistors to set the output voltage and 1 output capacitor for frequency compensation.

Every effort has been made to make these devices easy to use and difficult to damage. Internal current limiting and power limiting coupled with true thermal limiting prevents damage due to overloads or shorts, even if the regulators are not fastened to a heat sink.

ABSOLUTE MAXIMUM RATINGS (T_C = 25°C unless otherwise stated)

V _I - V _O	Input – Output Voltage Differential	Standard	40V
		HV Series	50V
I _O	Output Current	Internally Limited	
P _D	Power Dissipation	Internally Limited	
T _J	Operating Junction Temperature Range	137 Series	-55 to +150°C
		337 Series	0 to +125°C
T _{stg}	Storage Temperature Range	-65 to +150°C	

THERMAL PROPERTIES

Symbols	Parameters	Min.	Typ.	Max.	Units
R _{θJC}	Thermal Resistance, Junction To Case			3	°C/W

** This datasheet supersedes document 2831

Semelab Limited reserves the right to change test conditions, parameter limits and package dimensions without notice. Information furnished by Semelab is believed to be both accurate and reliable at the time of going to press. However Semelab assumes no responsibility for any errors or omissions discovered in its use. Semelab encourages customers to verify that datasheets are current before placing orders.



A subsidiary of
TT electronics plc.

NEGATIVE ADJUSTABLE VOLTAGE REGULATOR

ELECTRICAL CHARACTERISTICS(1)(3) ($T_C = 25^\circ\text{C}$ unless otherwise stated)

LM137, IP137, LM137HV, IP137HV							
Symbols	Parameters	Test Conditions	Min.	Typ	Max.	Units	
V_{REF}	Reference Voltage	$I_{OUT} = 10\text{mA}$	-1.225	-1.250	-1.275	V	
		$10\text{mA} \leq I_{OUT} \leq I_{MAX}$, $P \leq P_{MAX}$, $3\text{V} \leq (V_{IN} - V_{OUT}) \leq V_{MAX}$	• -1.200	-1.250	-1.300		
$\frac{\Delta V_{OUT}}{\Delta V_{IN}}$	Line Regulation (2)	$3\text{V} \leq (V_{IN} - V_{OUT}) \leq V_{MAX}$, $I_{OUT} = 10\text{mA}$		0.010	0.020	%V	
			•	0.020	0.050		
$\frac{\Delta V_{OUT}}{\Delta I_{OUT}}$	Load Regulation (2)(3)	$10\text{mA} \leq I_{OUT} \leq I_{MAX}$	$V_{OUT} \leq 5\text{V}$		15	25	mV
			$V_{OUT} \geq 5\text{V}$		0.3	0.5	%
			$V_{OUT} \leq 5\text{V}$	•	20	50	mV
			$V_{OUT} \geq 5\text{V}$	•	0.3	1.0	%
	Thermal Regulation	$V_{IN} = -14.58\text{V}$, $I_{OUT} = 1.5\text{A}$, $P_D = 20\text{W}$, $T_A = 25^\circ\text{C}$, 10ms Pulse		0.002	0.02	%/W	
	Ripple Rejection	$V_{OUT} = -10\text{V}$, $f = 120\text{Hz}$	$C_{ADJ} = 0$		60		dB
			$C_{ADJ} = 10\mu\text{F}$	• 66	77		
I_{ADJ}	Adjust Pin Current		•	65	100	μA	
ΔI_{ADJ}	Adjust Pin Current Change	$10\text{mA} \leq I_{OUT} \leq I_{MAX}$	•	0.5	5		
		$3\text{V} \leq (V_{IN} - V_{OUT}) \leq 40\text{V}$	•	2	5		
		$3\text{V} \leq (V_{IN} - V_{OUT}) \leq 50\text{V}$ (HV Series)	•	3	6		
I_{MIN}	Minimum Load Current	$(V_{IN} - V_{OUT}) \leq 40\text{V}$	•	2.5	5	mA	
		$(V_{IN} - V_{OUT}) \leq 10\text{V}$	•	1.2	3		
I_{CL}	Current Limit	$(V_{IN} - V_{OUT}) \leq 15\text{V}$	•	1.5	2.2	A	
		$(V_{IN} - V_{OUT}) = 40\text{V}$	•	0.24	0.4		
		$(V_{IN} - V_{OUT}) = 50\text{V}$ (HV Series)	•	0.2	0.4		0.8
$\frac{\Delta V_{OUT}}{\Delta \text{TEMP}}$	Temperature Stability		•	0.6		%	
$\frac{\Delta V_{OUT}}{\Delta \text{TIME}}$	Long Term Stability	$T_A = 125^\circ\text{C}$, 1000Hrs		0.3	1.0		
e_n	RMS Output Noise (% of V_{OUT})	$T_A = 25^\circ\text{C}$, $10\text{Hz} \leq f \leq 10\text{KHz}$		0.003			

Notes

The • denotes the specifications which apply over the full operating temperature range.

- (1) Test conditions unless otherwise stated: $V_{IN} - V_{OUT} = 5\text{V}$, $I_{OUT} = 0.5\text{A}$, $P_{MAX} = 20\text{W}$, $I_{MAX} = 1.5\text{A}$
- (2) Regulation is measured at constant junction temperature, using pulse testing at a low duty cycle. Changes in output voltage due to heating effects are covered under thermal regulation specifications. Load regulation is measured at V_8 below the bottom of the package.
- (3) $V_{MAX} = 40\text{V}$ for LM137, IP137, LM137A, IP137A, LM337, IP337, LM337A, IP337A
 $V_{MAX} = 50\text{V}$ for LM137HV, IP137HV, LM137AHV, IP137AHV, LM337HV, IP337HV, LM337AHV, IP337AHV

NEGATIVE ADJUSTABLE VOLTAGE REGULATOR

ELECTRICAL CHARACTERISTICS(1)(3) ($T_C = 25^\circ\text{C}$ unless otherwise stated)

LM137A, IP137A, LM137AHV, IP137AHV							
Symbols	Parameters	Test Conditions	Min.	Typ	Max.	Units	
V_{REF}	Reference Voltage	$I_{OUT} = 10\text{mA}$	-1.238	-1.250	-1.262	V	
		$10\text{mA} \leq I_{OUT} \leq I_{MAX}$, $P \leq P_{MAX}$, $3\text{V} \leq (V_{IN} - V_{OUT}) \leq V_{MAX}$	● -1.220	-1.250	-1.280		
$\frac{\Delta V_{OUT}}{\Delta V_{IN}}$	Line Regulation (2)	$3\text{V} \leq (V_{IN} - V_{OUT}) \leq V_{MAX}$, $I_{OUT} = 10\text{mA}$		0.005	0.010	%V	
			●	0.010	0.030		
$\frac{\Delta V_{OUT}}{\Delta I_{OUT}}$	Load Regulation (2)(3)	$10\text{mA} \leq I_{OUT} \leq I_{MAX}$	$V_{OUT} \leq 5\text{V}$		5	25	mV
			$V_{OUT} \geq 5\text{V}$		0.1	0.5	%
			$V_{OUT} \leq 5\text{V}$	●	10	50	mV
			$V_{OUT} \geq 5\text{V}$	●	0.2	1.0	%
	Thermal Regulation	$V_{IN} = -14.58\text{V}$, $I_{OUT} = 1.5\text{A}$, $P_D = 20\text{W}$, $T_A = 25^\circ\text{C}$, 10ms Pulse		0.002	0.02	%/W	
	Ripple Rejection	$V_{OUT} = -10\text{V}$, $f = 120\text{Hz}$	$C_{ADJ} = 0$	60	66	dB	
			$C_{ADJ} = 10\mu\text{F}$	● 70	80		
I_{ADJ}	Adjust Pin Current		●	65	100	μA	
ΔI_{ADJ}	Adjust Pin Current Change	$10\text{mA} \leq I_{OUT} \leq I_{MAX}$	●	0.2	2		
		$3\text{V} \leq (V_{IN} - V_{OUT}) \leq 40\text{V}$	●	1.0	5		
		$3\text{V} \leq (V_{IN} - V_{OUT}) \leq 50\text{V}$ (HV Series)	●	2	6		
I_{MIN}	Minimum Load Current	$(V_{IN} - V_{OUT}) \leq 40\text{V}$	●	2.5	5	mA	
		$(V_{IN} - V_{OUT}) \leq 10\text{V}$	●	1.2	3		
I_{CL}	Current Limit	$(V_{IN} - V_{OUT}) \leq 15\text{V}$	●	1.5	2.2	A	
		$(V_{IN} - V_{OUT}) = 40\text{V}$	●	0.24	0.4		
		$(V_{IN} - V_{OUT}) = 50\text{V}$ (HV Series)	●	0.2	0.4		
$\frac{\Delta V_{OUT}}{\Delta \text{TEMP}}$	Temperature Stability		●	0.6	1.5	%	
$\frac{\Delta V_{OUT}}{\Delta \text{TIME}}$	Long Term Stability	$T_A = 125^\circ\text{C}$, 1000Hrs		0.3	1.0		
e_n	RMS Output Noise (% of V_{OUT})	$T_A = 25^\circ\text{C}$, $10\text{Hz} \leq f \leq 10\text{KHz}$		0.003			

Notes

The ● denotes the specifications which apply over the full operating temperature range.

- Test conditions unless otherwise stated: $V_{IN} - V_{OUT} = 5\text{V}$, $I_{OUT} = 0.5\text{A}$, $P_{MAX} = 20\text{W}$, $I_{MAX} = 1.5\text{A}$
- Regulation is measured at constant junction temperature, using pulse testing at a low duty cycle. Changes in output voltage due to heating effects are covered under thermal regulation specifications. Load regulation is measured at V_s below the bottom of the package.
- $V_{MAX} = 40\text{V}$ for LM137, IP137, LM137A, IP137A, LM337, IP337, LM337A, IP337A
 $V_{MAX} = 50\text{V}$ for LM137HV, IP137HV, LM137AHV, IP137AHV, LM337HV, IP337HV, LM337AHV, IP337AHV

NEGATIVE ADJUSTABLE VOLTAGE REGULATOR

ELECTRICAL CHARACTERISTICS(1)(3) ($T_C = 25^\circ\text{C}$ unless otherwise stated)

LM337, IP337, LM337HV, IP337HV							
Symbols	Parameters	Test Conditions	Min.	Typ	Max.	Units	
V_{REF}	Reference Voltage	$I_{OUT} = 10\text{mA}$	-1.213	-1.250	-1.287	V	
		$10\text{mA} \leq I_{OUT} \leq I_{MAX}$, $P \leq P_{MAX}$, $3\text{V} \leq (V_{IN} - V_{OUT}) \leq V_{MAX}$	• -1.200	-1.250	-1.300		
$\frac{\Delta V_{OUT}}{\Delta V_{IN}}$	Line Regulation (2)	$3\text{V} \leq (V_{IN} - V_{OUT}) \leq V_{MAX}$, $I_{OUT} = 10\text{mA}$		0.010	0.040	%V	
			•	0.020	0.070		
$\frac{\Delta V_{OUT}}{\Delta I_{OUT}}$	Load Regulation (2)(3)	$10\text{mA} \leq I_{OUT} \leq I_{MAX}$	$V_{OUT} \leq 5\text{V}$		15	50	mV
			$V_{OUT} \geq 5\text{V}$		0.3	1.0	%
			$V_{OUT} \leq 5\text{V}$	•	20	70	mV
			$V_{OUT} \geq 5\text{V}$	•	0.3	1.5	%
	Thermal Regulation	$V_{IN} = -14.58\text{V}$, $I_{OUT} = 1.5\text{A}$, $P_D = 20\text{W}$, $T_A = 25^\circ\text{C}$, 10ms Pulse		0.003	0.04	%/W	
	Ripple Rejection	$V_{OUT} = -10\text{V}$, $f = 120\text{Hz}$	$C_{ADJ} = 0$		60		dB
			$C_{ADJ} = 10\mu\text{F}$	•	66	77	
I_{ADJ}	Adjust Pin Current		•	65	100	μA	
ΔI_{ADJ}	Adjust Pin Current Change	$10\text{mA} \leq I_{OUT} \leq I_{MAX}$	•	0.5	5		
		$3\text{V} \leq (V_{IN} - V_{OUT}) \leq 40\text{V}$	•	2	5		
		$3\text{V} \leq (V_{IN} - V_{OUT}) \leq 50\text{V}$ (HV Series)	•	3	6		
I_{MIN}	Minimum Load Current	$(V_{IN} - V_{OUT}) \leq 40\text{V}$	•	2.5	10	mA	
		$(V_{IN} - V_{OUT}) \leq 10\text{V}$	•	1.0	6		
I_{CL}	Current Limit	$(V_{IN} - V_{OUT}) \leq 15\text{V}$	•	1.5	2.2	3.5	A
		$(V_{IN} - V_{OUT}) = 40\text{V}$	•	0.15	0.4		
		$(V_{IN} - V_{OUT}) = 50\text{V}$ (HV Series)	•	0.1	0.4	0.8	
$\frac{\Delta V_{OUT}}{\Delta \text{TEMP}}$	Temperature Stability		•	0.6		%	
$\frac{\Delta V_{OUT}}{\Delta \text{TIME}}$	Long Term Stability	$T_A = 125^\circ\text{C}$, 1000Hrs		0.3	1.0		
e_n	RMS Output Noise (% of V_{OUT})	$T_A = 25^\circ\text{C}$, $10\text{Hz} \leq f \leq 10\text{KHz}$		0.003			

Notes

The • denotes the specifications which apply over the full operating temperature range.

- Test conditions unless otherwise stated: $V_{IN} - V_{OUT} = 5\text{V}$, $I_{OUT} = 0.5\text{A}$, $P_{MAX} = 20\text{W}$, $I_{MAX} = 1.5\text{A}$
- Regulation is measured at constant junction temperature, using pulse testing at a low duty cycle. Changes in output voltage due to heating effects are covered under thermal regulation specifications. Load regulation is measured at V_6 below the bottom of the package.
- $V_{MAX} = 40\text{V}$ for LM137, IP137, LM137A, IP137A, LM337, IP337, LM337A, IP337A
 $V_{MAX} = 50\text{V}$ for LM137HV, IP137HV, LM137AHV, IP137AHV, LM337HV, IP337HV, LM337AHV, IP337AHV

NEGATIVE ADJUSTABLE VOLTAGE REGULATOR

ELECTRICAL CHARACTERISTICS(1)(3) ($T_C = 25^\circ\text{C}$ unless otherwise stated)

LM337A, IP337A, LM337AHV, IP337AHV							
Symbols	Parameters	Test Conditions	Min.	Typ	Max.	Units	
V_{REF}	Reference Voltage	$I_{OUT} = 10\text{mA}$	-1.238	-1.250	-1.262	V	
		$10\text{mA} \leq I_{OUT} \leq I_{MAX}$, $P \leq P_{MAX}$, $3\text{V} \leq (V_{IN} - V_{OUT}) \leq V_{MAX}$	● -1.220	-1.250	-1.280		
$\frac{\Delta V_{OUT}}{\Delta V_{IN}}$	Line Regulation (2)	$3\text{V} \leq (V_{IN} - V_{OUT}) \leq V_{MAX}$, $I_{OUT} = 10\text{mA}$		0.005	0.010	%V	
			●	0.010	0.030		
$\frac{\Delta V_{OUT}}{\Delta I_{OUT}}$	Load Regulation (2)(3)	$10\text{mA} \leq I_{OUT} \leq I_{MAX}$	$V_{OUT} \leq 5\text{V}$		5	25	mV
			$V_{OUT} \geq 5\text{V}$		0.1	0.5	%
			$V_{OUT} \leq 5\text{V}$	●	10	50	mV
			$V_{OUT} \geq 5\text{V}$	●	0.2	1.0	%
	Thermal Regulation	$V_{IN} = -14.58\text{V}$, $I_{OUT} = 1.5\text{A}$, $P_D = 20\text{W}$, $T_A = 25^\circ\text{C}$, 10ms Pulse		0.002	0.02	%/W	
	Ripple Rejection	$V_{OUT} = -10\text{V}$, $f = 120\text{Hz}$	$C_{ADJ} = 0$	60	66	dB	
			$C_{ADJ} = 10\mu\text{F}$	● 70	80		
I_{ADJ}	Adjust Pin Current		●	65	100	μA	
ΔI_{ADJ}	Adjust Pin Current Change	$10\text{mA} \leq I_{OUT} \leq I_{MAX}$	●	0.2	2		
		$3\text{V} \leq (V_{IN} - V_{OUT}) \leq 40\text{V}$	●	1.0	5		
		$3\text{V} \leq (V_{IN} - V_{OUT}) \leq 50\text{V}$ (HV Series)	●	2	6		
I_{MIN}	Minimum Load Current	$(V_{IN} - V_{OUT}) \leq 40\text{V}$	●	2.5	5	mA	
		$(V_{IN} - V_{OUT}) \leq 10\text{V}$	●	1.2	3		
I_{CL}	Current Limit	$(V_{IN} - V_{OUT}) \leq 15\text{V}$	●	1.5	2.2	A	
		$(V_{IN} - V_{OUT}) = 40\text{V}$	●	0.24	0.4		
		$(V_{IN} - V_{OUT}) = 50\text{V}$ (HV Series)	●	0.2	0.4		
$\frac{\Delta V_{OUT}}{\Delta \text{TEMP}}$	Temperature Stability		●	0.6	1.5	%	
$\frac{\Delta V_{OUT}}{\Delta \text{TIME}}$	Long Term Stability	$T_A = 125^\circ\text{C}$, 1000Hrs		0.3	1.0		
e_n	RMS Output Noise (% of V_{OUT})	$T_A = 25^\circ\text{C}$, $10\text{Hz} \leq f \leq 10\text{KHz}$		0.003			

Notes

The ● denotes the specifications which apply over the full operating temperature range.

- Test conditions unless otherwise stated: $V_{IN} - V_{OUT} = 5\text{V}$, $I_{OUT} = 0.5\text{A}$, $P_{MAX} = 20\text{W}$, $I_{MAX} = 1.5\text{A}$
- Regulation is measured at constant junction temperature, using pulse testing at a low duty cycle. Changes in output voltage due to heating effects are covered under thermal regulation specifications. Load regulation is measured at V_s below the bottom of the package.
- $V_{MAX} = 40\text{V}$ for LM137, IP137, LM137A, IP137A, LM337, IP337, LM337A, IP337A
 $V_{MAX} = 50\text{V}$ for LM137HV, IP137HV, LM137AHV, IP137AHV, LM337HV, IP337HV, LM337AHV, IP337AHV

NEGATIVE ADJUSTABLE VOLTAGE REGULATOR

APPLICATIONS INFORMATION

High Stability Regulator

The output stability, load regulation, line regulation, thermal regulation, temperature drift, long term drift, and noise, can be improved by a factor of 6.6 over the standard regulator configuration. This assumes a zener has 20PPM/°C maximum drift and about 10 times lower noise than the regulator.

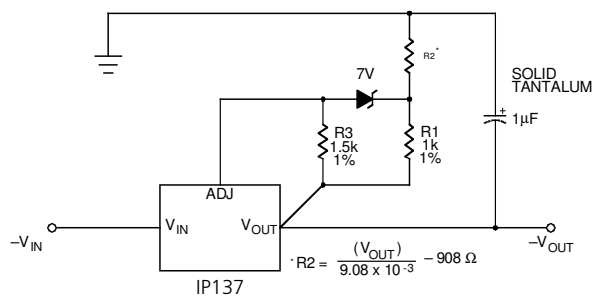

Multiple Tracking Regulators

In the application shown below, regulator #2 to "N" will track regulator #1 to within $\pm 24\text{mV}$ initially, and to $\pm 60\text{mV}$ over all load line, and temperature conditions.

If any regulator output is shorted to ground, all other outputs will drop to -2V . Load regulation of regulators #2 to "N" will be improved by $V_{OUT} / 1.25\text{V}$ compared to a standard, so regulator #1 should be the one which has the lowest load current.

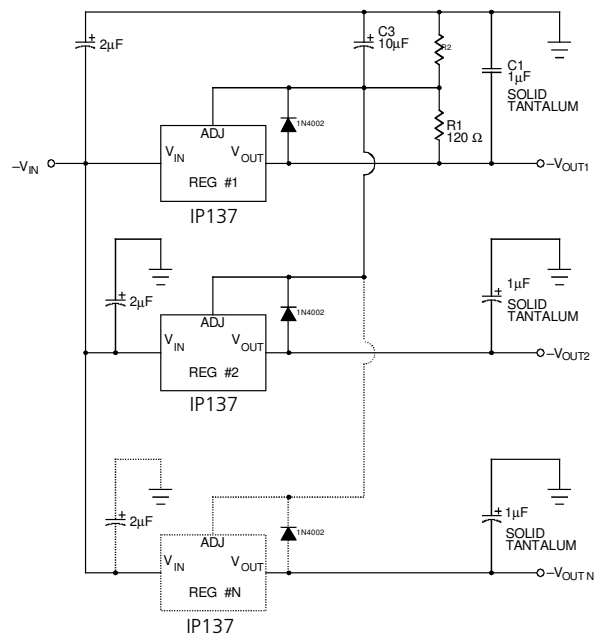

Dual Tracking Supply

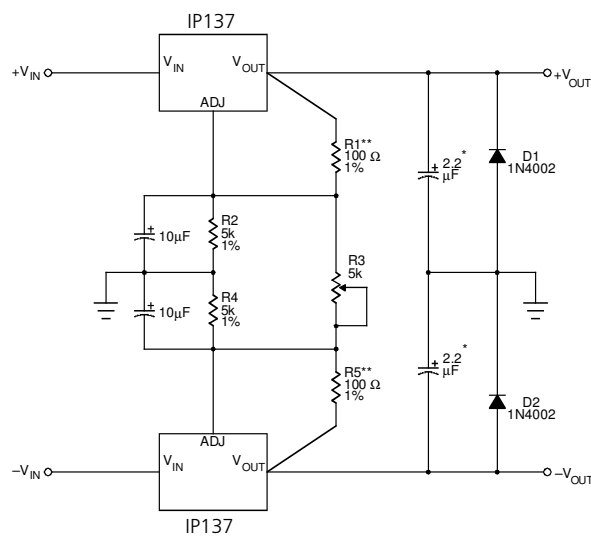

* Solid Tantalum
 ** R1 & R5 maybe trimmed slightly to improve tracking

Current Regulator

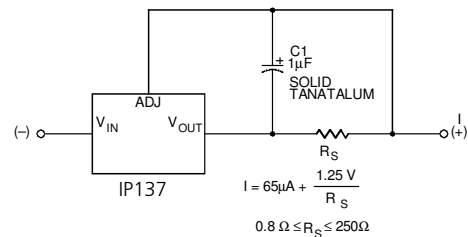

NEGATIVE ADJUSTABLE VOLTAGE REGULATOR

MECHANICAL DATA

Dimensions in mm (inches)

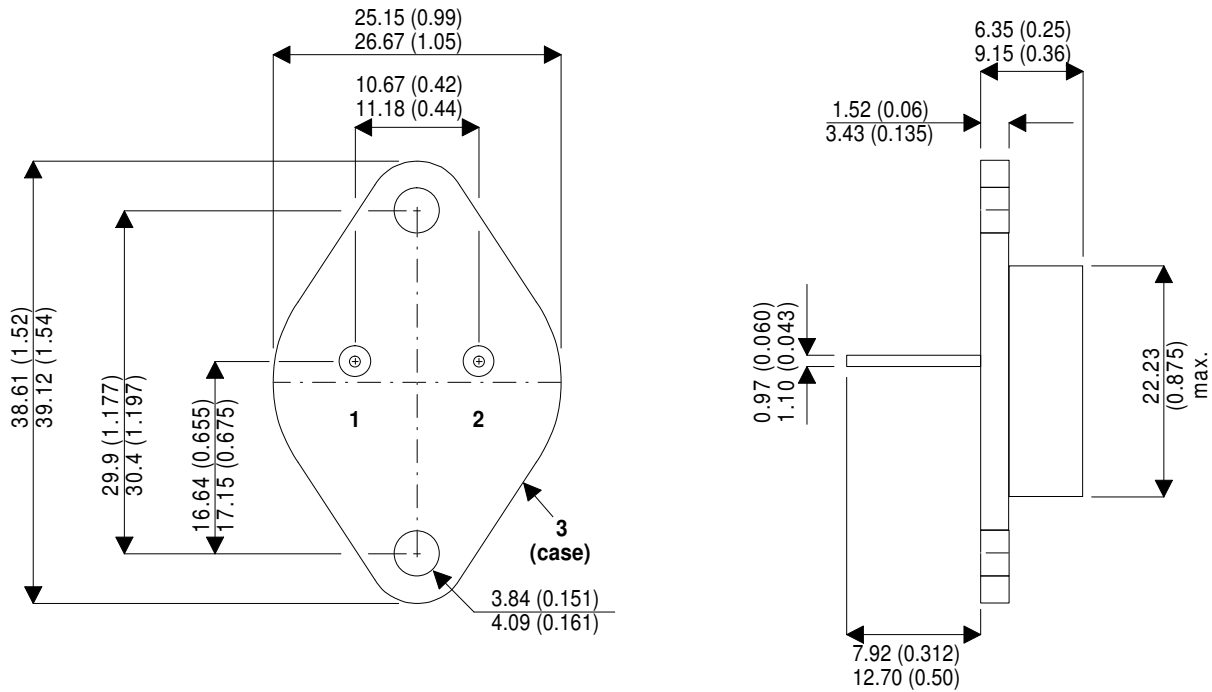

TO3 (TO-204AA)

Pin 1 = ADJ. Pin 2 = V_{OUT} Case = V_{IN}