

M62456FP

DIGITAL SOUND CONTROLLER

DESCRIPTION

The M62456FP Integrated Circuit is developed for audio-visual equipment. It being used for control sound in the power amplifier front stage. It has BASSBOOST circuit corresponding to BTL type driver.

FEATURES

- 24pin SSOP
- Build in diode clip circuit
- Corresponding to BTL type driver.
- Boost level control (3 steps)

PIN CONFIGURATION (TOP VIEW)

HPF1-1	1	M62456FP	24	HPF2-1
HPF1-2	2		23	HPF2-2
NF1	3		22	NF2
OUT1	4		21	OUT2
VCC	5		20	VEE
LRNF	6		19	CIN
B1	7		18	LROUT
B2	8		17	VR
LEVEL1	9		16	HPF3-1
LEVEL2	10		15	HPF3-2
GND	11		14	LPF1
INVLPF	12		13	LPF2

RECOMMENDED OPERATING CONDITIONS

- Supply voltage range •••VCC=+4.5 to 7.5V, VEE=-4.5 to -7.5V
- Rated supply voltage •••VCC=+7V, VEE=-7V

BLOCK DIAGRAM

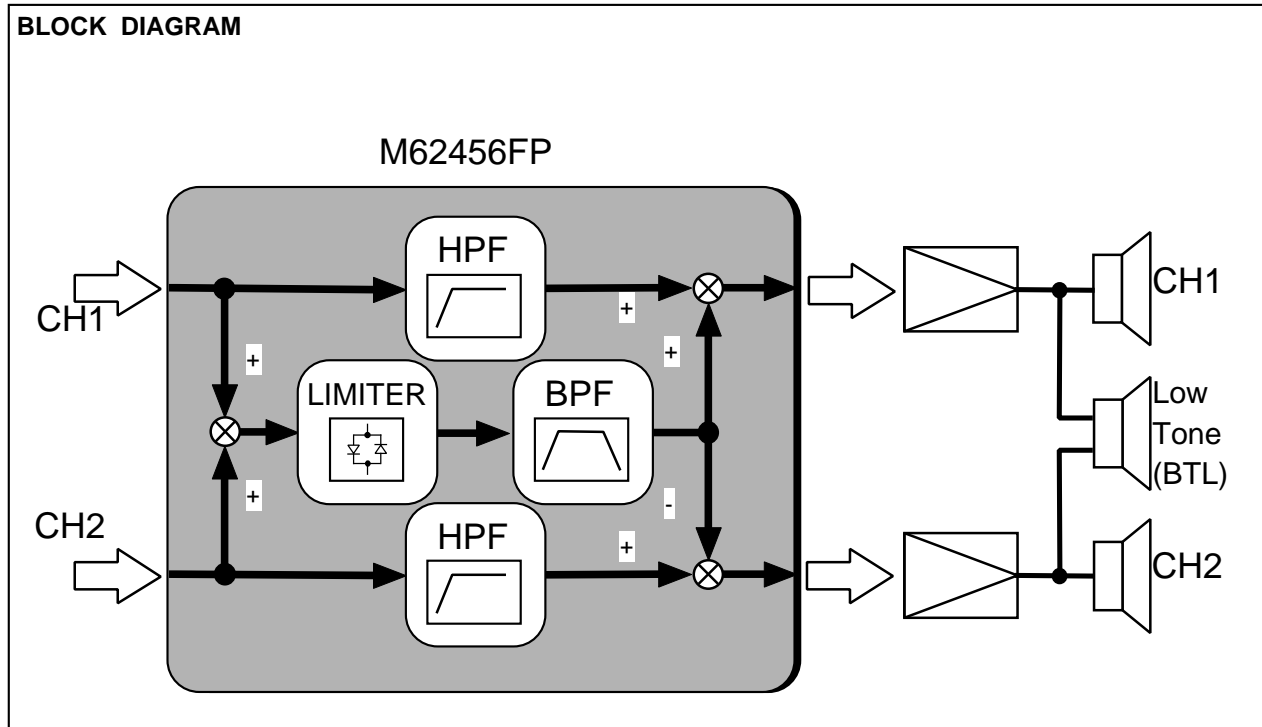

BLOCK DIAGRAM

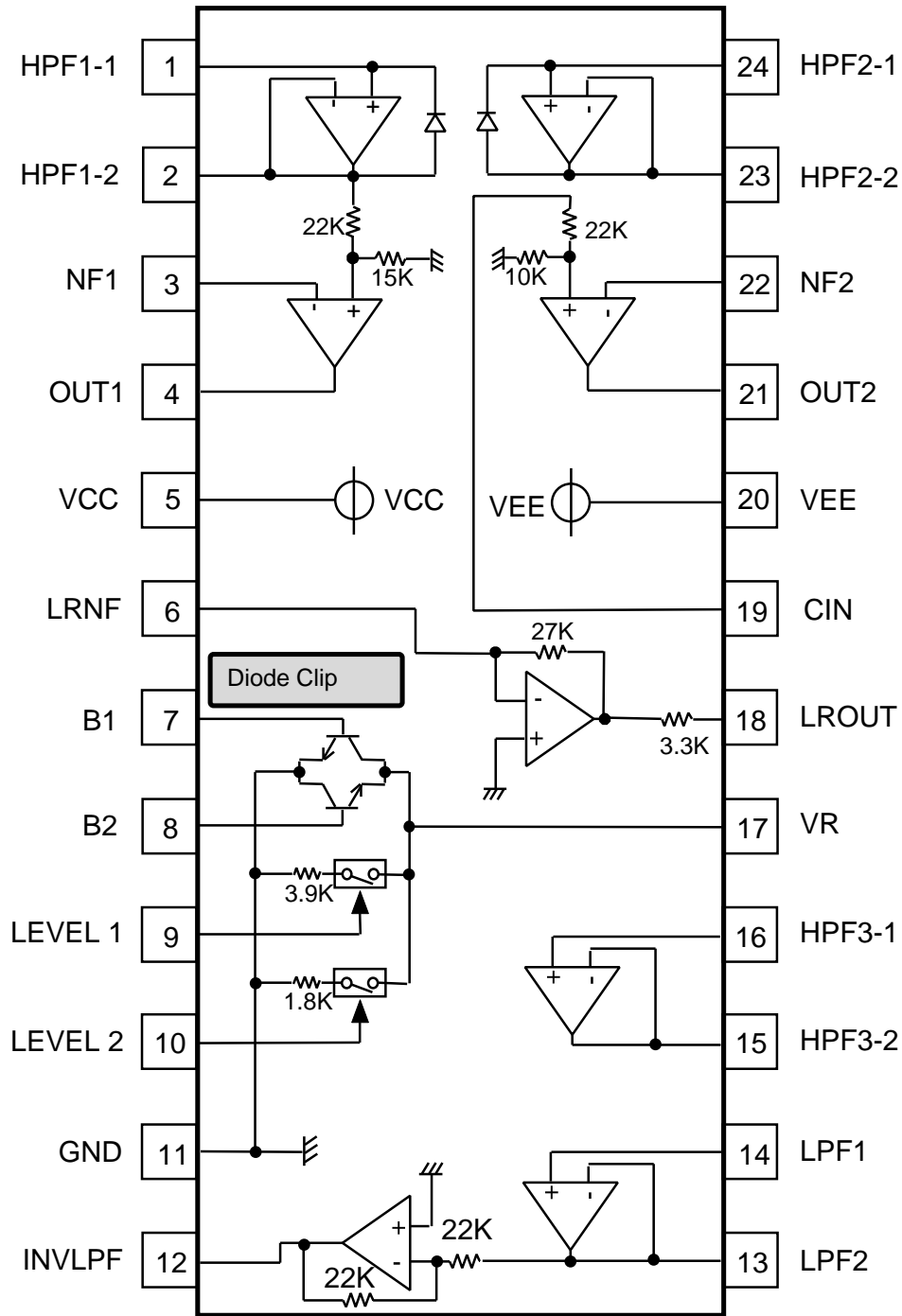

PIN DESCRIPTION

Pin No.	Symble	Function	DC voltage	Equivalent circuit
1	HPF1-1	Input pin of highpass filter 1	0V	
24	HPF2-1	Input pin of highpass filter 2		
2	HPF1-2	Output pin of highpass filter 1	0V	
23	HPF2-2	Output pin of highpass filter 2	0V	
3	NF1	Inverse Input 1	0V	
22	NF2	Inverse Input 2		
4	OUT1	Output 1	0V	
21	OUT2	Output 2		
5	Vcc	Positive Power Supply	7V	
6	LRNF	LR Mixing Amplifire input	0V	

PIN DESCRIPTION

Pin No.	Symble	Function	DC voltage	Equivalent circuit
7	B1	Adjustment of limiter amplitude	0V	
8	B2			
17	VR			
9	LEVEL1	LEVEL SW1	—	
10	LEVEL2	LEVEL SW2		
11	GND	Ground pin	0V	
12	INVLPF	Output of lowpass filter (inverse type)	0V	
13	LPF2	Output of lowpass filter	0V	
14	LPF1	Input of lowpass filter	0V	
16	HPF3-1	Input of highpass filter 3		
15	HPF3-2	Output of highpass filter 3	0V	

PIN DESCRIPTION

Pin No.	Symble	Function	DC voltage	Equivalent circuit
18	LROUT	Output of LR Mixing amplifier	0V	
19	CIN	Input of the output amplifier (non inverse)	0V	
20	VEE	Negative Power Supply	-7V	

ABSOLUTE MAXIMUM RATINGS

(Ta=25 , unless otherwise notes)

Symble	Parameter	Condition	Ratings	Unit
VCC	Supply voltage		+8	V
VEE			-8	V
Pd	Power dissipation	(on reference PCB)	950	mW
Kθ	Thermal derating	Ta ≥ 25°C	9.5	mW/°C
Topr	Operating temperature		-20 to +75	°C
Tstg	Storage temperature		-40 to +125	°C

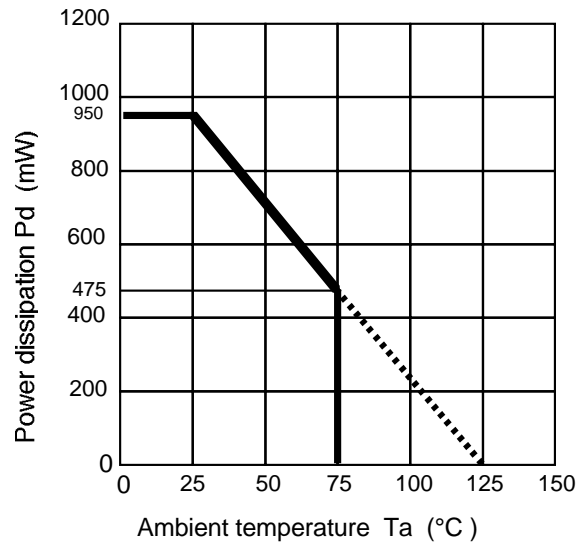

*Reference PCB

Size : 70mm * 70mm
 Thickness : 1.6mm
 Material : Glass ebonite
 Single side copper place

Copper plane dimension
 Thickness : 1.8um
 Width : 0.25mm
 Length : 30mm/lead

RECOMMENDED OPERATING CONDITIONS

Supply voltage range •••• VCC=+4.5 to 7.5V, VEE=-4.5 to -7.5V
 Rated supply voltage •••• VCC=+7V, VEE=-7V

ELECTRICAL CHARACTERISTICS

(Ta=25°C, VCC=7V, VEE=-7V, f=1kHz, Vin=-30dBV, unless otherwise notes)

Symbol	Parameter	Condition	Limits			Unit
			Min.	Typ.	Max.	
ICC	Curcuit current +	no signal	-	5	10	mA
IEE	Curcuit current -	no signal	-10	-5	-	mA
Gv	Gain		-2	0	2	dB
Vomax	Maximum output voltage	THD=1%	2.5	4	-	Vrms
Vno	Output noise voltage	IHF-A	-	7	18	uVrms
GVVR1	VRpin voltage gain1	LEVEL1="L" LEVEL2="L"	-2	0	2	dB
GVVR2	VRpin voltage gain	LEVEL1="H" LEVEL2="L"	-8	-5	-2	dB
GVVR3	VRpin voltage gain3	LEVEL1="L" LEVEL2="H"	-12	-9	-6	dB
VL	Limiter amplitude	VRpin OUT (THD=10%)	0.3	0.6	0.9	Vrms

DIGITAL SOUND CONTROLLER

TEST CURCUIT

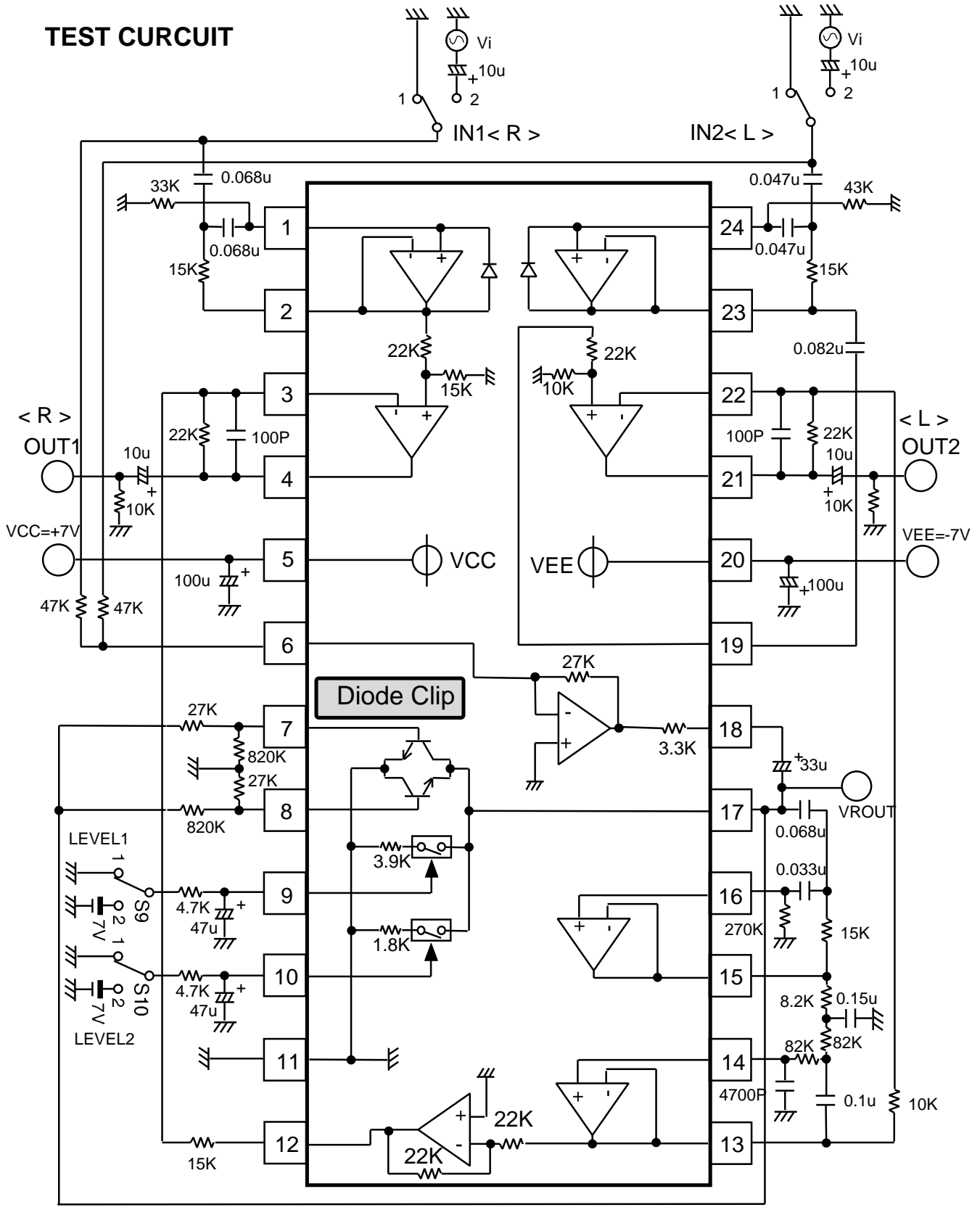

APPLICATION EXAMPLE

