

PRELIMINARY
 some parametric limits are subject to change.

M62493FP

DIGITAL SOUND CONTROLLER

SINGLE CHIP ANALOG SOUND PROCESSOR

DESCRIPTION

Home Audio, Equipment, Radio-Cassette, Recorder, TV.

FEATURES

- 6-input selector
- Input ATT (-5dB) [ON / OFF]
- 5 band graphic equalizer ; 1 band (0,±3.8,±7.6,±13dB)
4 band (0,±3,±6,±10dB)
- Electric volume 32 steps (.dB to -76dB,-)
- Treble, Bass boost [ON / OFF]
- Surround (Using external delay) [ON / OFF]
- Vocal cancel [ON / OFF]
- Multilingual record switching [ON / OFF]
- SW mode for control of DPL fields 2-lines for Rec output,
1-line for mute output.
- Input / output of adapter supporting karaoke control.
- Ability fair a single power, ±power. (The outside COM power is necessary when uses single power.)
- Supper woofer output
- Output of spectrum analyzer (L+R)

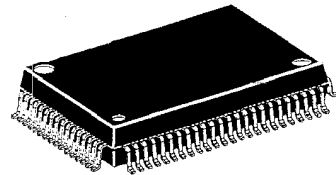

Outline 80P6N

Pitch ; 0.8 mm

Size ; 20.0 mmX14.0mmX
2.8mm

RECOMMENDED OPERATING CONDITION

Power voltage range •••±4.5V to ±7.5V [9V to 15V (When uses single power)]

SYSTEM BLOCK DIAGRAM

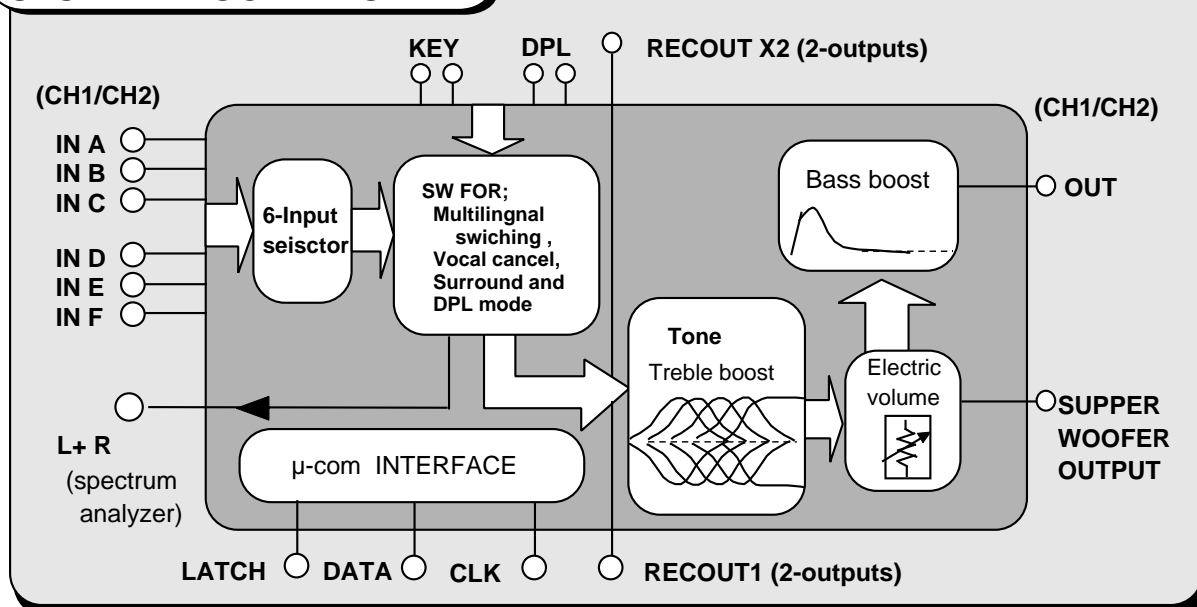

PRELIMINARY
 some parametric limits are subject to change.

M62493FP

DIGITAL SOUND CONTROLLER

PIN CONFIGURATION AND IC INTERNAL BLOCK DIAGRAM

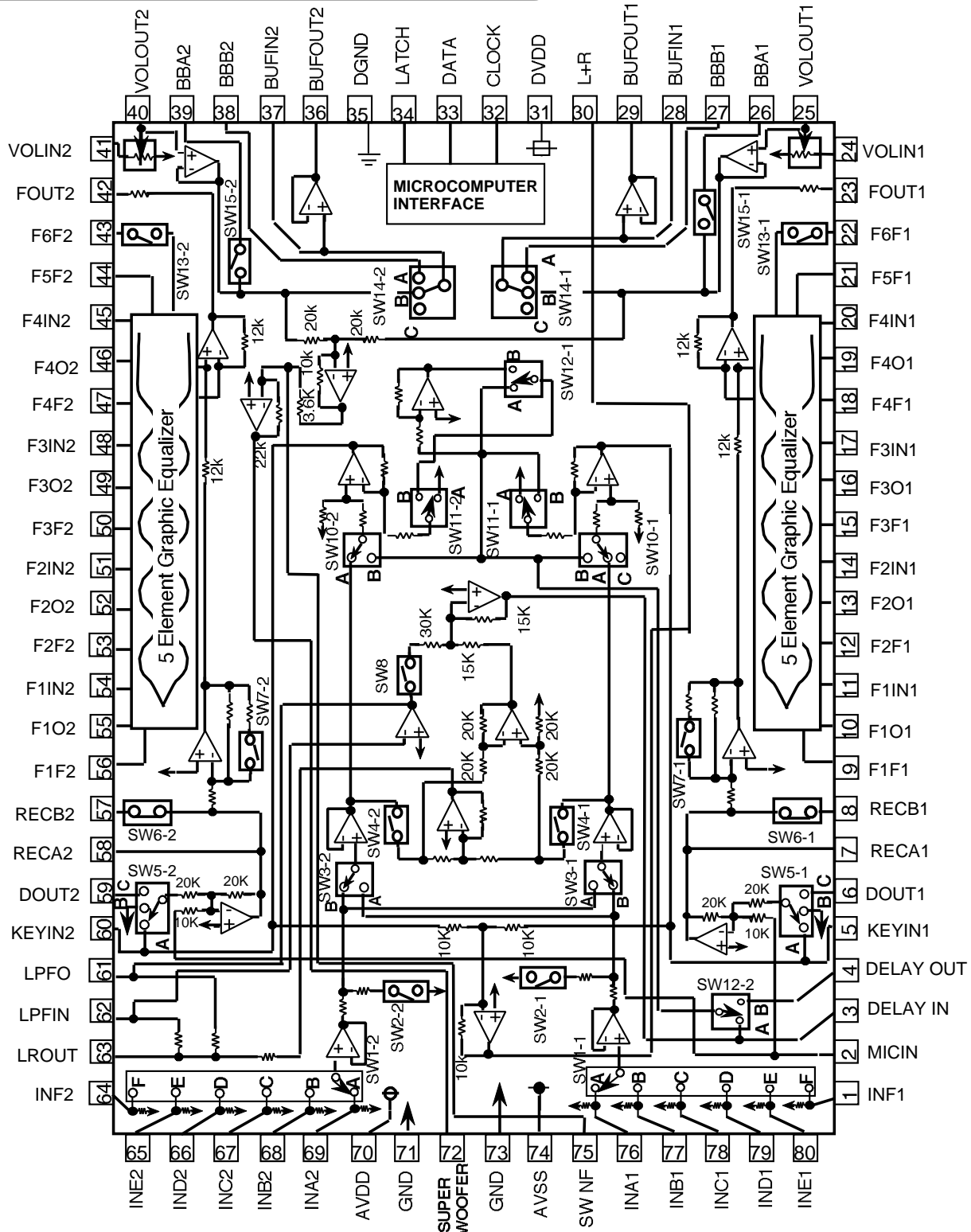

PRELIMINARY
 some parametric limits are subject to change.

M62493FP

DIGITAL SOUND CONTROLLER

ABSOLUTE MAXIMUM RATINGS

System	Parameter	Condition	Ratings	Unit
AVDD,AVSS	Analog supply voltage		± 7.8	V
DVDD	Digital supply voltage		6.0	V
Pd	Power disipation	Ta 2°C	1250	mW
K	Thermal derating	Ta > 25°C Attached PC Board*	12.5	mW / °C
Topr	Operating temperature		-20 to +55	°C
Tstg	Storage temperature		-40 to +125	°C

TYPICAL CHARACTERISTICS THERMAL DERATING

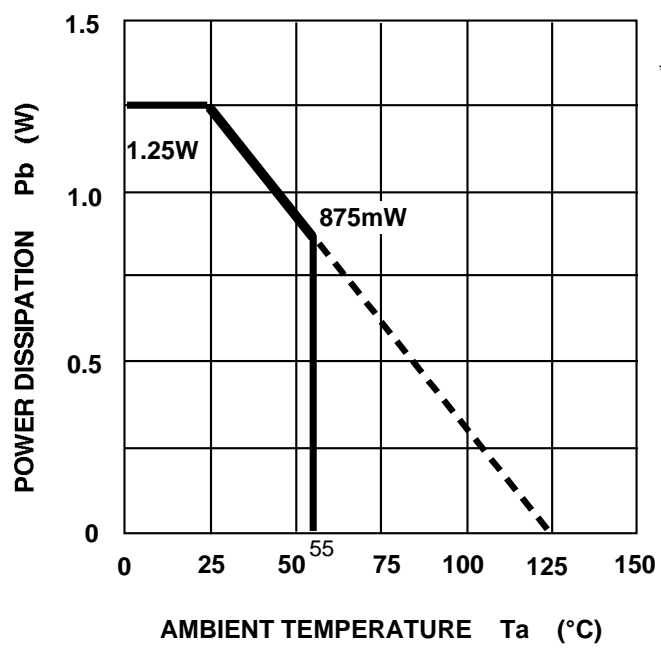

*Note ; PC Board
 PC Board Size
 140mm X140mm
 PC Board Thickness
 1.6mm
 PC Board Material
 Epoxy
 Copper Film Thickness
 18µm
 Copper Foil Size
 0.25mm X50mm

RECOMMENDED OPERATION CONDITION

(Ta = 25°C, unless otherwise noted)

Parameter	Symbol	Condition	Limits			Unit
			MIN	TYP	MAX	
Circuit current of analog positive power voltage	AVDD	Note.1	4.5	7.0	7.5	V
Circuit current of analog negative power voltage	AVSS	Note.1	-7.5	-7.0	-4.5	V
Circuit current of digital power voltage	DVDD	DVDD AVDD	4.5	5.0	5.5	V
High-level Input voltage	VIH		DVDD-0.7	—	VDD	V
Low-level Input voltage	VIL		0	—	DGND+0.7	V

Note 1 ; The sequence of the power supply is as follows.

AVDD → AVSS → DVDD

RELATIONSHIPS BETWEEN DATA AND CLOCK

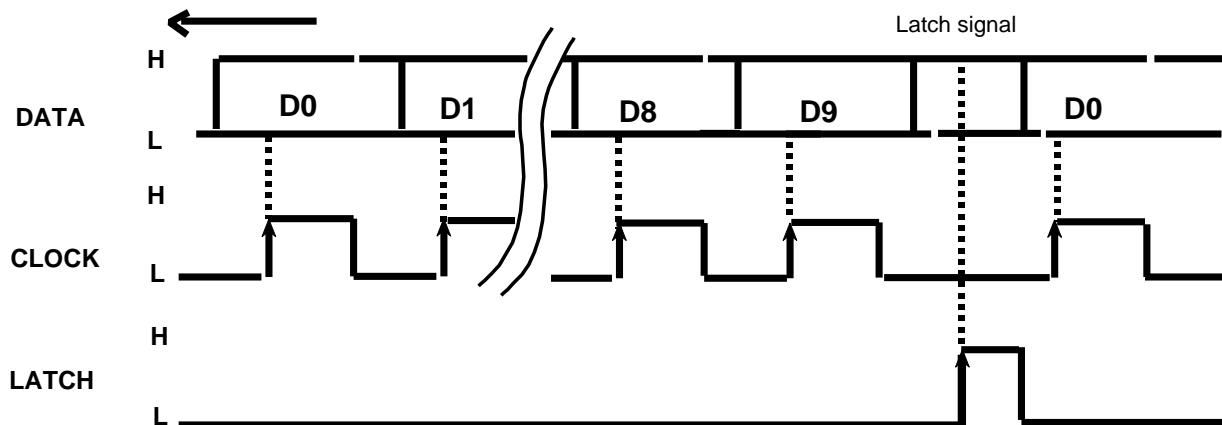

DATA reading mode ;
The rising edge of the CLOCK signal.

LATCH reading mode ;
The rising edge of the LATCH signal.

PRELIMINARY
 some parametric limits are subject to change.

M62493FP

DIGITAL SOUND CONTROLLER

CLOCK AND DATA TIMING

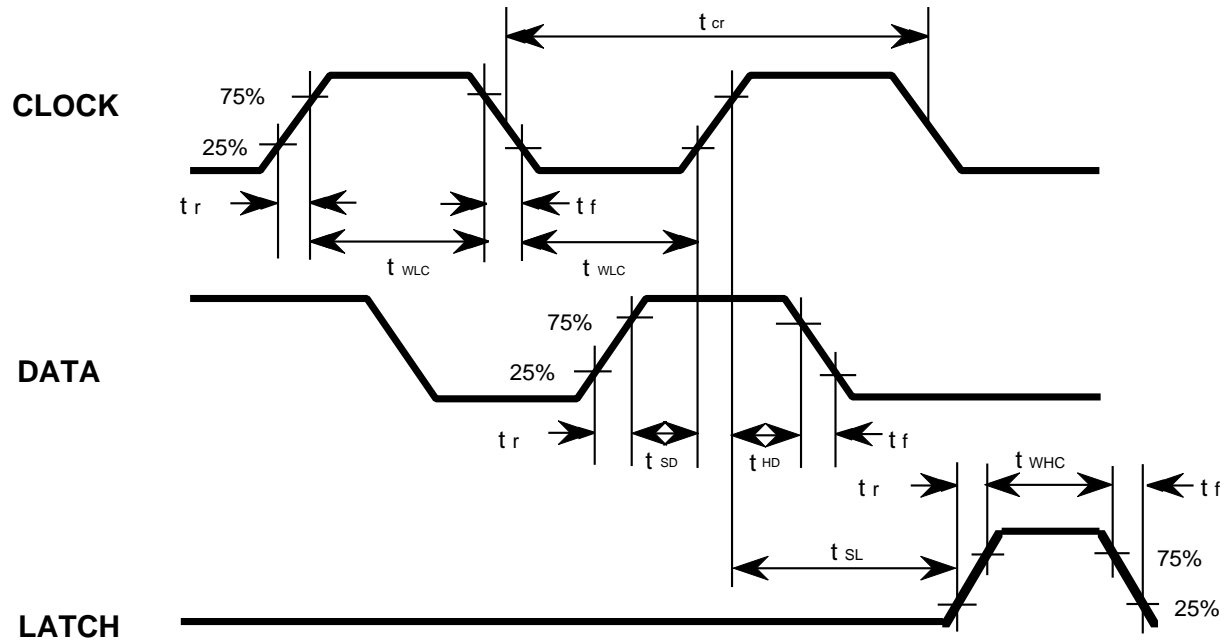

DIGITAL BLOCK TIMING REGULATION

Symbol	Parameter	Limirs			Unit
		Min	typ	Max	
t_{cr}	CLOCK cycle time	4	-	-	μsec
t_{whc}	CLOCK pulse width ("H" level)	1.6	-	-	
t_{wlc}	CLOCK pulse width ("L" level)	1.6	-	-	
t_r	CLOCK, DATA, LATCH rise time	-	-	0.4	
t_f	CLOCK, DATA, LATCH fall time	-	-	0.4	
t_{sd}	DATA setup time	0.8	-	-	
t_{hd}	DATA hold time	0.8	-	-	
t_{sl}	LATCH setup time	1	-	-	
t_{whl}	LATCH pulse width	1.6	-	-	

Downloaded from Elcodis.com electronic components distributor

DATA INPUT FORMAT

5 kinds of input format option are available by changing slot setting of D5,D6,andD7.
(When the IC is powered up, the internal setting are not fixed.)

← **Input direction**

**SLOTS OF INPUT
FORMAT SELECTION**

**FIXATION BIT
OF ADDRESS**

	DO1	D11	D21	D31	D41	D51	D6	D7	D8	D9
(1)	Input ATT 1 : -5dB 0 : 0dB	Tone ATT 1 : -6dB 0 : 0dB	For the multiplex software cf. (8) Setting code		For the function software cf. (11) Setting code		0	0	1	1
(2)	For Input Selector cf. (10) Setting code		LOW BOOST 1: ON sw15-1,2: ON sw14-1,2: A 0: OFF	HI BOOST 1: ON sw13-1,2: ON 0: OFF	SW12-2 1: B-SIDE 0: A-SIDE		0	1	1	1
(3)	For Tone Control cf. (5) Setting code		For Tone Boost / cut cf. (6) Setting code				1	0	1	1
(4-1)	For Master Volume cf. (7) Setting code						0	1	1	1
(4-2)	For REC Input Signal cf. (9) Setting code		REC OUTPUT MUTE 1: ON sw6-1,2: OFF 0: OFF	0	0	1	1	1	1	1

(5) Setting code

(Tone control)

	D03	D13	D23
Tone 1 (F1)	0	0	1
Tone 2 (F2)	0	1	0
Tone 3 (F3)	0	1	1
Tone 4 (F4)	1	0	0
Tone 5 (F5)	1	0	1

(6) Setting code

(Tone boost / cut and bass boost)

	F1	F2 to F5	D33	D43	D53
BOOST	+0 dB	+0 dB	0	0	0
	+3.8 dB	+3 dB	0	0	1
	+7.6 dB	+6 dB	0	1	0
	+13 dB	+10 dB	0	1	1
CUT	-0 dB	-0 dB	1	0	0
	-3.8 dB	-3 dB	1	0	1
	-7.6 dB	-6 dB	1	1	0
	-13 dB	-10 dB	1	1	1

Note; Do not input other data than the above.

**(7) SETTING CODE
(MASTER VOLUME)**

ATT	D04	D14	D24	D34	D44
- 0.0dB	0	0	0	0	0
- 2.0dB	1	0	0	0	0
- 4.0dB	0	1	0	0	0
- 6.0dB	1	1	0	0	0
- 8.0dB	0	0	1	0	0
- 10.0dB	1	0	1	0	0
- 12.0dB	0	1	1	0	0
- 14.0dB	1	1	1	0	0
- 16.0dB	0	0	0	1	0
- 18.0dB	1	0	0	1	0
- 20.0dB	0	1	0	1	0
- 22.0dB	1	1	0	1	0
- 24.0dB	0	0	1	1	0
- 26.0dB	1	0	1	1	0
- 28.0dB	0	1	1	1	0
- 30.0dB	1	1	1	1	0
- 32.0dB	0	0	0	0	1
- 34.0dB	1	0	0	0	1
- 36.0dB	0	1	0	0	1
- 38.0dB	1	1	0	0	1
- 40.0dB	0	0	1	0	1
- 42.0dB	1	0	1	0	1
- 44.0dB	0	1	1	0	1
- 48.0dB	1	1	1	0	1
- 52.0dB	0	0	0	1	1
- 56.0dB	1	0	0	1	1
- 60.0dB	0	1	0	1	1
- 64.0dB	1	1	0	1	1
- 68.0dB	0	0	1	1	1
- 72.0dB	1	0	1	1	1
- 76.0dB	0	1	1	1	1
-	1	1	1	1	1

(8) MULTILINGUAL RECORD CODE

	D21	D31	SW3-1	SW3-2
NORMAL	0	0	B	B
CH1 only	0	1	B	A
CH2 only	1	0	A	B
CH1 / CH2 Exchange	1	1	A	A

**(9) REC INPUT SIGNAL
CHANGE SETTING CODE**

INPUT SIGNAL	D04-2	D14-2	SW5-1 SW5-2
THROUGH	0	0	A
DPL	1	0	C
GND	0	1	B

(10) INPUT SELECTOR CODE

SELECTOR	D02	D12	D22
A	0	0	0
B	0	0	1
C	0	1	0
D	0	1	1
E	1	0	0
F	1	0	1

(11) FUNCTION CODE

INPUT SIGNAL	D41	D51	sw4-1 sw4-2	sw8	sw10-1	sw10-2	sw11-1 sw11-2	sw12-1
NORMAL	0	0	OFF	OFF	A	A	A	A
VOCAL CANCELLATION	0	1	ON	ON	B	B	A	A
SURROUND	1	0	ON	OFF	A	A	B	B

Note ; Do not input other data than the above.

ELECTRICAL CHARACTERISTICS

(Ta=25°C, AVdd=7V,AVss= -7V,DVdd=5V,f=1kHz,unless otherwise noted.
Tone control and boost are set to 0dB)

(1) POWER SUPPLY CHARACTERISTICS

Parameter	Symbol	Test conditions	Limits			Unit
			Min	typ	Max	
Circuit current (Analog+)	Aldd	Current at pin 70 with AVdd=7.0V,AVss= -7.0V No signal	—	50	58	mA
Circuit current (Analog-)	Alss	Current at pin 74 with AVdd=7.0V,AVss= -7.0V No signal	-58	-50	—	mA
Circuit current (Digital)	Didd	Current at pin 31 with DVdd=5.0V No signal	—	0.3	1.2	mA

(2) INPUT / OUTPUT CHARACTERISTICS

Parameter	Symbol	Test conditions	Limits			Unit
			Min	typ	Max	
Input resistance	Rin	76pin,69Pin	30	60	120	K
Max. input voltage	VIM	Input pin (76,64), Output pin (29,36) RL =10K , THD=1%	3.0	4.0	—	Vrms
Output pin voltage	Vodc	29pin,36pin, No signal	-0.4	0.0	0.4	V
	Vrecdc	7pin,58pin, No signal	-0.4	0.0	0.4	V
Pass gain	Gv	Vin=1Vrms,FLAT,(76,69pin)-(29, 36pin)gains.	-2.0	0	2.0	dB
Max. attenuation	ATT	Vo=1Vrms,29,36pin JIS-A filter	—	-85	-77	dB
Output noise voltage	Vono	JIS-A filter No signal,Rg=10K	—	10.0	24	μVrms
	Vrecno	FLAT condition	—	10.0	20	μVrms
Distortion factor	THD	29pin,36pin, BW=400 to 30kHz Vo=0.5Vrms, RL=10k	—	0.01	0.05	%
	THDrecA	7pin,58pin, BW=400 to 30kHz Vo=0.5Vrms, RL=30k	—	0.01	0.05	%
	THDrecB	8pin,57pin, BW=400 to 30kHz Vo=0.5Vrms, RL=51k	—	0.01	0.05	%
Crosstalk between channels	CT	Vo=0.5Vrms , RL=10K ,JIS-A 29pin - 36pin gains Rg=10K 2pin GND	—	-70	-55	dB
	CTrec	Vo=0.5Vrms , RL=30K ,JIS-A 7pin - 58pin gains Rg=10K 2pin GND	—	-70	-55	dB

(3) TONE CONTROL CHARACTERISTICS

Parameter	Symbol	Test condition	Limits			Unit	
			Min	typ	Max		
Voltage Gain (Tone control)	Gboost1	F1	3.8dB	2.3	3.8	5.3	dB
		F2 to 5	3 dB	1.5	3	4.5	
	Gboost2	F1	7.6dB	6.1	7.6	9.1	dB
		F2 to 5	6 dB	4.5	6	7.5	
	Gboost3	F1	13 dB	11.0	13	15.0	dB
		F2 to 5	10 dB	8.0	10	12.0	
	Gcut1	F1	-3.8dB	-5.3	-3.8	-2.3	dB
		F2 to 5	-3 dB	-4.5	-3	-1.5	
	Gcut2	F1	-7.6dB	-9.1	-7.6	-6.1	dB
		F2 to 5	-6 dB	-7.5	-6	-4.5	
	Gcut3	F1	-13dB	-15.0	-13	-11.0	dB
		F2 to 5	-10 dB	-12.0	-10	-8.0	
Voltage Gain (HI Boost)	Hboost	Input pin (6,59) - Output pin (23,42) gains.	6.5	8	9.5	dB	
Balance between channels	BALton	Each of boost,+10,-10dB conditions.	-1.5	0	+1.5	dB	

(4) CH1 / CH2 MIX SIGNAL

Parameter	Symbol	Test conditions	Limits			Unit
			Min	typ	Max	
Supper woofer output	Gain	GvSW Condition same as Gv RL=30k	8	10	12	dB
	Distortion factor	THDSW BW=400 to 30kHz Vo=0.5Vrms , RL=30K	—	0.03	0.15	%
	Output noise voltage	VnoSW Condition same as Vono No signal, JIS-A filter	—	70	170	μVrms
L+R Output voltage	GvLR	Condition same as Gv RL=51k	-2	0	2	dB

PRELIMINARY
some parametric limits are subject to change.

M62493FP

DIGITAL SOUND CONTROLLER

MASTER VOLUME CIRCUIT

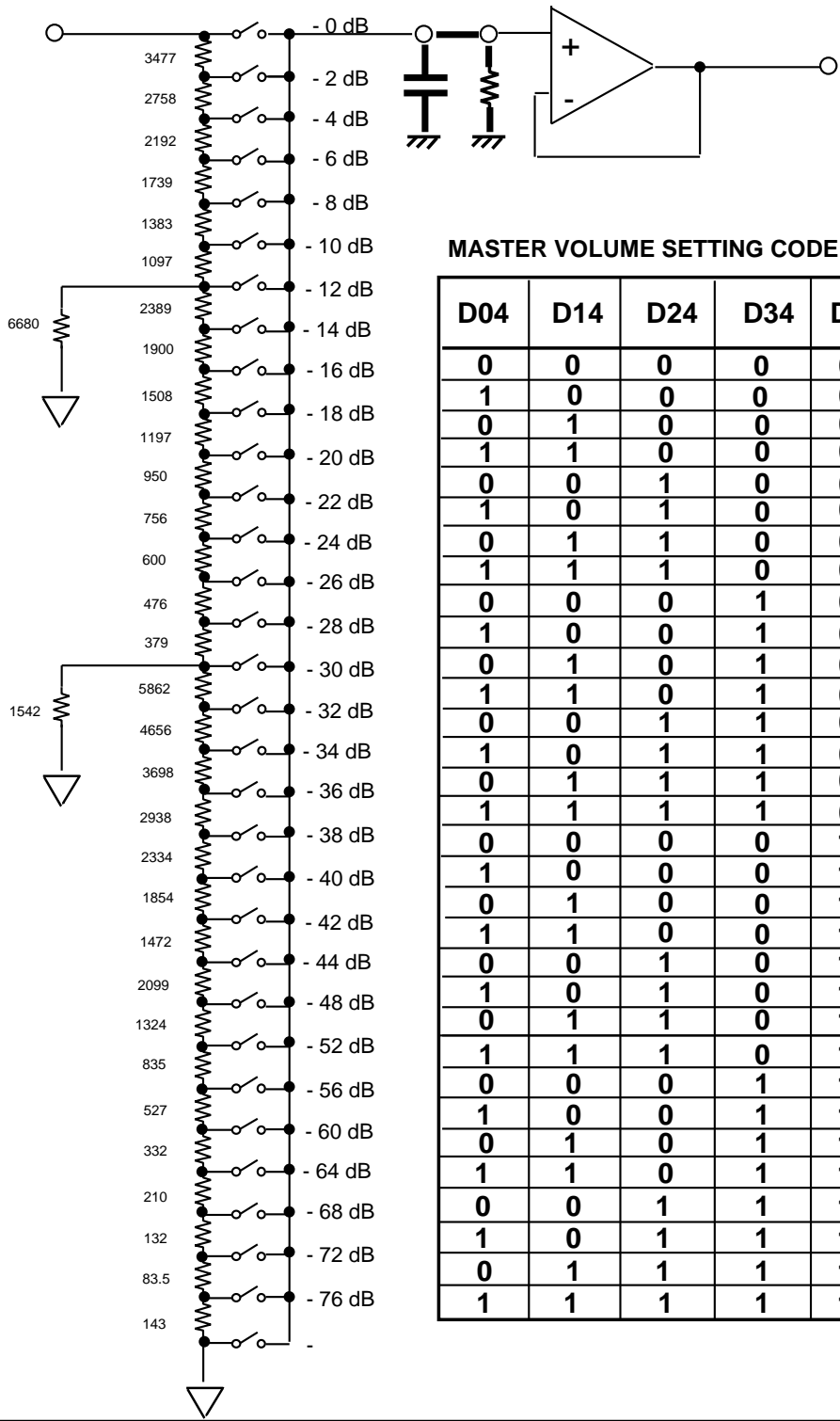

MASTER VOLUME SETTING CODE

D04	D14	D24	D34	D44	ATT
0	0	0	0	0	- 0.0dB
1	0	0	0	0	- 2.0dB
0	1	0	0	0	- 4.0dB
1	1	0	0	0	- 6.0dB
0	0	1	0	0	- 8.0dB
1	0	1	0	0	- 10.0dB
0	1	1	0	0	- 12.0dB
1	1	1	0	0	- 14.0dB
0	0	0	1	0	- 16.0dB
1	0	0	1	0	- 18.0dB
0	1	0	1	0	- 20.0dB
1	1	0	1	0	- 22.0dB
0	0	1	1	0	- 24.0dB
1	0	1	1	0	- 26.0dB
0	1	1	1	0	- 28.0dB
1	1	1	1	0	- 30.0dB
0	0	0	0	1	- 32.0dB
1	0	0	0	1	- 34.0dB
0	1	0	0	1	- 36.0dB
1	1	0	0	1	- 38.0dB
0	0	1	0	1	- 40.0dB
1	0	1	0	1	- 42.0dB
0	1	1	0	1	- 44.0dB
1	1	1	0	1	- 48.0dB
0	0	0	1	1	- 52.0dB
1	0	0	1	1	- 56.0dB
0	1	0	1	1	- 60.0dB
1	1	0	1	1	- 64.0dB
0	0	1	1	1	- 68.0dB
1	0	1	1	1	- 72.0dB
0	1	1	1	1	- 76.0dB
1	1	1	1	1	-

Downloaded from Elcodis.com electronic components distributor

PRELIMINARY

Notice ; This is not a final specification.
some parametric limits are subject to change.

M62493FP

FUNCTION DESCRIPTION

(1) TONE CONTROLLER EQUIVALENT CIRCUIT

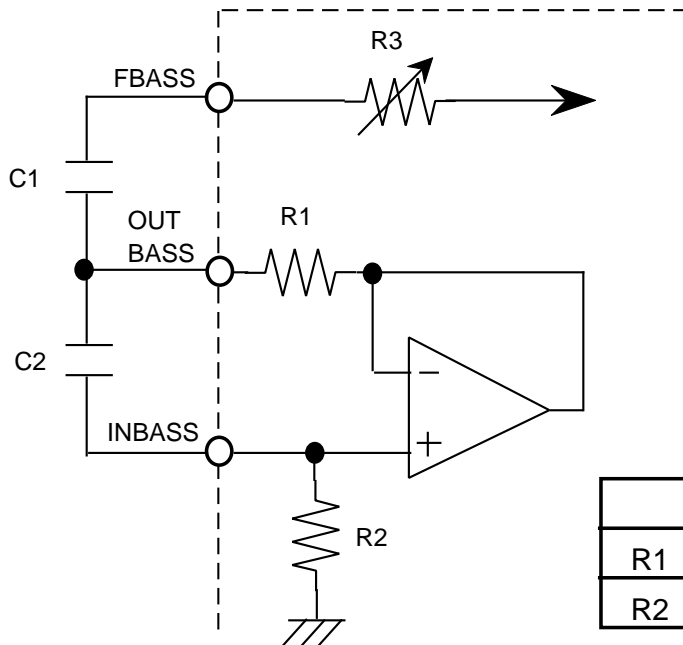

Center frequency

$$f_0 = 1 / 2 \sqrt{C1 \cdot C2 \cdot R1 \cdot R2} \text{ [Hz]}$$

$$Q = \sqrt{C2 (R1 \cdot R2) / C1 (R1 + R3)^2}$$

	F1	F2	F3	F4	F5
R1	1.49k	1.49k	1.49k	1.49k	—
R2	306k	306k	306k	306k	—

Fig.1 ; The equivalent circuit of tone controller.

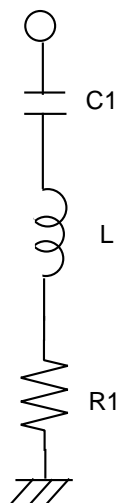

Fig.2 is equivalent to Fig.1.
To convert component constants,
the equation below is used.

$$L = C2 \cdot R1 \cdot R2$$

Fig.2 ; The equivalent circuit using L

PRELIMINARY

Notice ; This is not a final specification.
some parametric limits are subject to change.

MITSUBISHI SOUND PROCESSORS

M62493FP

DIGITAL SOUND CONTROLLER

(2) VOCAL CUT L.P.F EQUIVALENT CIRCUIT

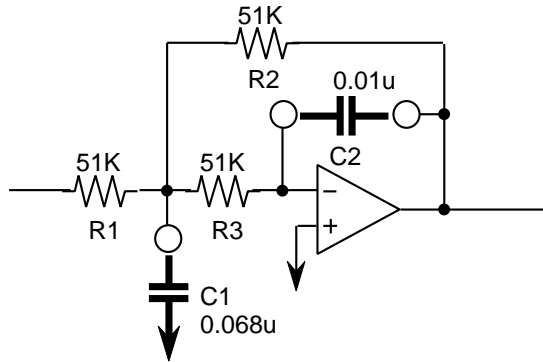

$$T(s) = \frac{Aw_0^2}{s^2 + \frac{w_0}{Q}s + w_0^2}$$

$$Q = \frac{\sqrt{R1 \cdot R2 \cdot C1 \cdot C2}}{R2 \cdot C2 + R1 \cdot C2 + \frac{R1 \cdot R2}{R3} C2}$$

$$\left\{ \begin{aligned} A &= -\frac{R1}{R2} \\ \frac{w_0}{Q} &= \frac{1}{C1} \left(\frac{1}{R1} + \frac{1}{R2} + \frac{1}{R3} \right) \\ w_0 &= \frac{1}{R1 \cdot R2 \cdot C1 \cdot C2} \end{aligned} \right.$$

At the time of ; R1=R2=R3 ,
Become ; A = -1

$$f_c = \frac{1}{2 \sqrt{R1 \cdot R2 \cdot C1 \cdot C2}}$$

$$Q = \frac{1}{3} \sqrt{\frac{C1}{C2}} \quad (\text{Using } Q < Z)$$

At the time of ; R1=R2=R3=51k ,
C1=0.068uF, C2=0.01uF

Become ; f_c ÷ 120Hz
Q ÷ 0.87

Pay attention to In-Output turning over, because using turnig over mode.

PRELIMINARY

Notice ; This is not a final specification.
some parametric limits are subject to change.

M62493FP

DIGITAL SOUND CONTROLLER

(3) BASS BOOST EQUIVALENT CIRCUIT

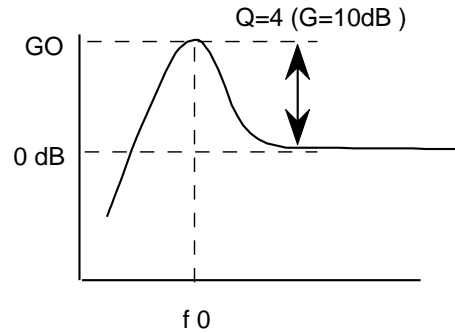
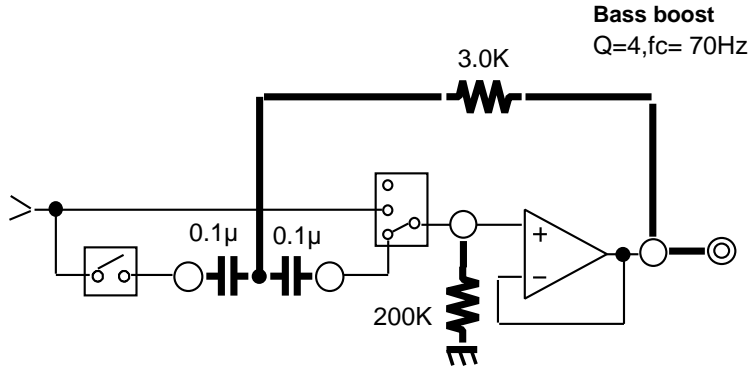

Original return type 2 dimensions HPF circuit of Bass boost.

Amplitude characteristic of HPF (Reference)

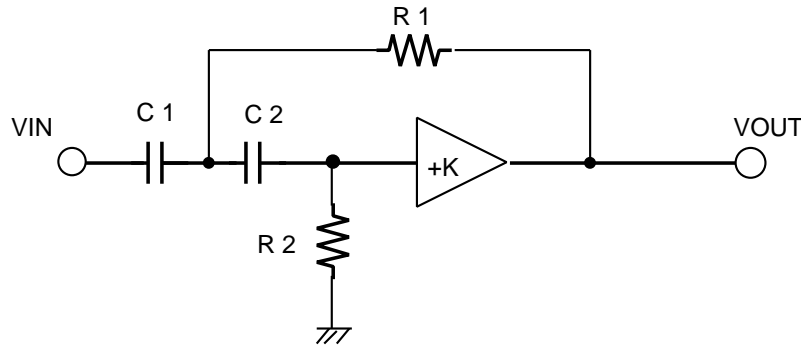

Q	GO
1	0 to 1 dB
2	6 dB
4	10 dB
5	13 dB
10	20 dB

Communication function is ;

$$\frac{V_{OUT}}{V_{IN}} = \frac{Ks^2}{s^2 + s \left[\frac{1}{R_2C_1} + \frac{1}{R_2C_2} + (1-K) \frac{1}{R_1C_1} \right] + \frac{1}{R_1R_2C_1C_2}}$$

$$\omega_0^2 = \frac{1}{R_1R_2C_1C_2}$$

$$Q = \frac{1}{\sqrt{\frac{R_1C_1}{R_2C_2}} + \sqrt{\frac{R_1C_2}{R_2C_1}} + (1-K)\sqrt{\frac{R_2C_2}{R_1C_1}}}$$

Bass boost consists of original return type 2 dimensions HPF circuit of upper figure.
To the following showing an example of method of design calculation of Bass boost.

At the time of ;
 $C_1 = C_2 = C_f, K = +1$

The upper expression becomes ;
 $R_f = 1 / (\omega_0 C_f) \dots (1)$

$R_1 = R_f / 2Q \dots (2)$

$R_2 = 2Q R_f \dots (3)$

When cut off frequency is 70Hz ,
 $\omega_0 = 2\pi \times 70\text{Hz}, Q=4$, condition.

At the time of ; $C_1=C_2=C_f=0.1\mu\text{F}$
 From ; (1),(2),(3)
 Become ; $R_f=22.7\text{K}$
 $R_1 = 2.84\text{K}$
 $R_2 = 182\text{K}$

R_1, R_2 is about 3.0K ,200K

PRELIMINARY

Notice ; This is not a final specification.
some parametric limits are subject to change.

MITSUBISHI SOUND PROCESSORS

M62493FP

DIGITAL SOUND CONTROLLER

(4) VOCAL CANCELLATION EQUIVALENT CIRCUIT

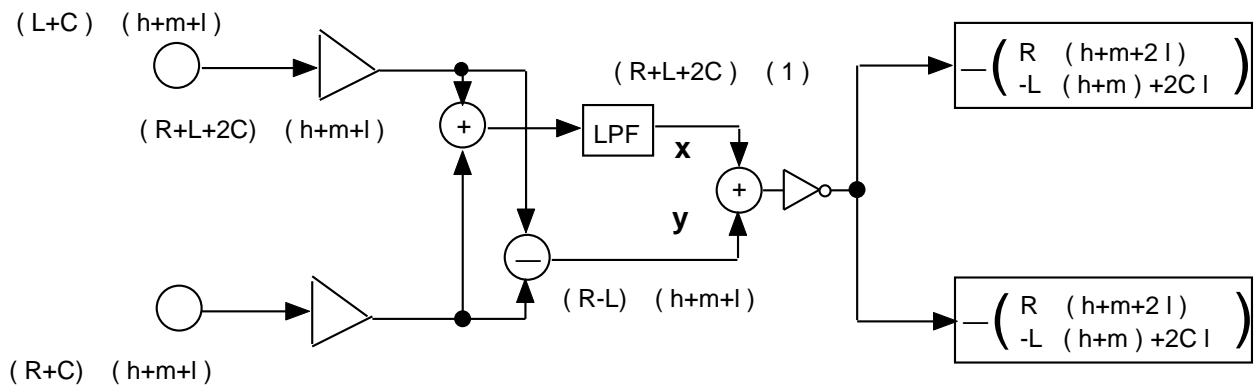

(5) SURROUND EQUIVALENT CIRCUIT

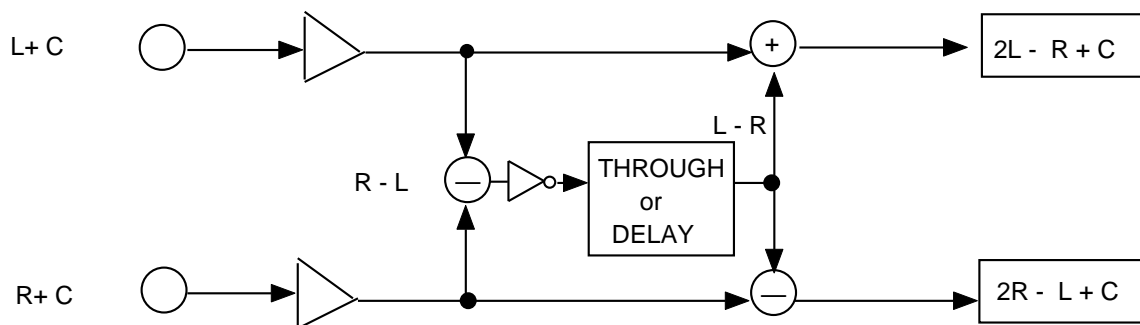

PRELIMINARY

Notice ; This is not a final specification.
some parametric limits are subject to change.

MITSUBISHI SOUND PROCESSORS

M62493FP

DIGITAL SOUND CONTROLLER

SIGNAL COMMUNICATION BLOCK CIRCUIT (NO.1)

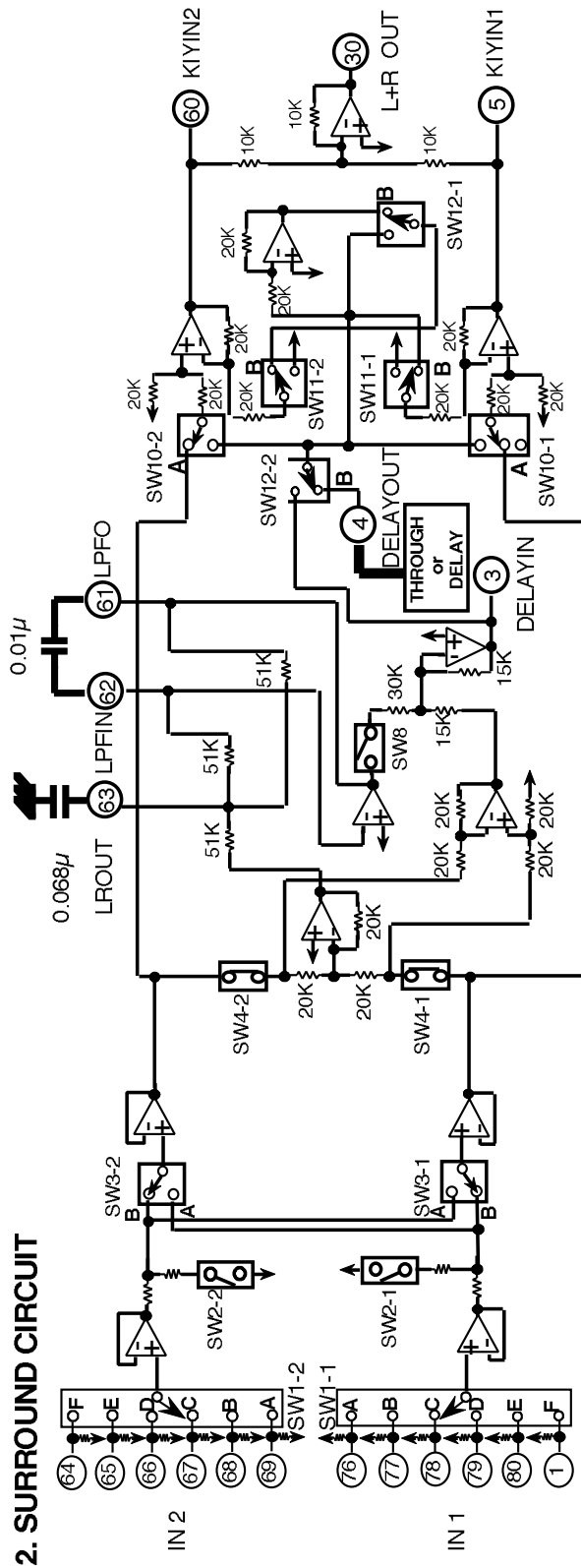
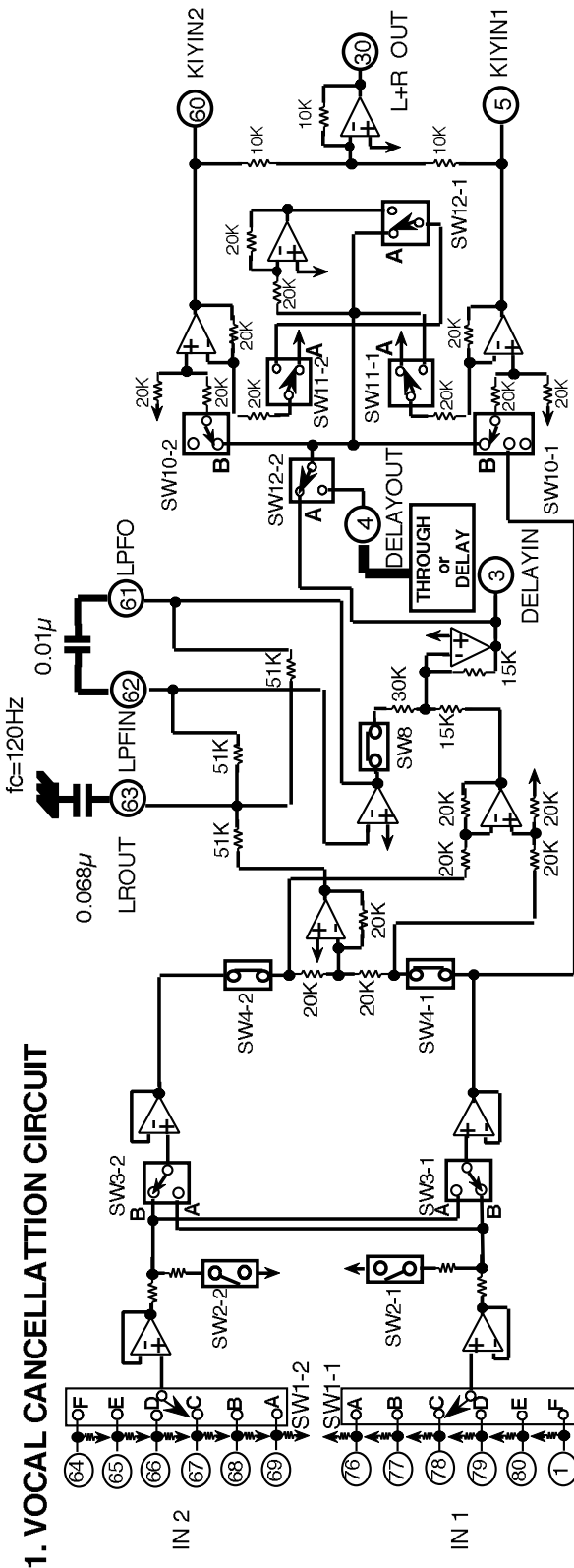

PRELIMINARY

Notice ; This is not a final specification.
some parametric limits are subject to change.

MITSUBISHI SOUND PROCESSORS

M62493FP

DIGITAL SOUND CONTROLLER

SIGNAL COMMUNICATION BLOCK CIRCUIT (No.2)

3. TONE CURCUIT (CH1)

Each of frequency +10dB to -10dB, change

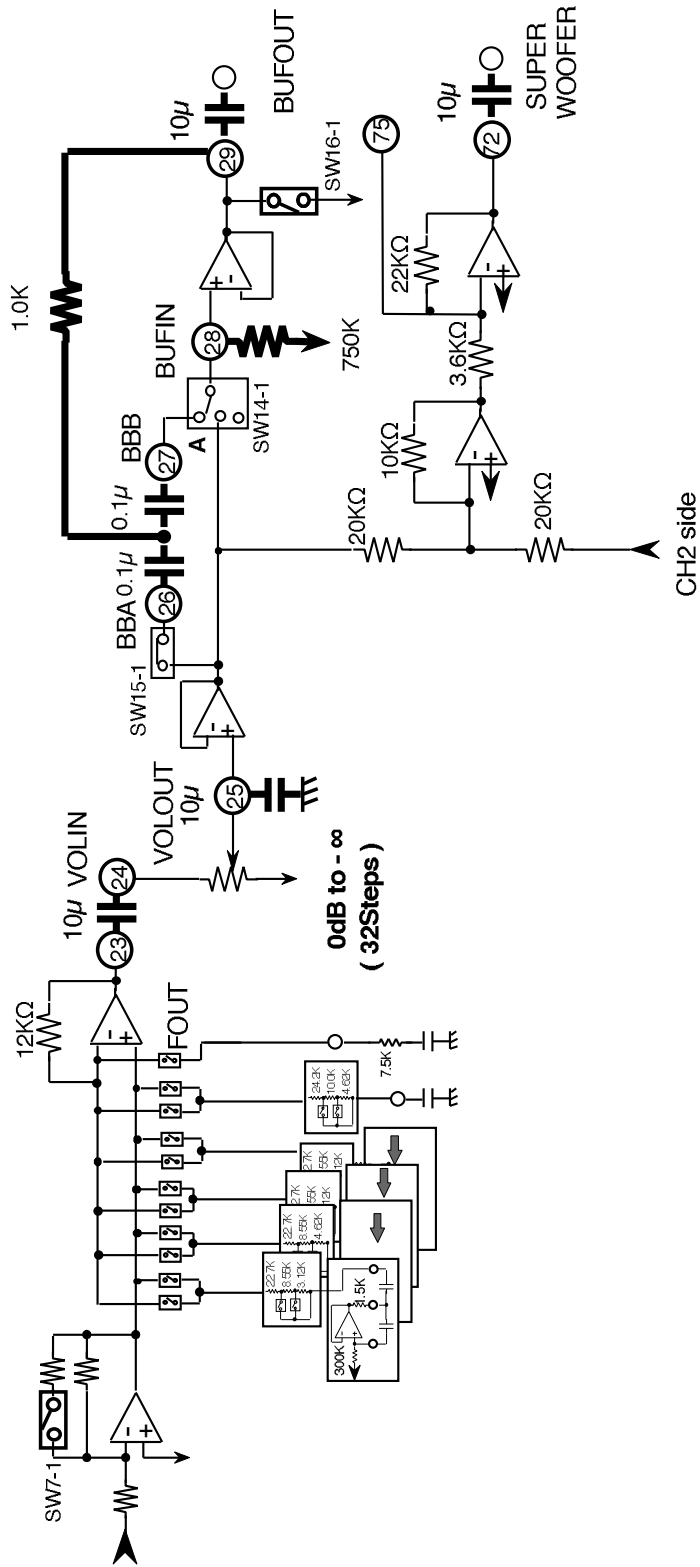

PRELIMINARY

Notice ; This is not a final specification.
some parametric limits are subject to change.

MITSUBISHI SOUND PROCESSORS

M62493FP

DIGITAL SOUND CONTROLLER

REC INPUT CHANGE CIRCUIT

(1) THROUGH MODE

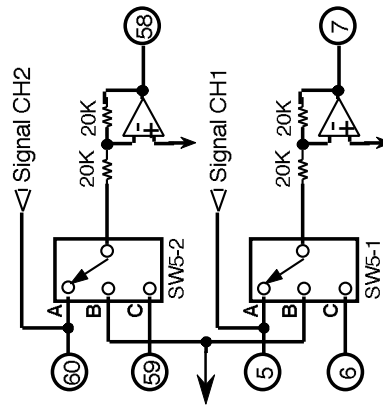

(2) DPL MODE

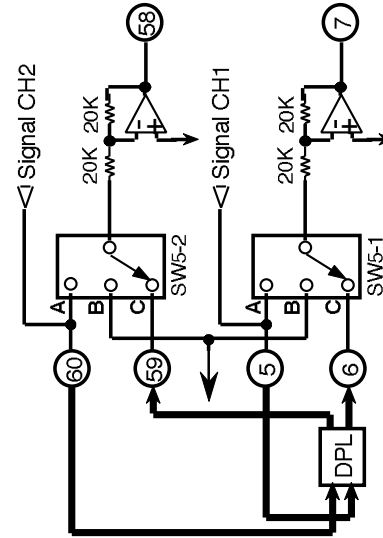

PRELIMINARY

Notice ; This is not a final specification.
some parametric limits are subject to change.

MITSUBISHI SOUND PROCESSORS

M62493FP

DIGITAL SOUND CONTROLLER

