

July 25, 2000

TEL:805-498-2111 FAX:805-498-3804 WEB:http://www.semtech.com

DESCRIPTION

The SC1146 is the latest, high performance, multi-phase (PWM) controller designed for high power microprocessors requiring ultra fast transient response. The SC1146 is programmable for the voltage range required by the latest Microprocessors. Utilizing a novel and unique design, the controller distributes the output load across (up to) four converter channels by digitally phase shifting the PWM outputs. This approach greatly reduces the stress and heat on the output stage components while lowering input ripple current by as much as 80%. Accurate current sharing among the four phases is achieved by precision design techniques and trimming of critical elements.

The high speed transconductance error amplifier is externally initialized using a soft-start capacitor allowing the controller to "wake-up" without overshoot, thus protecting the low voltage microprocessor loads. The output drive voltage to the power MOSFETs is programmable to minimize switching losses in the drive circuitry.

The output voltage is digitally programmable by means of a 5 bit DAC (new codes). A single resistor programs the master clock frequency (8MHz max) or the clock can be supplied by an external source where exact frequency control is desired. The number of operating phases is programmed independently of the external clock. The parts features under-voltage lock-out with hysteresis and over-current protection.

FEATURES

- Allows use of small surface mount components
- Ultra fast transient recovery time
- Dramatic reduction of input ripple current and output ripple voltage
- **5-bit programmable DAC for the latest, lower output voltage Microprocessors**
- Wide, High frequency operating range
- Selectable 2, 3, 4 phase operation
- **+5 Volt only operation eliminates the need for +12V supply**
- Precision load current sharing, 1% PWM match
- Selectable internal or external clock
- Soft start/UVLO/Over current protection

APPLICATIONS

- High end servers and workstations
- High current/Ultra-fast transient microprocessors

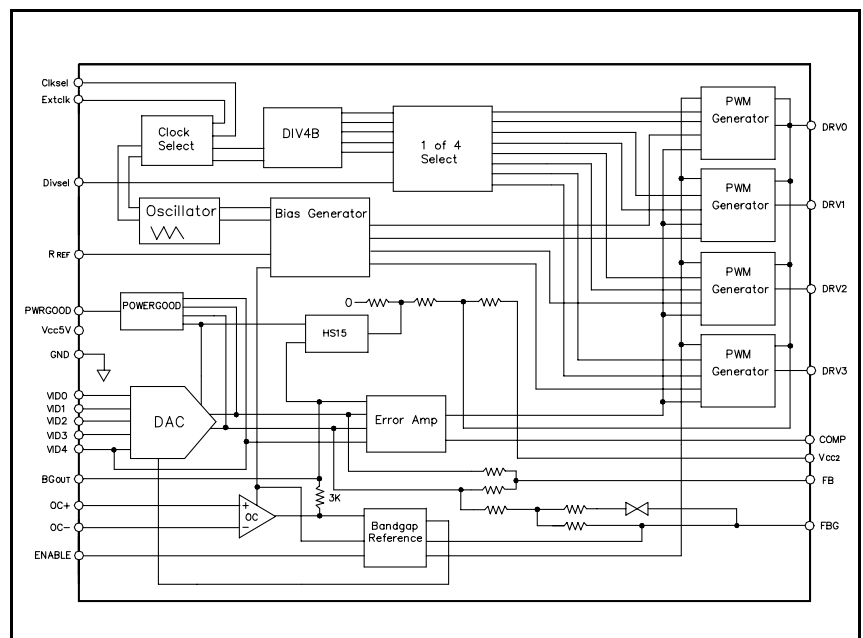
ORDERING INFORMATION

DEVICE ⁽¹⁾	PACKAGE	TEMP. (T _J)
SC1146CSW.TR	SO-24	0 - 85°C

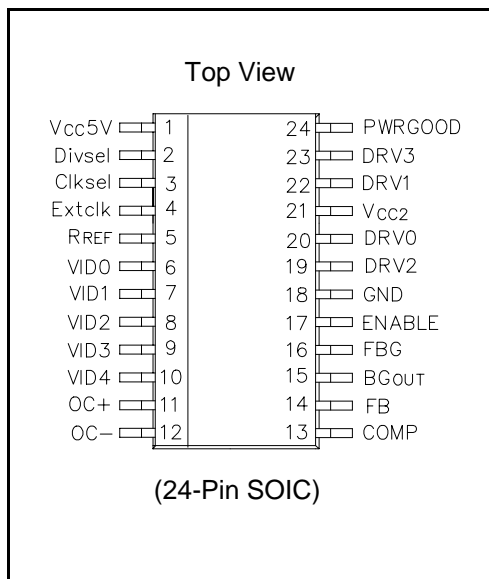
Note:

(1) Only available in tape and reel packaging. A reel contains 1000 devices.

BLOCK DIAGRAM



PIN CONFIGURATION



July 25, 2000

ABSOLUTE MAXIMUM RATINGS

Parameter	Symbol	Limits	Units
V _{CC5V} to GND	V _{CC5V}	-0.3 to + 12	V
FBG to GND	FBG	± 1	V
V _{CC2} to GND	V _{CC2}	-0.3 to +20	V
Operating Temperature Range	T _A	0 to +70	°C
Junction Temperature Range	T _J	0 to +125	°C
Storage Temperature Range	T _{STG}	-55 to +150	°C
Thermal Resistance Junction to Case	θ _{JC}	25	°C/W
Thermal Resistance Junction to Ambient	θ _{JA}	80	°C/W
Lead Temperature (Soldering) 10 sec	T _{LEAD}	300	°C

ELECTRICAL CHARACTERISTICS

 Unless otherwise noted: T_A = 25°C, V_{CC5V} = 5V, V_{CC2} = 5V, 4-Phase operation.

PARAMETER	SYMBOL	CONDITIONS	MIN	TYP	MAX	UNITS
Supply Voltage Range	V _{CC2}		3.9	5.0	15.0	V
UVLO Range	V _{CC5V}		3.9	5.0	6.0	V
UVLO Hysteresis	V _{CC5V}			TBD		mV
Supply Voltage Range	V _{CC5V}		4.5	5.0	5.5	V
Supply Current	V _{CC2}	DRV Outputs open		10		mA
Supply Current	V _{CC5V}	V _{OUT} = 2.00V, I _O = 0			40	mA
Reference Current Pin Voltage	V _{REF}	I _{ref} = 250µA		2.05		V
VID0-4 Clock Select & Divide	V _{INL}	Logic Low			0.8	V
Select Logic Threshold	V _{INH}	Logic High	2			V
VID0-4 Clock Select & Divide	I _{INL}	Vid0-4 = 0V			-20	µA
Select Input Bias Current	I _{INH}	Vid0-4 = 4.5V			+50	µA
Enable Pin	V _{INL}				.8	V
	V _{INH}		2			V
Maximum Duty Cycle	D _{MAX}	FB = 0V		75		%
DRV0-3 Output Voltage	V _{OL}	I _{sink} = 1mA			.3	V
	V _{OH}	I _{source} = 1mA, PWRGOOD = V _{CC5V}	V _{CC2} -1			V
DRV0-3 Source Current	I _{SRC}	V _{OUT} = 2.00V		40		mA
DRV0-3 Sink Current	I _{SNK}	V _{OUT} = 2.00V		20		mA

July 25, 2000

ELECTRICAL CHARACTERISTICS (Cont.)

 Unless otherwise noted: $T_A = 25^\circ\text{C}$, $V_{CC5V} = 5V$, $V_{CC2} = 5V$, 4-Phase operation.

PARAMETER	SYMBOL	CONDITIONS	MIN	TYP	MAX	UNITS
Bgout Voltage	V_{Bgout}	$V_{id} = 00000$	TBD	1.30	TBD	V
Bgout Impedance	R_{O_Bg}			3		$K\Omega$
External Clock Freq. Range	F_{ext_CK}		.80	8.0	8.5	MHz
Oscillator Frequency	F_{OSC}	$I_{ref} = 250\mu\text{A}$	7.6	8.0	8.4	MHz
Internal Clock Freq. Range	F_{int_CK}		.80	8.0	8.5	MHz
Match DRV0-3	Δ_D	Duty cycle (Avg) = 50%	-1		+1	%
PWM Off Time	T_{off}				25	%
Overcurrent Comparator, Comparator, Common Mode Range	OCC_CMR		3		15	V
OC+I/P bias Current	I_{B_OC+}	$V_{in} = 5V$	+75		+250	μA
OC-I/P bias Current	I_{B_OC-}	$V_{in} = 5V$	+75		+250	μA
Input Offset Voltage	V_{OS_OCC}	$V_{in} = 5V$		10		mV
Feedback Input Impedance	R_{i_FB}	$V_o = 2.00V$		12		$K\Omega$
Duty Cycle Range	D		0		75	%
CONVERTER SPECIFICATIONS, Reference Application Circuit						
Output Accuracy Over Set Range	V_{OUT}	VID 0-4 = 0000-1111 $V_{CC5V} = 5.0V$	-1		+1	%
Load Regulation	$\frac{\Delta V_{OUT}}{\Delta I_O}$	$V_o = 2.000V$ $I_o = 3A - 20A$.025	.05	%/A
Line Regulation	$\frac{\Delta V_{OUT}}{\Delta V_{IN}}$	$V_{CC5V} = 5V$, $V_o = 2.000V$ $V_{IN} = 4-6V$, (V_{IN} separated from V_{CC5V}) $I_o = 5A$, Clk = external		.15		%/V
POWER GOOD SIGNAL						
Off Leakage Current	$I_{leakage_Off}$	PWRGOOD = Logic High			2	μA
Power Good Max Sink Current	I_{Sink_Max}	PWRGOOD <= .8V			2	mA
Power Good Threshold	$P_{wrgood_T_lo}$	$V_{out} = 1.300V - 1.950V$		± 100		mV
Voltage Tolerance	$P_{wrgood_T_Hi}$	$V_{out} = 2.000V - 3.500V$		± 150		mV

Note:

(1) This device is ESD sensitive. Use of standard ESD handling precautions is required.

July 25, 2000

PIN DESCRIPTION

Pin #	Pin Name	Pin Function
1	V _{CC5V}	Supply voltage input (5V nominal)
2	Divsel	Connect to Gnd for four phase operation and to logic High for three Phase operation.
3	Clkssel	Clock Select: Logic High selects internal clock. Logic Low selects external clock.
4	Extclk	External Clock Input. The output frequency is determined by (Clock Input Freq.)/4. Output freq.= (Clock Input)/4. Pull up to Vcc5v to select internal clock.
5	R _{REF}	Connects to external reference resistor. Sets the operating frequency of the internal clock and the ramp time for the PWM. Reference voltage at this pin is 2.05V. Trimmed to set 250µA at 8MHz.
6	VID0 ⁽¹⁾	Programming Input (LSB)
7	VID1 ⁽¹⁾	Programming Input
8	VID2 ⁽¹⁾	Programming Input
9	VID3 ⁽¹⁾	Programming Input
10	VID4 ⁽¹⁾	Programming Input (MSB)
11	OC+	Over current comparator. Non-Inverting input.
12	OC-	Over current comparator. Inverting input.
13	COMP	Compensation Pin. Compensation is achieved by connecting a capacitor in series with a resistor between this pin and FBG. A 300K ohm resistor must also be directly connected between this pin and FBG.
14	FB	Feedback input connected to supply output.
15	BG _{OUT}	Bandgap Reference Output. Output resistance = 3Kohm. Must be bypassed with 4.7nF-100nF capacitor to FBG. This capacitor programs the soft start time.
16	FBG	Feedback Ground. This pin must be connected to return side of output caps. This pin is not internally connected to GND.
17	ENABLE	Connects to 5V to ENABLE. Connect to GND to disable entire device.
18	GND	Ground Pin
19	DRV2	Phase 2 output, output voltage range ~.3V - V _{CC2} - 1V.
20	DRV0	Phase 0 output, output voltage range ~.3V - V _{CC2} - 1V.
21	VCC2	Supply voltage for the DRV0-3, may be connected to +5V or +12V supply. There is no Undervoltage Lockout on this pin.
22	DRV1	Phase 1 output, output voltage range ~.3V - V _{CC2} - 1V.
23	DRV3	Phase 3 output, output voltage range ~.3V - V _{CC2} - 1V.
24	PWRGOOD	Power good should be pulled-up to 5V supply via a 3K - 10K resistor.

NOTE: (1) All logic inputs and outputs are open collector TTL compatible.

July 25, 2000

OUTPUT VOLTAGE					V_{CCORE}
Unless specified: 0 = GND; 1 = High (or Floating).					
$T_A = 25^\circ\text{C}$, $V_{CCSV} = 5\text{V}$, $V_{CC2} = 5\text{V}$, 4-Phase operation.					
VID4	VID3	VID2	VID1	VID0	(VDC)
1	1	1	1	1	Output Off
1	1	1	1	0	1.1
1	1	1	0	1	1.125
1	1	1	0	0	1.15
1	1	0	1	1	1.175
1	1	0	1	0	1.2
1	1	0	0	1	1.225
1	1	0	0	0	1.250
1	0	1	1	1	1.275
1	0	1	1	0	1.3
1	0	1	0	1	1.325
1	0	1	0	0	1.35
1	0	0	1	1	1.375
1	0	0	1	0	1.4
1	0	0	0	1	1.425
1	0	0	0	0	1.45
0	1	1	1	1	1.475
0	1	1	1	0	1.5
0	1	1	0	1	1.525
0	1	1	0	0	1.55
0	1	0	1	1	1.575
0	1	0	1	0	1.6
0	1	0	0	1	1.625
0	1	0	0	0	1.65
0	0	1	1	1	1.675
0	0	1	1	0	1.7
0	0	1	0	1	1.725
0	0	1	0	0	1.75
0	0	0	1	1	1.775
0	0	0	1	0	1.8
0	0	0	0	1	1.825
0	0	0	0	0	1.85



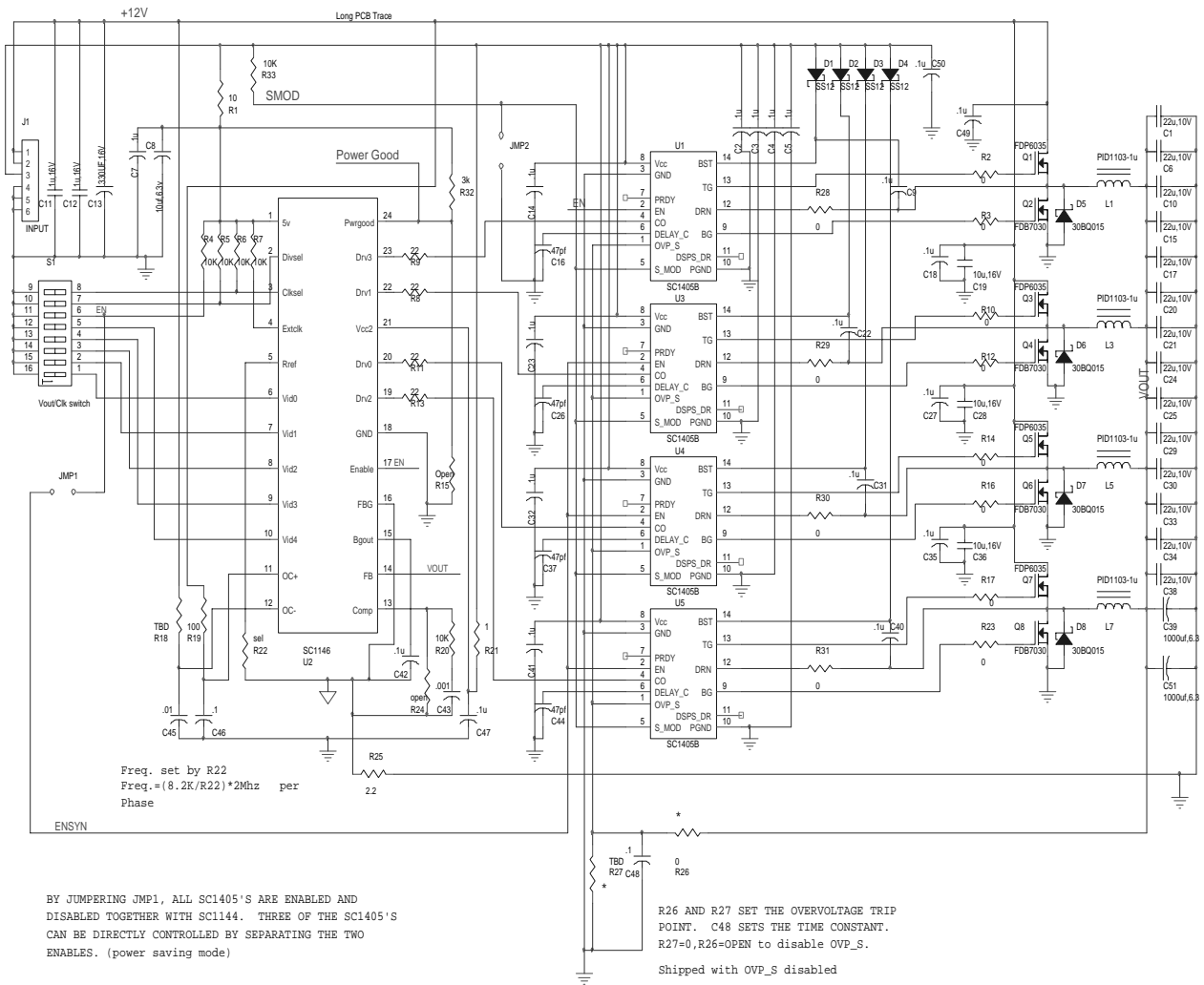
SEMTECH
Today's Results. Tomorrow's Vision

**VRM9.0 PROGRAMMABLE, MULTI-PHASE,
HIGH PERFORMANCE PWM CONTROLLER**

SC1146

July 25, 2000

EVALUATION BOARD SCHEMATIC



July 25, 2000

BILL OF MATERIAL

Item	Qty	Reference	Value	Manufacturer
1	9	C2,C4,C11,C19,C20,C28,C29,C37,C39	1u,10V	X7R, AVX (818)883-7606
2	1	C3	10uF, 6.3V	Al. Elec.,Murata
3	9	C5,C12,C14,C17,C18,C21,C22,C26,C27	22u, 10V	Murata (512)250-5082 PN #GRM235Y5V226Z010
4	5	C6,C7,C15,C24,C32	1uF, 16V	Murata,Al. Elec.
5	1	C8	330uF, 16V	Nichicon
6	3	C16,C25,C33	10u, 16V	Murata
7	1	C40	.01u	Murata
8	1	C42	.022	any
9	2	C45,C49	.01	Murata,X7R
10	1	C46	.001	Murata
11	4	C50,C51,C52,C53	1nF	any
12	1	C54	1000uF	Murata,Al. Elec.
13	8	D1,D2,D3,D4, D5,D7,D9,D11	SS12(1A) SS32 (3A)	General Instruments General Instruments
14	1	J1	INPUT	
15	4	L1,L2,L3,L4	.6uh,12A	Falco (305)662-7276 PN #T02508
16	4	Q1,Q4,Q7,Q10	IR7811	Int. Rectifier
17	4	Q3,Q6,Q9,Q12	IR3101D2 (Alter.)FDB7030BL	Int. Rectifier Fairchild Semiconductors
18	1	R1	10	Dale,any
19	9	R2,R10,C13,R14,R17,C23,R33,C34,C43	0	any
20	4	R4,R12,R16,R23	1.5 (or zero)	any
21	4	R5,R6,R7,R38	10K	any
22	4	R8,R9,R11,R13	22	any
23	1	R18	SEL	any
23	1	R19	100	any
24	1	R20	2.2k	any
25	1	R22	15k	any
26	1	R24	300k	any
27	5	R25,R40,R41,R42,R43	2.2	any
28	1	R26	open	any
29	4	R27,R28,R29,R30	51, 1/4W, 1206, 10K	Dale
30	6	R31,R32,R34,R35,R36,R37	TBD(used at light load, contact factory)	any
31	1	S1	Vout/Clk switch C&K	(800)cal-swch
32	4	U1,U3,U4,U5	SC1405B/SC1405TS	Semtech (805)498-2111
33	1	U2	SC1146CSW	Semtech (805)498-2111
34	1	U6	LM358	any

Unless otherwise noted, all resistors are 1/10W, 5%, 0805 and all capacitors are 20%, 50v, 0805.

July 25, 2000

THEORY OF OPERATION

FUNCTIONAL DESCRIPTION

The SC1146 is a programmable, high performance, multi-phase controller designed for the most demanding DC/DC converter applications in which transient response, space, input ripple current and component form factor and cost are paramount. The SC1146 is configured to operate with external MOSFET drivers, such as the SC1405, in high efficiency synchronous applications (See Evaluation Board Schematic). The SC1146 based dc/dc converter consists of four buck converter controllers integrated and synchronized. The high clock frequency allows for smaller inductor values and miniature surface mount, low inductance output capacitors. Since each stage has $\frac{1}{4}$ the output current, the conduction losses in each stage is reduced by a factor of 1/16. Precision active trimming ensures 1% matching of duty cycles among phases, thus ensuring the heat and component stress is shared equally. The SC1146 may also be configured in asynchronous mode by using buffer transistors.

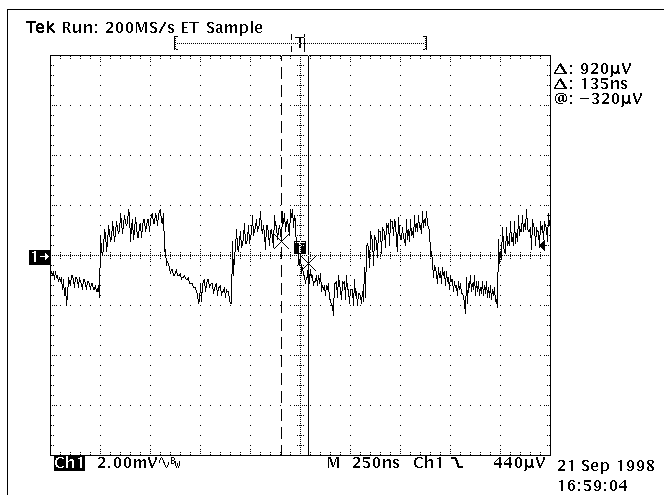


Fig. 1: V_{OUT} Ripple, $V_{OUT} = 1.0V$, $I_{OUT} = 30A$

DECODER/BIAS GENERATOR/PWM CONTROLLER

The 8 MHz clock is divided down to 2 MHz for four phase operation by the clock decoder. The start of the output pulses are time shifted 90 degrees by the decoder with respect to each other. The Bias Generator generates the ramps to each phase by a precision trimmed current source and on-chip capacitors. The decoder, which is synchronized to the bias generator via the master clock, phase shifts the ramps and en-

ables the PWM controller sequentially. A resistor from R_{REF} pin to FBG programs the frequency and ramp time.

$$\text{Clock Freq} = (8.2K/R_{ref}) * 8\text{Mhz}$$

The ramps are then compared to the error amplifier output at the high speed PWM comparator inputs. The controller outputs are buffered versions of the comparator outputs.

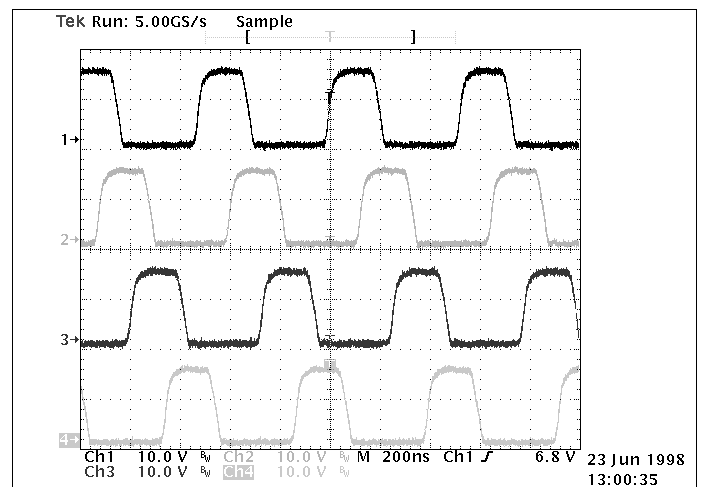


Fig. 2: The four Gate Drives firing 90° out of phase.
 $V_{OUT} = 1.0V$, $I_{OUT} = 10A$, $V_{CC2} = 12V$, Asynchronous operation.

ERROR AMPLIFIER

At the heart of the controller is an ultra-fast, transconductance error amplifier. Since the output inductor values can be selected to be a minimum, usually less than a micro-Henry, the delays due to inductor ramp time are minimized during transient load recovery. The higher frequency of operation also allows use of much smaller capacitance on the output. This means that the dc/dc converter output capacitors "hold time" is less. The error amplifier must therefore respond extremely fast "Recover the Fort" after a transient. The SC1146 error amplifier recovers to its normal duty cycle after application of a full load transient within 2 usec maximum, (largely dependant on supply quality) and usually within 1usec. This minimizes undershoot and overshoot during application of a transient.

July 25, 2000

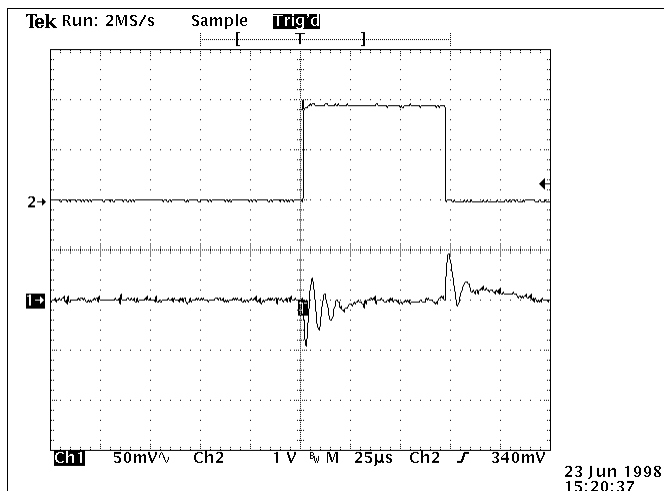
ERROR AMPLIFIER CONT.


Fig. 3: Transient response, Top trace, Current sense 8A/div @ 30A/usec. Bottom trace, V_{OUT} .

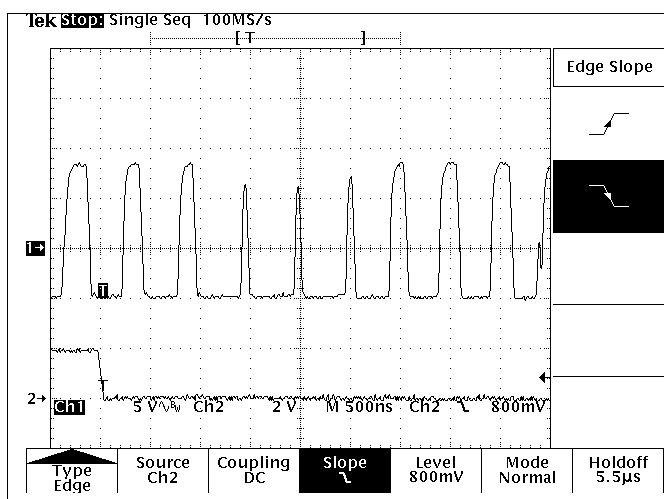


Fig. 4: Transient response, Top trace, Gate Drive Bottom trace, Transient current 16A/div @ 30A/usec.

The error amplifier has two inverting inputs, one for the High Range, (VID4 set to logic high) and one input for the Low Range. The effective gain of the error amplifier stays constant in both ranges keeping the loop gain constant regardless of output voltage range.

BANDGAP REFERENCE/SOFT START

The precision internal bandgap reference provides a stable, temperature compensated 2.05 V reference for the error amplifier's non-inverting input, the DAC_{REF} for the VID digital to analog converter, the under-voltage lock-out circuitry as well as the reference for the Bias generator current sources. The error amplifier's non-inverting input is connected to the bandgap reference through a 3Kohm resistor, which is also externally connected to a soft-start capacitor via the BG_{OUT} pin. Upon application of power, the non-inverting input of the error amplifier is held low for a short time, set by the RC product of the soft-start capacitor and 3Kohm, allowing for the decoder and PWM controller to settle. This prevents any harmful output voltage overshoots upon start up or after a converter shut-down (as a result of over-current or the enable pin pulled low). The non-inverting input then ramps up according to the RC time constant allowing gradual rise of output voltage.

OVER-CURRENT COMPARATOR

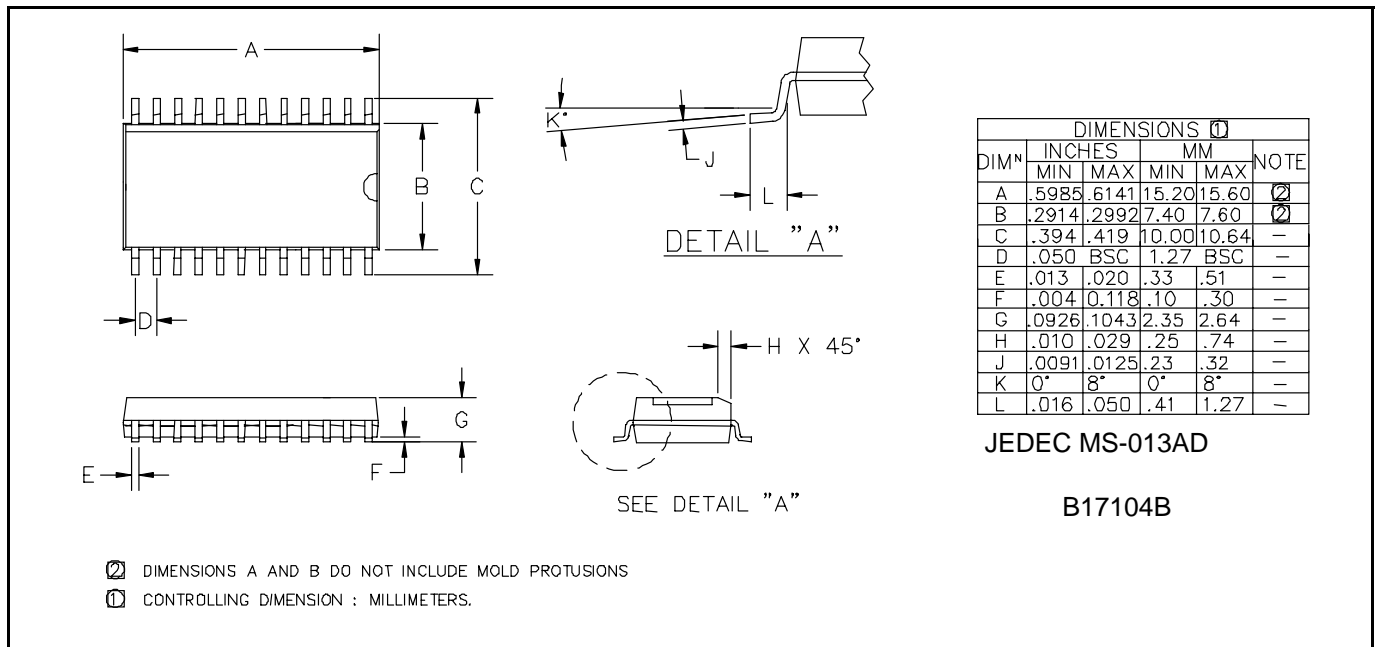
The SC1146 has an internal over-current comparator designed to sense current in the input supply path. The comparator inputs have a high common voltage range thus allowing operation under all possible voltage/current combinations. The output of the comparator pulls the BG_{OUT} (soft start) pin low thus disabling the error amplifier and causing the PWM outputs to enter minimum duty cycle mode, regulating the output at a minimum voltage. A current sense trace may be used as the current sense resistor. This will utilize the trace as input filter inductor, thus preventing conducted emissions to input supply. For details of programming the overcurrent comparator, refer to SC1144-EVB user manual.

SC1146 Special features:

The SC1146 is a special version of the original SC1144, 4-phase PWM controller, with the latest VRM9.0 VID codes which allow programming lower output voltages required by the latest Microprocessors. Also a +12V supply is no longer required. The V_{CC2} and PWRGOOD pins can be connected to V_{CC5V}. This eases the connection to "5V-only" MOSFET drivers, such as the SC1405. The DRVs will swing to V_{CC5V}, eliminating the need for +12V to +5V level shifting. There is no Under-Voltage Lockout on V_{CC2}.

July 25, 2000

An evaluation board is available which may be ordered directly from the factory. SC1146/1405EVB is a DC/DC converter utilizing the SC1146 four-phase controller in a high current synchronous application. The evaluation board is intended as a guideline for board design, layout and to assess key performance parameters, such as transient response, thermal stress management and input and output ripple considerations. The SC1146EVB includes a DIP switch for mode/voltage selection as well as qualified selection of components for the SC1146 operation. The SC1144EVB user manual contains useful general applications information applicable to SC1146 and may be accessed from our website at www.semtech.com.

OUTLINE DRAWING - SO-24


ECN00-1215