

AN6154NK, AN6154NS

Speech Network IC

Overview

The AN6154NK and AN6154NS are speech network circuits capable of switching side-tone preventive networks. They incorporate an ECM power supply (typically 1.3 V), and are operable at as low as 1.8 V.

Features

- Operable at as low as a 1.8 V line voltage.
- Incorporates an ECM power supply for easier interface with peripheral devices.
- Automatically adjusts the transmitter/receiver gain according to line current.
- Can select one of two side-tone preventive networks according to line current.
- Selection of side-tone preventive networks and control of the transmitter/receiver gain are possible from outside.
- The receiver gain is switchable between 0 and 6 dB.

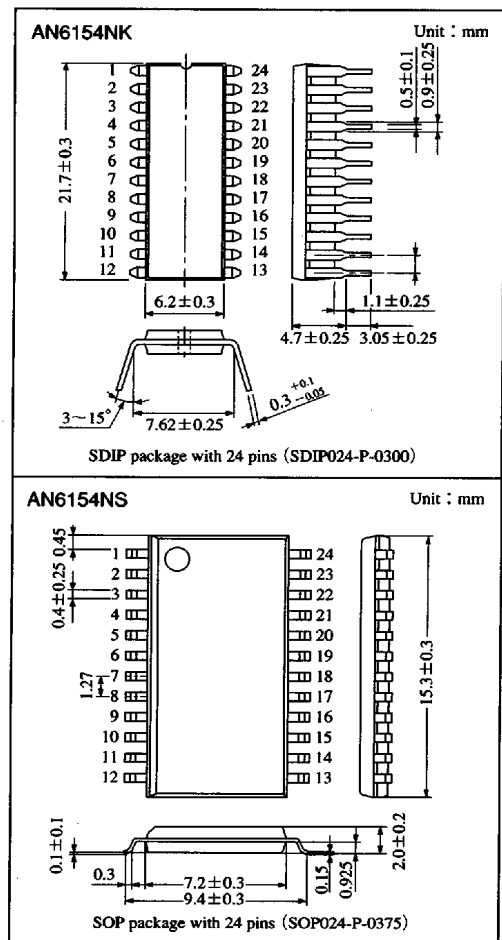

Block Diagram

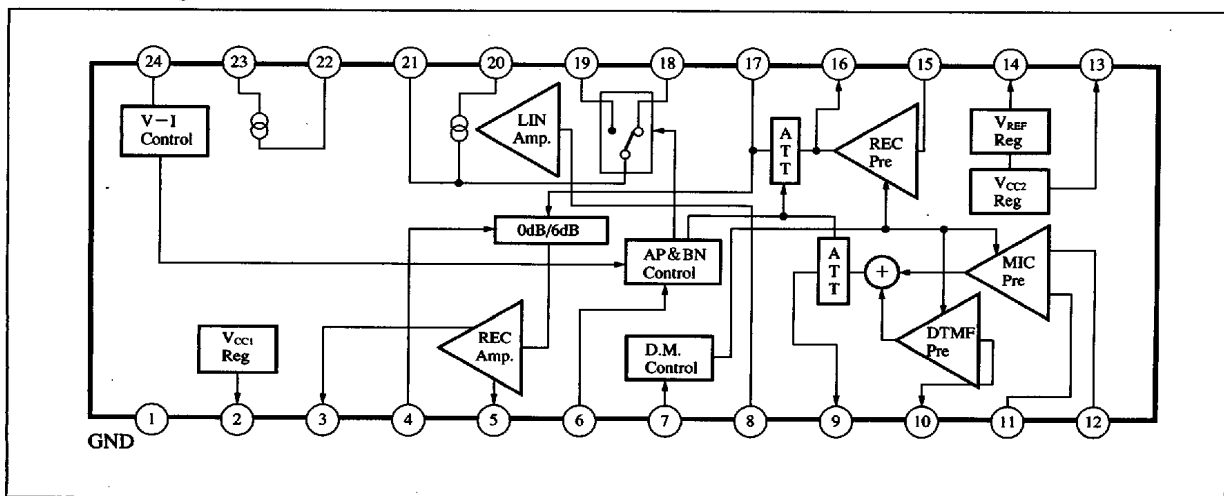

6932852 0013049 30T

Panasonic

■ Absolute Maximum Ratings (Ta=25°C)

Parameter	Symbol	Rating	Unit	
Supply voltage *1	V _L	14.4	V	
Supply current *1	I _L	120	mA	
Internal supply current *3	I _{CC1}	20	mA	
APC voltage *4	V ₆	V _{CC1} +0.3V	V	
DMC voltage *4	V ₇	V _{CC1} +0.3V	V	
Power dissipation *2 (Ta=60°C)	AN6154NK	P _D	700	mW
	AN6154NS			
Operating ambient temperature	T _{opr}	-20 to +75	°C	
Storage temperature	T _{stg}	-55 to +125	°C	

*1 V_L and I_L are input voltage and current measured at pin 21 respectively.

*2 The P_D rating must be observed.

*3 I_{CC1} is the line current measured at pin 2. No voltage other than the line voltage must be applied to this pin.

*4 V_{CC1} is the line voltage measured at pin 2.

■ Recommended Operating Range (Ta=25°C)

Parameter	Symbol	Range
Operating supply voltage range	V _L	3V~11.5V

■ Electrical Characteristics (Ta=25°C)

Parameter	Symbol	Condition	min.	typ.	max.	Unit
Receiver system						
Receiver gain	G _{V-R}	I _L =30mA, V _i =-40dBV	31.5	34	36.5	dB
Receiver automatic pad	A _{P-R}	I _L =80mA to 30mA, V _i =-40dBV	-6.8	-5.3	-3.8	dB
Receiver gain control	G _{V-d}	I _L =30mA, V _i =-40dBV	5	6	7	dB
Maximum receiver signal level	V _{O-R}	I _L =30mA, THD=5%	-1	2	—	dBV
KEY-IN TONE gain	G _{V-KT}	I _L =30mA, V _i =-30dBV	14.5	17	19.5	dB
Transmitter system						
Transmitter gain	G _{V-T}	I _L =30mA, V _i =-50dBV	37.5	40	42.5	dB
Transmitter automatic pad	A _{P-T}	ΔI _L =80mA to 30mA, V _i =-50dBV	-4.8	-3.5	-2.1	dB
Maximum output	V _{O-T}	I _L =30mA, THD=5%	-2	1.3	—	dBV
DTMF gain	G _{V-DT}	I _L =30mA, V _i =-50dBV	30	32	34	dB
DTMF automatic pad	A _{P-DT}	ΔI _L =80mA to 30mA, V _i =-50dBV	-4.8	-3.4	-2.1	dB
Maximum DTMF output	V _{O-DT}	I _L =30mA, THD=5%	-2	1.3	—	dBV
Power supply						
DC line voltage (1)	V _{L-1}	I _L =20mA	3	3.5	4	V
DC line voltage (2)	V _{L-2}	I _L =120mA	6.3	6.8	7.3	V
Internal supply voltage (1)	V _{CC1-1}	I _L =20mA	2.2	2.45	2.7	V
Internal supply voltage (2)	V _{CC1-2}	I _L =120mA	2.2	2.45	2.7	V
Internal supply voltage (1)	V _{CC2-1}	I _L =20mA	1.1	1.3	1.5	V
Internal supply voltage (2)	V _{CC2-2}	I _L =20mA	1.1	1.3	1.5	V
Dial mute input						
Dial mute OFF	V _{DM-H}		0.9	—	V _{CC1}	V
Dial mute ON	V _{DM-L}		—	—	0.3	V
AP control						
BN-1 ON	I _{L-BN1}		—	54	61	mA
BN-2 ON	I _{L-BN2}		40	46	—	mA

Note) Unless otherwise specified, input signal frequency (f_{in}) is 1 kHz.

■ 6932852 0013050 021 ■

Panasonic

759

Application Circuit

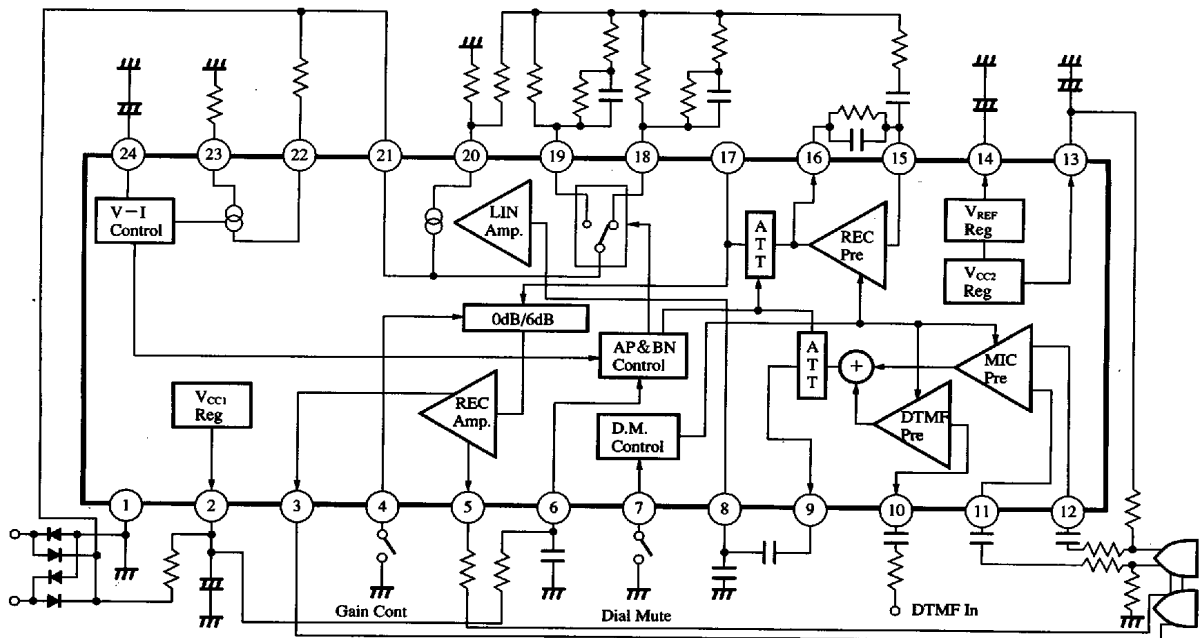

Pin Descriptions

Pin No.	Description	Pin No.	Description
1	Ground	13	Regulated power supply (2) Output
2	Regulated power supply (1) Output	14	Reference voltage output
3	Receiver output (1)	15	Receiver preamplifier input
4	Receiver gain switching control	16	Receiver preamplifier output
5	Receiver output (2)	17	To a receiver output amplifier
6	AP/BN switching control	18	To a long-distance side-tone preventive network (BN1)
7	Dial muting control	19	To a short-distance side-tone preventive network (BN2)
8	Line amplifier input	20	Side-tone adjustment
9	Transmitter preamplifier output	21	To the positive line
10	DTMF input	22	Line current bypass (2)
11	Transmitter input (1)	23	Line current bypass (1)
12	Transmitter input (2)	24	Line voltage control

Supplementary Explanation

Designed Electrical Characteristics (Ta=25°C)

Parameter	Symbol	Condition	min.	typ.	max.	Unit
AC impedance (1)	Z _{AC-1}	I _L = 30mA, Fin = 1kHz	400	650	800	Ω
AC impedance (2)	Z _{AC-2}	I _L = 80mA, Fin = 1kHz	400	610	800	Ω

6932852 0013051 T68

Panasonic