

DATA SHEET

NE57610

Li-ion battery charger control
with adjustable thresholds

Product data

2002 Nov 05

Li-ion battery charger control with adjustable thresholds

NE57610

DESCRIPTION

The NE57610 is a one- or two-cell, Li-ion battery charger controller which includes: constant-current and constant-voltage charging, a precise charge termination, pre-charging of undervoltage cells, overcharge timer, and under- and over-temperature detection.

The NE57610 is available in the very small TSOP-24A package.

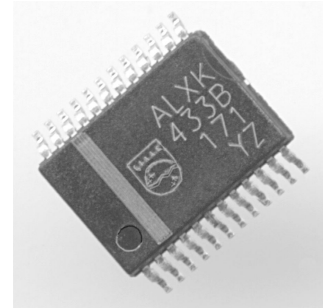

FEATURES

- 30 mV per cell charging accuracy from 0 °C to +50 °C
- Low quiescent current
- Undervoltage pre-charge conditioning and timer
- Battery overtemperature detection and protection
- Input voltage OK detection
- Self-discharge maintenance charging
- Overcharge timer
- LED drivers

APPLICATIONS

- Controls charging of Lithium-ion batteries

SIMPLIFIED SYSTEM DIAGRAM

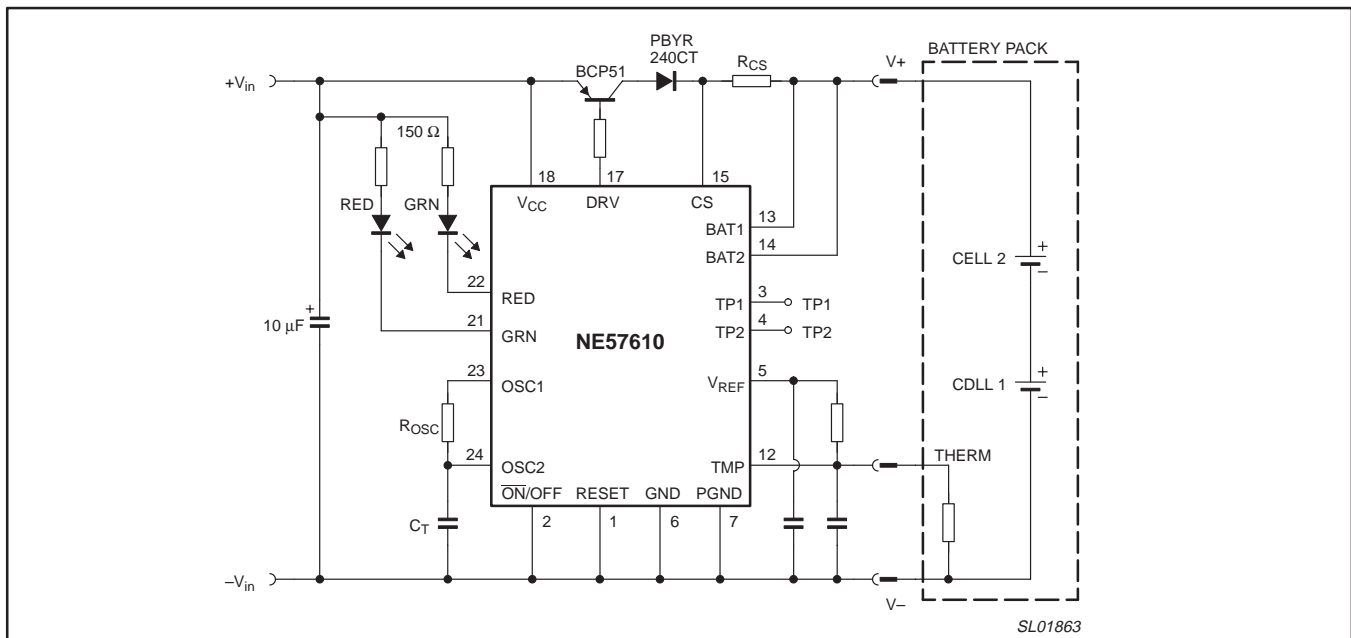

Figure 1. Simplified system diagram.

Li-ion battery charger control with adjustable thresholds

NE57610

ORDERING INFORMATION

TYPE NUMBER	PACKAGE		TEMPERATURE RANGE
	NAME	DESCRIPTION	
NE57610BDH	TSOP24A	24-pin thin small outline	-20 °C to +70 °C
NE57610EDH	TSOP24A	24-pin thin small outline	-20 °C to +70 °C
NE57610YDH	TSOP24A	24-pin thin small outline	-20 °C to +70 °C

Voltage options

Part number	Output voltage	Over-voltage detection threshold	Cells
NE57610BDH	8.4 V	8.7 V	2-cell
NE57610EDH	4.2 V	4.35 V	1-cell
NE57610YDH	4.1 V	4.35 V	1-cell

MAXIMUM RATINGS

SYMBOL	PARAMETER	Min.	Max.	UNIT
V _{CC(max)}	Power supply voltage	-0.3	15	V
T _{amb}	Ambient temperature	-20	+70	°C
T _{stg}	Storage temperature	-40	+125	°C
P _D	Power dissipation	-	250	mW

PIN CONFIGURATION

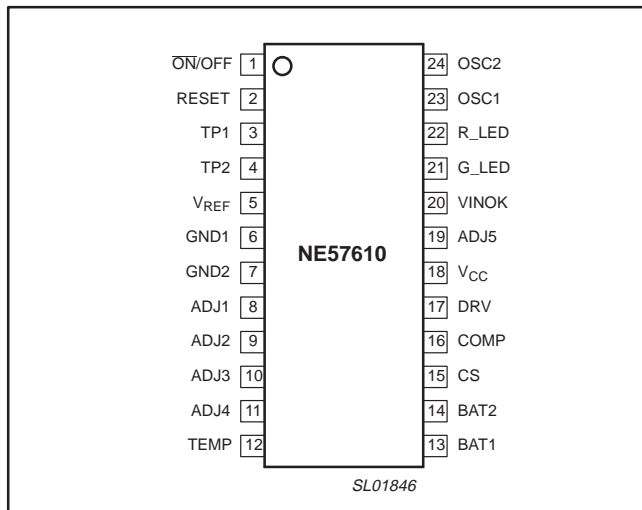

Figure 2. Pin configuration.

Li-ion battery charger control with adjustable thresholds

NE57610

PIN DESCRIPTION

PIN	SYMBOL	I/O	DESCRIPTION
1	ON/OFF	I	ON/OFF: When LOW, the charger operates. When HIGH, it inhibits all functions of the charger.
2	RESET	I	RESET: In a LOW state all charger functions are enabled. When the pin is brought HIGH, all of the charger functions are inhibited and when brought to a LOW state again, all of the timers are initialized and the start-up functions are enabled.
3	TP1	O	Test Point 1: This pin is the output of the center counter of the pre-charger timer counter. This pin will slowly toggle between a HIGH state and a LOW state during the pre-charge period.
4	TP2	O	Test Point 2: This pin is the output of the center counter in the high-rate charger counter. This pin will slowly toggle between a HIGH state and a LOW state during the high-rate charging period.
5	V _{REF}	O	Reference voltage: This is an output of a temperature stabilized 1.2 V reference. It is used in the bias of the thermocouple and for adjustment of the ADJ1–ADJ4 pins.
6	GND1	–	Ground.
7	GND2	–	Ground.
8	ADJ1	I	Overcurrent threshold adjustment pin: This pin is internally set to 1.16 V. The overvoltage trip point is set too high at this voltage to become active. This is useful where the input power source is a current-limited wall transformer. It may be adjusted by referring to 'Use of the ADJ1–ADJ4 pins'.
9	ADJ2	I	Charge termination current threshold adjustment pin: At the top-of-charge, when the charge current falls below this level, the charging cycle is terminated. This pin is internally set to 62 mV. It may be adjusted by referring to 'Use of the ADJ1–ADJ4 Pins'.
10	ADJ3	I	Pre-charge current adjustment pin: This adjusts the amount of current entering the battery during the pre-charge period. It is internally set to 120 mV. It may be adjusted by referring to 'Use of the ADJ1–ADJ4 Pins'.
11	ADJ4	I	High-rate current adjustment pin: This pin controls the amount of charge current during the high-rate of charge period. The pin is internally set to 89 mV. It may be adjusted by referring to 'Use of the ADJ1–ADJ4 Pins'.
12	TEMP	I	Battery temperature sensing pin: This pin inhibits the charging process if the voltage presented to this pin falls outside an acceptable temperature range. The external voltage is created by resistor network that includes a thermocouple.
13	BAT1	I	Battery voltage sensing pin: This pin senses the battery voltage.
14	BAT2	I	Battery voltage and current sensing pin: This pin senses battery voltage but also is one of the two leads for sensing charging current. (CS is the other current sensing pin.)
15	CS	I	Current sensing pin: This pin is one of the two current sensing pins. (BAT2 is the other pin.)
16	COMP	I	Current regulation amplifier compensation pin: It is recommended that around 100 pF be connected between this pin and the DRV pin. This capacitor improves the phase margin of the system.
17	DRV	O	External PNP transistor base drive pin: This pin directly drives the base of an external PNP bipolar transistor.
18	V _{CC}	I	The positive voltage supply pin.
19	ADJ5	I	Full charge termination voltage adjust pin: This pin, when grounded will increase the termination voltage by 15 mV.
20	VINOK	I	Input voltage overvoltage indicator: This pin is LOW if the input voltage is over the maximum input voltage. The pin is HIGH when the input voltage is not above the maximum input voltage.
21	G_LED	O	Green LED driver pin. This is an open collector output which is connected to a green LED though a series resistor to limit the current to less than 20 mA to the input voltage.
22	R_LED	O	Red LED driver pin. This is an open collector output which is connected to a red LED though a series resistor to limit the current to less than 20 mA to the input voltage.
23	OSC1	O	Oscillator out pin: This pin is connected through a timing resistor to the OSC2 pin to set the frequency of the oscillator and the period of the timers.
24	OSC2	I	Oscillator in pin: This pin is connected through a timing resistor to the OSC1 pin and a timing capacitor to V _{SS} . This sets the frequency of the oscillator and the period of the timers.

Li-ion battery charger control with adjustable thresholds

NE57610

DC ELECTRICAL CHARACTERISTICS

Characteristic of the NE57610Y.

SYMBOL	PARAMETER	CONDITIONS	Pin	Min.	Typ.	Max.	UNIT
I_{CC}	Supply current		18	–	5.0	7.0	mA
V_{REF}	Reference voltage		5	–	1.207	–	V
V_{ADPL}	AC Adaptor detection voltage L	$V_{CC}: H \rightarrow L$	20	2.35	2.45	2.55	V
$V_{ADPL(hys)}$	AC Adaptor detection voltage L Hysteresis voltage		20	50	100	150	mV
V_{ADPH}	AC Adaptor detection voltage H	$V_{CC}: L \rightarrow H$	20	6.1	6.3	6.5	V
$V_{ADPH(hys)}$	AC Adaptor detection voltage H Hysteresis voltage		20	50	100	150	mV
Z_{ADPL}	Impedance for AC Adaptor detection output L		20	–	30	–	k Ω
I_{BAT}	BAT pin leakage current		13, 14, 15	–	–	1	μ A
V_{BAT}	BAT pin output voltage	$T_{amb} = 0 \sim +50 \text{ }^\circ\text{C}$	13	4.070	4.100	4.130	V
V_{DRV}	DRV pin output voltage	$I_{DRV} = 20 \text{ mA}$	17	–	–	0.5	V
$I_{\overline{ON}/OFF}$	\overline{ON}/OFF pin input current		1	40	60	80	μ A
$V_{\overline{ON}/OFF}$	\overline{ON}/OFF pin input voltage H	$\overline{ON}/OFF: OFF$	1	0.6	–	1.20	V
$V_{\overline{ON}/OFF}$	\overline{ON}/OFF pin input voltage L	$\overline{ON}/OFF: ON$	1	–	–	0.25	V
I_{reset}	RESET pin input current		2	40	60	80	μ A
$V_{reset(high)}$	RESET pin input voltage H	Charge control circuit: OFF	2	0.6	–	1.20	V
$V_{reset(low)}$	RESET pin input voltage L	Charge control circuit: ON	2	–	–	0.25	V
V_{L1}	Current limit 1	Quick charge	14, 15	0.20	0.22	0.24	V
V_{L2}	Current limit 2	Pre-charge	14, 15	21	26	31	mV
V_F	Full charge detection	$R_{CS} \cdot I_{charge}$	14, 15	13	18	23	mV
V_{LV}	Undervoltage voltage detection voltage	$V_{BAT}: L \rightarrow H$	13	1.90	2.00	2.10	V
$V_{LV(hys)}$	Low voltage detection voltage Hysteresis voltage		13	25	50	100	mV
V_P	Pre-charge detection voltage	$V_{BAT}: L \rightarrow H$	13	2.80	2.90	3.00	V
$V_{P(hys)}$	Pre-charge detection voltage Hysteresis voltage		13	25	50	100	mV
V_R	Re-charge detection voltage	$V_{BAT}: H \rightarrow L$	13	3.85	3.90	3.95	V
V_{OV}	Overvoltage detection voltage	$V_{BAT}: L \rightarrow H$	13	4.30	4.35	4.40	V
V_{TH}	Battery temperature detection voltage H	Low temperature $3 \text{ }^\circ\text{C} \pm 3 \text{ }^\circ\text{C}$ detection	12	0.835	0.860	0.885	V
V_{TL1}	Battery temperature detection voltage L1	High temperature $43 \text{ }^\circ\text{C} \pm 3 \text{ }^\circ\text{C}$ detection (charging start)	12	0.390	0.413	0.435	V
V_{TL2}	Battery temperature detection voltage L2	High temperature $50 \text{ }^\circ\text{C} \pm 3 \text{ }^\circ\text{C}$ detection (during charging)	12	0.335	0.353	0.370	V
I_T	TDET input bias current		12	–	30	150	nA
V_{LEDR}	R_LED pin output voltage	$I_{LEDR} = 10 \text{ mA}$	22	–	–	0.4	V
V_{LEDG}	G_LED pin output voltage	$I_{LEDG} = 10 \text{ mA}$	21	–	–	0.4	V
ΔT	Timer error time	Not including external deviation (Note 2)	21, 22	–10	–	10	%

NOTES:

- Current limits 1 and 2 and full charge detection are specified as current detection resistor voltage drop.
- Use a capacitor with good temperature characteristics in the oscillator. Capacitor deviation will contribute to timer error.

Li-ion battery charger control with adjustable thresholds

NE57610

TIMING DIAGRAMS

Typical timing for the NE57610Y.

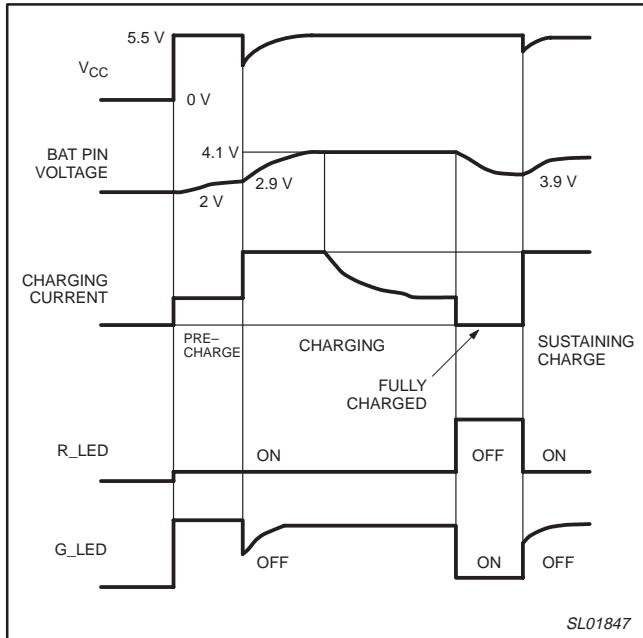

Figure 3. Normal charging.

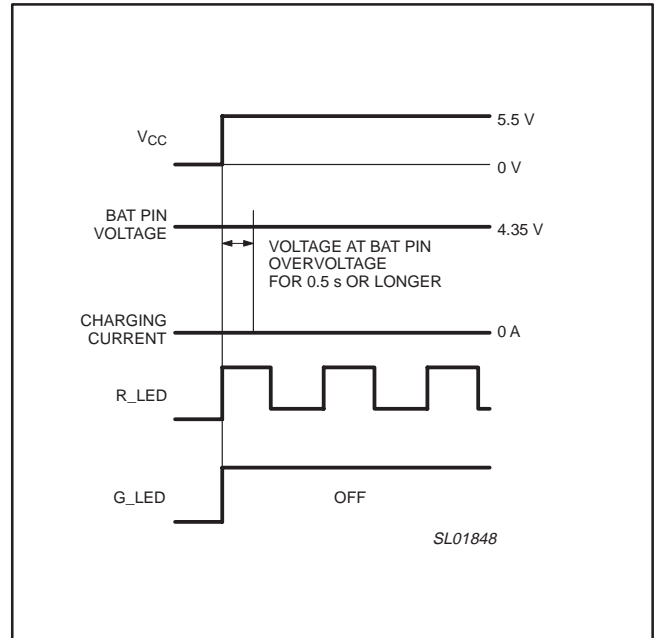

Figure 4. Battery overcharge detection.

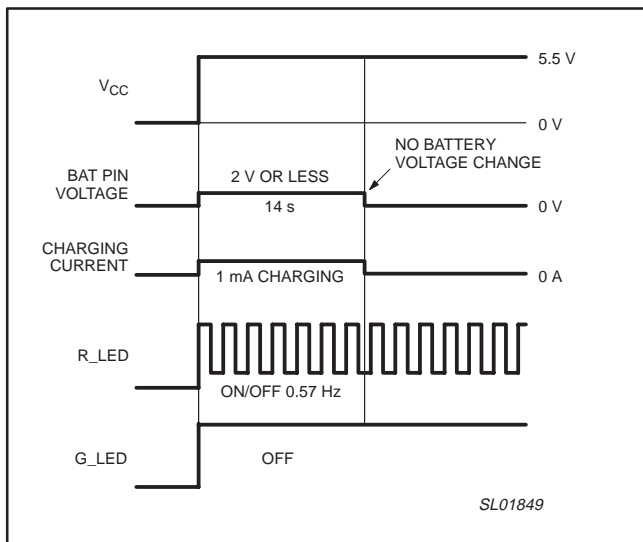

Figure 5. Battery overdischarge detection.

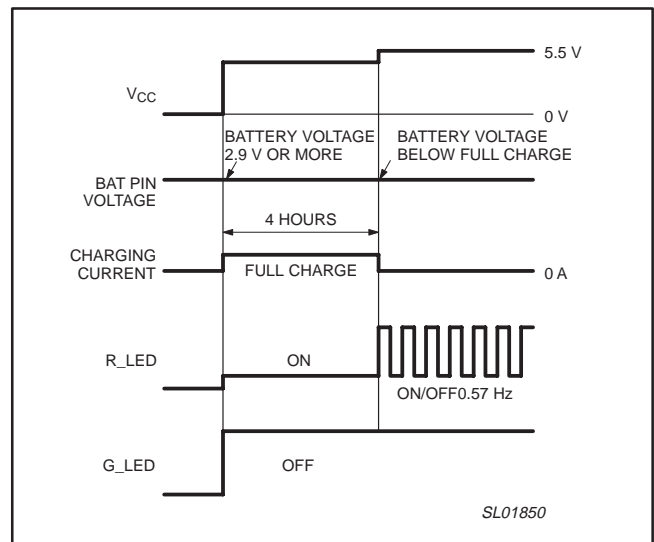

Figure 6. Battery charge time-out.

Li-ion battery charger control with adjustable thresholds

NE57610

TIMING DIAGRAMS (continued)

Typical timing for the NE57610Y.

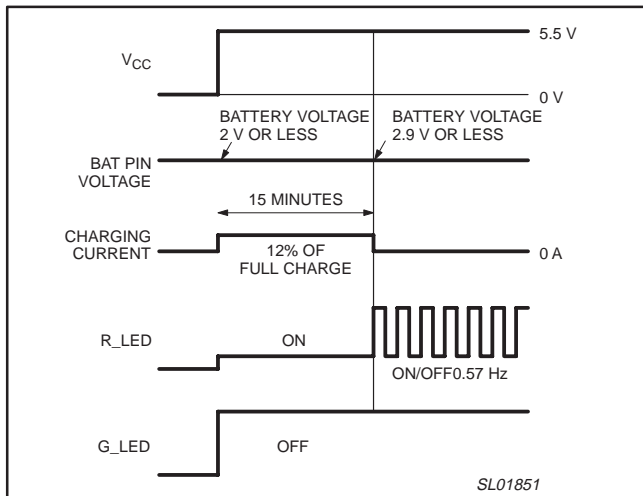

Figure 7. Conditioning charge failure.

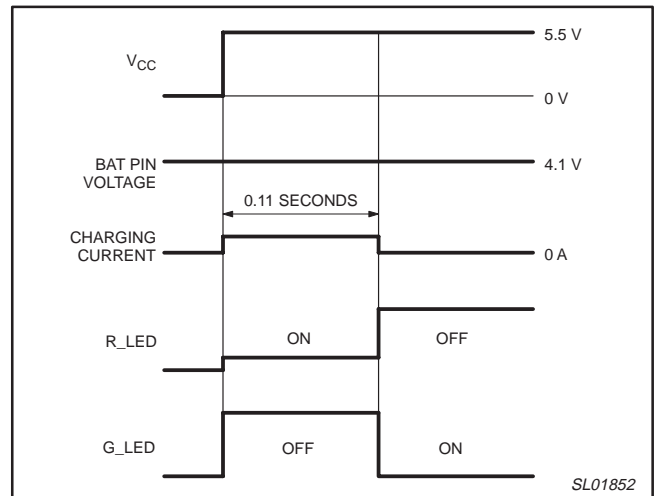

Figure 8. Battery full charge detection.

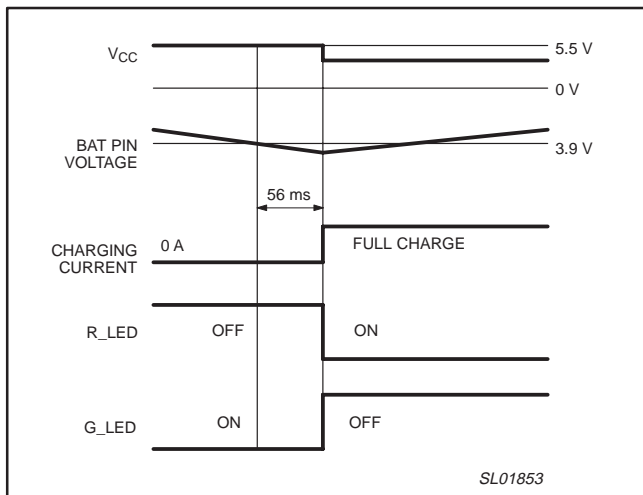

Figure 9. Battery topping-off charge.

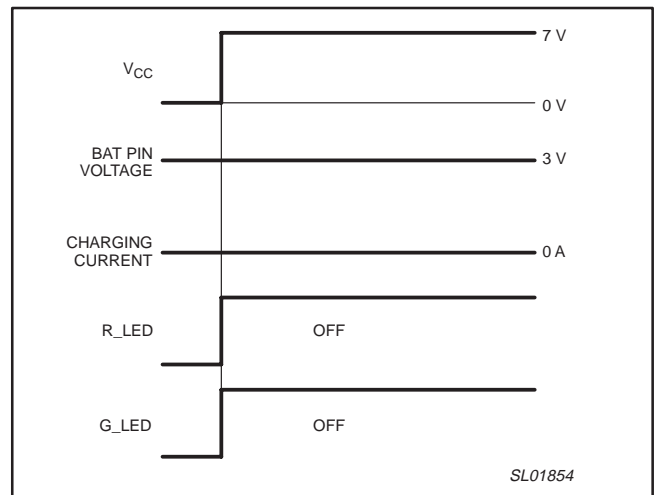

Figure 10. Supply (adaptor) overvoltage detection.

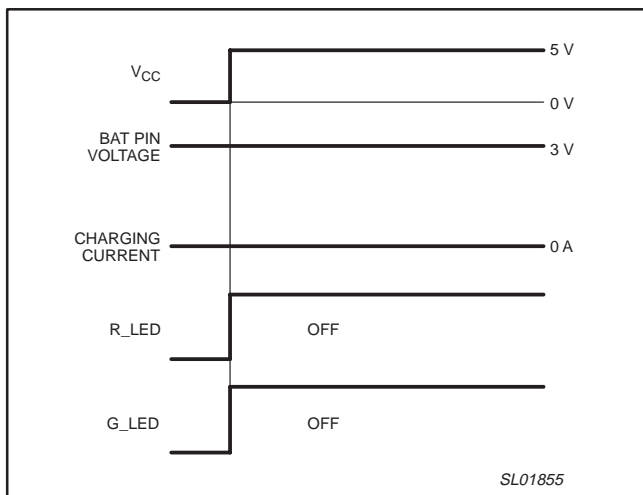

Figure 11. Temperature detection pin open.

Li-ion battery charger control with adjustable thresholds

NE57610

TYPICAL PERFORMANCE CURVES

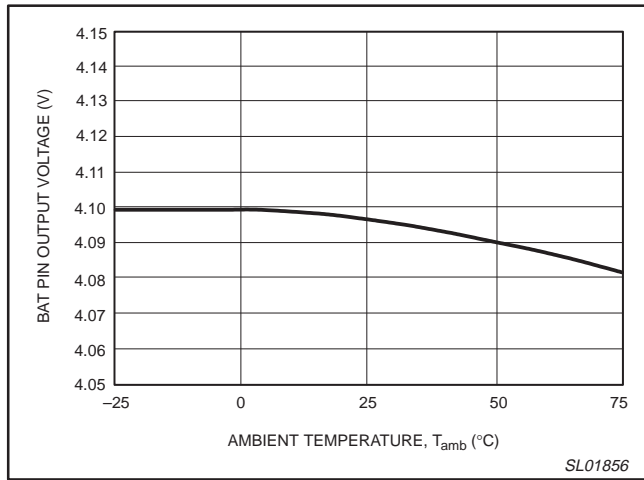

Figure 12. BAT output voltage versus temperature.

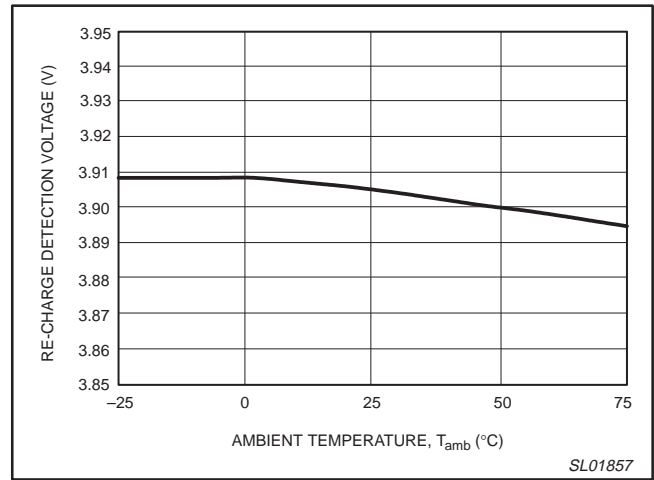

Figure 13. Re-charge detection voltage versus temperature.

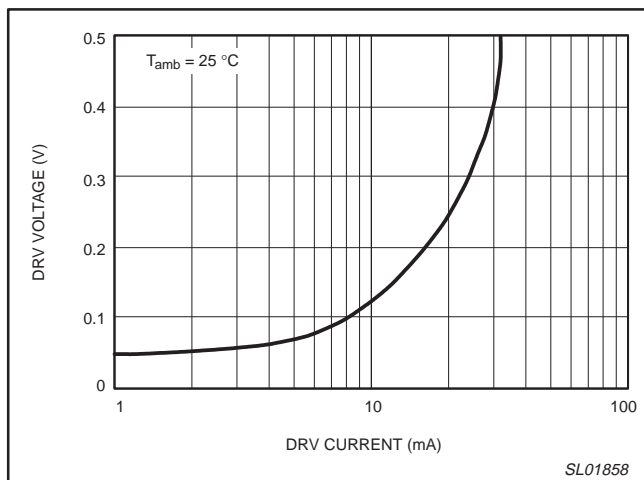

Figure 14. DRV voltage versus DRV current.

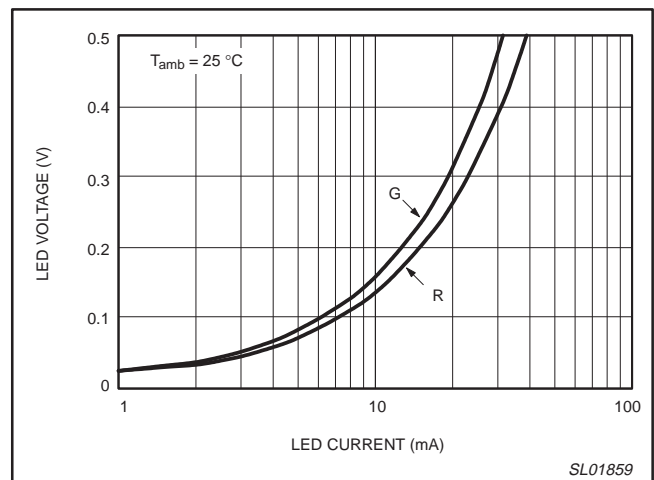

Figure 15. LED voltage versus LED current.

Li-ion battery charger control with adjustable thresholds

NE57610

TECHNICAL DISCUSSION

Lithium-ion cells: general information

Lithium-ion and polymer cells have higher voltage than nickel cadmium (NiCd) or nickel metal hydride (NiMH) rechargeable cells. The average operating voltage of a lithium-ion or polymer cell is 3.6 V compared to the 1.2 V of NiCd and NiMH cells. The internal resistances of the various types of lithium cells are 50 mΩ to 300 mΩ, compared to the 5 mΩ to 50 mΩ of the nickel chemistries. This makes Lithium-ion and polymer cells better for lower battery current applications, less than 1 ampere, such as cellular and wireless telephones, palmtop and laptop computers, etc.

Lithium-ion and polymer cells are safe as long as the cell is maintained within a particular set of operating boundaries. The cells have a porous carbon, or graphite anode where individual lithium ions can lodge themselves within the pores. This keeps the lithium ions separated, and any hazardous condition is avoided, if the cell is kept within the safe operating boundaries.

A lithium cell protection circuit is placed within the battery pack. It monitors the level of voltage across each cell for overcharge and overdischarge conditions, and the discharge current in the event of an overcurrent or short-circuit condition. If the lithium cell is overcharged, pure metallic lithium plates out onto the surface of the anode. Also volatile gas is generated within the cell. This creates a hazard. Conversely, if the cell were allowed to over-discharge (V_{cell} less than typically 2.3 V), the chemistry of the cell changes and the copper metal used in its construction enters the electrolyte solution. This severely shortens the cycle life of the cell, but presents no future safety hazard. When the cell experiences high charge or discharge currents, then the internal series resistance of the cell creates heating and generation of the volatile gas which could again present a hazard.

Charging lithium cells

An integral part of any Li-ion battery system is a battery charger specifically designed for the lithium cell being used, with its particular over and undercharge limits, capacity, etc. The battery charger should be viewed as a part of the entire lithium battery system so that safe cell operation can be ensured.

Lithium cells must be charged with a dedicated charging controller such as the NE57610. The charging ICs, in general, can be described as performing: a current-limited, constant-voltage charge process. When the cell is very discharged, the charger IC outputs a constant current into the battery, which limits the internal heating of the cells. The maximum charge rate is typically the capacity rating of the cell. That is, the maximum charge current is the mAh rating of the cell(s), that is, a 1000 mAh cell will be charge with a maximum of 1000 mA. When the cell voltage approaches its full-charged voltage rating (V_{OV}), the current entering the cell begins to decrease, and the charger IC provides a constant voltage-mode of charge. The charge current begins to exponentially decrease over a long period of time (approximately 1.5 – 2.0 hours). When the charge current falls below a preset amount, the charge current is discontinued.

If charging begins with the cell voltage below the overdischarged voltage rating of the cell (V_{UV}), it is very important to slowly raise the cell voltage up to this overdischarged voltage level. This is done with a **reconditioning charge**. A small amount of current is allowed into the cell, and the cell voltage is allowed, for a pre-set period of time, to rise to the overdischarged voltage (V_{UV}). If the cell voltage recovers, a normal charging sequence can begin as described above. If the cell does not reach the overdischarged voltage level, then the cell is considered too damaged to charge and the charge is discontinued.

It is important to allow enough time to charge the cell to take advantage of the higher energy density of the lithium cells. When the charger switches from constant current charge to constant voltage charge (Point B, Figure 16) the cell only contains about 80 percent of its full-rated capacity. When the cell is 100 mV less than its full rated charge voltage, the capacity contained within the cell is about 95 percent. Allowing the cell to slowly complete its charge takes advantage of the larger capacity of the lithium cells. The complete charging curve can be seen in Figure 16.

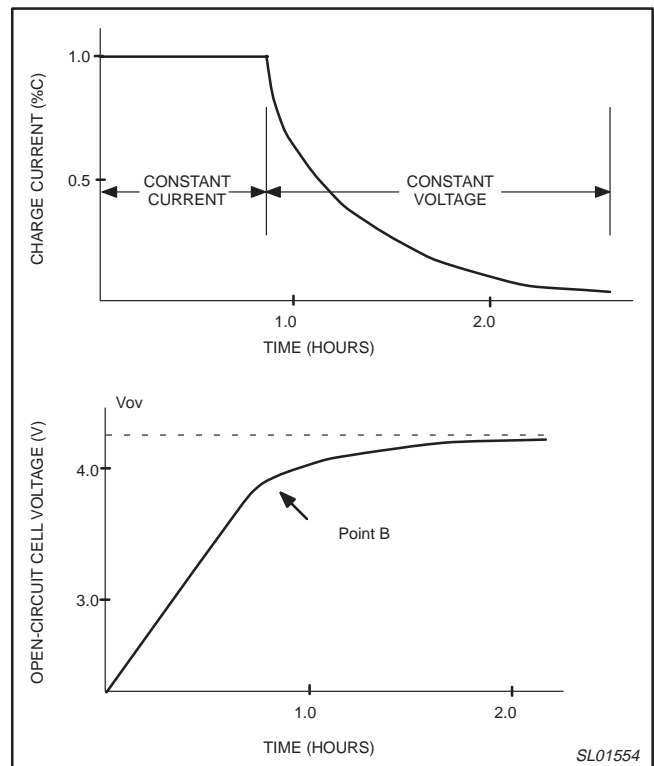

Figure 16. Lithium-ion charging curves.

Li-ion battery charger control with adjustable thresholds

NE57610

NE57610 OPERATION

The typical application schematic is given in Figure 17. Because in a multiple-cell battery pack, the battery charger cannot access the connection(s) between the cells within a battery pack, the following discussion is based upon the calculated value of each cell's voltage ($V_{batt}/\text{number of series cells}$).

Start of charging

The start of the charging process is only permitted when all of the following conditions are met:

- The DC input voltage is greater than V_{ADPH} , which indicates there is sufficient input voltage.
- The battery voltage is less than the overcharged voltage (V_{OV})
- The reset and $\overline{ON/OFF}$ pins are both LOW.
- The battery temperature voltage falls within its recommended operating range.

The charging behavior depends on the voltage of the battery. If the initial cell voltage is:

< 2.0 V (V_{LV}) (overdischarged): A 1 mA charge current is sent into the battery pack and the undervoltage charge timer is set. If the battery pack voltage does not reach 2.3 V (or V_{UV}) in this preset period of time, the pack is assumed to be damaged and the charging process is terminated. The charger can be restarted by bringing RESET momentarily high, or by turning-OFF and then ON the input voltage.

2.3V (V_{UV}) < V_{batt} < 2.9 V (V_P): A charge current of approximately $1/8^{\text{th}}$ the normal charge current (pre-charge) is placed into the battery pack. This continues until the cell voltage reaches 2.9 V. If the pre-charge timer, times out prior to the cell reaching 2.9 V, the pre-charge is terminated. The charger can be restarted by bringing RESET momentarily high, or by turning-OFF and then ON the input voltage.

2.9 V (V_P) < V_{batt} < 4.35 V (V_{OV}): The high-rate charge current is placed into the battery pack until the cell reaches a full-charge condition by either reaching V_{OV} or V_F . If the cell does not reach the full-charge level within the period of the charge timer, the charge is terminated.

V_{batt} > 4.35 V (V_{OV}) (fully charged): The charge current is completely cut off. If the battery pack is allowed to remain on the charger for an extended period, and if the pack voltage falls to 3.9 V per cell due to self-discharge, charging begins again at the full rate of charge until V_{OV} or V_F is reached again. This process repeats as long as the battery is in the charger.

Overriding conditions

If, under any of the above conditions, the following conditions are encountered, the charging process will be immediately terminated.

- If the temperature sensing input is lower than V_{TH} or higher than V_{TL} voltages. (remember, a thermocouple's voltage goes down with higher temperatures)
- If the timer associated with the presently active function times out.

A State diagram of the various modes of the charger can be seen in Figure 18.

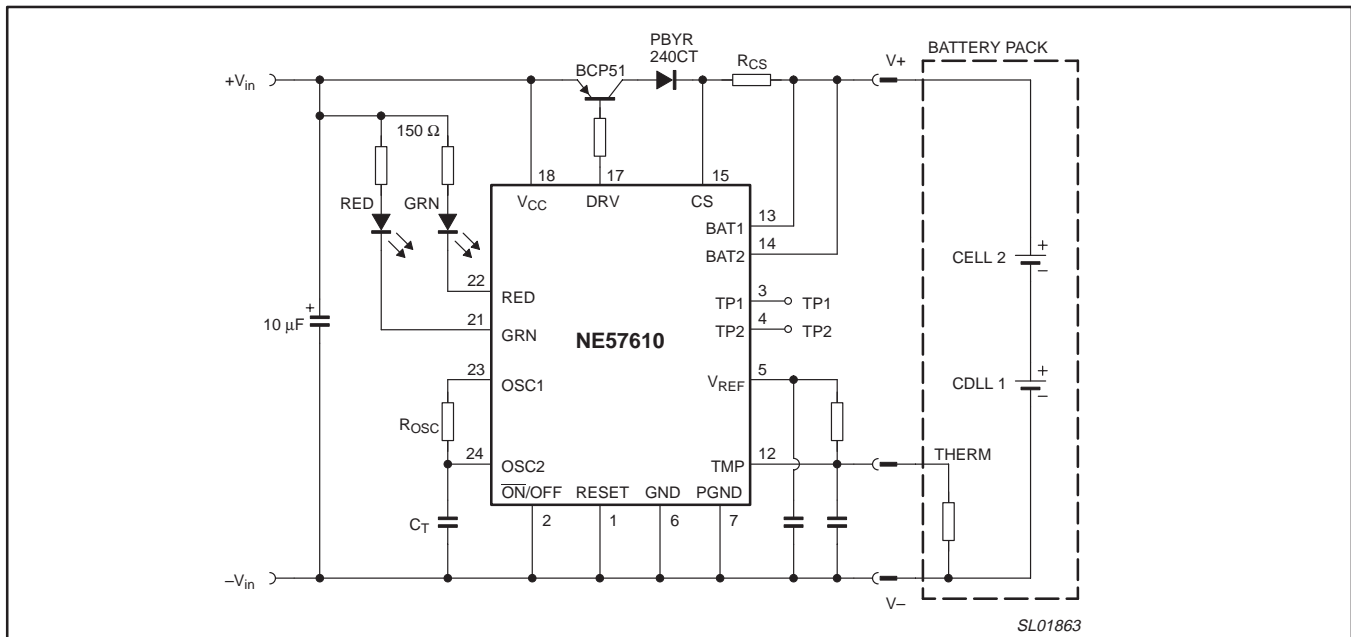

Figure 17. Typical application circuit (2-cell).

Li-ion battery charger control with adjustable thresholds

NE57610

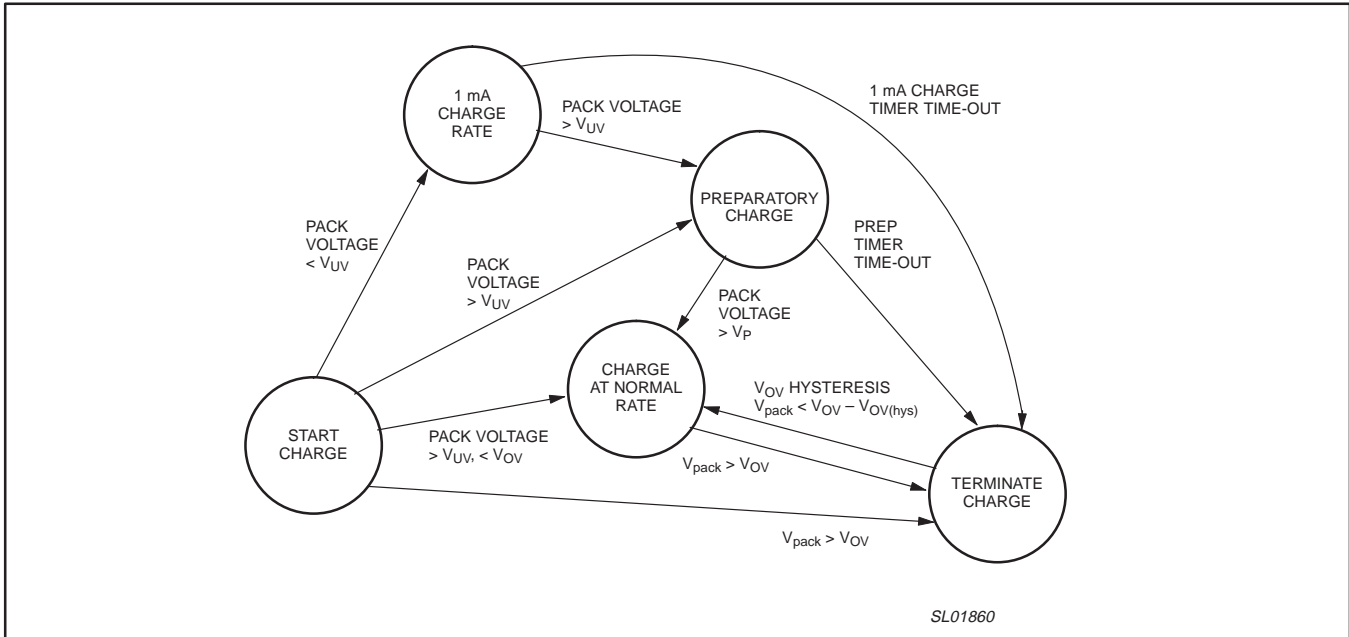

Figure 18. State diagram of charging process.

Charge-mode indicators

Determining which state the battery charger is operating is easily done by viewing the red and green LEDs which should be wired between pins 22 and 21, respectively, and the input voltage source. Each LED should have a 150 Ω resistor in series. Table 1 shows the states of these LEDs and the two test pins (TP1 (pin3) and TP2 (pin4)).

Table 1. Charge mode indicators versus charger activity

Condition	Pin 22 (Red)	Pin 21 (Green)	Pin 3 TP1	Pin 4 TP2
Reconditioning charge	Blink	OFF	Hi Low	Low
Preparatory charge	ON	OFF	Hi Low	Low
Normal charge	ON	OFF	Hi Low	Low
Charge done	OFF	Blink	Low	Hi Low
Charge timer time-out	Blink	OFF	Low	Low
Fault: $V_{OV}, V_{LV}, V_{LV}, V_{IN(min)}$	OFF	OFF	Low	Low

Programming the total charge timer

To set the total charge time, place a timing capacitor (C_T) between pin 24 and the ground pins (pins 6 and 7) and a resistor (R_{OSC}) between pins 23 and 24. The typical Li-ion cell requires 3 hours to totally recharge from V_{UV} and V_{OV} , so a charge period of greater than or equal to 3 hours should be allowed. The total charge time can be set by referring to Figure 19.

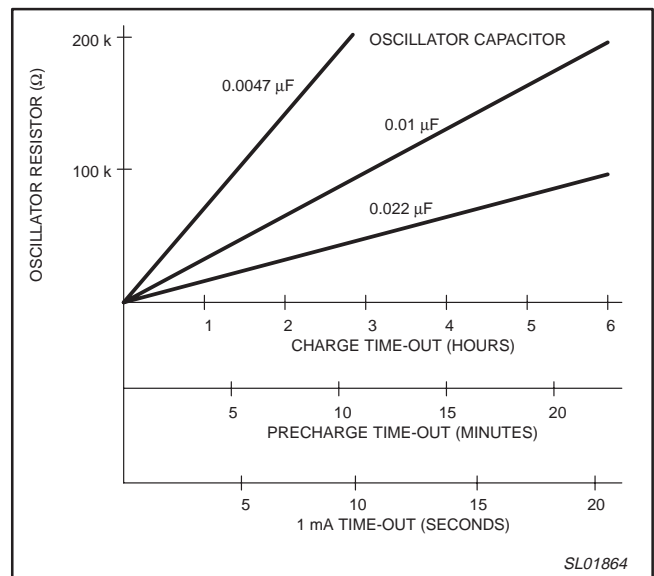

Figure 19. Total charge time versus C_T .

Li-ion battery charger control with adjustable thresholds

NE57610

Setting the charge currents and detection thresholds

The NE57610 has a preset charge termination voltage which is set during manufacture. The remaining charge currents and detection thresholds involved during the charging process must be set with the value of certain resistors and optionally by using the ADJ pins 1 through 4. Setting the thresholds is very important because the charge termination voltage alone is a state of overcharge for the lithium cell. If ignored, this can be very hazardous.

Figure 16 shows some of the terms and charging periods.

Setting the high-rate charge current

The second most important parameter is the adjustable high-rate charge current. First, determine the highest rate of charge of the chosen lithium cell from the cell's datasheet. This rate must not be exceeded because it would cause excessive heating of the cell during charging. The maximum charge rate will typically charge a completely discharged cell in under 3 hours.

Then, calculate the required value of the current sensing resistor (R_{CS}). This resistor also controls the rate of the other charge currents (pre-charge and reconditioning charge). All of these charge rates can be individually lowered by adding adjustment resistors to the ADJ1–ADJ4 pins. (See 'Using the ADJ1–ADJ4 pins'.)

The high-rate charging current is set by the value of R_{CS} and can be found by the following equation:

$$R_{CS} = \frac{0.22V}{I_{chg(high-rate)}} \quad \text{Eqn. (1)}$$

The typical value is around 0.3 Ω , which yields a 660 mA for the high-rate charge. If a current-limited wall transformer is used, this current may never be reached.

The pre-charge rate is set internally at around 1/8th of the high-rate of charge. This value may also be lowered by adding a resistor to V_{SS} from the ADJ3 pin. (See 'Using the ADJ1- ADJ4 pins'.)

Using the ADJ1–ADJ5 pins

Using the ADJ1–ADJ5 pins is optional. The NE57610 will operate as specified when the pins are left unconnected.

The ADJ pins are the center-node voltage of an internal resistor divider which are preset to the values given in the datasheet. Each of the parameters may be modified by placing an external resistor to ground or to V_{ref} . The ADJx voltages are directly related to the voltage measured across the current sense resistor (R_{CS}) between CS and the BAT1 & BAT2 pins.

The ADJ5 pin will increase the full-charge voltage (V_{OV}) by 15 mV if the pin is connected to ground.

ADJ1 through ADJ4 are ground-referenced voltages which can lower the preset values of the overcurrent cutoff (ADJ1), the top-off-charge minimum current threshold (ADJ2), the pre-charge charge current (ADJ3), and the high-rate charging current (ADJ4).

The overcurrent cutoff current is normally not used because there is usually a current-limited wall transformer providing the input power for the charger, and the transformer's current limit is usually within the safe range of the cell(s). This cutoff voltage can be lowered by lowering the ADJ1 voltage.

The equivalent circuits for the ADJ1–ADJ4 circuits are shown in Figure 20.

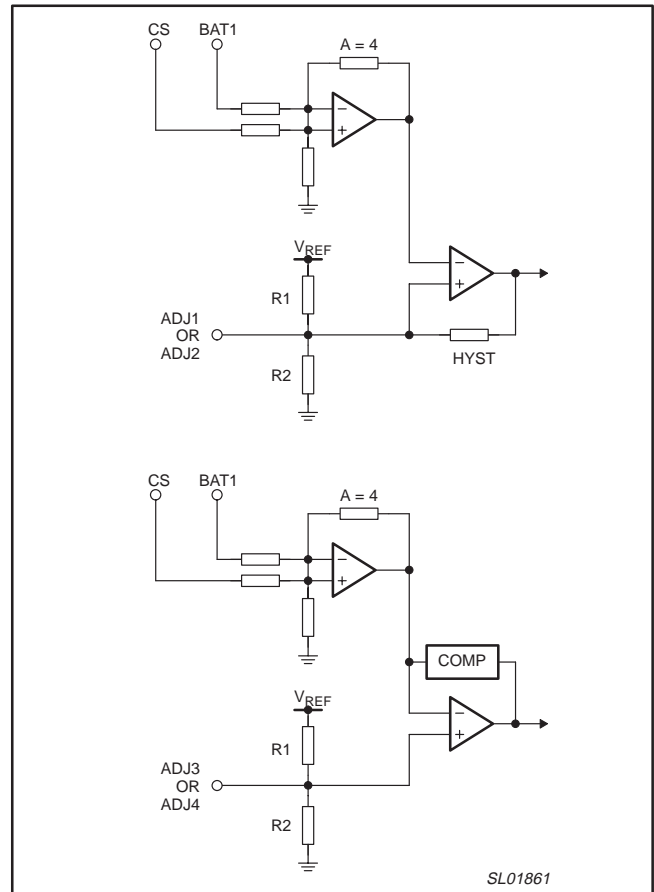

Figure 20. Equivalent circuits for ADJ1–ADJ4.

Table 2. ADJ1–ADJ4 internal resistor divider values

Pin name	Pin	Pin voltage	R1	R2	V_{OS}
ADJ1	8	1.16 V	5.8 k Ω	105 k Ω	–
ADJ2	9	62 mV	128 k Ω	10.5 k Ω	4.5 mV
ADJ3	10	120 mV	146 k Ω	16 Ω	3.1 mV
ADJ4	11	0.89 V	20 k Ω	58 Ω	–

The equation relating the values of ADJ pins to the voltage between the CS pin and the BAT1 and BAT2 pins is given by Equation (2):

$$V_{ADJx} = 4(I_x (R_{CS}) + V_{OS}) \quad \text{Eqn. (2)}$$

The V_{OS} term is the input offset voltage of the current-sense amplifier, which varies with the battery voltage. The offset term is only significant while low levels of current are being sensed, such as during the pre-charge period and the end-of-charge current threshold. During the high-rate charge and overcurrent conditions the contribution of the input offset voltage is negligible.

Li-ion battery charger control with adjustable thresholds

NE57610

Adjusting current levels with ADJ1–ADJ4

First, calculate the desired voltage of the ADJ pin in question. This is done by executing Equation (2), and using the value of the input offset voltage (V_{OS}) if applicable. It becomes a matter of solving a resistor divider problem with a parallel resistor on the lower branch. The equation becomes (referring to the resistor designators in Figure 16 and the values from Table 2):

$$R_{ext} = \frac{(V_{ADJx}(R1R2))}{(V_{REF} R2 - V_{ADJx} (R1 + R2))} \quad \text{Eqn. (3)}$$

where R_{ext} is the external resistor from the respective ADJ pin to V_{SS} .

DESIGNING THE POWER SECTION OF THE BATTERY CHARGER

There are several factors that are important to the design of a reliable Li-ion battery charger system. These major factors are:

- The input voltage must not fall below the cell voltage plus the headroom voltage of the charger circuit. The headroom voltage for the charger circuit is 1.6 V which would make the minimum input voltage about 5.6 V. This requirement also includes the troughs of any ripple voltage riding atop the DC input voltage from a poorly filtered wall transformer.
- The maximum input voltage must not exceed the voltage ratings of the components contained within the charging circuit.
- The power rating and the thermal design of the linear pass transistor must be able to withstand the maximum experienced headroom voltage at the high-rate charge current. The worst case condition can be calculated by assuming the cell is at its lowest typical voltage (2.9 V) and the input voltage is at its highest point in its range (typically the DC voltage created at the highest AC input) times the high-rate charge current. The power can then be calculated by Equation (4):

$$P_{D(max)} = (V_{in(max)} - V_{cell(min)}) \times (I_{charge}) \quad \text{Eqn. (4)}$$

The criteria for the selection of the PNP power transistor should be:

- $V_{CEO} > 1.5 V_{in(max)}$
- $I_C > 1.5 I_{charge}$
- $h_{FE} > 50 @ 1 \text{ Amp}$
- $P_D > P_{D(max)}$

The choice of power transistor package should be done with the highest possible power dissipation and at the highest expected ambient temperature. Choose a surface mount package by referring to Figure 21 and drawing two intersecting lines from the appropriate points on the X and Y axis.

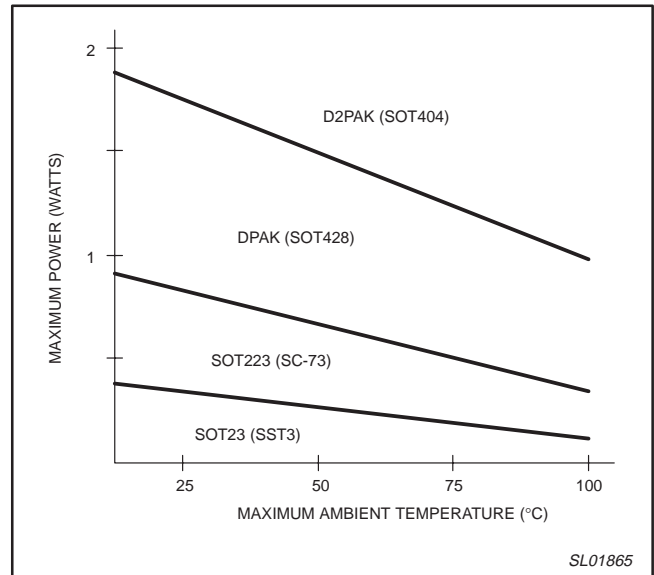

Figure 21. Maximum power dissipation versus ambient temperature versus package.

This chart gives the package to use the minimum recommended pad size is used under the power part. Making the pad size larger can increase the power handling capacity of the part without sacrificing its reliability. Table 3 shows how to dissipate more power in a smaller package.

Table 3.

Pad size	$R_{th(j-a)}$	Power increase
2X	0.88 °C/W	14%
3X	0.80 °C/W	25%
4X	0.74 °C/W	35%
5X	0.70 °C/W	43%

NOTES:

1. Going beyond five times the minimum recommended footprint yields diminishing improvements to the thermal performance.
2. Given for an F4 fiberglass PCB with 2 oz. copper

Li-ion battery charger control with adjustable thresholds

NE57610

DESIGN-RELATED SAFETY ISSUES

In designing charging circuits for lithium-ion and polymer cells, the designer should provide for user mishandling, common environmental hazards and for random component failures.

Some of the user-related issues are: plugging the battery pack into the charger backwards, inserting of the battery into the live charger, and plugging the charger into an unexpected input voltage source. A series diode is typically used for reversed battery protection. This prevents reverse currents from flowing into the device, protecting the functionality of the charger. Protecting against live insertion of the battery and the wrong type of input power to the charger must be

dealt with by examining how the circuit powers-up and making sure there are no power-up sequences that can lead to a component failure or hazardous operating conditions.

A common adverse operating condition at the input is lightning-caused transients. A simple 500 mW zener diode across the input terminals handles positive and negative transients caused by lightning. The zener will fail short-circuited, if the energy exceeds its surge energy ratings. To help protect the protection zener, place a small inductor or low value resistor in series from the input source. This will lower the peak voltage and energy entering the zener diode and will distribute the energy over a longer period.

PACKING METHOD

The NE57610 is packed in reels, as shown in Figure 22.

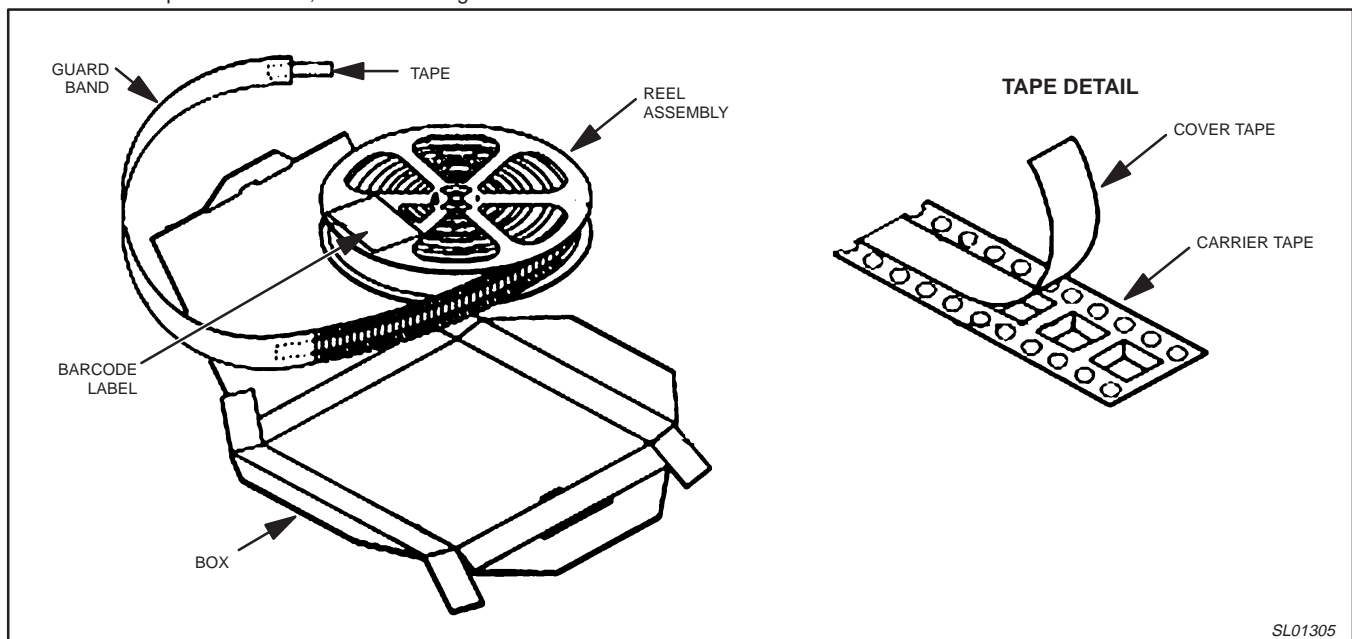
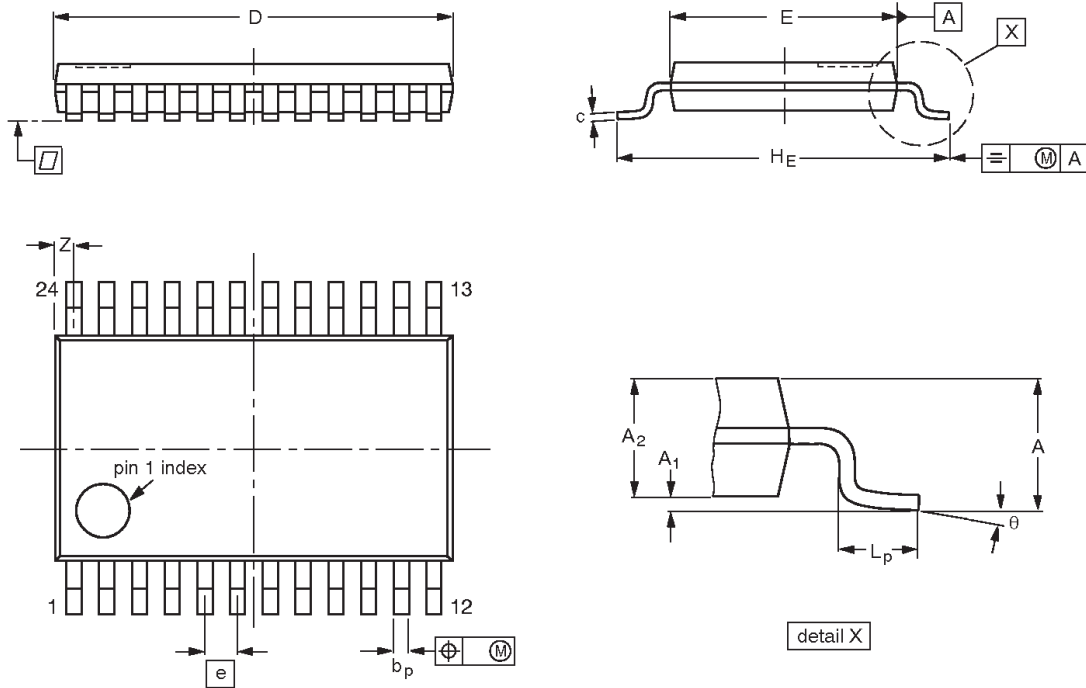

Figure 22. Tape and reel packing method

Li-ion battery charger control with adjustable thresholds

NE57610

TSOP-24: plastic thin shrink small outline package; 24 leads; body width 4.4 mm



DIMENSIONS (mm are the original dimensions)

UNIT	A max.	A ₁	A ₂	b _p	c	D ⁽¹⁾	E ⁽²⁾	e	H _E	L _p	Z ⁽¹⁾	θ
mm	1.10	0.15 0.05	0.95 0.80	0.2 0.1	0.25 0.1	6.8 6.37	4.5 4.3	0.5	6.7 6.1	0.75 0.50	0.8 0.2	10° 0°

Notes

1. Plastic or metal protrusions of 0.15 mm maximum per side are not included.
2. Plastic interlead protrusions of 0.25 mm maximum per side are not included.

OUTLINE VERSION	REFERENCES				EUROPEAN PROJECTION	ISSUE DATE
	IEC	JEDEC	EIAJ			

Li-ion battery charger control with adjustable thresholds

NE57610

REVISION HISTORY

Rev	Date	Description
_1	20021105	Product data; initial version. Engineering Change Notice 853–2351 28505 (date: 20020620).

Data sheet status

Level	Data sheet status ^[1]	Product status ^{[2] [3]}	Definitions
I	Objective data	Development	This data sheet contains data from the objective specification for product development. Philips Semiconductors reserves the right to change the specification in any manner without notice.
II	Preliminary data	Qualification	This data sheet contains data from the preliminary specification. Supplementary data will be published at a later date. Philips Semiconductors reserves the right to change the specification without notice, in order to improve the design and supply the best possible product.
III	Product data	Production	This data sheet contains data from the product specification. Philips Semiconductors reserves the right to make changes at any time in order to improve the design, manufacturing and supply. Relevant changes will be communicated via a Customer Product/Process Change Notification (CPCN).

[1] Please consult the most recently issued data sheet before initiating or completing a design.

[2] The product status of the device(s) described in this data sheet may have changed since this data sheet was published. The latest information is available on the Internet at URL <http://www.semiconductors.philips.com>.

[3] For data sheets describing multiple type numbers, the highest-level product status determines the data sheet status.

Definitions

Short-form specification — The data in a short-form specification is extracted from a full data sheet with the same type number and title. For detailed information see the relevant data sheet or data handbook.

Limiting values definition — Limiting values given are in accordance with the Absolute Maximum Rating System (IEC 60134). Stress above one or more of the limiting values may cause permanent damage to the device. These are stress ratings only and operation of the device at these or at any other conditions above those given in the Characteristics sections of the specification is not implied. Exposure to limiting values for extended periods may affect device reliability.

Application information — Applications that are described herein for any of these products are for illustrative purposes only. Philips Semiconductors make no representation or warranty that such applications will be suitable for the specified use without further testing or modification.

Disclaimers

Life support — These products are not designed for use in life support appliances, devices, or systems where malfunction of these products can reasonably be expected to result in personal injury. Philips Semiconductors customers using or selling these products for use in such applications do so at their own risk and agree to fully indemnify Philips Semiconductors for any damages resulting from such application.

Right to make changes — Philips Semiconductors reserves the right to make changes in the products—including circuits, standard cells, and/or software—described or contained herein in order to improve design and/or performance. When the product is in full production (status 'Production'), relevant changes will be communicated via a Customer Product/Process Change Notification (CPCN). Philips Semiconductors assumes no responsibility or liability for the use of any of these products, conveys no license or title under any patent, copyright, or mask work right to these products, and makes no representations or warranties that these products are free from patent, copyright, or mask work right infringement, unless otherwise specified.

Contact information

For additional information please visit
<http://www.semiconductors.philips.com>. Fax: +31 40 27 24825

© Koninklijke Philips Electronics N.V. 2002
All rights reserved. Printed in U.S.A.

Date of release: 11-02

For sales offices addresses send e-mail to:
sales.addresses@www.semiconductors.philips.com

Document order number:

9397 750 10465

Let's make things better.