



SAE 8055 - I²RF™ 2.4 GHz Wireless Transceiver with 64KByte RAM

The SAE 8055 is a single-chip full duplex multichannel transceiver system for the 2.4 GHz ISM band. This device combines outstanding RF performance with the flexibility of digital circuits. A 64KBytes internal RAM code memory allows easy software development and fast code download from external memory devices.

A low standby current and an efficient power amplifier make the SAE 8055 ideal for battery-powered applications.

With just one chip and a 12 MHz crystal you can cover the 2.4 GHz ISM band, lowering your logistics and production costs. Benefit from design speed and flexibility by using the high-performance one-chip solution for your application. The internal 64KBytes code RAM space will offer an unlimited software flexibility.

Features

- 2.4 GHz ISM band full duplex transceiver supporting Frequency Hopping Spread Spectrum and Adaptive Frequency Hopping
- 8-bit microcontroller
- Code memory selectable (64KBytes) ROM or RAM
- Data RAM memory (8KBytes)
- Voice Codec supporting G.726 for decoder
- 2 x G.726 for encoder and 1 x G.726 for decoder
- USB2.0 full speed device interface
- 3-wire SPI Master Interface with 2 CS and up to 12 MHz speed
- 6 dedicated analog to digital converters (ADC)
- 6 configurable general purpose inputs (analog or digital)
- 14 dedicated general purpose digital input/outputs (GPIO)
- H-bridge circuitry with integrated drive capability for one bidirectional DC motor or two unidirectional DC motors
- I²C controller supporting 100kHz/400kHz data rate (master mode)
- 2 general purpose 16-bit timers and a watch dog timer
- 1 UART supporting 9600/19200/38400/115200 baud rates
- 1 ISO7816 compliant interface (asynchronous mode)
- Debug interface for firmware development (JTAG)
- Integrated power management including battery charging control
- Supply voltage range 2.0..3.6 V
- Operating temperature range -25..+85°C
- TQFP-100 green package

www.infineon.com/i2rf

Key Benefits & Applications

Key Benefits

- Single chip with integrated RF
- Adaptive Frequency Hopping (AFH) and Frequency Hopping Spread Spectrum (FHSS) for interference-robust communication
- Excellent RF parameters: up to 15 m range
- Only one crystal needed for the complete system
- Different RAM/ROM configurations cover all customer requirements like 64KB ROM or 32/32 RAM/ROM or 64KB RAM code execution
- User-friendly software, documentation and evaluation boards

Applications

- Easy cable replacement for many applications
- Industrial monitoring and control
- Wireless alarm and security systems
- Automatic meter reading
- Home automation
- Secure remote keyless entry
- Barcode reading
- Point-of-Sales systems
- Software development platform

SAE 8055 - I²RFTTM

2.4 GHz Wireless Transceiver with 64KByte RAM

Block Diagram

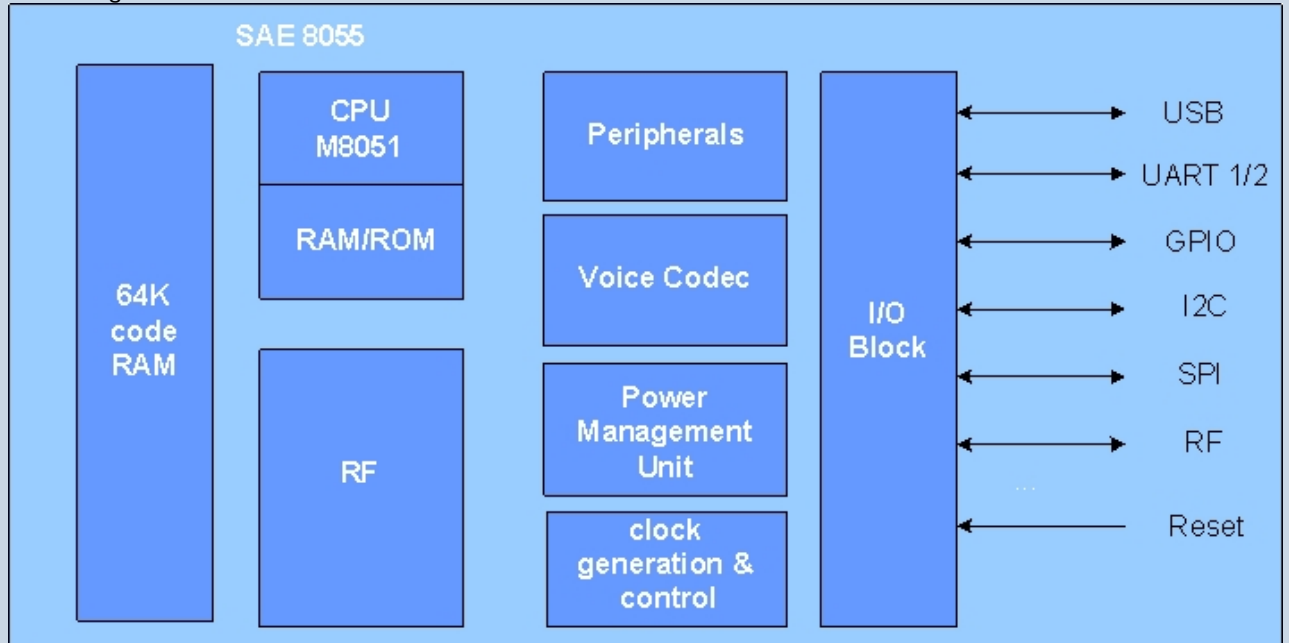

Application Block Diagram

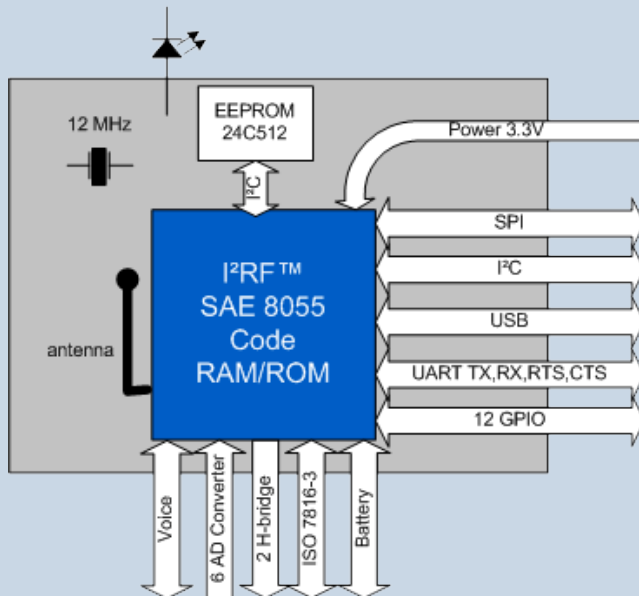

Published by
Infineon Technologies AG
85579 Neubiberg, Germany

© 2010 Infineon Technologies AG.
All Rights Reserved.

Visit us:
www.infineon.com

Order Number: B139-H9508-X-X-7600
Date: 07 / 2010

ATTENTION PLEASE!

The information given in this document shall in no event be regarded as a guarantee of conditions or characteristics ("Beschaffheitsgarantie"). With respect to any examples or hints given herein, any typical values stated herein and/or any information regarding the application of the device, Infineon Technologies hereby disclaims any and all warranties and liabilities of any kind, including without limitation warranties of non-infringement of intellectual property rights of any third party.

INFORMATION

For further information on technology, delivery terms and conditions and prices please contact your nearest Infineon Technologies Office (www.infineon.com).

WARNINGS

Due to technical requirements components may contain dangerous substances. For information on the types in question please contact your nearest Infineon Technologies Office. Infineon Technologies Components may only be used in life-support devices or systems with the express written approval of Infineon Technologies, if a failure of such components can reasonably be expected to cause the failure of that life-support device or system, or to affect the safety or effectiveness of that device or system. Life support devices or systems are intended to be implanted in the human body, or to support and/or maintain and sustain and/or protect human life. If they fail, it is reasonable to assume that the health of the user or other persons may be endangered.