

CLC426

Wideband, Low-Noise, Voltage Feedback Op Amp

General Description

The CLC426 combines an enhanced voltage-feedback architecture with an advanced complementary bipolar process to provide a high-speed op amp with very low noise (1.6nV/√Hz & 2.0pA/√Hz) and distortion (-62/-68dBc 2nd/3rd harmonics at 1V_{pp} and 10MHz).

Providing a wide 230MHz gain-bandwidth product, a fast 400V/μs slew rate and very quick 16ns settling time to 0.05% , the CLC426 is the ideal choice for high speed applications requiring a very wide-dynamic range such as an input buffer for high-resolution analog-to-digital converters.

The CLC426 is internally compensated for gains ≥ 2V/V and can easily be externally compensated for unity-gain stability in applications such as wideband low-noise integrators. The CLC426 is also equipped with external supply current adjustment which allows the user to optimize power, bandwidth, noise and distortion performance for each application.

The CLC426's combination of speed, low noise and distortion and low dc errors will allow high-speed signal conditioning applications to achieve the highest signal-to-noise performance. To reduce design times and assist board layout, the CLC426 is supported by an evaluation board and SPICE simulation model available from National.

For even higher gain-bandwidth voltage-feedback op amps see the 1.9GHz CLC425 (A_v ≥ 10V/V) or the 5.0GHz CLC422 (A_v ≥ 30V/V).

Features

- Wide gain-bandwidth product: 230MHz
- Ultra-low input voltage noise: 1.6nV/√Hz
- Very low harmonic distortion: -62/-68dBc
- Fast slew rate: 400V/μs
- Adjustable supply current
- Dual ±2.5 to ±5V or single 5 to 12V supplies
- Externally compensatable

Applications

- Active filters & integrators
- Ultrasound
- Low-power portable video
- ADC/DAC buffer
- Wide dynamic range amp
- Differential amps
- Pulse/RF amp

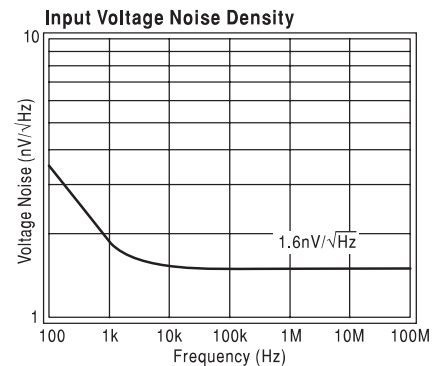

Typical Application

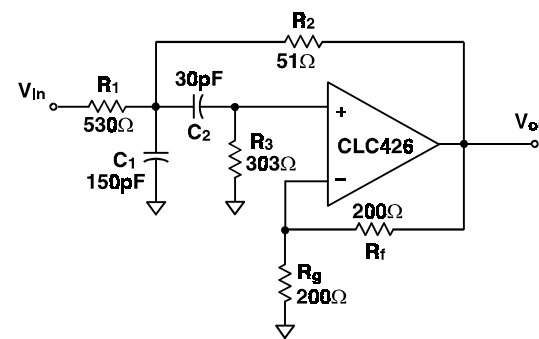

**Wide Dynamic Range
Sallen-Key Band Pass Filter
2nd-Order
(20MHz, Q=10, G=2)**

Frequency Response

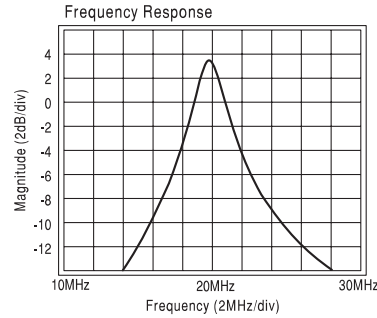

Pinout DIP & SOIC

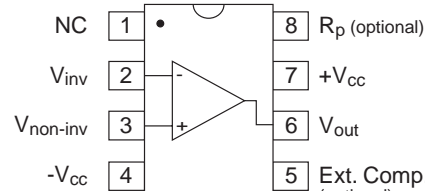

CLC426 Electrical Characteristics ($V_{CC} = \pm 5V$; $A_V = +2V/V$; $R_f = 100\Omega$; $R_L = 100\Omega$; unless noted)

PARAMETERS	CONDITIONS	TYP	MIN/MAX RATINGS				UNITS	NOTES
			+25°C	+25°C	0 to +70°C	-40 to +85°C		
Ambient Temperature	CLC426	+25°C	+25°C	0 to +70°C	-40 to +85°C			
FREQUENCY DOMAIN RESPONSE								
gain bandwidth product	$V_{out} < 0.5V_{pp}$	230	170	120	100	MHz	1	
-3dB bandwidth, $A_V = +2$	$V_{out} < 0.5V_{pp}$	130	90	70	55	MHz		
	$V_{out} < 5.0V_{pp}$	50	25	22	20	MHz		
gain flatness	$V_{out} < 0.5V_{pp}$							
peaking	DC to 200MHz	0.6	1.5	2.2	2.5	dB		
rolloff	DC to 30MHz	0.0	0.6	1.0	1.0	dB		
linear phase deviation	DC to 30MHz	0.2	1.0	1.5	1.5	°		
TIME DOMAIN RESPONSE								
rise and fall time	1V step	2.3	3.5	5.0	6.5	ns		
settling time	2V step to 0.05%	16	20	24	24	ns		
overshoot	1V step	5	15	15	18	%		
slew rate	5V step	400	300	275	250	V/ μ s		
DISTORTION AND NOISE RESPONSE								
2 nd harmonic distortion	1V _{pp} , 10MHz	-62	-52	-47	-45	dBc		
3 rd harmonic distortion	1V _{pp} , 10MHz	-68	-58	-54	-54	dBc		
equivalent input noise	op amp only							
voltage	1MHz to 100MHz	1.6	2.0	2.3	2.6	nV/ \sqrt Hz		
current	1MHz to 100MHz	2.0	3.0	3.6	4.6	pA/ \sqrt Hz		
STATIC DC PERFORMANCE								
open-loop gain	DC	64	60	54	54	dB		
input offset voltage		1.0	2.0	2.8	2.8	mV	A	
average drift		3	---	10	10	μ V/°C		
input bias current		5	25	40	65	μ A	A	
average drift		90	---	600	700	nA/°C		
input offset current		0.3	3	5	5	μ A	A	
average drift		5	---	25	50	nA/°C		
power-supply rejection ratio	DC	73	65	60	60	dB		
common-mode rejection ratio	DC	70	62	57	57	dB		
supply current	pin #8 open, $R_L = \infty$	11	12	13	15	mA	A	
MISCELLANEOUS PERFORMANCE								
input resistance	common-mode	500	250	125	125	k Ω		
	differential-mode	750	200	50	25	k Ω		
input capacitance	common-mode	2.0	3.0	3.0	3.0	pF		
	differential-mode	2.0	3.0	3.0	3.0	pF		
output resistance	closed loop	0.07	0.1	0.2	0.2	Ω		
output voltage range	$R_L = \infty$	± 3.8	± 3.5	± 3.3	± 3.3	V		
	$R_L = 100\Omega$	± 3.5	± 3.2	± 2.6	± 1.3	V		
input voltage range	common mode	± 3.7	± 3.5	± 3.3	± 3.3	V		
output current		± 70	± 50	± 40	+35, -20	mA		

Min/max ratings are based on product characterization and simulation. Individual parameters are tested as noted. Outgoing quality levels are determined from tested parameters.

Absolute Maximum Ratings

supply voltage	$\pm 7V$
short circuit current	(note 2)
common-mode input voltage	$\pm V_{CC}$
differential input voltage	$\pm 10V$
maximum junction temperature	+150°C
storage temperature	-65°C to +150°C
lead temperature (soldering 10 sec)	+300°C
ESD rating	2000V

Notes

- A) J-level: spec is 100% tested at +25°C.
 1) Minimum stable gain with out external compensation is +2 or -1V/V, the CLC426 is unity-gain stable with external compensation.
 2) Output is short circuit protected to ground, however maximum reliability is obtained if output current does not exceed 160mA.
 3) See text for compensation techniques.

Ordering Information

Model	Temperature Range	Description
CLC426AJP	-40°C to +85°C	8-pin PDIP
CLC426AJE	-40°C to +85°C	8-pin SOIC
CLC426A8B	-55°C to +125°C	8-pin CerDIP, MIL-STD-883

Package Thermal Resistance

Package	θ_{JC}	θ_{JA}
Plastic (AJP)	70°C/W	125°C/W
Surface Mount (AJE)	60°C/W	140°C/W
CerDIP	40°C/W	130°C/W

Reliability Information

Transistor Count	52
------------------	----

CLC426 Typical Performance ($T_A=25^\circ\text{C}$, $\pm V_{CC}=\pm 5\text{V}$, $A_V=+2$, $R_f=100\Omega$, $R_L=100\Omega$, unless noted)

Non-Inverting Frequency Response

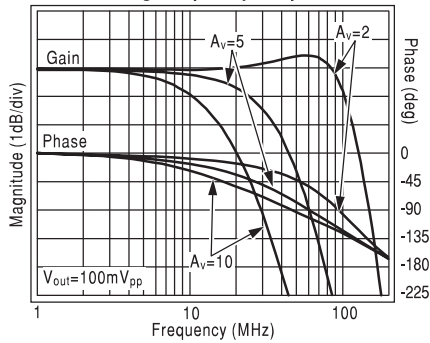

Inverting Frequency Response

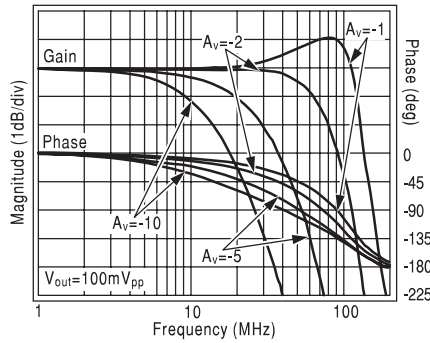

Frequency Response vs. Load Resistance

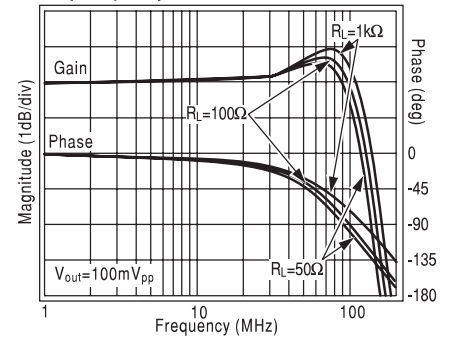

Open-Loop Gain vs. Supply Current

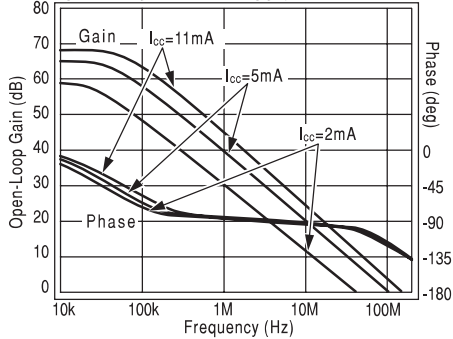

Open-Loop Gain vs. Compensation Cap.

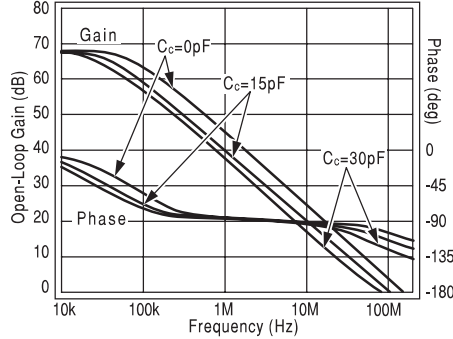

Frequency Response vs. Compensation Cap.

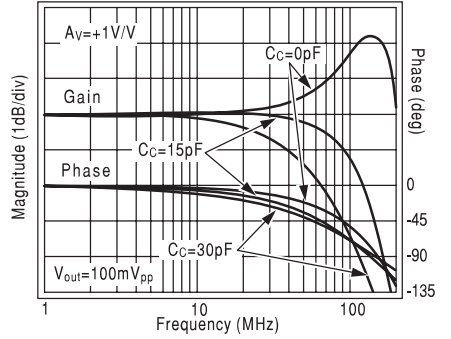

Supply Current vs. Rp

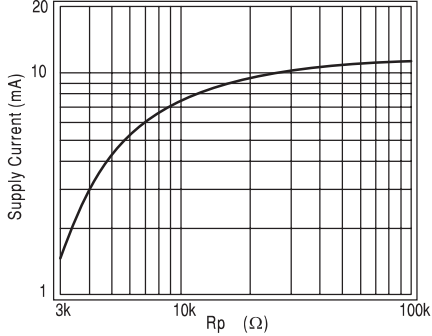

Voltage Noise vs. Supply Current

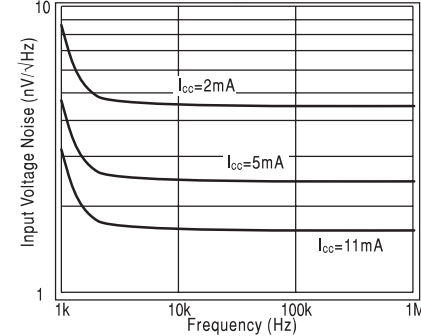

Frequency Response vs. Output Amplitude

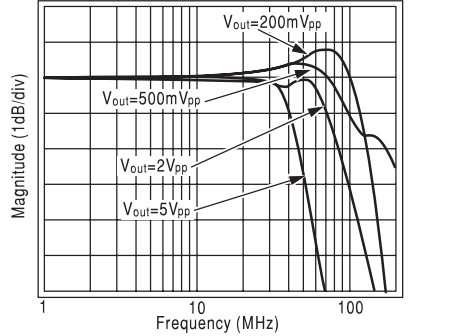

Gain-Bandwidth Product vs Supply Current

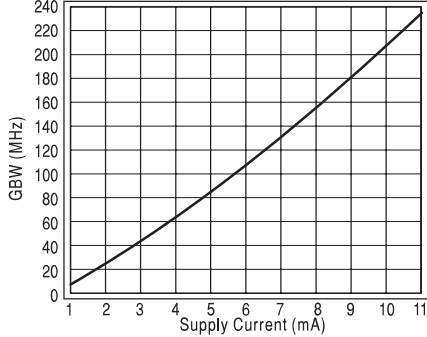

Current Noise vs. Supply Current

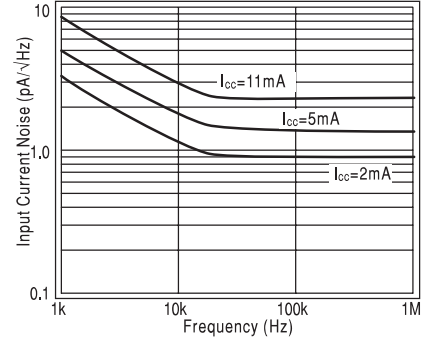

Maximum Output Voltage vs. Load

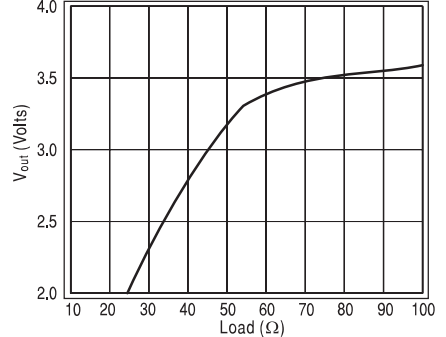

CMRR and PSRR

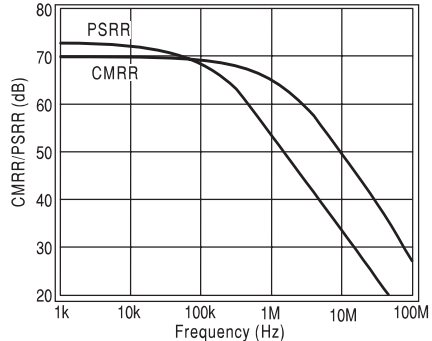

Closed-Loop Output Resistance

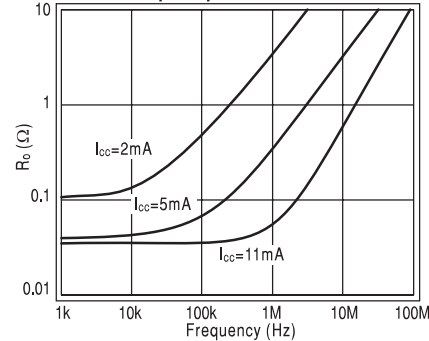

Typical DC Errors vs. Temperature

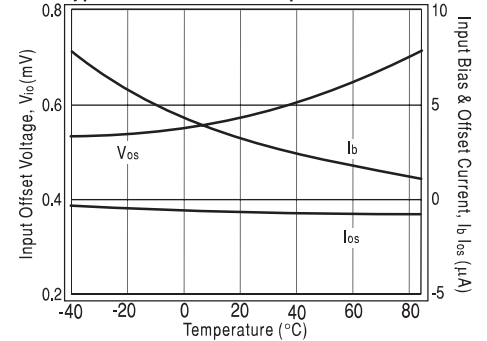

CLC426 Typical Performance ($T_A=25^\circ\text{C}$, $\pm V_{CC}=\pm 5\text{V}$, $A_V=+2$, $R_f=100\Omega$, $R_L=100\Omega$, unless noted)

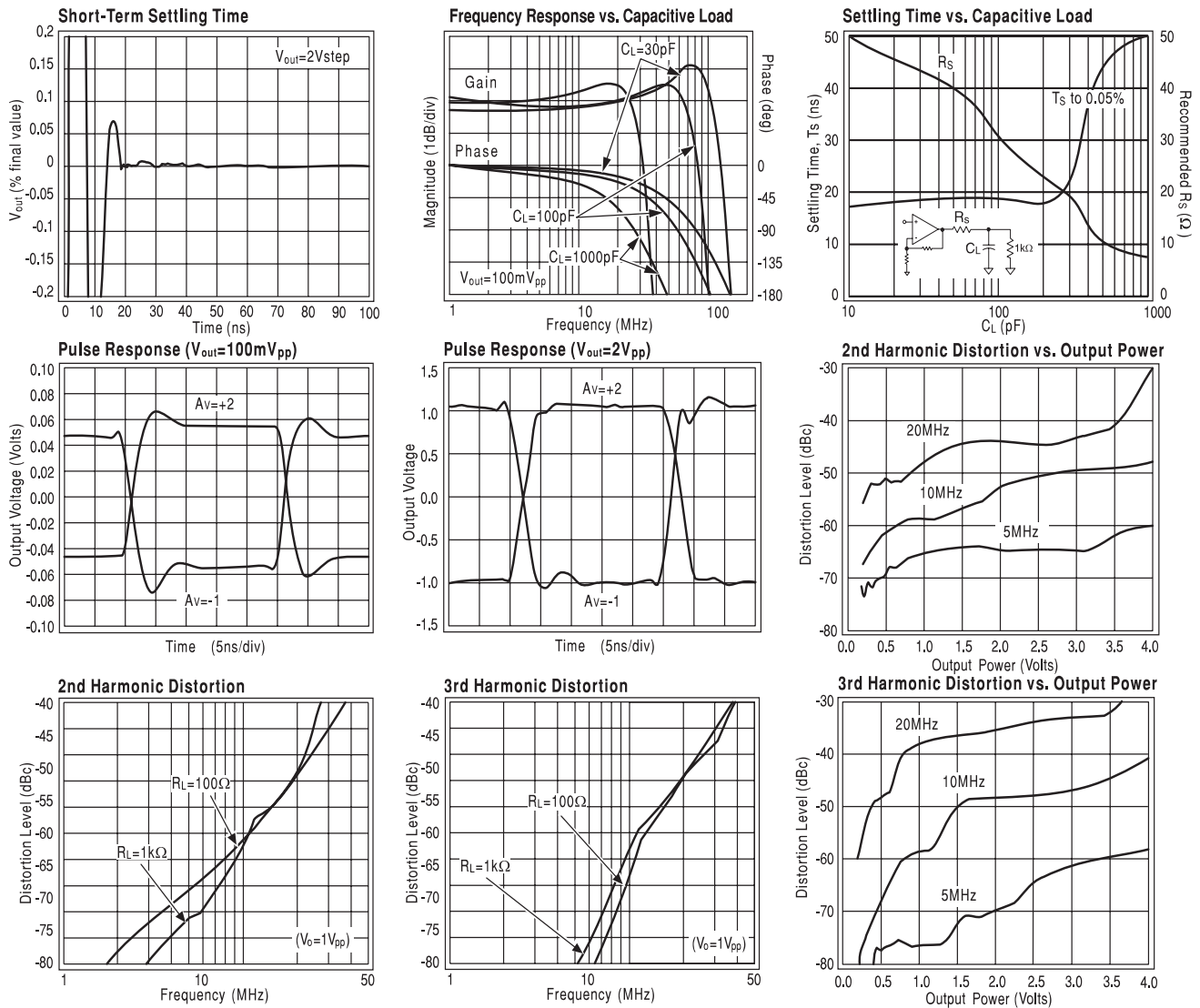

Application Discussion

Introduction

The CLC426 is a wide bandwidth voltage-feedback operational amplifier that is optimized for applications requiring wide dynamic range. The CLC426 features adjustable supply current and external compensation for the added flexibility of tuning its performance for demanding applications. The Typical Performance section illustrates many of the performance trade-offs. Although designed to operate from $\pm 5\text{V}$ power supplies, the CLC426 is equally impressive operating from a single $+5\text{V}$ supply. The following discussion will enable the proper selection of external components for optimum device performance in a variety of applications.

External Compensation

The CLC426 is stable for noise gains $\geq 2\text{V/V}$. For unity-gain operation, the CLC426 requires an external compensation capacitor (from pin 5 to ground). The plot located in the Typical Performance section labeled "Frequency Response vs Compensation Cap." illustrates the CLC426's typical AC response for different values of compensation capacitor. From the plot it is seen that a value of 15pF

produces the optimal response of the CLC426 at unity gain. The plot labeled "Open-Loop Gain vs. Compensation Cap." illustrates the CLC426's open-loop behavior for various values of compensation capacitor. This plot also illustrates one technique of bandlimiting the device by reducing the open-loop gain resulting in lower closed-loop bandwidth. Fig. 1 shows the effect of external compensation on the CLC426's pulse response.

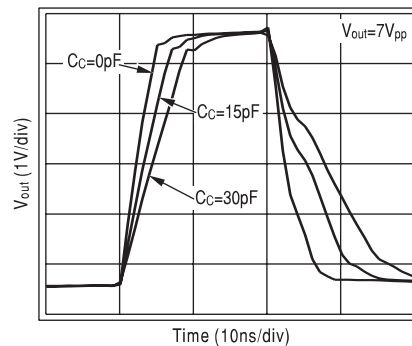

Fig. 1

Supply Current Adjustment

The CLC426's supply current can be externally adjusted downward from its nominal value to less than 2mA by adding an optional resistor (R_p) between pin 8 and the negative supply as shown in fig 2. The plot labeled "Open-Loop Gain vs. Supply Current" illustrates the influence that supply current has over the CLC426's open-loop

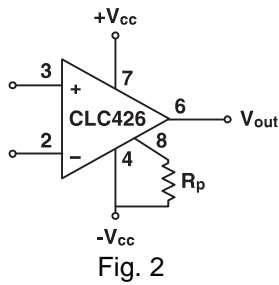

Fig. 2

response. From the plot it is seen that the CLC426 can be compensated for unity-gain stability by simply lowering its supply current. Therefore lowering the CLC426's supply current effectively reduces its open-loop gain to the point that there is adequate phase margin at unity gain crossover. The plot labeled "Supply Current vs. R_p " provides the means for selecting the value of R_p that produces the desired supply current. The curve in the plot represents nominal processing but a $\pm 12\%$ deviation over process can be expected. The two plots labeled "Voltage Noise vs. Supply Current" and "Current Noise vs. Supply Current" illustrate the CLC426 supply current's effect over its input-referred noise characteristics.

Driving Capacitive Loads

The CLC426 is designed to drive capacitive loads with the addition of a small series resistor placed between the output and the load as seen in fig. 3. Two plots located in

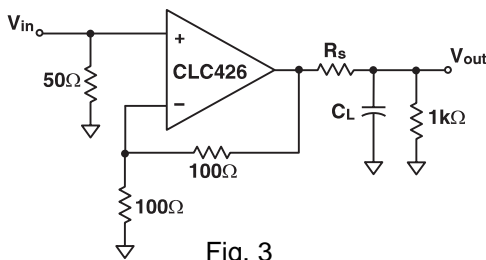

Fig. 3

the Typical Performance section illustrate this technique for both frequency domain and time domain applications. The plot labeled "Frequency Response vs. Capacitive Load" shows the CLC426's resulting AC response to various capacitive loads. The values of R_s in this plot were chosen to maximize the CLC426's AC response (limited to ≤ 1 dB peaking).

The second plot labeled "Settling Time vs. Capacitive Load" provides the means for the selection of the value of R_s which minimizes the CLC426's settling time. As seen from the plot, for a given capacitive load R_s is chosen from the curve labeled " R_s ". The resulting settling time to 0.05% can then be estimated from the curve labeled " T_s to 0.05%". The plot of fig. 4 shows the CLC426's pulse response for various capacitive loads where R_s has been chosen from the plot labeled "Settling Time vs. Capaci-

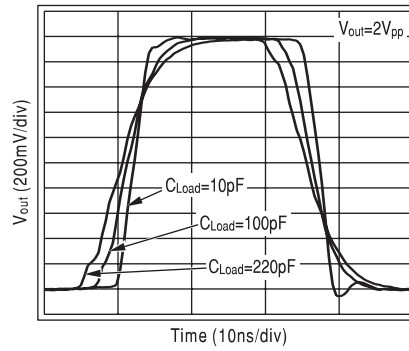

Fig. 4

tive Load".

Faster Settling

The circuit of fig. 5 shows an alternative method for driving capacitive loads that results in quicker settling times. The small series-resistor, R_s , is used to decouple the CLC426's open-loop output resistance, R_{out} , from the load capacitance. The small feedback-capacitance, C_f , is used to

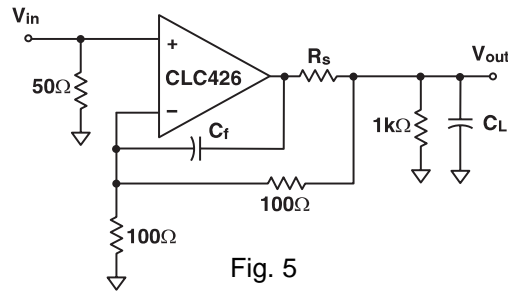

Fig. 5

provide a high-frequency bypass between the output and inverting input. The phase lead introduced by C_f compensates for the phase lag due to C_L and therefore restores stability. The following equations provide values of R_s and C_f for a given load capacitance and closed-loop amplifier gain.

$$R_s = R_{out} \left(\frac{R_f}{R_g} \right); \text{ where } R_{out} \approx 6\Omega \quad \text{Eq. 1}$$

$$C_f = \left(1 + \left(\frac{R_f}{R_g} \right) \right)^2 C_L \left(\frac{R_{out}}{R_g} \right) \quad \text{Eq. 2}$$

The plot in fig. 6 shows the result of the two methods of capacitive load driving mentioned above while driving a 100pF||1k load.

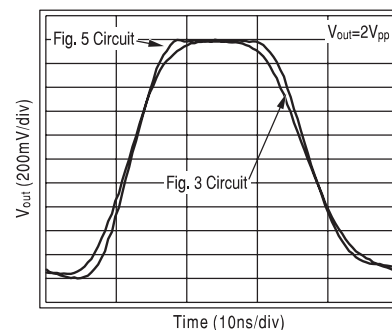

Fig. 6

Single-Supply Operation

The CLC426 can be operated with single power supply as shown in fig. 7. Both the input and output are capacitively

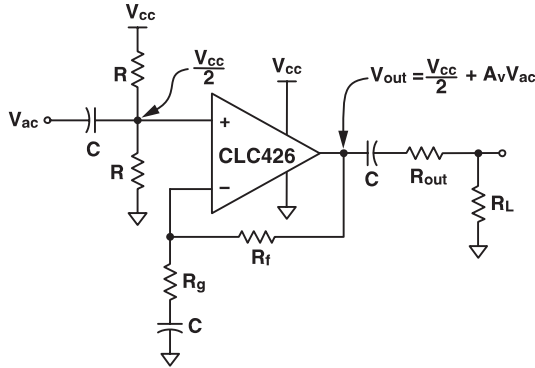

Fig. 7

coupled to set the dc operating point.

DAC Output Buffer

The CLC426's quick settling, wide bandwidth and low differential input capacitance combine to form an excellent I-to-V converter for current-output DACs in such applications as reconstruction video. The circuit of fig. 8 implements a low-noise transimpedance amplifier commonly used to buffer high-speed current output devices. The transimpedance gain is set by R_f . A feedback capacitor, C_f , is needed in order to compensate for the

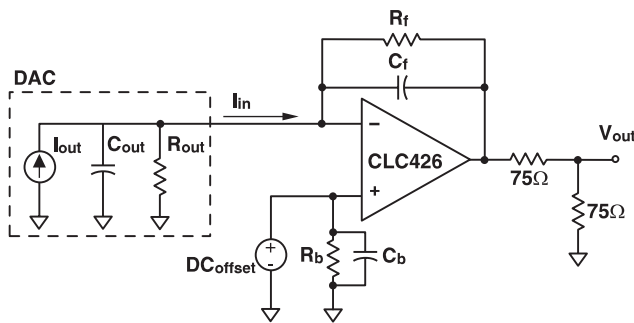

Fig. 8

inductive behavior of the closed-loop frequency response of this type of circuit. Equation 3 shows a means of calculating the value of C_f which will provide conditions for a maximally-flat signal frequency response with approximately 65° phase margin and 5% step-response overshoot. Notice that C_t is the sum of the DAC output capacitance and the differential input capacitance of the CLC426 which is located in its Electrical Characteristics Table. Notice also that CLC426's gain-bandwidth product (GBW) is also located in the same table. Equation 5 provides the resulting signal bandwidth.

$$C_f = 2 \sqrt{\frac{C_t}{2\pi R_f \text{GBW}}} \quad \text{Eq. 3}$$

$$C_t = C_{\text{out}} + C_{\text{in dif}} \quad \text{Eq. 4}$$

$$\text{signal bandwidth} = \frac{1}{2} \sqrt{\frac{\text{GBW}}{2\pi R_f C_t}} \quad \text{Eq. 5}$$

Sallen-Key Active Filters

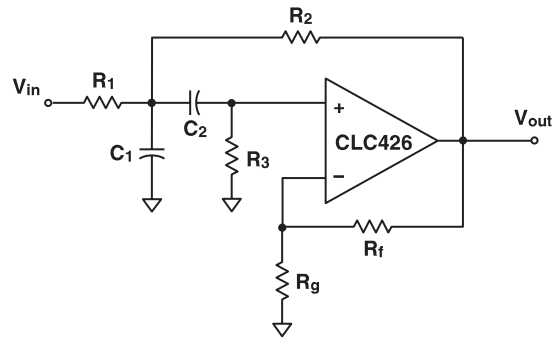

$$C_2 = \frac{1}{5} C_1$$

$$G = 1 + \frac{R_f}{R_g}, \text{ desired mid-band gain}$$

$$R_1 = 2 \frac{Q}{\text{GC}_1(2\pi f)}, \text{ where } f = \text{desired center frequency}$$

$$R_2 = \frac{\text{GR}_1 \left(\sqrt{1 + 4.8Q^2 - 2G + G^2 + 1} \right)}{4.8Q^2 - 2G + G^2}$$

$$R_3 = \frac{5\text{GR}_1 \left(\sqrt{1 + 4.8Q^2 - 2G + G^2 + G - 1} \right)}{4Q^2}$$

The CLC426 is well suited for Sallen-Key type of active filters. Fig. 9 shows the 2nd order Sallen-Key band-pass filter topology and design equations.

Fig. 9

To design the band-pass, begin by choosing values for R_f and R_g , for example $R_f = R_g = 200\Omega$. Then choose reasonable values for C_1 and C_2 (where $C_1 = 5C_2$) and then compute R_1 . R_2 and R_3 can then be computed. For optimum high-frequency performance it is recommended that the resistor values fall in the range of 10Ω to $1\text{k}\Omega$ and the capacitors be kept above 10pF . The design can be further improved by compensating for the delay through the op amp. For further details on this technique, please request Application Note OA-21 from National Semiconductor Corporation.

Printed Circuit Board Layout

Generally, a good high-frequency layout will keep power supply and ground traces away from the inverting input and output pins. Parasitic capacitances on these nodes to ground will cause frequency-response peaking and possible circuit oscillation, see OA-15 for more information. National suggests the CLC730013 (through-hole) or the CLC730027 (SOIC) evaluation board as a guide for high-frequency layout and as an aid in device testing and characterization.

This page intentionally left blank.

Customer Design Applications Support

National Semiconductor is committed to design excellence. For sales, literature and technical support, call the National Semiconductor Customer Response Group at **1-800-272-9959** or fax **1-800-737-7018**.

Life Support Policy

National's products are not authorized for use as critical components in life support devices or systems without the express written approval of the president of National Semiconductor Corporation. As used herein:

1. Life support devices or systems are devices or systems which, a) are intended for surgical implant into the body, or b) support or sustain life, and whose failure to perform, when properly used in accordance with instructions for use provided in the labeling, can be reasonably expected to result in a significant injury to the user.
2. A critical component is any component of a life support device or system whose failure to perform can be reasonably expected to cause the failure of the life support device or system, or to affect its safety or effectiveness.



National Semiconductor Corporation

1111 West Bardin Road
Arlington, TX 76017
Tel: 1(800) 272-9959
Fax: 1(800) 737-7018

National Semiconductor Europe

Fax: (+49) 0-180-530 85 86
E-mail: europe.support.nsc.com
Deutsch Tel: (+49) 0-180-530 85 85
English Tel: (+49) 0-180-532 78 32
Francais Tel: (+49) 0-180-532 93 58
Italiano Tel: (+49) 0-180-534 16 80

National Semiconductor Hong Kong Ltd.

2501 Miramar Tower
1-23 Kimberley Road
Tsimshatsui, Kowloon
Hong Kong
Tel: (852) 2737-1600
Fax: (852) 2736-9960

National Semiconductor Japan Ltd.

Tel: 81-043-299-2309
Fax: 81-043-299-2408

National does not assume any responsibility for use of any circuitry described, no circuit patent licenses are implied and National reserves the right at any time without notice to change said circuitry and specifications.