

THOMSON-EFCIS

Integrated Circuits

TEA2015 A

VERTICAL SWEEP FOR BLACK AND WHITE AND 90° COLOR T.V SETS

The TEA2015 A is a complete vertical sweep system designed for TV sets. It includes a fly-back generator, a triggerable ramp generator, a power amplifier, a blanking-pulse generator and safety systems.

Its large output transistors and special "single in-line" case make it able to work without any external power stage and give it a good reliability, it is protected against thermal over load and short-circuit.

MAIN FEATURES

- V_{CC} max. 30 V
60 V (Flyback)
- $I_{OUT} = \pm 1$ A
- No frequency adjustment
- Linearity adjustment possible to suppress
- Frequency and linearity adjustments may be suppressed for standard operation.

VERTICAL SWEEP FOR BLACK AND WHITE AND 90° COLOR TV SETS

CASE CB-230

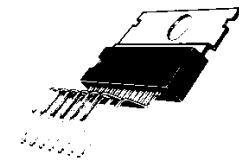

SP SUFFIX
PLASTIC PACKAGE

BLOCK DIAGRAM

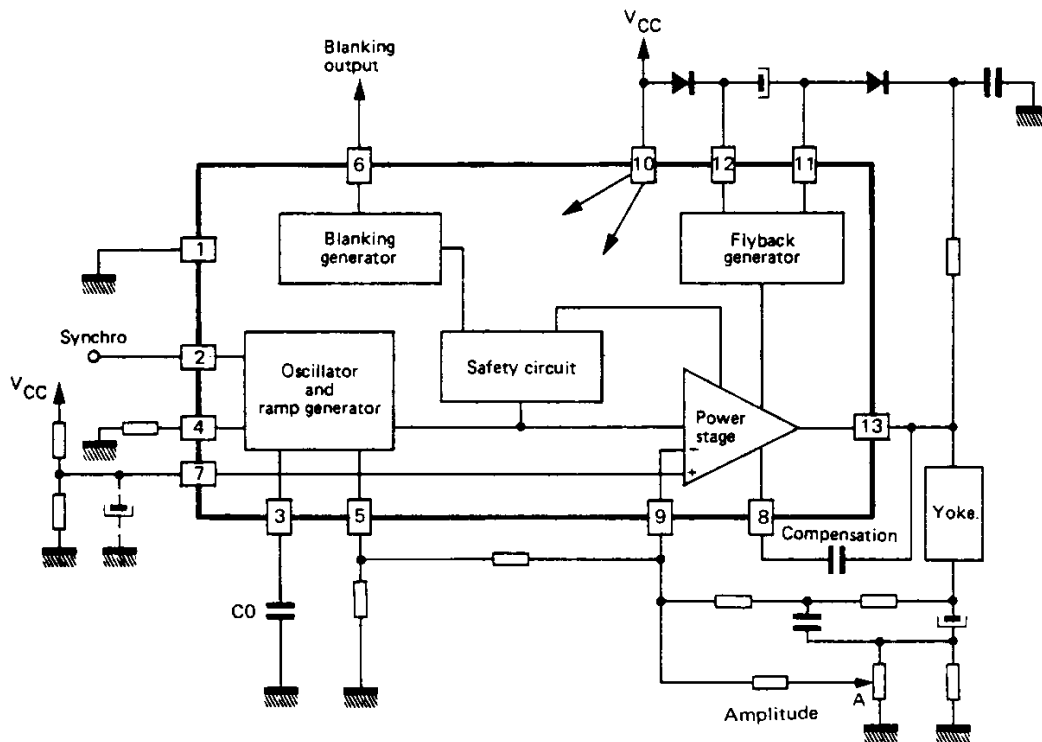

NT4118-A 1/16

THOMSON-EFCIS

Sales headquarters
45, av. de l'Europe - 78140 VELIZY - FRANCE
Tel. : (3) 946 97 19 / Telex : 204780 F

 **THOMSON-CSF**
COMPONENTS

FUNCTIONAL DESCRIPTION

This integrated circuit, specially intended for 90° color TV sets, includes the following built in units :

Oscillator

It provides a linear positive going ramp voltage. The amplitude keeps proportional to V_{CC} . The free running frequency is fixed by external components : one capacitor and one resistor. The frequency drift versus V_{CC} or temperature is very low.

Synchronization

The synchro stage is gated in order to allow input pulse action only during the last fourth of free running period.

Blanking

During normal operation the circuit provides a positive blanking pulse of 12.6 Volts amplitude. The duration is slightly adjustable around 1.3 ms, depending on the value of an external resistor (pin 4).

Power amplifier

The output stage is a complete power amplifier with high current capability, allowing direct driving of deflection coils. It includes thermal and short circuit protection.

Fly-back generator

During the retrace time the output voltage is permitted to reach $2 \times V_{CC}$, due to a built in system (fly-back generator) and few external components.

But, the circuit can be used without fly-back generator.

ABSOLUTE MAXIMUM RATINGS

| | | | |
|----------------------------------|-----------------|------------|----|
| Direct supply voltage | V_{CC} | 35 | V |
| Flyback peak voltage | V_{FB} | 65 | V |
| Output current (repetitive) | I_O | ± 2 | A |
| Output current (non repetitive) | I_O | $\pm 2,5$ | A |
| Storage and junction temperature | $T_j - T_{stg}$ | -40 - +150 | °C |
| Current at pin 13 | | | |
| non repetitive | I_{FB} | $\pm 2,5$ | A |
| repetitive * | I_{FB} | ± 2 | A |

* $t \leq 1$ ms for $t_O = 20$ ms

PIN CONFIGURATION

CASE CB-230



| | | | |
|---|-------------------------------------|----|-----------------------------|
| 1 | Substrate | 7 | Power amplifier + input |
| 2 | Synchronization | 8 | Compensation |
| 3 | Oscillator capacitor | 9 | Power amplifier - input |
| 4 | Reference current | 10 | +V _{CC} |
| 5 | Oscillator output and F. adjustment | 11 | Flyback generator |
| 6 | Blanking output | 12 | V _{CC} power stage |
| | | 13 | Output |

THERMAL CHARACTERISTICS

| | | | |
|-------------------------------------|---------------|----|------|
| Junction-ambient thermal resistance | $R_{th(j-a)}$ | 50 | °C/W |
| Junction-case thermal resistance | $R_{th(j-c)}$ | 7 | °C/W |

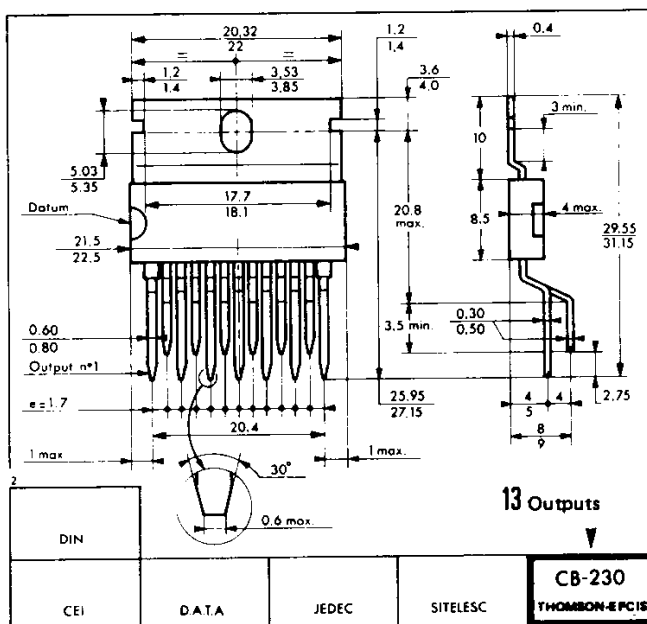

CASE CB-230

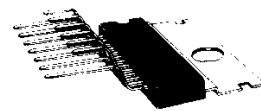
SP SUFFIX
PLASTIC PACKAGE

SCHEMATIC DIAGRAM

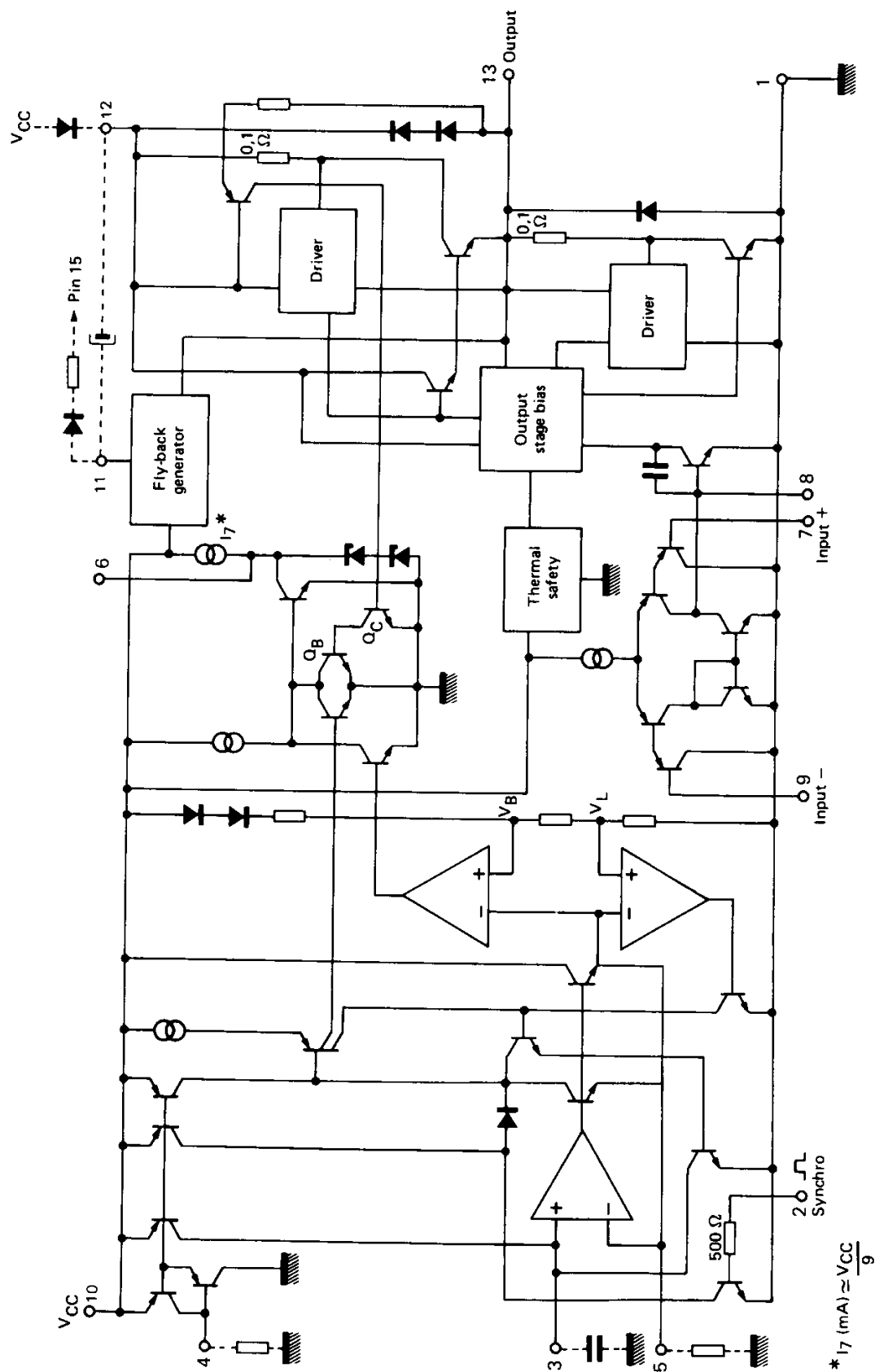

GENERAL ELECTRICAL CHARACTERISTICS (refer to the test circuit) $V_{CC} = 23 \text{ V}$, $T_{amb} = 25^\circ\text{C}$

| PARAMETERS | TEST CONDITIONS | MIN. | TYP. | MAX. | UNITS |
|--|---|------|-----------------|------|--|
| Supply current without load (P10 and P12) | $I(10) + I(12)$ | | 25 | 50 | mA |
| Triggering time (pull-in-range) | $t_o = 23.5 \text{ ms}$ | | 5.8 | | ms |
| Free period time | $C_o = 0.1 \mu\text{F}$ $R4 = 63,4 \text{ k}\Omega$ $R5 = 7,87 \text{ k}\Omega$ | 21,6 | 23.5 | 25,4 | ms |
| Pin 5 peak to peak oscillator saw-tooth voltage | $C_o = 0.1 \mu\text{F}$ $R4 = 63,4 \text{ k}\Omega$ $V_{CC} = 22 \text{ V}$ | | $V_{CC}/3$ | | V |
| Blanking pulse time | $C_o = 0.1 \mu\text{F}$ $R4 = 63,4 \text{ k}\Omega$ | 1,15 | 1.3 | 1,45 | ms |
| Pin 6 blanking pulse amplitude | | | 12.6 | | V |
| Blanking available pin 6* current | | | 150 | | μA |
| Blanking time drift versus temperature $\frac{dt}{dT_j}$ | | | 1 | | $\mu\text{s}/^\circ\text{C}$ |
| Amplifier input bias current | $I(9) - I(7)$ | | 100 | | nA |
| Synchronisation Pin 2 input current Input impedance Maximum voltage | | | 1 0.5 1.5 | | μA $\text{k}\Omega$ V |
| Oscillator frequency drift versus supply voltage $\frac{dF}{dV_{CC}}$ | $V_{CC} = 15 \rightarrow 25 \text{ V}$ | | 0.1 | | Hz/V |
| Oscillator frequency drift versus temperature $\frac{dF}{dT_{case}}$ | | | 0.003 | | Hz/ $^\circ\text{C}$ |
| Thermal protection | | | 140 | | $^\circ\text{C}$ |

* To get an upper blanking current, put an external resistor from 6 to V_{CC}
The pin 6 capability to switching an external current to ground is 4 mA

DYNAMIC TEST CIRCUIT

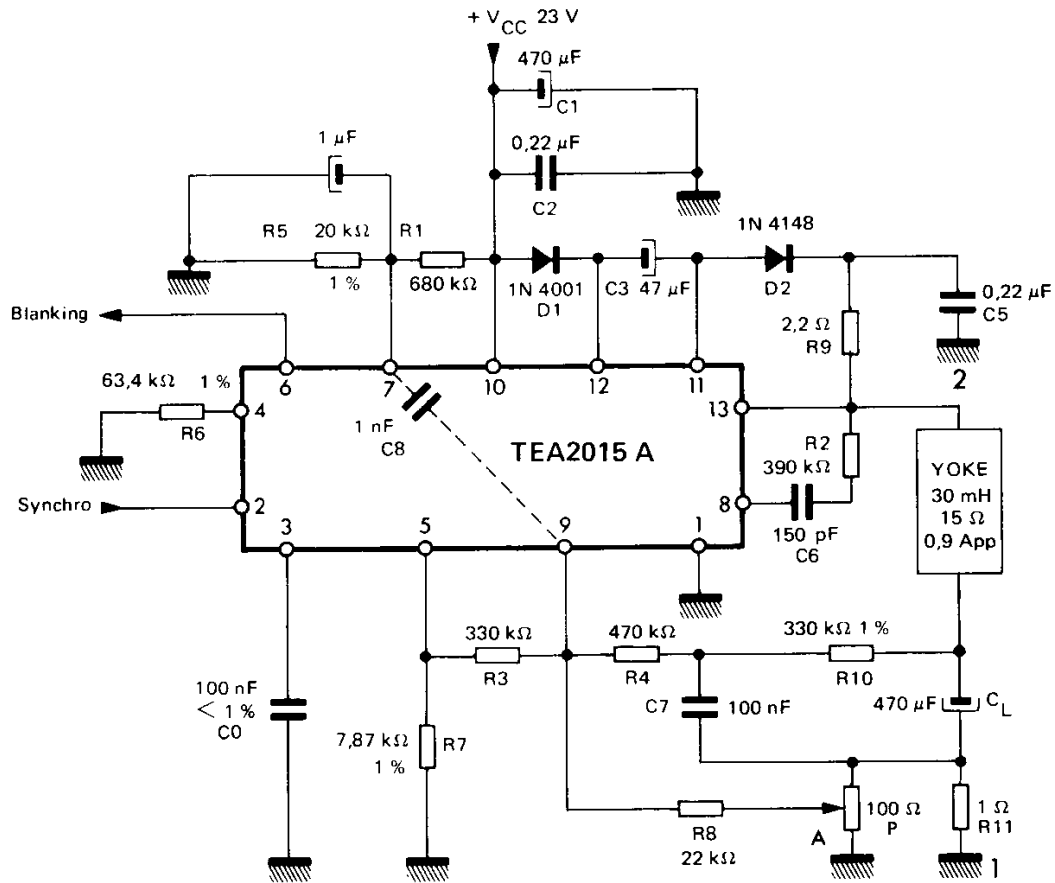

If necessary connect a capacitor 1 nF between pins 9 and 7 to reject line influence.

FREQUENCY VARIATION OF UNSYNCHRONIZED OSCILLATOR VERSUS SUPPLY VOLTAGE

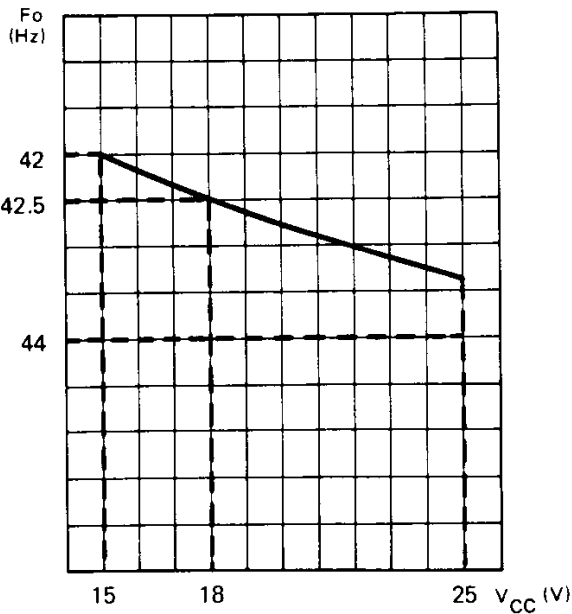

FREQUENCY VARIATION OF UNSYNCHRONIZED OSCILLATOR VERSUS TEMPERATURE

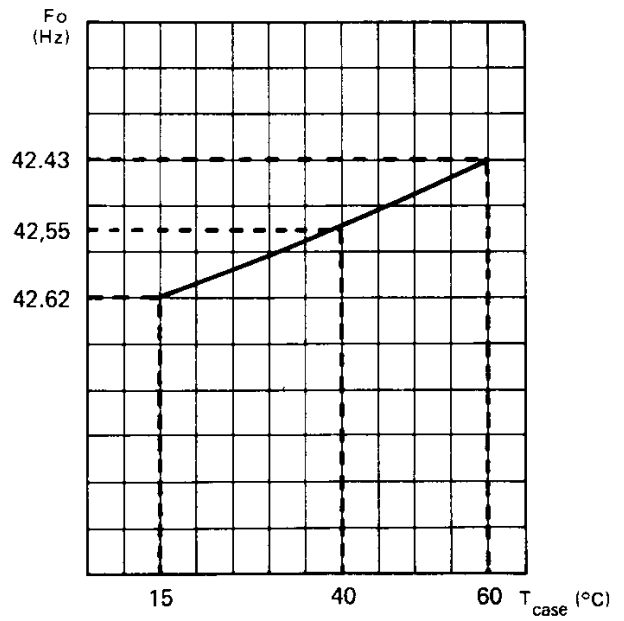

ELECTRICAL CHARACTERISTICS FOR DEFLECTION CIRCUIT WITH VIDEOCOLOR PIL A 421 X SERIES COILS

| PARAMETERS | SYMBOLS | TEST CONDITIONS | MIN. | TYP. | MAX. | UNITS |
|---|----------|--|------|------------|------|------------------|
| YOKE FEATURES PIL S4 | | | | | | |
| Resistance | R_d | | | 15 | | Ω |
| Inductance | L_d | | | 30 | | mH |
| Peak to peak yoke current | I_{CC} | | | 0,9 | | A |
| Supply voltage | V_{CC} | | 20 | 22 | | V |
| Supply current | | $V_{CC} = 22\text{ V}$ | | 155 | | mA |
| Fly-back time | | $V_{CC} = 22\text{ V}$ | | 1 | | ms |
| IC power dissipation | P_D | $V_{CC} = 22\text{ V}$ | | 2,3 | | W |
| Pin 12 operating peak current in fly-back generator | I_{FB} | | | $\pm 0,45$ | | A |
| Non repetitive (accidental) maximum peak current in fly-back | | $t = 1\text{ ms}$ $t_o = 20\text{ ms}$ | | ± 2 | | A |
| Pin 13 non repetitive (accidental) maximum peak output current | | | | $\pm 2,5$ | | A |
| Fly-back voltage | | | | 44 | | V |
| Pin 5 oscillator saw-tooth amplitude | | $C_3 = 100\text{ nF}$ $V_{CC} = 22\text{ V}$ $R_4 = 63,4\text{ k}\Omega$ | | 9 | | V |
| Pin 6 blanking time | | $C_3 = 100\text{ nF}$ $V_{CC} = 22\text{ V}$ $R_4 = 63,4\text{ k}\Omega$ | | 1,3 | | ms |
| Junction temperature with heatsink of $R_{th} = 10^\circ\text{C/W}$ | T_j | $V_{CC} = 22\text{ V}$ $T_{amb} = 30^\circ\text{C}$ | | 70 | | $^\circ\text{C}$ |

ELECTRICAL CHARACTERISTICS FOR SMALL SCREEN/W DEFLECTION CIRCUIT WITH SERIES COILS

| PARAMETERS | SYMBOLS | TEST CONDITIONS | MIN. | TYP. | MAX. | UNITS |
|--|-----------------|--|------|-------|------|-------|
| YOKE FEATURES SERIES COILS | | | | | | |
| Resistance | R _d | | | 14 | | Ω |
| Inductance | L _d | | | 28 | | mH |
| Peak to peak yoke current | I _{CC} | | | 0,6 | | A |
| Supply voltage | V _{CC} | | | 12 | | V |
| Fly-back time | | V _{CC} = 12 V | | 1,2 | | ms |
| Power dissipation in the IC | P _D | V _{CC} = 12 V | | 0,9 | | W |
| Pin 11 operating peak current in fly-back generator | | | | ± 0,3 | | A |
| Non repetitive (accidental) maximum peak current in fly-back | | t _r = 1 ms t _o = 20 ms | | ± 2 | | A |
| Pin 13 non repetitive (accidental) maximum peak output current | | | | ±2,5 | | A |
| Fly-back voltage | | | | 24 | | V |
| Pin 5 oscillator saw-tooth amplitude | | V _{CC} = 12 V | | 4,7 | | V |
| Pin 6 blanking time | | V _{CC} = 12 V | | 1,3 | | ms |
| Junction temperature without heatsink | T _j | V _{CC} = 12 V T _{amb} = 30 °C | | 75 | | °C |

ELECTRICAL CHARACTERISTICS FOR SMALL SCREEN B/W DEFLECTION CIRCUIT WITH PARALLEL COILS

| PARAMETERS | SYMBOLS | TEST CONDITIONS | MIN. | TYP. | MAX. | UNITS |
|--|-----------------|---|------|-------|------|-------|
| YOKE FEATURES PARALLEL COILS | | | | | | |
| Resistance | R _d | | | 3,5 | | Ω |
| Inductance | L _d | | | 7 | | mH |
| Peak to peak yoke current | I _{CC} | | | 1,2 | | A |
| Supply voltage | V _{CC} | | 8,8 | 10,8 | | V |
| Fly-back time | | V _{CC} = 10,8 V | | 0,8 | | ms |
| Power dissipation in the IC | P _D | V _{CC} = 10,8 V | | 1,5 | | W |
| Pin 11 operating peak current in fly-back generator | | | | ± 0,6 | | A |
| Non repetitive (accidental) maximum peak current in fly-back | | t _r = 1 ms t _o = 20 ms | | ± 2 | | A |
| Pin 13 non repetitive (accidental) maximum peak output current | | | | ± 2,5 | | A |
| Fly-back voltage | | | | 21 | | V |
| Pin 5 oscillator saw-tooth amplitude | | V _{CC} = 10,8 V | | 4 | | V |
| Pin 6 blanking time | | V _{CC} = 10,8 V | | 1,3 | | ms |
| Junction temperature with heatsink of R _{th} = 30°C/W | T _j | V _{CC} = 10,8 V T _{amb} = 30°C | | 85 | | °C |

TYPICAL APPLICATION CIRCUIT FOR SMALL SCREEN B/W SET PARALLEL COILS

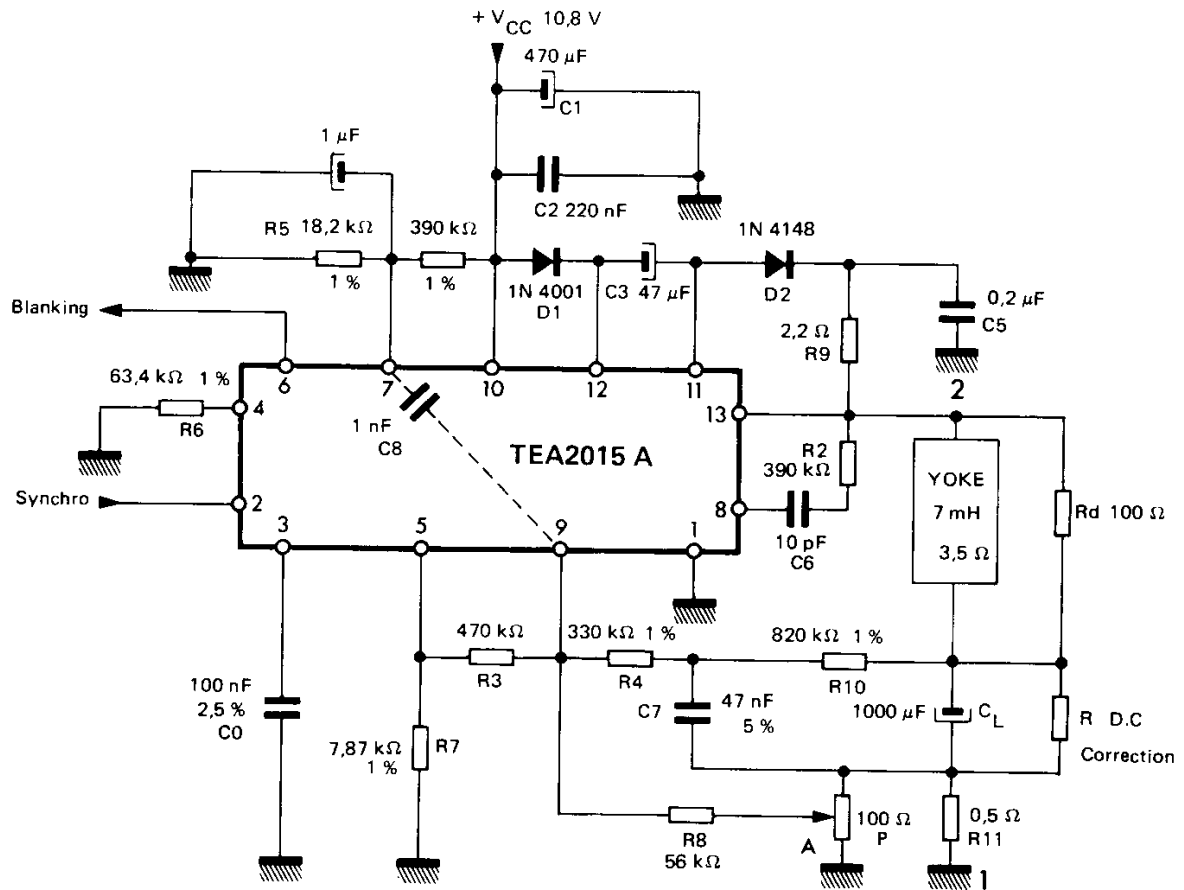

If necessary connect a capacitor 1 nF between pins 9 and 7 to reject line influence.

APPLICATION INFORMATION

Blanking time

Can be adjusted by the value of R4

$$R4 = 63,4 \text{ k}\Omega \quad C_o = 0,1 \text{ }\mu\text{F} \quad t_{\text{blank}} = 1,3 \text{ ms}$$

Automatic format correction

The saw-tooth amplitude is proportional to V_{CC} so that the format is made automatically when the supply voltage is given by the horizontal transformer. In an other case two other possibilities.

a – When the voltage correction coming from the beam current increase and the amplitude must decrease.

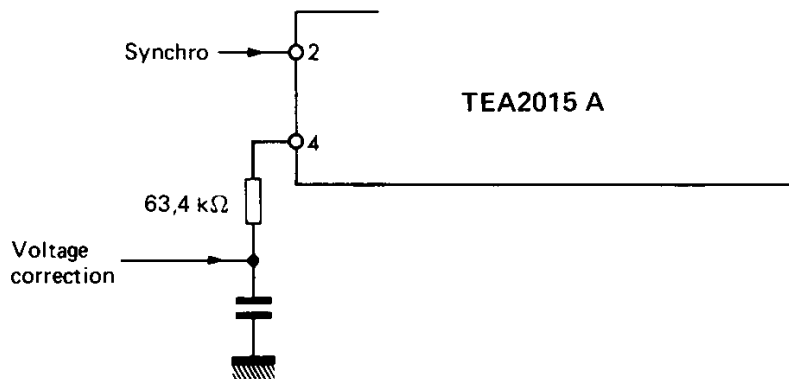

Format correction 5 %
 V_{CC} 20 V
 Voltage correction 0 - 1 V
 No effect on the free frequency

In this case if the amplitude decreases of 5%
 the blanking time increases of 5%.

b – When the voltage correction decreases and the amplitude must decrease

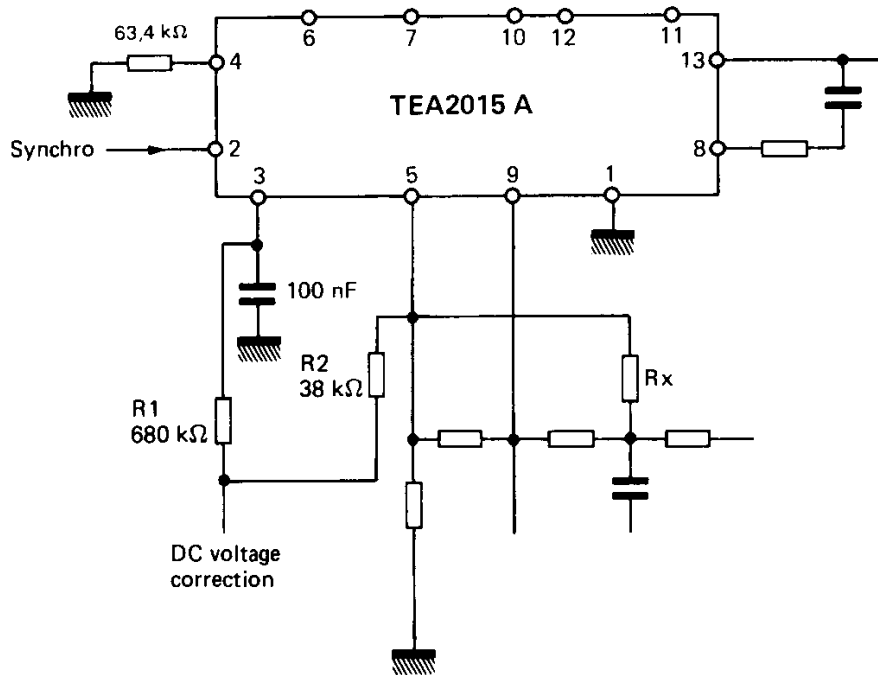

Rx must be adjusted to compensate the parabolic effect of R1 if there is no linearity adjustment.

Format correction 5 %
 DC voltage correction 2 V – 0
 V_{CC} 20 V

- no effect on free frequency
- Blanking time variation $\leq 3 \%$

Synchronization network for synchro coming from TBA 920 Pin 7

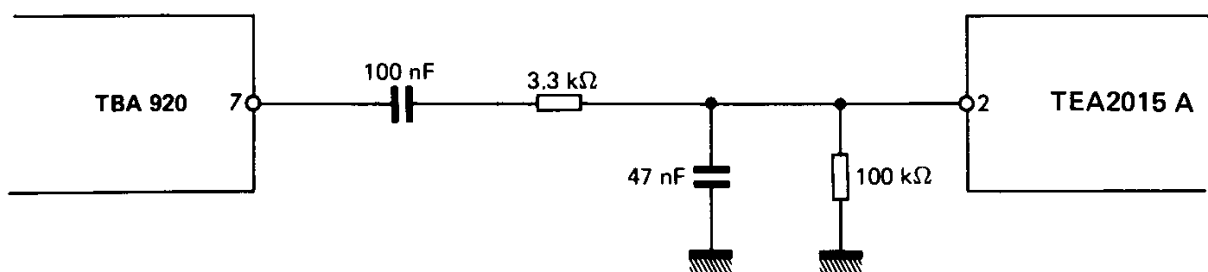

Automatic standard switching with constant amplitude (50 Hz - 60 Hz)

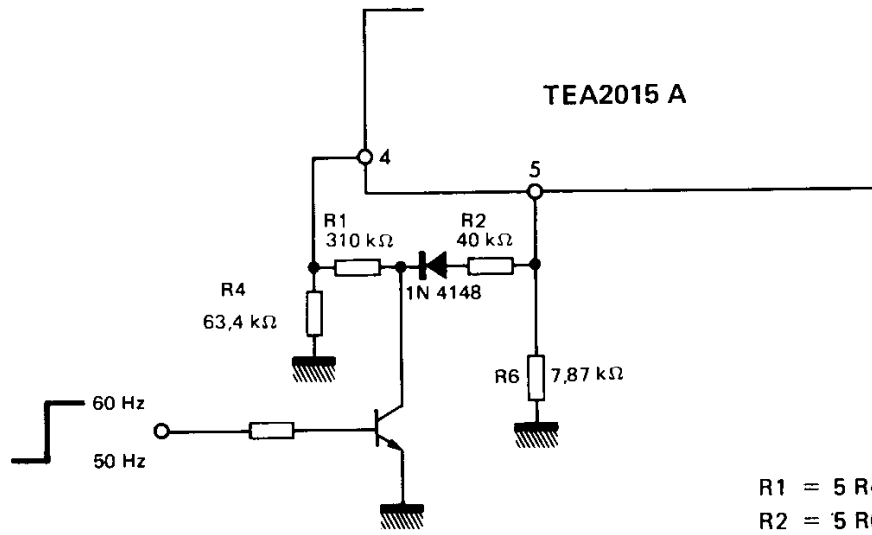

Printed circuit board layout information referred to the application diagram 90° COLOR TV SET

COMPONENT SIDE

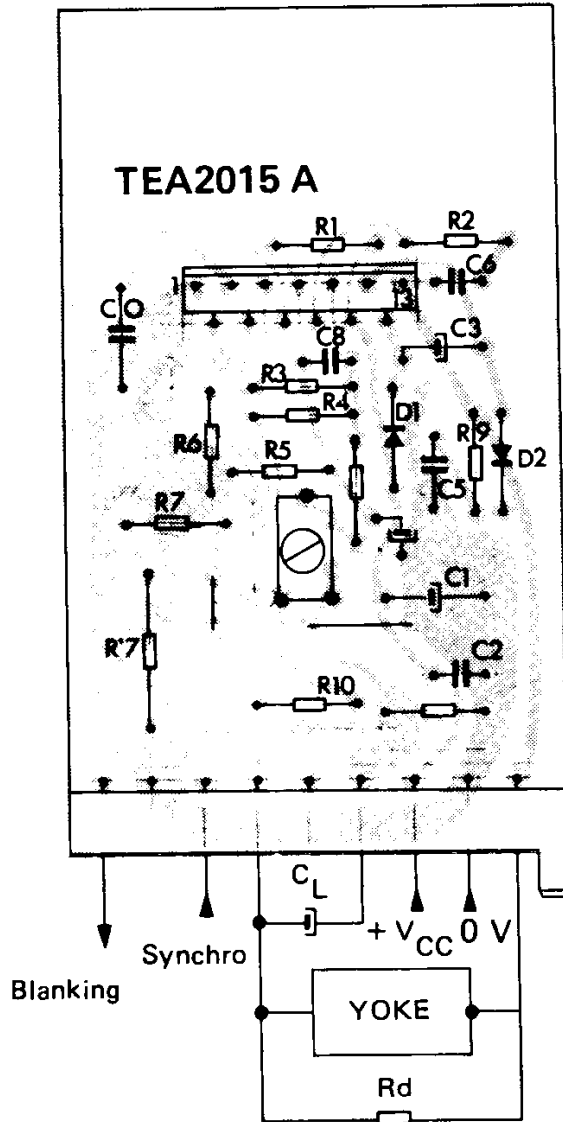

COPPER SIDE

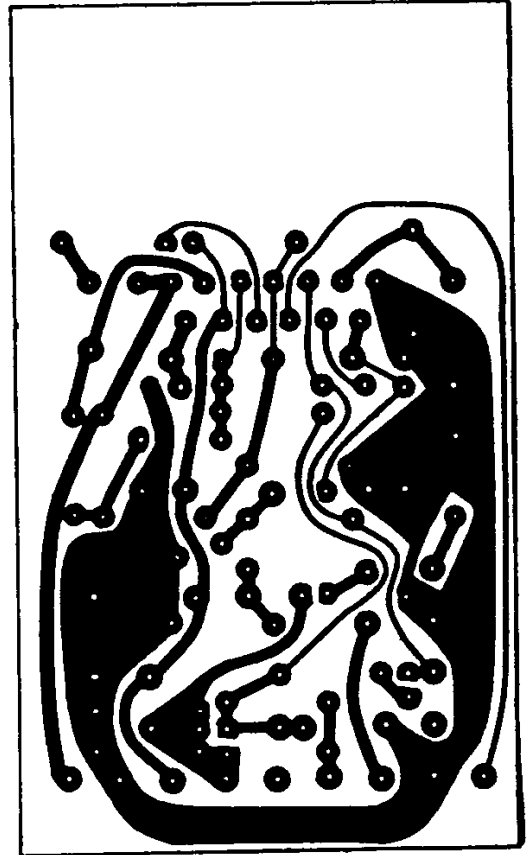

Each power ground 1, 2, 3 (refer to the application diagram 90° COLOR TV SET) must be connected to the -supply (pin 1) with a minimum copper resistance.
 Other grounds (oscillator and outputs) must be well decoupled from the power ground and connected to the -supply.
 Copper connections to pins 7 and 9 as short as possible to reject the line influence.

These specifications are subject to change without notice.
 Please inquire with our sales offices about the availability of the different packages.