



TDA2005

LINEAR INTEGRATED CIRCUIT

20W BRIDGE AMPLIFIER FOR CAR RADIO

DESCRIPTION

The UTC TDA2005 is class B dual audio power amplifier, have designed for car radio application.

FEATURES

* High output power:

$$P_{OUT}=10+10W@R_L=2\ \Omega, THD=10\%$$

$$P_{OUT}=20W@R_L=4\ \Omega, THD=1\%$$

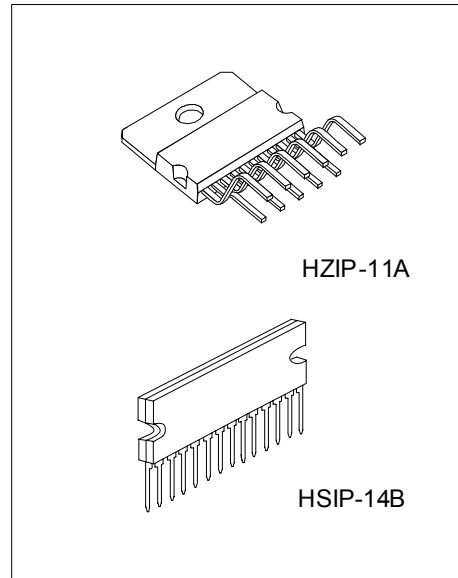

*Pb-free plating product number: TDA2005L

ORDERING INFORMATION

| Ordering Number | | Package | Packing |
|-----------------|-------------------|----------|---------|
| Normal | Lead Free Plating | | |
| TDA2005-J11-A-T | TDA2005L-J11-A-T | HZIP-11A | Tube |
| TDA2005-H14-B-T | TDA2005L-H14-B-T | HSIP-14B | Tube |

| | |
|--|--|
| <p>TDA2005L-J11-A-T</p> <p>(1)Packing Type (2)Package Type (3)Lead Plating</p> | <p>(1) T: Tube (2) J11-A:HZIP-11A, H14-B:HSIP-14B (3) Lead Free Plating, Blank Pb/Sn</p> |
|--|--|

PIN DESCRIPTION

| PIN NO. | | PIN NAME |
|---------|----------|-----------------|
| HZIP-11 | HSIP-14* | |
| 1 | 1 | INPUT+ (1) |
| 2 | 2 | INPUT- (1) |
| 3 | 3 | SVRR |
| 4 | 4 | INPUT- (2) |
| 5 | 5 | INPUT+ (2) |
| 6 | 6 | GND |
| 7 | 10 | BOOTSTRAP 2 |
| 8 | 11 | OUTPUT 2 |
| 9 | 12 | +V _s |
| 10 | 13 | OUTPUT 1 |
| 11 | 14 | BOOTSTRAP 1 |

* PIN 7, 8, 9 no connection.

■ PIN CONFIGURATION

HZIP-11A

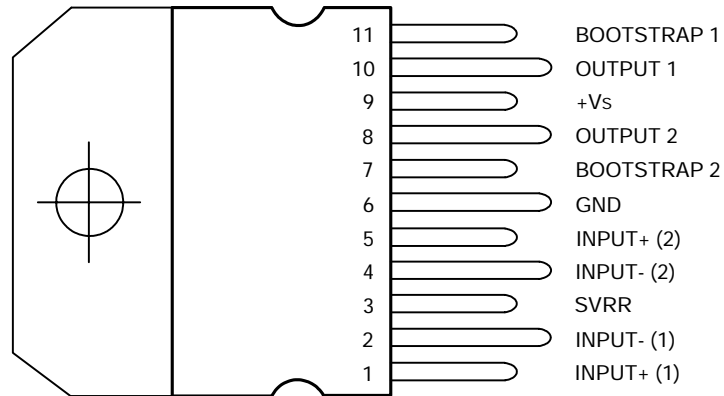

*TAB CONNECTED TO PIN 6

HSIP-14B

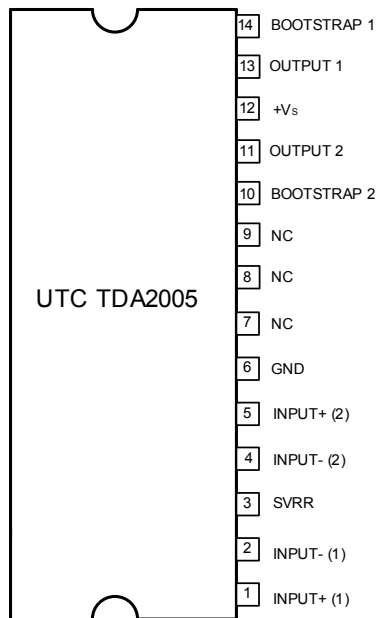

■ BLOCK DIAGRAM

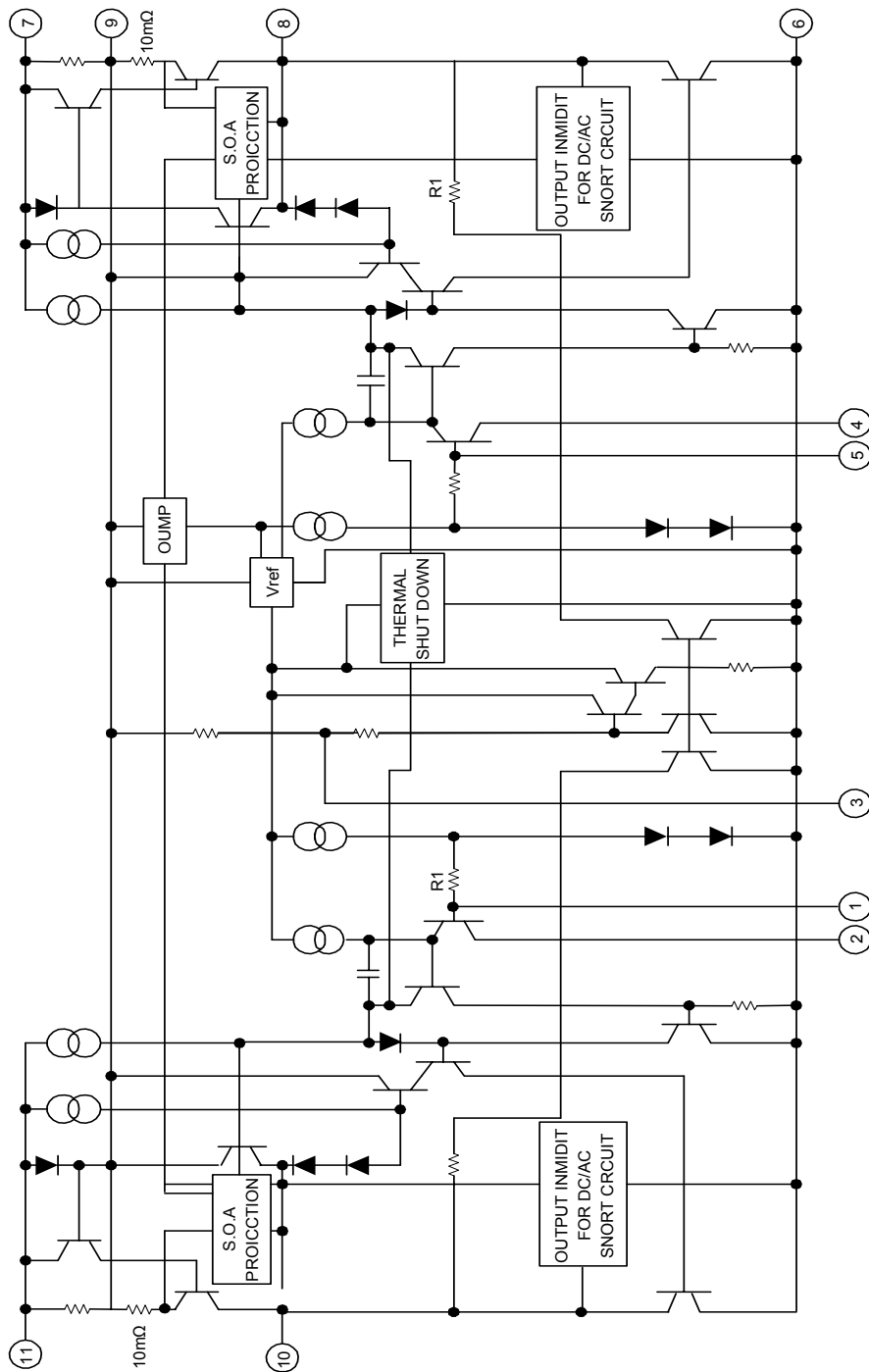

■ ABSOLUTE MAXIMUM RATINGS

| PARAMETER | SYMBOL | RATINGS | UNIT | |
|---|------------------------|----------------|------|---|
| Operating Supply Voltage | V _{SS} | 18 | V | |
| DC Supply Voltage | V _{SS} | 28 | V | |
| Peak Supply Voltage (for 50ms) | V _{SS} | 40 | V | |
| Output Peak Current (Note) | non repetitive t=0.1ms | I _O | 4.5 | A |
| | repetitive f 10Hz | I _O | 3.5 | A |
| Power Dissipation at T _c =60 | P _D | 30 | W | |
| Junction Temperature | T _J | +150 | | |
| Storage Temperature | T _{STG} | -40 ~ 150 | | |

Note: The max. output current is internally limited.

■ THERMAL DATA

| PARAMETER | SYMBOL | RATINGS | UNIT |
|----------------------------------|-----------------|---------|------|
| Thermal Resistance Junction-Case | θ _{JC} | 3.0 | /W |

■ ELECTRICAL CHARACTERISTICS

(Refer to the application circuit, T_a=25 °C, G_v=50dB, R_{th}(heatsink)=4 °C/W, unless otherwise specified.)

| PARAMETER | SYMBOL | TEST CONDITIONS | MIN | TYP | MAX | UNIT |
|--|------------------|--|-----|-----|-----|------|
| BRIDGE | | | | | | |
| Supply Voltage | V _{SS} | | 8 | | 18 | V |
| Output Offset Voltage (between pin 8 and pin 10) | V _{OS} | V _{SS} =14.4V | | | 150 | mV |
| | | V _{SS} =13.2V | | | 150 | mV |
| Total Quiescent Drain Current | I _D | V _{SS} =14.4V, R _L =4 | | 75 | 150 | mA |
| | | V _{SS} =13.2V, R _L =3.2 | | 70 | 160 | mA |
| Output Power | P _{OUT} | THD=10%, f=1kHz V _{SS} =14.4V, R _L =4 R _L =3.2 | 18 | 20 | | W |
| | | V _{SS} =13.2V, R _L =3.2 | 20 | 22 | | |
| | | | 17 | 19 | | |
| Total Harmonic Distortion f=1kHz | THD | V _{SS} =14.4V, R _L =4 P _{OUT} =50mW ~ 15W | | | 1 | % |
| | | V _{SS} =13.2V, R _L =3.2 P _{OUT} =50mW ~ 13W | | | 1 | % |
| Input Sensitivity f=1kHz | V _{IN} | P _{OUT} =2W, R _L =4 | | 9 | | mV |
| | | P _{OUT} =2W, R _L =3.2 | | 8 | | mV |
| Input Resistance | R _{IN} | f=1kHz | 70 | | | k |
| Low Frequency Roll Off (-3dB) | f _L | R _L =3.2 | | | 40 | Hz |
| High Frequency Roll Off (-3dB) | f _H | R _L =3.2 | 20 | | | kHz |
| Closed Loop Voltage Gain | G _V | f=1kHz | | 50 | | dB |
| Total Input Noise Voltage | e _N | R _G =10k (Note 1) | | 3 | 10 | μV |
| Supply Voltage Rejection | SVR | R _G =10k, C ₄ =10 μF F _{RIPPLE} =100Hz, V _{RIPPLE} =0.5V | 45 | 55 | | dB |
| Efficiency | | V _{SS} =14.4V, f=1kHz P _{OUT} =20W, R _L =4 P _{OUT} =22W, R _L =3.2 | | 60 | | % |
| | | V _{SS} =13.2V, f=1kHz P _{OUT} =19W, R _L =3.2 | | 58 | | % |
| Thermal Shut-down Junction Temperature | T _J | V _{SS} =14.4V, R _L =4 f=1kHz, P _D =13W | | 145 | | |
| Output Voltage With One Side of the Speaker Shorted to Ground | V _{OSH} | V _{SS} =14.4V, R _L =4 V _{SS} =13.2V, R _L =3.2 | | | 2 | V |

■ ELECTRICAL CHARACTERISTICS(Cont.)

| PARAMETER | SYMBOL | TEST CONDITIONS | MIN | TYP | MAX | UNIT | |
|--|------------------|--|---|----------|-----|--------|---|
| STEREO | | | | | | | |
| Supply Voltage | V _{SS} | | 8 | | 18 | V | |
| Quiescent Output Voltage | V _{OUT} | V _{SS} =14.4V | 6.6 | 7.2 | 7.8 | V | |
| | | V _{SS} =13.2V | 6 | 6.6 | 7.2 | V | |
| Total Quiescent Drain Current | I _D | V _{SS} =14.4V | | 65 | 120 | mA | |
| | | V _{SS} =13.2V | | 62 | 120 | mA | |
| Output Power (each channel) f=1Hz, THD=10% | P _{OUT} | V _{SS} =14.4V | R _L =4 | 6 | 6.5 | | W |
| | | | R _L =3.2 | 7 | 8 | | |
| | | | R _L =2 | 9 | 10 | | |
| | | V _{SS} =13.2V | R _L =3.2 | 6 | 6.5 | | |
| | | | R _L =1.6 | 9 | 10 | | |
| | | | V _{SS} =16V, R _L =2 | | 12 | | |
| Total Harmonic Distortion (each channel) f=1KHz | THD | V _{SS} =14.4V, R _L =4 P _{OUT} =50mW ~ 4W | | 0.2 | 1 | % | |
| | | V _{SS} =14.4V, R _L =2 P _{OUT} =50mW ~ 6W | | 0.3 | 1 | % | |
| | | V _{SS} =13.2V, R _L =3.2 P _{OUT} =50mW ~ 3W | | 0.2 | 1 | % | |
| | | V _{SS} =13.2V, R _L =1.6 P _{OUT} =40mW ~ 6W | | 0.3 | 1 | % | |
| Cross Talk | C _T | V _{SS} =14.4V, V _{OUT} =4VRMS R _L =4 , R _G =5K | f=1KHz | | 60 | dB | |
| | | | f=10kHz | | 45 | | |
| Input Saturation Voltage | V _{IN} | | 300 | | | mV | |
| Input Sensitivity | V _{IN} | f=1kHz, P _{OUT} =1W R _L =4 R _L =3.2 | | 6 5.5 | | m V | |
| Input Resistance | R _{IN} | f=1kHz | 70 | 200 | | k | |
| Low Frequency Roll Off (-3dB) | f _L | R _L =2 | | | 50 | Hz | |
| High Frequency Roll Off (-3dB) | f _H | R _L =2 | 15 | | | kHz | |
| Voltage Gain (open loop) | G _V | f=1kHz | | 90 | | dB | |
| Voltage Gain (close loop) | G _V | f=1kHz | 48 | 50 | 51 | dB | |
| Closed Loop Gain Matching | G _V | | | 0.5 | | dB | |
| Total Input Noise Voltage | E _n | R _G =10k (Note 1) | | 1.5 | 5 | μV | |
| Supply Voltage Rejection | SVR | R _G =10k , C3=10 μF F _{RIIPPLE} =100Hz, V _{RIIPPLE} =0.5V | 35 | 45 | | dB | |
| Efficiency | | V _{SS} =14.4V, f=1kHz P _{OUT} =6.5W, R _L =4 P _{OUT} =10W, R _L =2 | | 70 60 | | % % | |
| | | V _{SS} =13.2V, f=1kHz P _{OUT} =6.5W, R _L =3.2 P _{OUT} =100W, R _L =1.6 | | 70 60 | | % % | |

Note: 1. Bandwith Filter: 22Hz ~ 22kHz

TEST AND APPLICATION CIRCUIT

Bridge amplifier

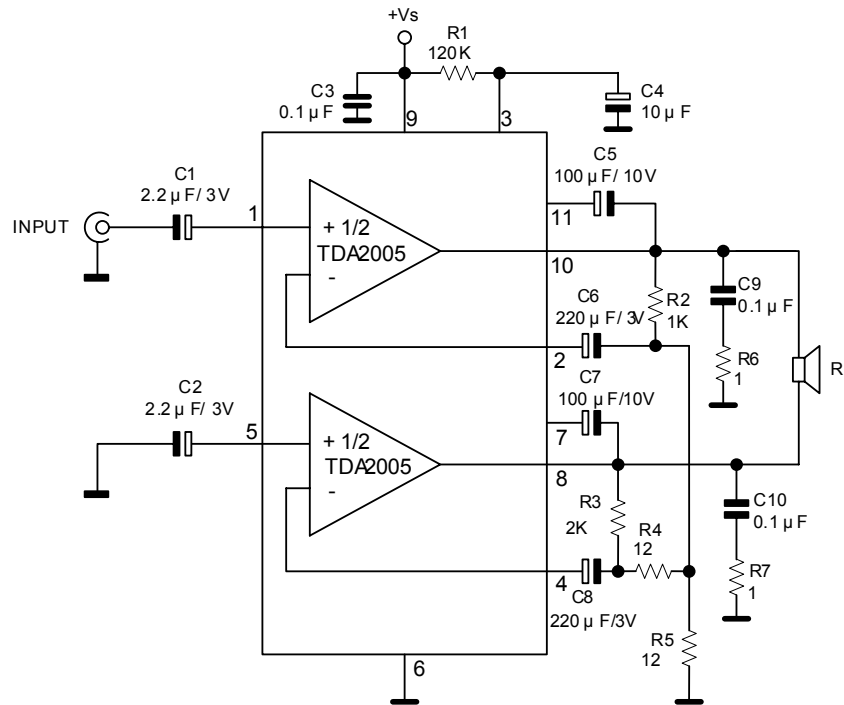

Stereo amplifier

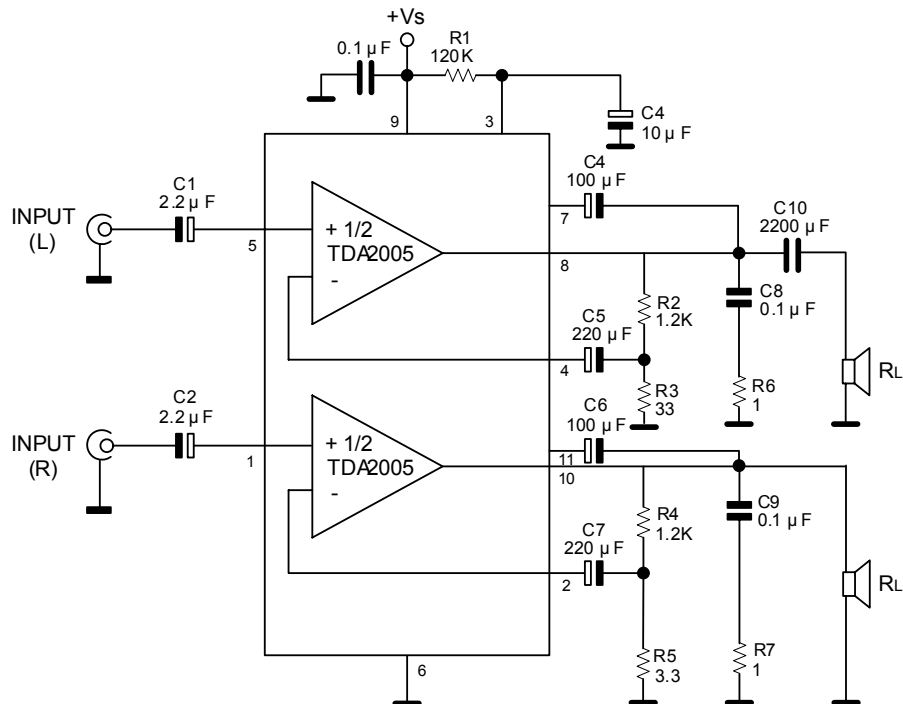

BRIDGE AMPLIFIER DESIGN

The following considerations can be useful when designing a bridge amplifier.

| PARAMETER | | SINGLE ENDED | BRIDGE |
|----------------|---------------------------------------|---|---------------------------------------|
| $V_{OUT\ max}$ | Peak Output Voltage (before clipping) | $\frac{1}{2} (V_s - 2V_{CE\ sat})$ | $V_s - 2V_{CE\ sat}$ |
| $I_{OUT\ max}$ | Peak Output Current (before clipping) | $\frac{1}{2} \frac{V_s - 2V_{CE\ sat}}{R_L}$ | $\frac{V_s - 2V_{CE\ sat}}{R_L}$ |
| $P_{OUT\ max}$ | RMS Output Power (before clipping) | $\frac{1}{4} \frac{(V_s - 2V_{CE\ sat})^2}{2R_L}$ | $\frac{(V_s - 2V_{CE\ sat})^2}{2R_L}$ |

Where: $V_{CE\ sat}$ =output transistors saturation voltage

V_s =allowable supply voltage

R_L =load impedance

Voltage and current swings are twice for a bridge amplifier in comparison with single ended amplifier. In other words, with the same R_L the bridge configuration can deliver an output power that is four times the output power of a single ended amplifier, while, with the same max output current the bridge configuration can deliver an output power that is twice the output power of a single ended amplifier. Care must be taken when selecting V_s and R_L in order to avoid an output peak current above the absolute maximum rating.

From the expression for $I_{o\ max}$, assuming $V_s=14.4V$ and $V_{CE\ sat}=2V$, the minimum load that can be driven by UTC TDA2005 in bridge configuration is:

$$R_L\ min = \frac{V_s - 2V_{CE\ sat}}{I_{OUT\ max}} = \frac{14.4 - 4}{3.5} = 2.97$$

The voltage gain of the bridge configuration is given by (see Figure 3):

$$G_v = \frac{V_0}{V_1} = 1 + \frac{R_1}{\left(\frac{R_2 \cdot R_4}{R_2 + R_4}\right)} + \frac{R_3}{R_4}$$

For sufficiently high gains (40 ~ 50dB) it is possible to put $R_2=R_4$ and $R_3=2R_1$, simplifying the formula in:

$$G_v = 4 \frac{R_1}{R_2}$$

| G_v (dB) | R_1 () | $R_2=R_4$ () | R_3 () |
|------------|-----------|---------------|-----------|
| 40 | 1000 | 39 | 2000 |
| 50 | 1000 | 12 | 2000 |

Bridge Configuration

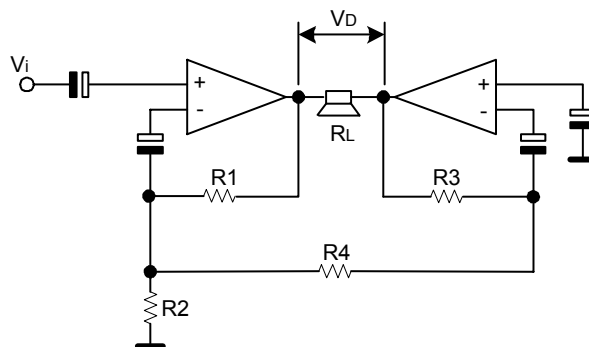

APPLICATION INFORMATION

Bridge Amplifier without Bootstrap

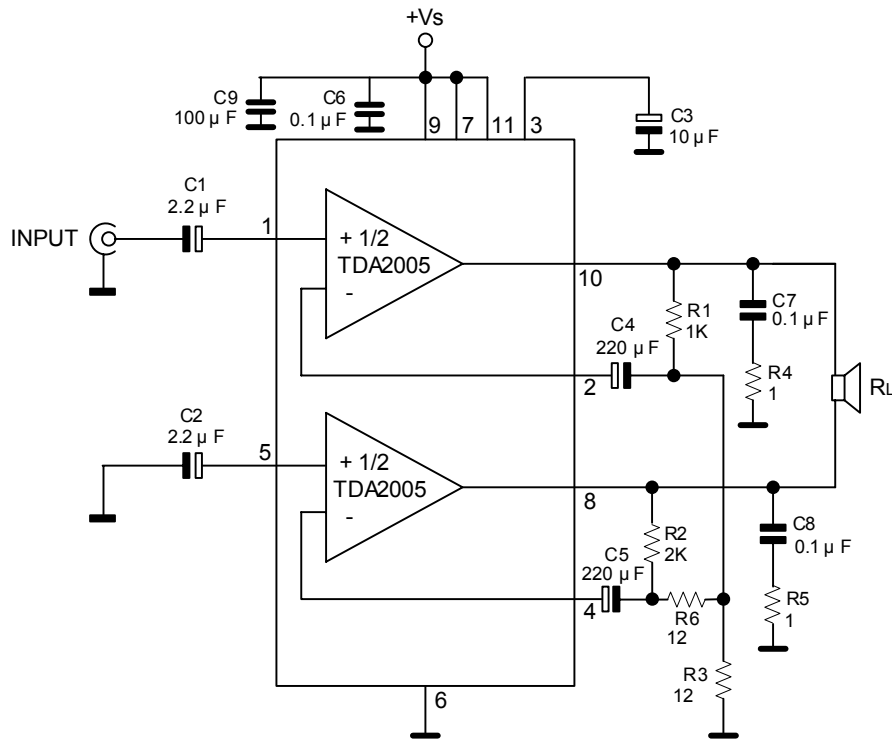

Low Cost Bridge Amplifier (Gv=42dB)

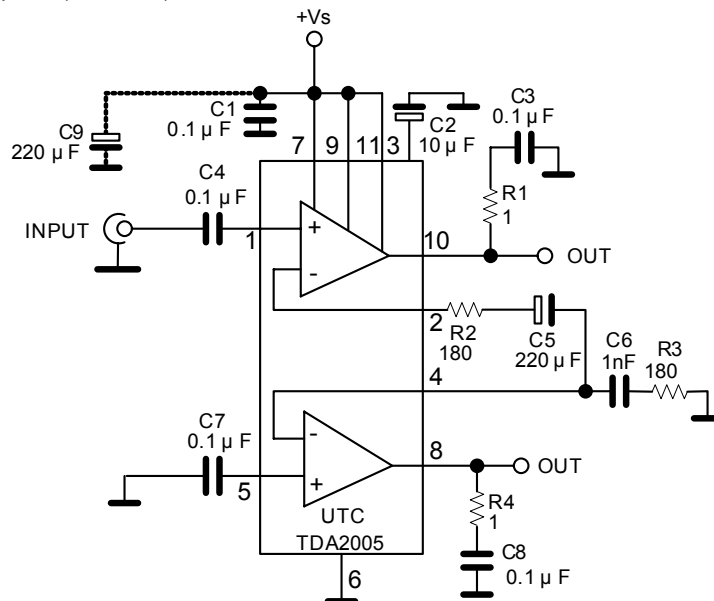

■ APPLICATION INFORMATION(Cont.)

10+10W Stereo Amplifier with Tone Balance and Loudness Control

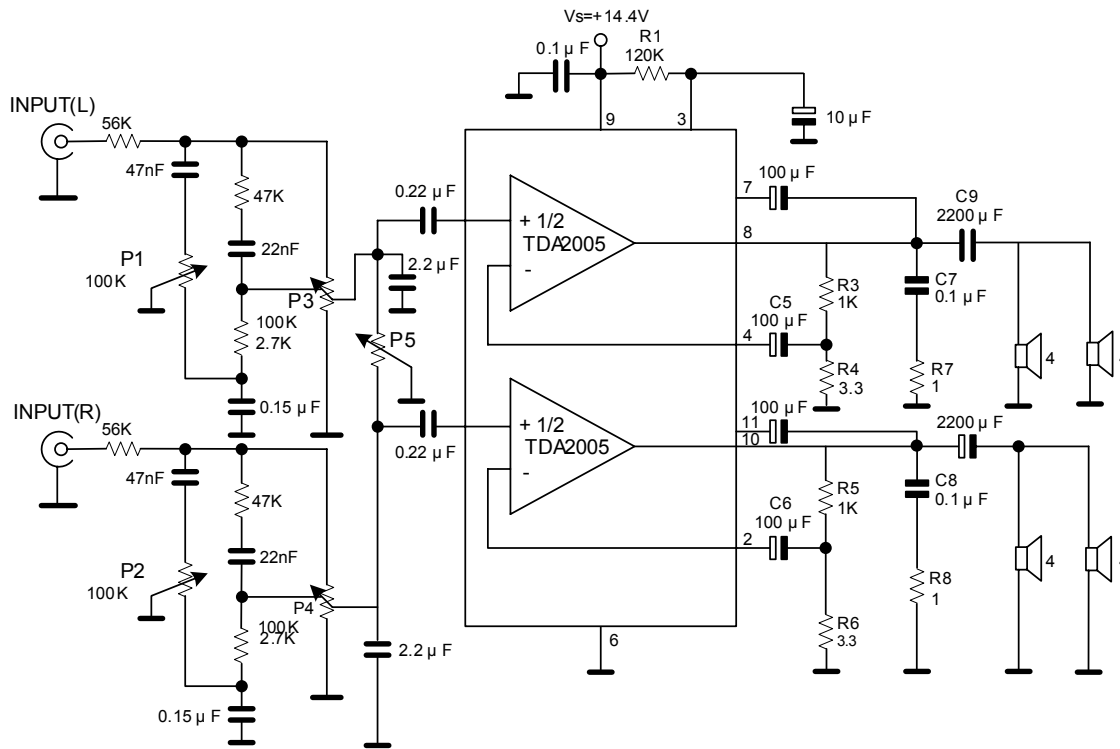

Tone Control Response (circuit of Figure 8)

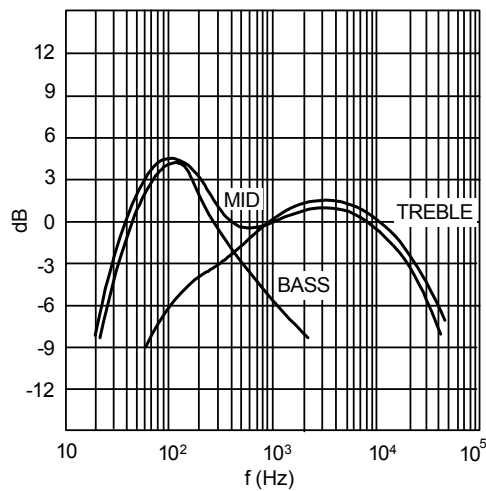

APPLICATION INFORMATION(Cont.)

20W Bus Amplifier

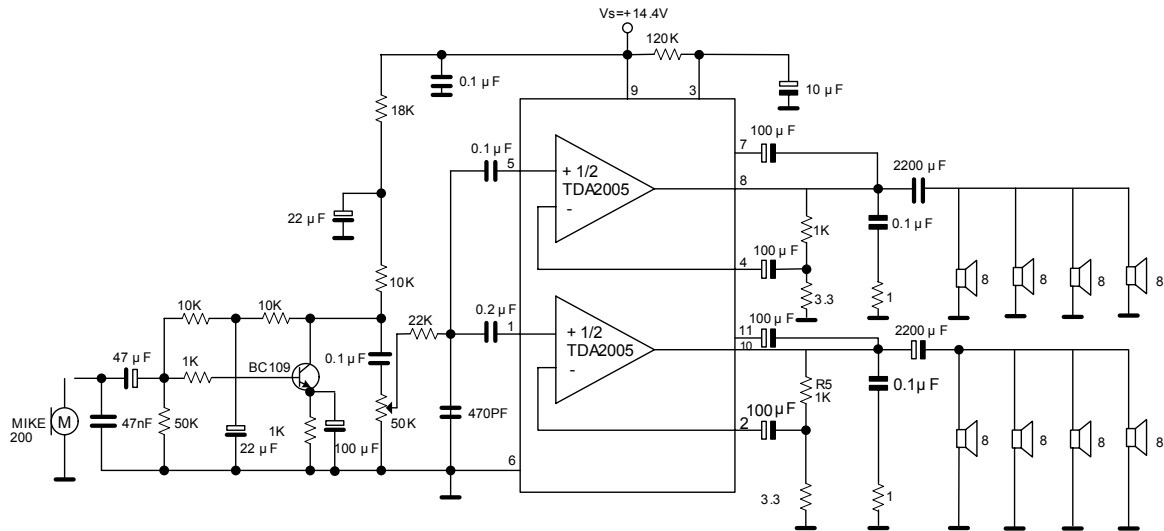

Simple 20W Two Way Amplifier (Fc=2kHz)

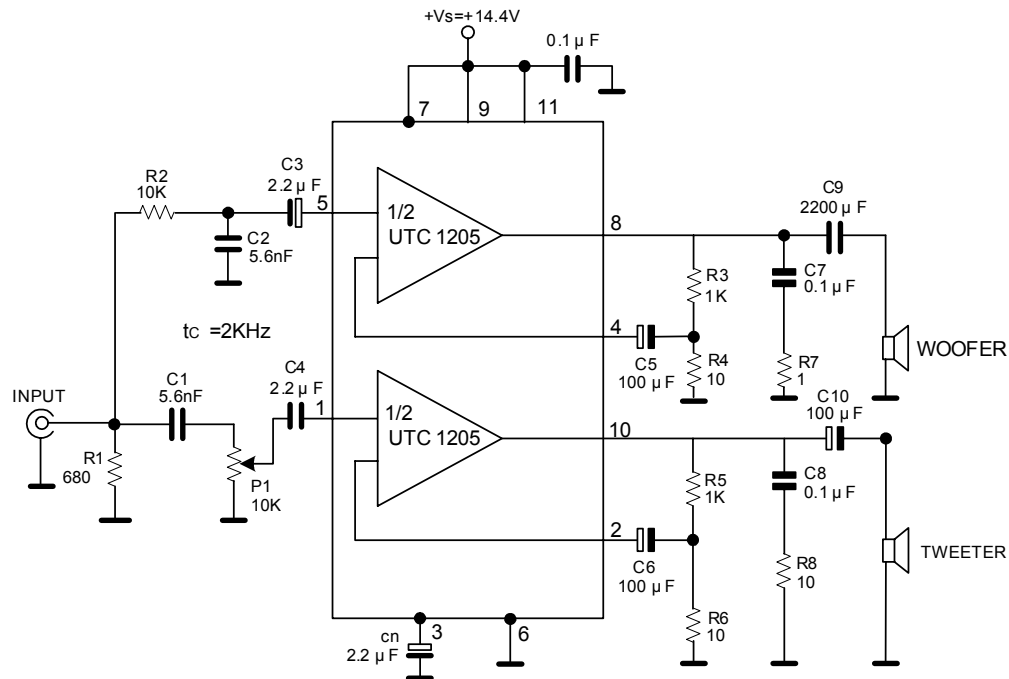

■ APPLICATION INFORMATION(Cont.)

Bridge Amplifier Circuit suited for Low-gain Applications ($G_v=34\text{dB}$)

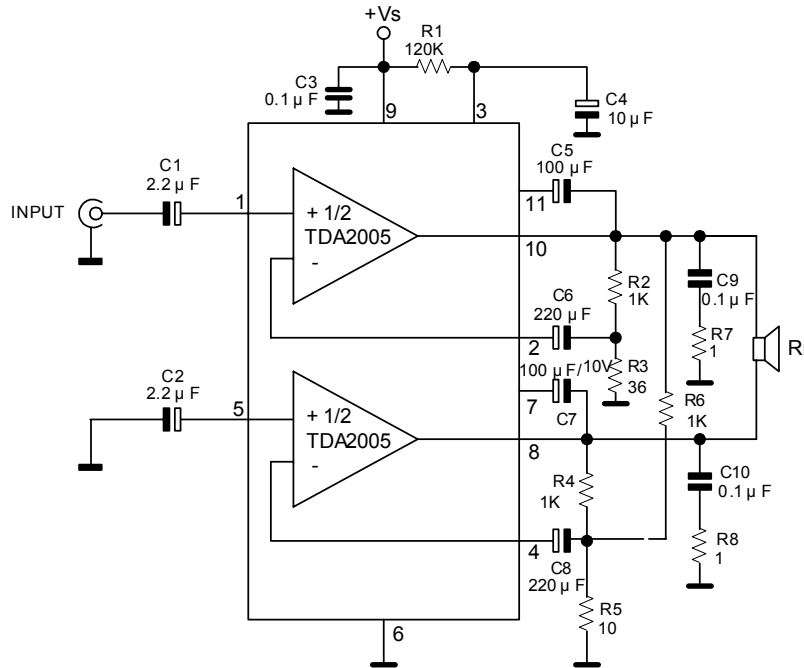
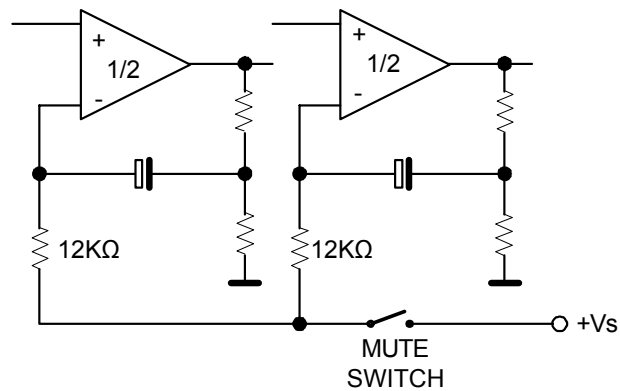

Figure 1. Example of Muting Circuit



■ BUILT-IN PROTECTION SYSTEMS

LOAD DUMP VOLTAGE SURGE

The UTC TDA2005 has a circuit which enables it to withstand a voltage pulse train, on pin9, of the type shown in Figure 3.

If the supply voltage peaks to more than 40V, then an LC filter must be inserted between the supply and pin9, in order to assure that the pulses at pin 9 will be held within the limits shown.

A suggested LC network is shown in Figure 2. With this network, a train of pulses with amplitude up to 120V and width of 2ms can be applied at point A. This type of protection is ON when the supply voltage (pulse or DC) exceeds 18V. For this reason the maximum operating supply voltage is 18V.

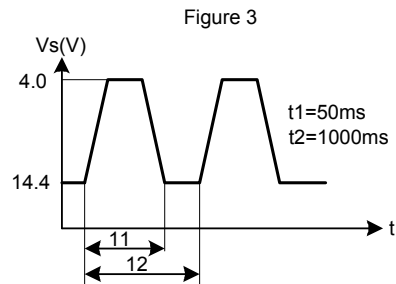
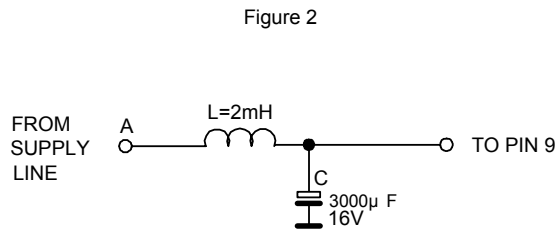

SHORT CIRCUIT (AC AND DC CONDITIONS)

The UTC TDA2005 can withstand a permanent short circuit on the output for a supply voltage up to 16V.

POLARITY INVERSION

High current (up to 10A) can be handled by the device with no damage for a longer period than the blow-out time of a quick 2A fuse (normally connected in series with the supply). This feature is added to avoid destruction, if during fitting to the car, a mistake on the connection of the supply is made.

OPEN GROUND

When the ratio is in the ON condition and the ground is accidentally opened, a standard audio amplifier will be damaged. On the UTC TDA2005 protection diodes are included to avoid any damage.

INDUCTIVE LOAD

A protection diode is provided to allow use of the UTC TDA2005 with inductive loads.

DC VOLTAGE

The maximum operating DC voltage for the UTC TDA2005 is 18V.

However the device can withstand a DC voltage up to 28V with no damage. This could occur during winter if two batteries are series connected to crank the engine.

THERMAL SHUT-DOWN

The presence of a thermal limiting circuit offers the following advantages:

(1). An overload on the output (even if it is permanent), or an excessive ambient temperature can be easily withstood.

(2). The heatsink can have a smaller factor of safety compared with that of a conventional circuit. There is no device damage in the case of excessive junction temperature; all that happens is that P_o (and therefore P_{tot}) and I_d are reduced.

The maximum allowable power dissipation depends upon the size of the external heatsink (i.e. its thermal resistance); Figure 4 shows the dissipation power as a function of ambient temperature for different thermal resistance.

LOUDSPEAKER PROTECTION

The circuit offers loudspeaker protection during short circuit for one wire to ground.

TYPICAL CHARACTERISTICS

Figure 4. Maximum Allowable Power Dissipation versus Ambient Temperature

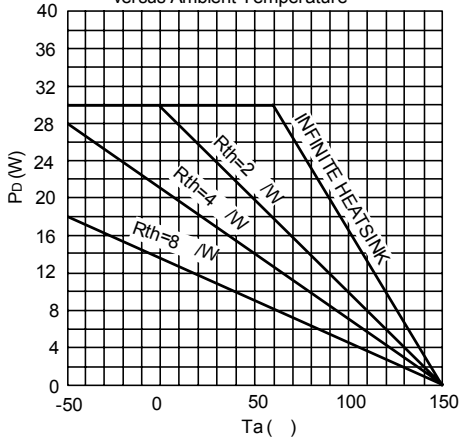

Figure 5. Output Power and Drain Current Versus Case Temperature

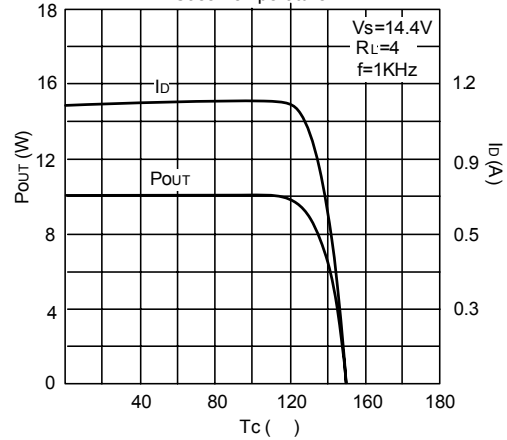

Figure 6. Output Power and Drain Current Versus Case Temperature

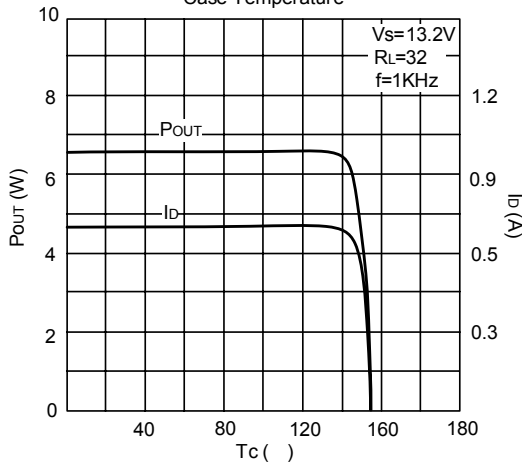

Figure 7. Output Offset Voltage versus Supply Voltage

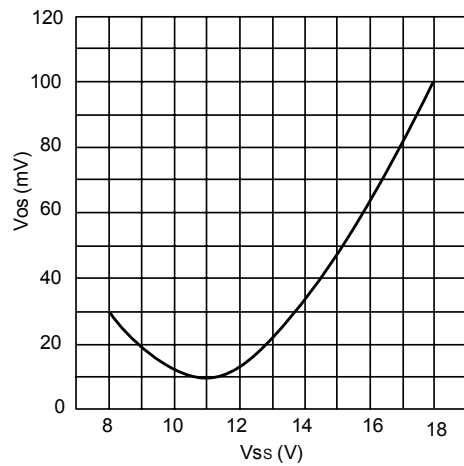

Figure 8. Distortion versus Output Power (bridge amplifier)

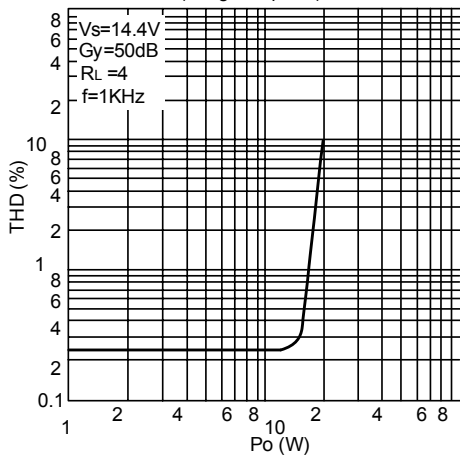
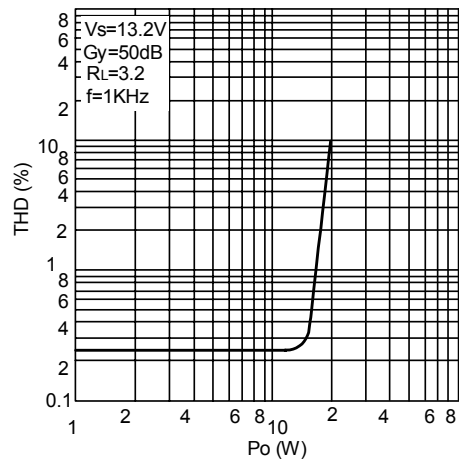

Figure 9. Distortion versus Output Power (bridge amplifier)



TYPICAL CHARACTERISTICS (cont.)

Figure 10. Quiescent Output Voltage versus Supply Voltage (Stereo amplifier)

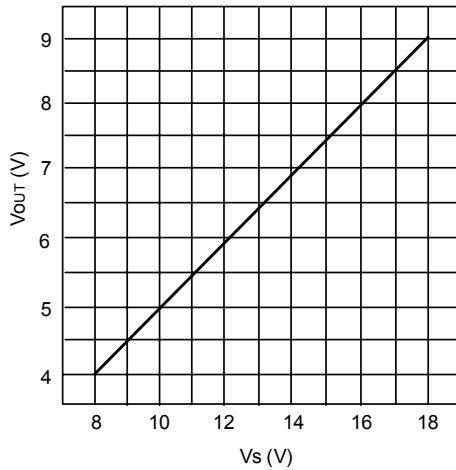

Figure 11. Quiescent Drain Current versus Supply Voltage (Stereo amplifier)

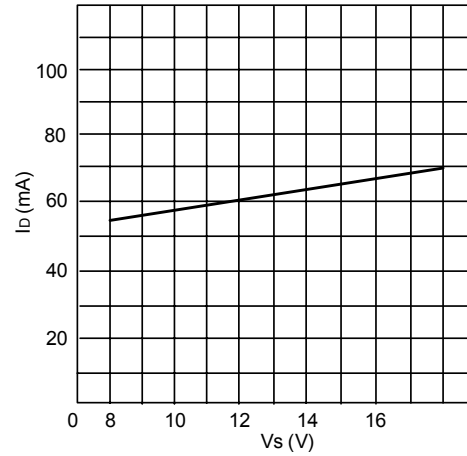

Figure 12. Distortion versus Output Power (Stereo amplifier)

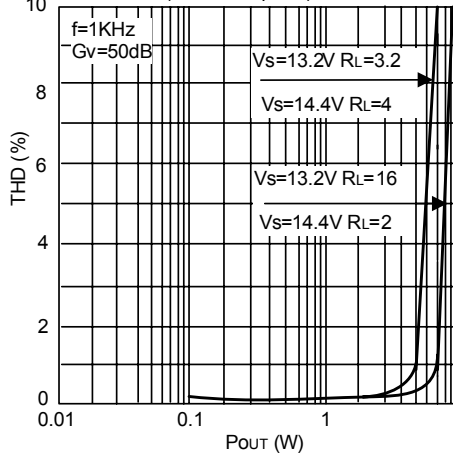

Figure 13. Output Power versus Supply Voltage (Stereo amplifier)

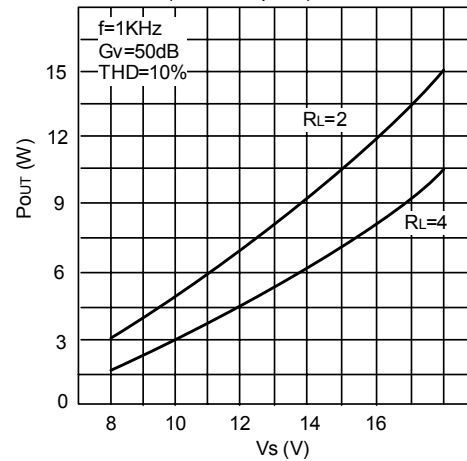

Figure 14. Output Power versus Supply Voltage (Stereo amplifier)

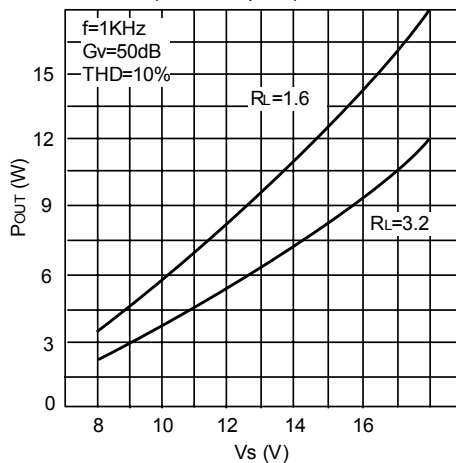
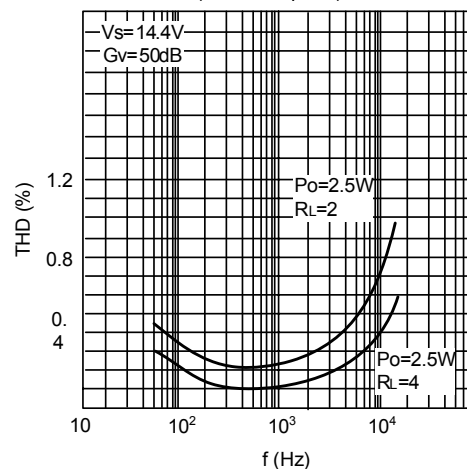

Figure 15. Distortion versus Frequency (Stereo amplifier)



TYPICAL CHARACTERISTICS (cont.)

Figure 16. Distortion versus Frequency (Stereo amplifier)

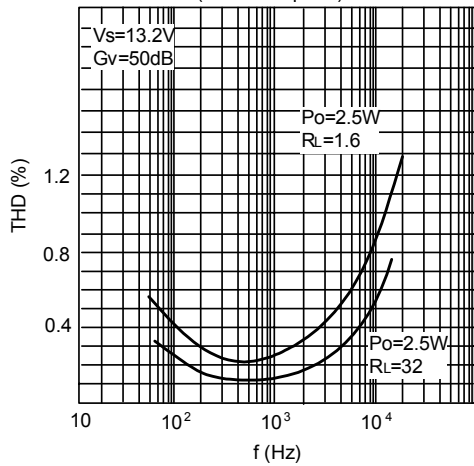

Figure 17. Supply Voltage Rejection versus C3 (Stereo amplifier)

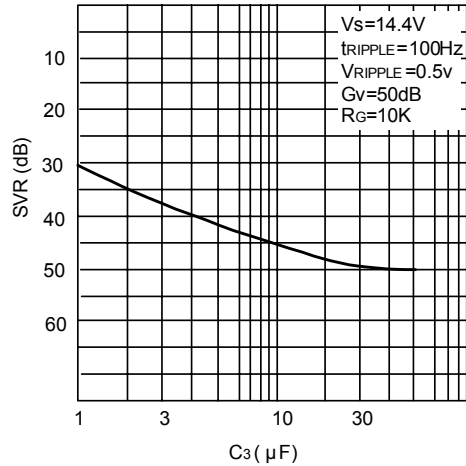

Figure 18. Supply Voltage Rejection versus Frequency (Stereo amplifier)

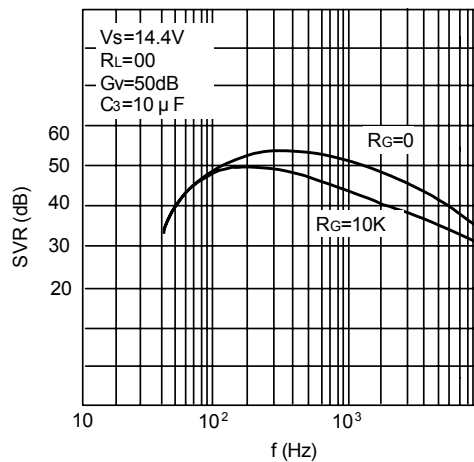

Figure 19. Supply Voltage Rejection versus C2 and C3 (Stereo amplifier)

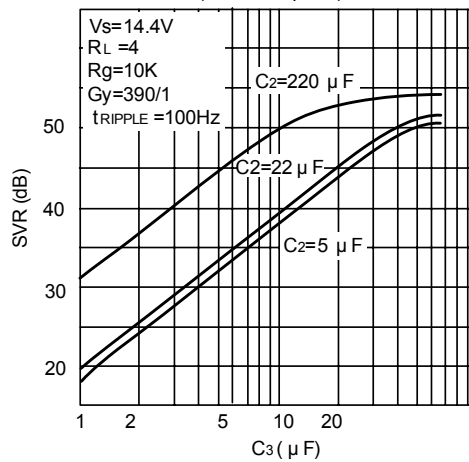

Figure 20. Supply Voltage Rejection versus C2 and C3 (Stereo amplifier)

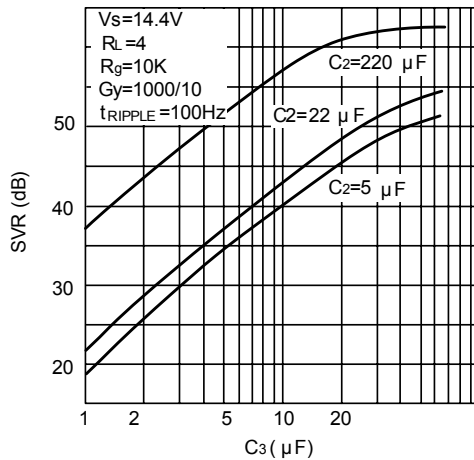
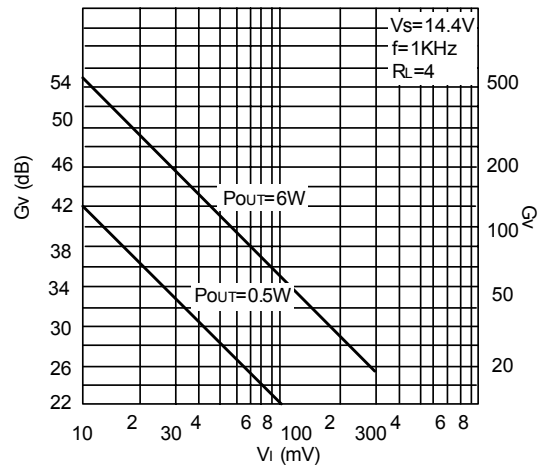

Figure 21. Gain versus Input Sensitivity (Stereo amplifier)



■ TYPICAL CHARACTERISTICS (cont.)

Figure 22. Gain versus Input Sensitivity (Stereo amplifier)

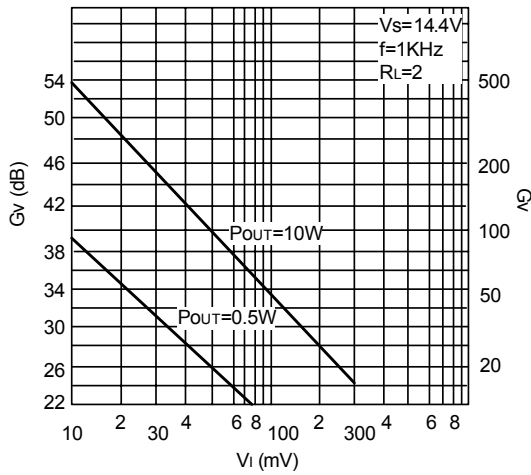

Figure 23. Total Power Dissipation and Efficiency versus Output Power (Bridge amplifier)

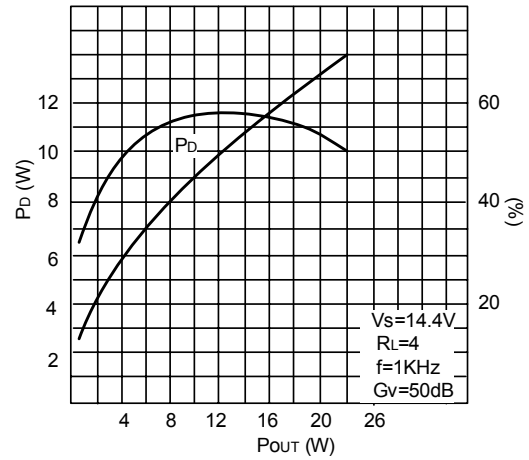
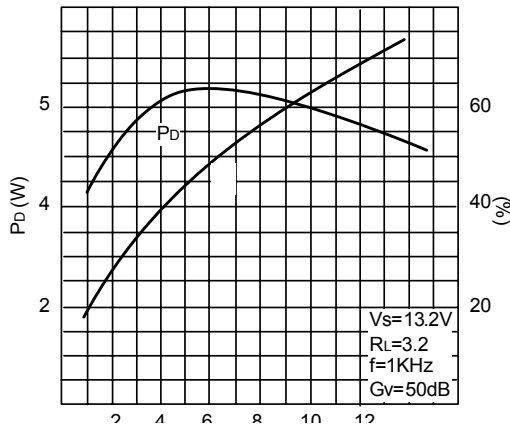

Figure 24. Total Power Dissipation and Efficiency versus Output Power (Stereo amplifier)



UTC assumes no responsibility for equipment failures that result from using products at values that exceed, even momentarily, rated values (such as maximum ratings, operating condition ranges, or other parameters) listed in products specifications of any and all UTC products described or contained herein. UTC products are not designed for use in life support appliances, devices or systems where malfunction of these products can be reasonably expected to result in personal injury. Reproduction in whole or in part is prohibited without the prior written consent of the copyright owner. The information presented in this document does not form part of any quotation or contract, is believed to be accurate and reliable and may be changed without notice.