

Single chip Hi-Fi audio signal processor

BH7802K

The BH7802K incorporates the functions for a VHS audio signal processing system on a single chip. The circuits on the chip are a peak-noise reduction processor (PNR), an FM modulator / demodulator circuit, an I / O switcher, an automatic FM detector circuit, an FM bandpass filter, and a regulator circuit.

●Applications

VCRs

●Features

- 1) Operates off dual \pm power supply which allows a large reduction in the number of coupling capacitors required. A built-in regulator makes it easy to construct a power supply system.
- 2) A two-line I²C bus control decoder circuit is provided, allowing the various IC modes to be set using serial control.
- 3) A four line input switcher is included (tuner, BS, and line 1 / 2). The output switcher can switch between STEREO, LEFT, and RIGHT, and Hi-Fi, MIX, and NORMAL, and a BS MONITOR function is also provided. The MIX AMP is AV-LINK compatible.
- 4) The PNR processor and FM modulator / demodulator circuit have reversed characteristics at recording and playback. In addition, the adjustment for carrier frequency and FM deviation / playback level are common.
- 5) The built-in bandpass filter excels at attenuation of other channels, and can be directly coupled to the playback amplifier. The FM recording output block has a high-performance low-pass filter to produce sine wave output.
- 6) Slope-control-type FM-switching-noise compensation circuit.
- 7) Envelope detector circuit and noise-detector-type automatic FM detector circuit.
- 8) VCO that uses the color signal sub-carrier frequency fsc (NTSC: 3.579545MHz, PAL: 4.433619MHz) and auto-adjusting BPF circuit ensure stable adjustment with no fluctuation due to mounting stress or time.

●Absolute maximum ratings (Ta = 25°C)

Parameter	Symbol	Limits	Unit
Applied voltage	V _{CC}	18, 36pin..... 6.0	V
	V _{EE}	39pin..... - 6.0	V
	V _{IN}	5, 6, 32pin..... 6.5	V
	V _{IN}	Pins other than the above.... 6.0	V
Power dissipation	P _d	850*	mW
Operating temperature	T _{opr}	- 10 ~ + 70	°C
Storage temperature	T _{stg}	- 55 ~ + 125	°C

* Reduced by 8.5mW for each increase in Ta of 1°C over 25°C, when mounted on a 70mm × 70mm, t = 1.6mm glass epoxy board.

●Block diagram

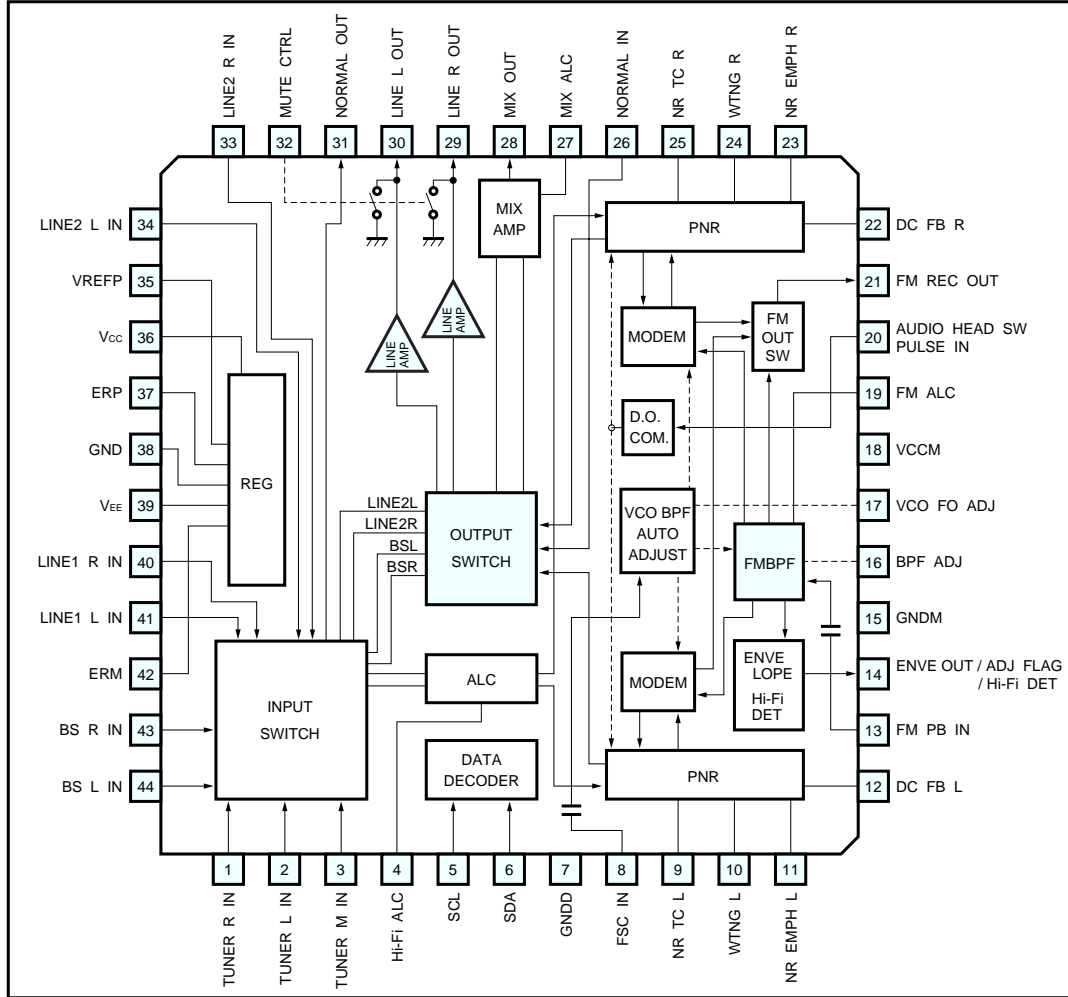

● Pin descriptions

Pin No.	Pin name	Function	Pin voltage	I / O circuit
2, 1, 3	TUNER IN L, R, M	Tuner input (L, R, M)	0.0V	150k Ω
4	Hi-Fi ALC	ALC time constant setting for Hi-Fi audio	0.0V	EF (NPN) ~ 200 Ω
5	SCL	CLOCK input for I ² C bus control	—	B (PNP)
6	SDA	DATA input for I ² C bus control	—	B (PNP)
7	GNDD	GND for serial control	—	—
8	FSC IN	fsc input for VCO and BPF adjustment	0.0V	200k Ω
9, 25	NR TC L, R	PNR attack and recovery time setting. Attack R: 530 Ω , Recovery R: 6.5k Ω	- 5.0V	—
10, 24	WTNG L, R	Waiting characteristic, treble time constant (External C = 0.022 μ F)	0.0V	—
11, 23	NR EMPH L, R	NR emphasis time constant setting (External C = 0.0047 μ F)	0.0V	—
12, 22	DC FB L, R	PNR operating reference potential point	0.0V	11.5k Ω
13	FM PB IN	Playback FM input 660mV _{P-P} Typ. Input coupling capacitor (GND ~ V _{CC})	0.0V	100k Ω
14	ENVE OUT / ADJ FLAG / Hi-Fi DET	FM Lch signal component envelope output / Hi-Fi DET output / ADJ FLAG output for ADJ	EE: 0.8V PB: 1.0V	EE: 50k Ω PB, ADJ: EF (NPN)
15	GNDM	GND for PNR, MODEM and BPF	0.0V	—
16	BPF f ₀ ADJ	Center frequency adjustment for FM BPF	1.9V	EF (NPN) ~ 200 Ω
17	VCO f ₀ ADJ	VCO control current setting	2.5V	EF (NPN)
18	VCCM	V _{CC} for MODEM and BPF	5.0V	—
19	FM ALC	FM ALC time constant setting	0.0V	EF (NPN) ~ 2.5k Ω
20	AHWP IN	Audio head switching pulse input	—	B (PNP)
21	FM REC OUT	EE: recording FM output, sine wave output PB: FM BPF output monitor	EE: 3.3V	EF (NPN) ~ 200 Ω
26	NORMAL IN	Normal input	0.0V	100k Ω
27	MIX ALC	ALC time constant setting for mixer amplifier. Attack and recovery time setting	- 5.0V	EF (NPN) ~ 500 Ω
28	MIX OUT	Mixer amplifier output for RF converter	0.0V	EF (NPN)
30, 29	LINE L, R OUT	Line output	0.0V	330 Ω
31	NORMAL OUT	Normal output	0.0V	EF (P-P)
32	MUTE CTRL	Line output mute control input	—	3k Ω (> 2.5V)
34, 33	LINE2 L, R IN	LINE2 input (L, R)	0.0V	88k Ω
35	VREFP	V _{CC} / 2 reference voltage (power on detect and pre-charge functions)	2.5V	10k Ω
36	VCC	V _{CC} regulator	5.0V	—
37	ERP	V _{CC} regulator error output	5.0V	C (NPN)
38	GND	I / O switch GND	0.0V	—
39	V _{EE}	V _{EE} regulator	- 5.0V	—
41, 40	LINE1 IN L, R	LINE1 input (L, R)	0.0V	88k Ω
42	ERM	V _{EE} regulator error output	- 5.0V	C (PNP)
44, 43	BS IN L, R	BS input (L, R)	0.0V	88k Ω

* I / O circuit; EF: emitter follower, P-P: push pull, B: base, and C: collector.
All numerical values are standardized values.

● Input / output circuits

TUNER L / R / M IN (2, 1, 3pin)

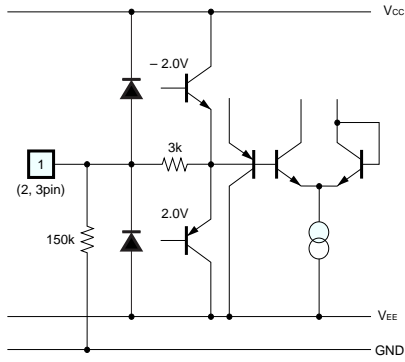

LINE1, LINE2, BS L / R IN (34, 33, 41, 40, 44, 43pin)

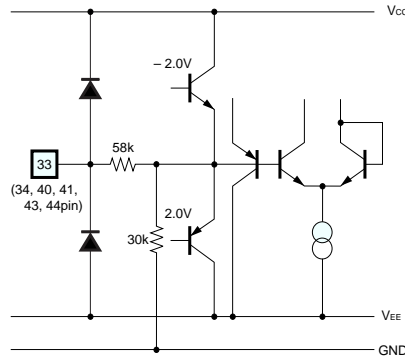

LINE L / R OUT (30, 29pin)

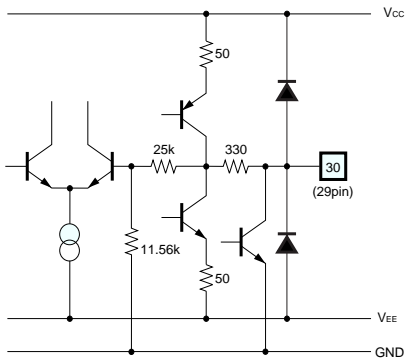

MIX OUT (28pin)

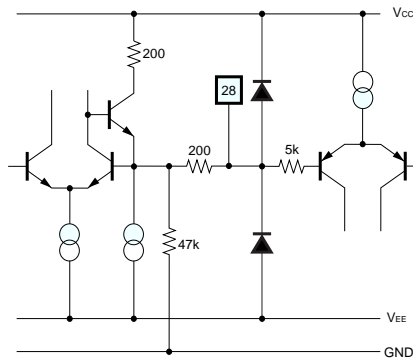

FM REC OUT (21pin)

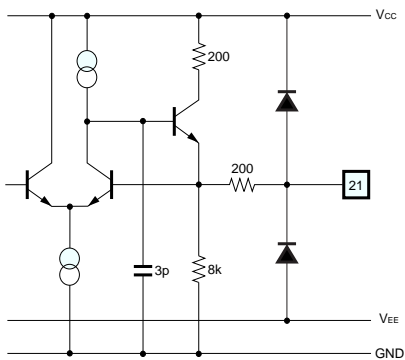

FM PB IN (13pin)

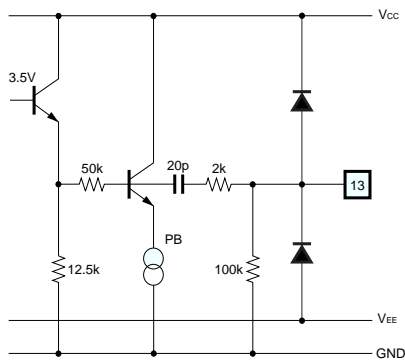

AHSWP IN (20pin)

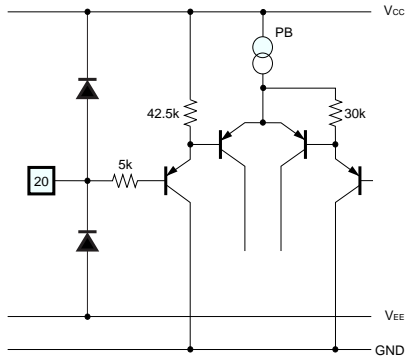

ENVE OUT / ADJ FLAG / Hi-Fi DET (14pin)

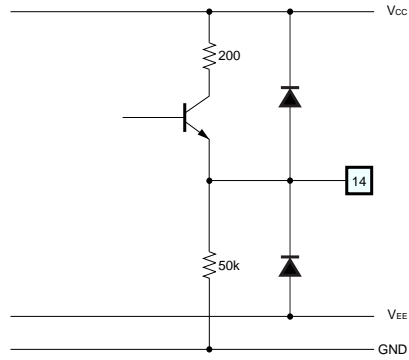

SCL (5pin)

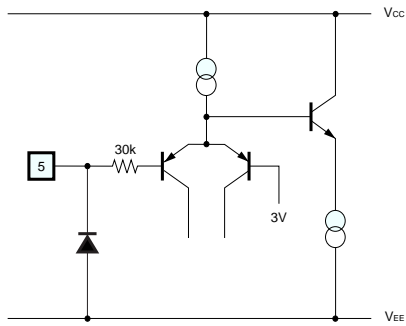

SDA (6pin)

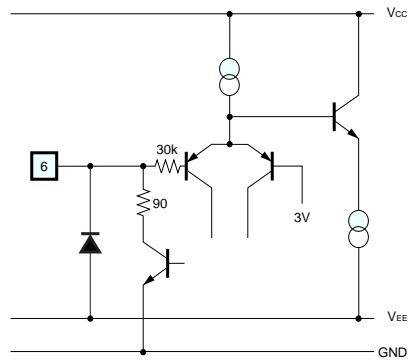

MUTE CTRL (32pin)

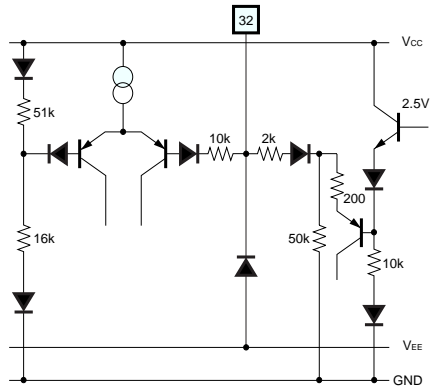

FSC IN (8pin)

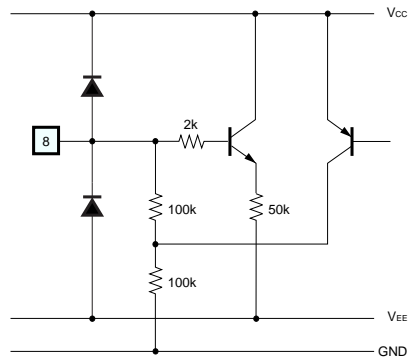

●Electrical characteristics (unless otherwise noted, $T_a = 25^\circ\text{C}$, $\text{UNREG} - V_{\text{CC}} = +10\text{V}$, $\text{UNREG} - V_{\text{EE}} = -10\text{V}$)

• Output switch control (W2D3, W2D4, W2D5)	: STEREO
• BS L2 Through / LINE MUTE control (W2D6, W2D7)	: BS L2 Through / LINE MUTE OFF
• LINE AMP gain control (W2D1, W2D2)	: Typ. (+ 9.8dB)
• FM output control (W1D3)	: FM OUTPUT ON
• FM OUT switch control (W1D4, W1D5, W1D6)	: FM REC output, MIX ratio 1 (- 12.5dB)
• NTSC / PAL control (W1D8)	: NTSC
• Recording MUTE (W1D7)	: Recording <u>MUTE</u>
• Hi-Fi PB MUTE (W2D8)	: OFF
• Normal input switch control (W3D4, W3D5)	: Hi-Fi MIX
• Hi-Fi ALC control (W3D8)	: OFF
• ENVELOPE GAIN (Typ. / 4dB) control (W4D4)	: Typ.
• FM detector level control (W4D1, W4D2)	: Typ.
• ENVE characteristic control (W4D3)	: FNORM detect, no ENVE output
• FM TEST control (W4D6)	: OFF
• FM ALC control (W4D5)	: ALC ON
• MUTE control (pin 32)	: L (MUTE)

Signal frequency $f = 1\text{kHz}$

• INPUT condition 1: TU IN $V_{\text{IN}} = -20\text{dBV}$,	LINE1 / LINE2 / BS $V_{\text{IN}} = -10.2\text{dBV}$
• INPUT condition 2: TU IN $V_{\text{IN}} = -9.8\text{dBV}$,	LINE1 / LINE2 / BS $V_{\text{IN}} = 0.0\text{dBV}$
• INPUT condition 3: TU IN $V_{\text{IN}} = -2.0\text{dBV}$,	LINE1 / LINE2 / BS $V_{\text{IN}} = 8.0\text{dBV}$
MODEM carrier frequency NTSC	Lch 1.30MHz
MODEM carrier frequency NTSC	Rch 1.70MHz
MODEM carrier frequency PAL	Lch 1.40MHz
MODEM carrier frequency PAL	Rch 1.80MHz
fsc NTSC	3.579545MHz
fsc PAL	4.433619MHz

Parameter	Symbol	Min.	Typ.	Max.	Unit	Conditions
<REGULATOR>						
Quiescent current (positive supply) EE	I _{qPEE}	30.0	40.0	53.0	mA	EE MODE, after carrier frequency adjustment with no input
Quiescent current (positive supply) PB	I _{qPPB}	40.0	54.0	72.0	mA	PB MODE, carrier frequency adjustment FNORM, after BPF adjustment
Quiescent current (negative supply) EE	I _{qMEE}	-20.0	-15.0	-11.0	mA	EE MODE, after carrier frequency adjustment with no input
Quiescent current (negative supply) PB	I _{qMPB}	-22.0	-16.0	-12.0	mA	PB MODE, carrier frequency adjustment FNORM, after BPF adjustment
Regulator pin voltage (positive)	V _{CC}	4.75	5.10	5.45	V	—
Regulator pin voltage (negative)	V _{EE}	-5.35	-5.00	-4.65	V	—
<EE THROUGH> (INPUT: TU IN L/R, LINE1 IN L/R, LINE2 IN L/R, BS IN L/R OUTPUT: LINE OUT L/R)						
Line output level	V _{OE}	-11.7	-10.2	-8.7	dBV	INPUT condition 1
Channel balance (L/R)	CB _{EE}	-0.8	0.0	0.8	dB	INPUT condition 1
Distortion	THD _{EE}	—	0.017	0.10	%	INPUT condition 1, *1
Maximum output level	V _{OMEE}	8.3	10.7	—	dBV	THD = 1%, *1
ALC level	V _{ALC}	+2.8	+4.8	+6.8	dBV	INPUT condition 2 ALC ON
ALC distortion	THD _{ALC}	—	0.03	0.25	%	INPUT condition 2, *1 ALC ON
Output residual noise	V _{ONEE}	—	-94.0	-87.0	dBV	Relevant input shorted to GND, *2
Crosstalk	CT _{EE}	—	-88.0	-70.0	dBV	Relevant input: shorted to GND Non-relevant input: Input condition 2, *2
Muting level	MT _{EE}	—	-103	-90	dBV	INPUT condition 2, *2
<INPUT: TU L/R, LINE1 L/R, LINE2 L/R, BS L/R, TU M IN OUTPUT: NORMAL OUT>						
Normal out output level	V _{ONORM}	-21.5	-20.0	-18.5	dBV	INPUT condition 1 L&R input together, *1
<BS / L2 THROUGH> (INPUT: BS / L2 IN L/R OUTPUT: LINE OUT L/R)						
Output level	V _{OBS} V _{OL2}	-11.7	-10.2	-8.7	dBV	V _{IN} = -10.2dBV
Distortion	THD _{BS} THD _{L2}	—	0.005	0.09	%	V _{IN} = -10.2dBV, *1
Output residual noise	V _{ONBS} V _{ONL2}	—	-99.0	-87.0	dBV	BS IN pin shorted to GND, *2
<LINE AMP> (INPUT: NORMAL IN OUTPUT: LINE OUT L/R)						
Line amplifier gain1	V _{OLINE1}	+8.8	+9.8	+10.8	dB	V _{IN} = -20dBV
<MIX AMP> (INPUT: TU IN L/R, LINE1 IN L/R, LINE2 IN L/R, BS IN L/R OUTPUT: MIX OUT)						
Output level	V _{OMIX}	-10.7	-8.7	-6.7	dBV	INPUT condition 1 L&R input together
Distortion	THD _{MIX}	—	0.08	0.50	%	INPUT condition 1 L&R input together, *1
MIX ALC level	V _{ALCMIX}	-4.2	-2.2	-0.2	dBV	INPUT condition 2 L&R input together

*1: B.W. = 0.4 to 30kHz *2: DIN AUDIO

Parameter	Symbol	Min.	Typ.	Max.	Unit	Conditions	
〈OUTPUTSW: HI-FI / NORMAL MIX MODE〉 (INPUT: TU IN L / R, LINE1 IN L / R, LINE2 IN L / R, BS IN L / R, NORMAL IN OUTPUT: LINE OUT)							
Hi-Fi / NORMAL MIX level	V _{HNMIX}	- 11.7	- 10.2	- 8.7	dBV	INPUT condition 1 NORMAL IN: - 20dBV	
〈MODEM REC MODE〉 (INPUT: TUNER IN L / R, LINE1 IN L / R, LINE2 IN L / R, BS IN L / R OUTPUT: FM REC OUT)							
NTSC carrier frequency	Lch	f _{NOL}	1.2905	1.2975	1.3045	MHz	No input, after automatic adjustment
	Rch	f _{NOR}	1.6920	1.6990	1.7060	MHz	
PAL carrier frequency	Lch	f _{POL}	1.3910	1.3980	1.4050	MHz	No input, after automatic adjustment
	Rch	f _{POR}	1.7925	1.7995	1.8065	MHz	
Frequency deviation	Lch	DEV _L	43.0	49.0	55.0	± kHz	INPUT condition 1
	Rch	DEV _R	44.5	50.5	56.5	± kHz	
Maximum frequency deviation	Lch	DEV _{Max.L}	118	140	162	± kHz	INPUT condition 3 (f = 10kHz)
	Rch	DEV _{Max.R}	118	140	162	± kHz	
FM output level	Lch	V _{OFML}	300	355	410	mV _{P-P}	FM OUT SW: FM L mode
	Rch	V _{OFMR}	310	365	420	mV _{P-P}	FM OUT SW: FM R mode
Carrier 2nd harmonic	Lch	f _{2L}	—	- 53.0	- 40.0	dB	Spectrum ratio of 2nd harmonic with respect to fundamental Lch: FM L mode, Rch: FM R mode
	Rch	f _{2R}	—	- 48.0	- 40.0	dB	
Carrier 3rd harmonic	Lch	f _{3L}	—	- 52.0	- 40.0	dB	Spectrum ratio of 3rd harmonic with respect to fundamental Lch: FM L mode, Rch: FM R mode
	Rch	f _{3R}	—	- 55.0	- 40.0	dB	
FM MIX ratio (FM MIX1 mode)	f _{LR}	- 14.5	- 12.5	- 10.5	dB	Spectrum ratio 1.30MHz / 1.70MHz	
〈MODEM PB MODE〉 (INPUT: FM PB IN, OUTPUT: LINE OUT L / R) Carrier setting resistor, after BPF f ₀ adjustmen, V _{IN} = 660mV _{P-P} , 1.30MHz, 1.70MHz MIX IN							
Demodulation output level 1	Lch	V _{ODL}	- 12.7	- 10.2	- 7.7	dBV	DEV _L = ± 50.0kHz, f = 1kHz
	Rch	V _{ODR}	- 12.7	- 10.2	- 7.7	dBV	DEV _R = ± 50.0kHz, f = 1kHz
Demodulation output level 2	Lch	V _{ODL2}	V _{ODL} - 10.0	V _{ODL} - 7.8	V _{ODL} - 5.6	dBV	DEV _L = ± 50.0kHz, f = 10kHz
	Rch	V _{ODR2}	V _{ODR} - 10.0	V _{ODR} - 7.8	V _{ODR} - 5.6	dBV	DEV _R = ± 50.0kHz, f = 10kHz
Demodulation distortion	Lch	THD _{DL}	—	0.12	0.35	%	DEV _L = ± 50.0kHz, f = 1kHz, *1
	Rch	THD _{DR}	—	0.13	0.35	%	DEV _R = ± 50.0kHz, f = 1kHz, *1
Demodulation noise level	Lch	V _{ONDL}	—	- 98.0	- 92.0	dBV	Unmodulated
	Rch	V _{ONDR}	—	- 98.0	- 92.0	dBV	*2
〈Recording→playback overall characteristics〉 (EE---INPUT: LINE IN L / R, OUTPUT: LINE OUT L / R) (PB---INPUT: FM PB IN, OUTPUT: LINE OUT L / R)							
Line output recording / playback level difference	Lch	V _{RPL}	- 1.2	0.0	+ 1.2	dB	Carrier frequency, after adjusting BPF EE mode: INPUT condition 1 PB mode: FM PB IN = 660mV _{P-P} f = 1.30MHz, 1.70MHz 1: 1 MIX, The difference between the EE and PB line out levels when input is DEV = DEV _{L,R} (the frequency deviation given above)
	Rch	V _{RPR}	- 1.2	0.0	+ 1.2	dB	

*1: B.W. = 0.4 to 30kHz

*2: DIN AUDIO

Parameter	Symbol	Min.	Typ.	Max.	Unit	Conditions
〈FM BPF〉 (INPUT: FM PB IN, OUTPUT: BPF MONITOR L / R)						
BPF L / R level difference NTSC	ΔV_{BPFN}	- 5.0	0.0	5.0	dB	After automatic adjustment, NTSC f = 1.505MHz, $V_{IN} = 200mV_{P-P}$
BPF L / R level difference PAL	ΔV_{BPPF}	- 5.0	0.0	5.0	dB	After automatic adjustment, PAL f = 1.605MHz, $V_{IN} = 200mV_{P-P}$
〈Lch, Rch mix input signal level 660mV _{P-P} (RATIO 1: 1)〉						
NTSC Lch						
1.30MHz insertion loss	ATT_{NLC}	- 14.1	- 11.1	- 8.1	dB	1.30MHz + 1.70MHz FM ALC ON
1.15MHz attenuation	ATT_{NL} 1.15	ATT_{NLC} - 9.8	ATT_{NLC} - 5.3	ATT_{NLC} - 2.3	dB	1.15MHz + 1.70MHz
1.45MHz attenuation	ATT_{NL} 1.45	ATT_{NLC} - 8.1	ATT_{NLC} - 5.0	ATT_{NLC} - 2.5	dB	1.45MHz + 1.70MHz
1.70MHz attenuation	ATT_{NL} 1.70	—	—	ATT_{NLC} - 30.0	dB	1.30MHz + 1.70MHz
NTSC Rch						
1.70MHz insertion loss	ATT_{NRC}	- 15.3	- 12.3	- 9.3	dB	1.30MHz + 1.70MHz FM ALC ON
1.55MHz attenuation	ATT_{NR} 1.55	ATT_{NRC} - 8.8	ATT_{NRC} - 5.7	ATT_{NRC} - 3.4	dB	1.55MHz + 1.30MHz
1.85MHz attenuation	ATT_{NR} 1.85	ATT_{NRC} - 9.5	ATT_{NRC} - 4.7	ATT_{NRC} - 1.4	dB	1.85MHz + 1.30MHz
1.30MHz attenuation	ATT_{NR} 1.30	—	—	ATT_{NRC} - 30.0	dB	1.30MHz + 1.70MHz
PAL Lch						
1.40MHz insertion loss	ATT_{PLC}	- 12.9	- 9.9	- 6.9	dB	1.40MHz + 1.80MHz
1.80MHz attenuation	ATT_{PL} 1.80	—	—	ATT_{PLC} - 30.0	dB	1.40MHz + 1.80MHz
PAL Rch						
1.80MHz insertion loss	ATT_{PRC}	- 14.3	- 11.3	- 8.3	dB	1.40MHz + 1.80MHz
1.40MHz attenuation	ATT_{PR} 1.40	—	—	ATT_{PRC} - 30.0	dB	1.40MHz + 1.80MHz
〈FNORM→Hi-Fi recovery delay circuit〉						
Return delay time	T_{FNDLY}	110	125	140	ms	Delay time from input of FM PB IN (1.30MHz, 1.70MHz 1: 1 MIX) 660mV _{P-P} to rise of ENVE OUT AUDIO HEAD PULSE IN : f = 30Hz, 5V _{P-P} , rectangular wave
〈Envelope output circuit〉 (INPUT: FM PB IN, OUTPUT: ENVE OUT) 0dB = 660mV _{P-P} , 1.3MHz&1.70MHz MIX input						
Envelope output level SP0	V_{ENVSP0}	—	0	100	mV	No signal, STANDARD MODE
Envelope output level SP1	V_{ENVSP1}	2.08	2.58	3.08	V	$V_{IN} = 0dB$, STANDARD MODE
Envelope output level SP2	V_{ENVSP2}	3.70	3.95	4.20	V	$V_{IN} = + 10dB$, STANDARD MODE
Envelope output level EP1	V_{ENVEP1}	1.96	2.46	2.96	V	$V_{IN} = - 4dB, + 4dB$ MODE

Parameter	Symbol	Min.	Typ.	Max.	Unit	Conditions
〈Control system mode holding voltage〉						
CLOCK IN						
L mode holding voltage	V _{H5L}	0.0	—	0.5	V	—
H mode holding voltage	V _{H5H}	2.5	—	V _{CC}	V	—
DATA IN						
L mode holding voltage	V _{H6L}	0.0	—	0.5	V	—
H mode holding voltage	V _{H6H}	2.5	—	V _{CC}	V	—
MUTE CTRL						
MUTE holding voltage	V _{H32L}	0.0	—	1.0	V	—
DC MUTE holding voltage	V _{H32H}	3.9	—	V _{CC}	V	—

● Measurement circuit

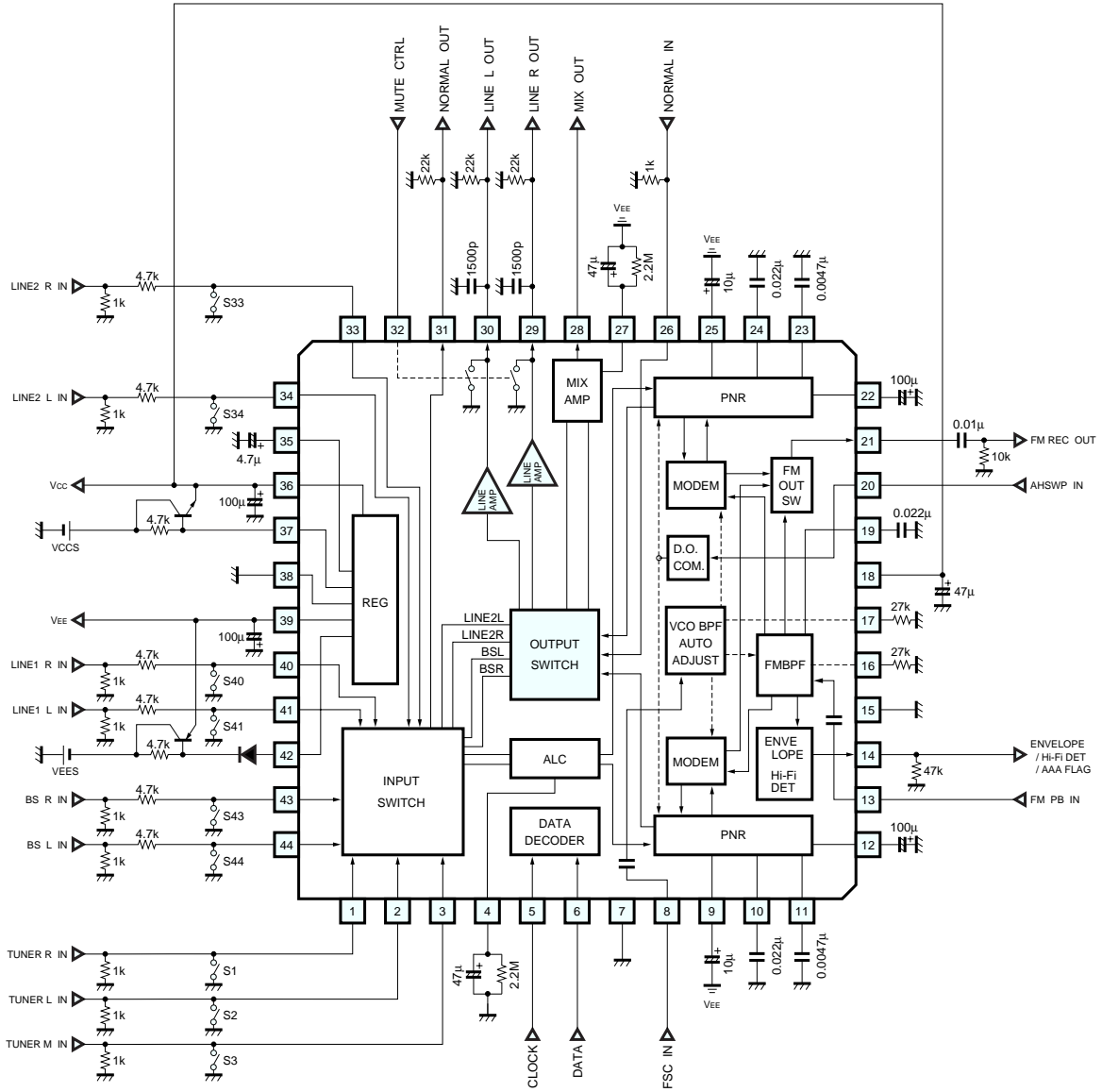

Fig.1

●Circuit operation

Function table

The BH7802K includes the following functions on one chip.

No.	Block name	Main function	Pin number	Power supply
1	Regulator	<ul style="list-style-type: none"> ± 5V regulator (V_{CC}, V_{EE}) Anti-pop circuit (ANTI-POP) 	35 ~ 39, 42	UNREG-V _{CC} : + 10V UNREG-V _{EE} : - 10V GND: 38
2	I ² C BUS control	<ul style="list-style-type: none"> I²C BUS data decoder 	5 ~ 7	V _{CC3} (internal power supply) GND: 7
3	Input switcher	<ul style="list-style-type: none"> TUNER (L, R, M) / LINE 1, 2 (L,R) / BS (L, R) switch 	33, 34, 40, 41 43, 44 1 ~ 3	V _{CC} (internally wired) V _{EE} (internally wired) GND: 38
4	Output switcher	<ul style="list-style-type: none"> Line amplifier: + 9.8dB, + 10.3dB, + 11.3dB, + 15.0dB STEREO / LEFT / RIGHT / 9 NORMAL switch MIX ON / OFF switch Mute switch MIXER amplifier for RF converter (with ALC function) BS / LINE2 through mode 	27 ~ 30 32	V _{CC} (internally wired) V _{EE} (internally wired) GND: 38
6	PNR processor	<ul style="list-style-type: none"> 20kHz line low-pass filter (secondary LPF) 20kHz PNR low-pass filter (secondary LPF) PNR processor (MOA, CCA, WTNG, DET) Emphasis / de-emphasis (EMPH / DEEMPH) Switching noise slope-control type differential compensation circuit 	9 ~ 12 22 ~ 25	V _{CC} (internally wired) V _{EE} (internally wired) GND: 38
7	Modulator	<ul style="list-style-type: none"> FM modulation circuit (VCO, DEV) FM demodulation / FM BPF MONITOR output switch (FMOUT SW) : FM MIX1 to 4, FM L, FM R, BPF L, BPF R Recording FM treble cutoff filter (FM LPF) Over modulation limiter (AUDIO LIM) Playback FM limiter (FM LIM) VCO, BPF automatic adjustment circuit (AUTO AUDIO ADJUST) NTSC / PAL switch function Auto adjustment complete FLAG output circuit (ADJ FLAG) 	8, 14 17, 21	V _{CC} : 18 V _{EE} (internally wired) GND: 15
8	FM detector control	<ul style="list-style-type: none"> D.O.detector circuit (D.O. DET) Auto FM detector circuit (noise detect method) (FM DET) : Typ, + 10%, - 10% Envelope detector circuit (ENVE) Hold pulse generator 	14, 20	V _{CC} : 18 (internally wired) GND: 15
9	FM BPF	<ul style="list-style-type: none"> FM bandpass filter (FM BPF) NTSC / PAL switch function FM input automatic level adjust circuit (FM ALC: ON / OFF) 	13, 16, 19	V _{CC} : 18 GND: 15

●Application example

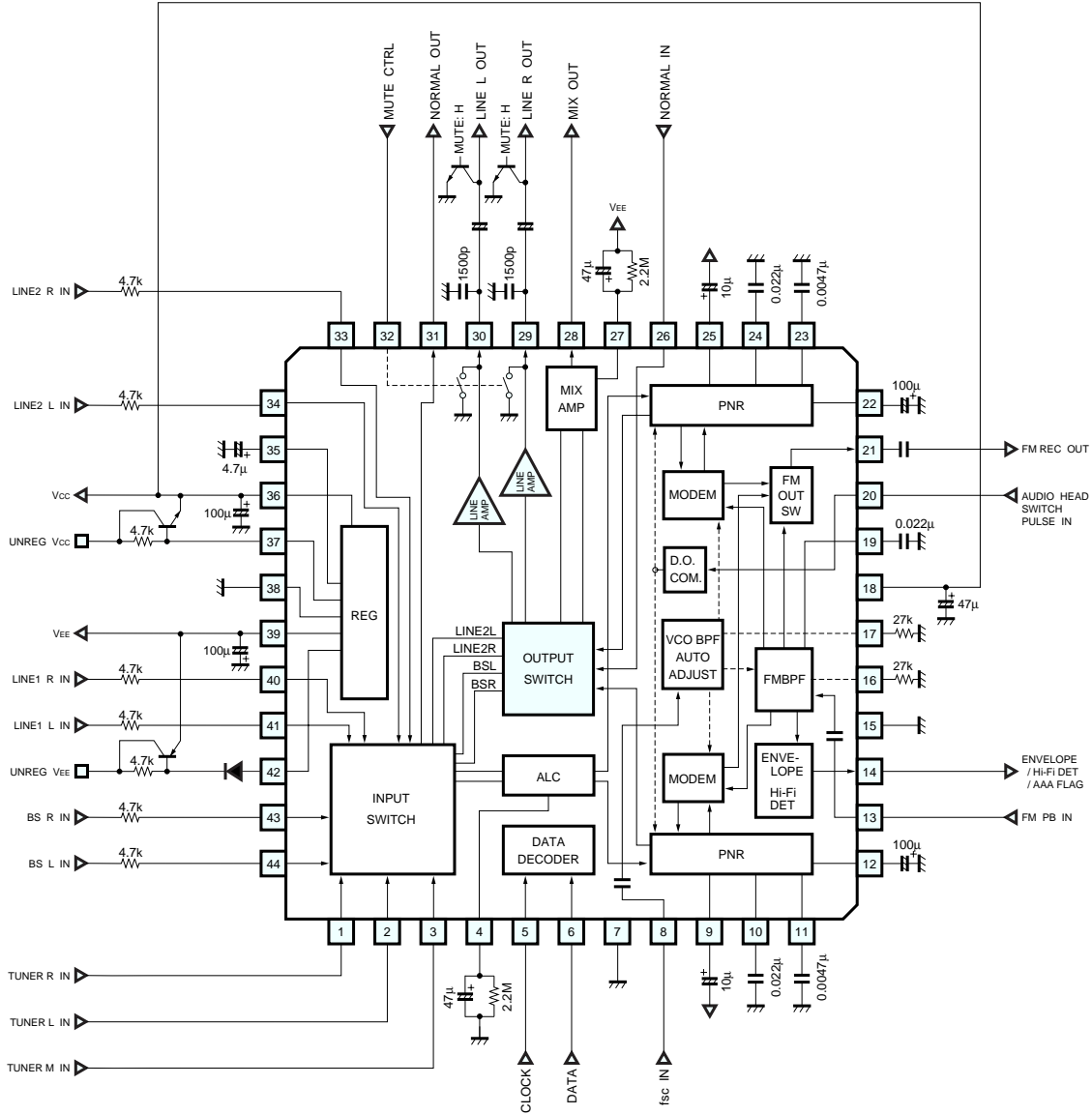

Fig.2

●Operation notes

The VCO oscillation frequency and frequency deviation, and the BPF center frequency are directly influenced by the temperature characteristics of the setting resistors connected to pins 16 and 17. Use metal-film components.

●Electrical characteristic curves

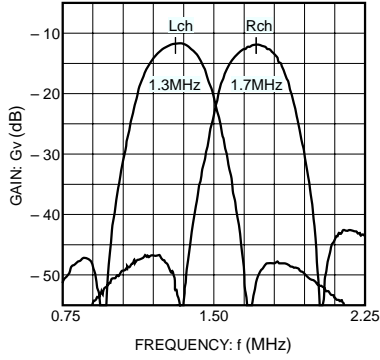

Fig. 3 FM BPF frequency characteristics (NTSC)

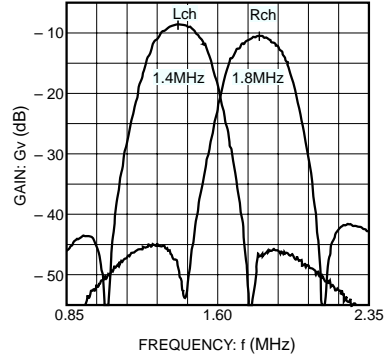

Fig. 4 FM BPF frequency characteristics (PAL)

●External dimensions (Units: mm)

