

AN5265

TV Sound Output Circuit

■ Overview

The AN5265 is a semiconductor integrated circuit designed for TV sound output circuit.

■ Features

- DC volume adjustment method employed. Controlled with DC voltage.
- Fin-attached 9-lead SIP package employed

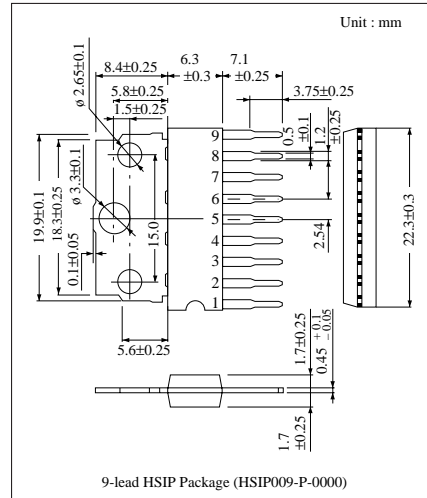

■ Pin Descriptions

Pin No.	Pin Description
1	Supply Voltage 1
2	Sound Input
3	Mute
4	Volume adjustment
5	Filter
6	Feedback
7	GND
8	Sound output
9	Supply voltage 2

■ Block Diagram

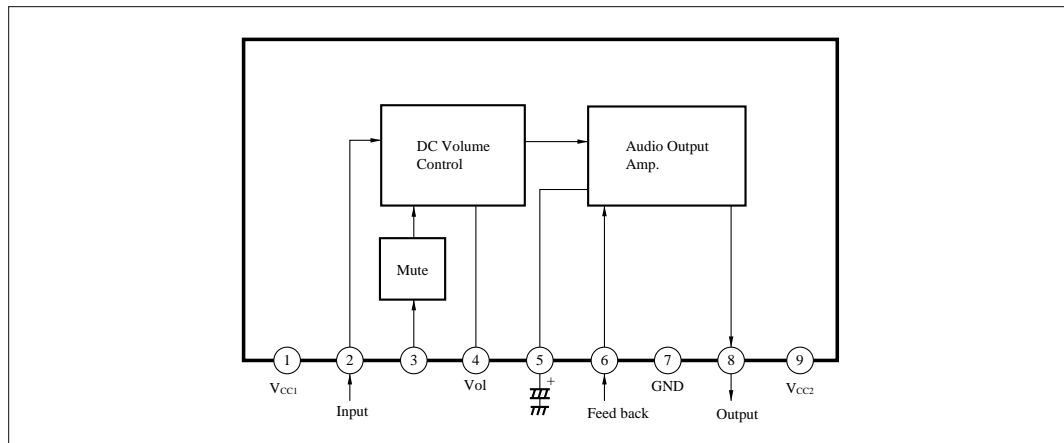

■ Absolute Maximum Ratings (Ta= 25°C)

Parameter	Symbol	Rating		Unit	
Voltage	Supply Voltage	V ₁₋₇	14.4		V
		V ₉₋₇	26		V
	Circuit Voltage	V ₃₋₇	0	7	V
		V ₄₋₇	0	V ₁₋₇	V
		V ₆₋₇	0	V ₉₋₇	V
Current	Circuit Current	I ₄	-10	3	mA (peak)
		I ₈	-1.2	1.2	A (peak)
Power Dissipation	P _D	1.6		W	
Operating Ambient Temperature	T _{opr}	- 20 ~ + 70		°C	
Storage Temperature	T _{stg}	- 55 ~ + 150		°C	

■ Electrical Characteristics (Ta= 25°C)

Parameter	Symbol	Condition	min.	typ.	max.	Unit
Circuit Current	I _I	Pin1= Pin4 = 12V, Pin7= 0V, Pin9 = 18V	7.1	9.5	11.9	mA
Circuit Voltage	V ₂₋₇	Pin1= 12V, Pin4 = Pin7= 0V, Pin9 = 18V	—	5.4	—	V
Circuit Voltage	V ₅₋₇	Pin1= 12V, Pin4 = Pin7= 0V, Pin9 = 18V	—	8.5	—	V
Circuit Voltage	V ₆₋₇	Pin1= 12V, Pin4 = Pin7= 0V, Pin9 = 18V	—	8.8	—	V
Circuit Voltage	V ₈₋₇	Pin1= 12V, Pin4= Pin7= 0V, Pin9=18V, Pin6-8: 10kΩ	—	8.8	—	V
Max. Output Power	P _{Omax.}	f= 1kHz, THD= 10%, V ₄ = 12V, R _L = 16Ω	2.0	2.3	—	W
Voltage Gain	G _V	f= 1kHz, V _i = 0.1Vrms, V ₄ = 12V	28.5	30.5	32.5	dB
Total Harmonics Distortion	THD	f= 1kHz, P _O = 1W, V ₄ = 12V	—	0.8	1.2	%
Max. Attenuation Amount	A _{att}	f= 1kHz, V _i = 0.1Vrms, V ₄ = Ratio between 12 and 0 V	—	-95	-85	dB
Output Noise Voltage	V _{no}	V _i = 0Vrms, V ₄ = 0V	—	0.6	1.0	mVrms
Muting Operation Voltage	V ₃₋₇	f= 1kHz, V ₄ = 12V, V ₈ = 0Vrms	2.45	2.65	2.85	V

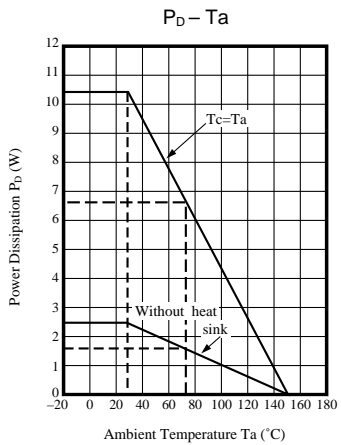

■ Application Circuit

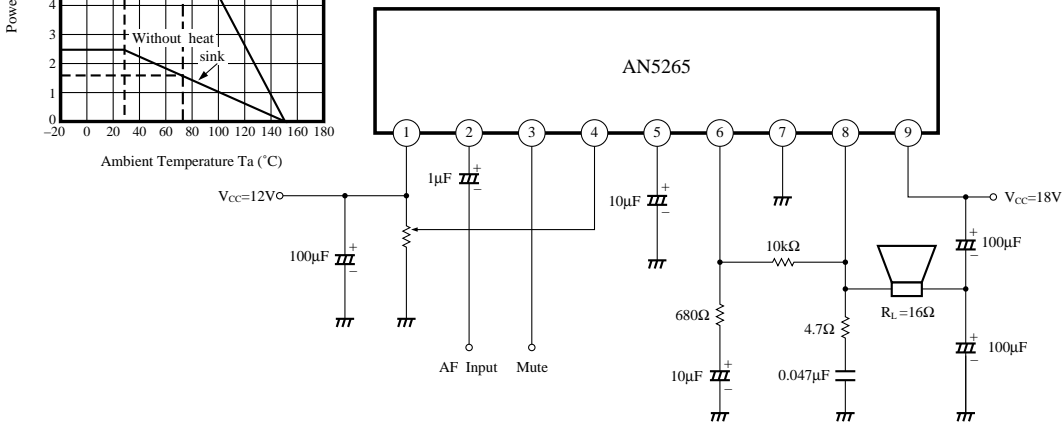

Panasonic