

AN7117

Low Power Consumption 1W Audio Power Amplifier

■ Description

The AN7117 is a monolithic integrated circuit designed for low power consumption 1W audio power amplifier.

■ Features

- Low quiescent current: $I_{CQ} = 8\text{mA typ.}$ (at $V_{CC} = 6\text{V}$, $R_L = 4\Omega$)
- Low voltage operation: $V_{CC} = 2.0\text{V} \sim 9.0\text{V}$

■ Pin

Pin No.	Pin Name
1	Output
2	GND
3	Ripple Filter
4	N.F.B.
5	Input
6	Ripple Filter
7	Phase Compensation
8	Phase Compensation
9	V_{CC}

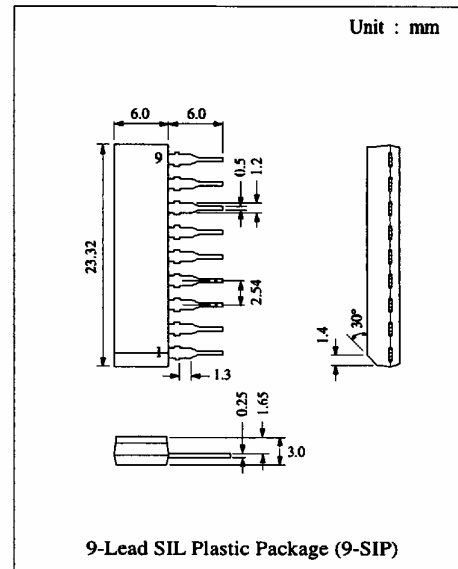

■ Block Diagram

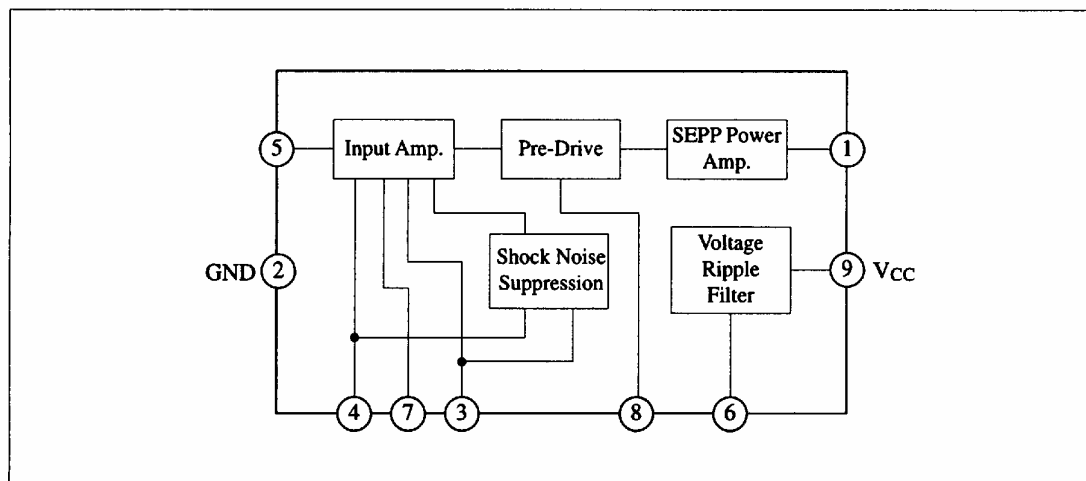

■ Absolute Maximum Ratings (Ta=25°C)

Item	Symbol	Rating	Unit
Supply Voltage	V _{CC}	9	V
Supply Current	I _{CC(peak)}	2	A
Power Dissipation	P _D	1	W
Operating Ambient Temperature	Topr	-20 ~ +75	°C
Storage Temperature	Tstg	-50 ~ +150	°C

Operating Supply Voltage Range: V_{CC} = 2.0V ~ 9.0V

■ Electrical Characteristics (V_{CC}=6V, R_L=4Ω, f=1kHz, Ta=25°C)

Item	Symbol	Condition	min.	typ.	max.	Unit
Quiescent Current	I _{CQ}	V _{in} = 0mV		8	16	mA
Voltage Gain	G _v	V _{in} = 3mV	37.5	39.5	41.5	dB
Output Power	P _O	THD = 10%	550	650		mW
Output Power	P _O	R _L = 8Ω, THD = 10%		440		mW
Total Harmonic Distortion	THD	V _{in} = 2mV		0.6	1.5	%
Output Noise Voltage	V _{no}	R _g = 10kΩ		0.2	1.0	mV
Input Resistance	R _{in}			30		kΩ
Ripple Rejection	RR	V _{CC} = 6V ± 400mV	35	45		dB

Test Circuit

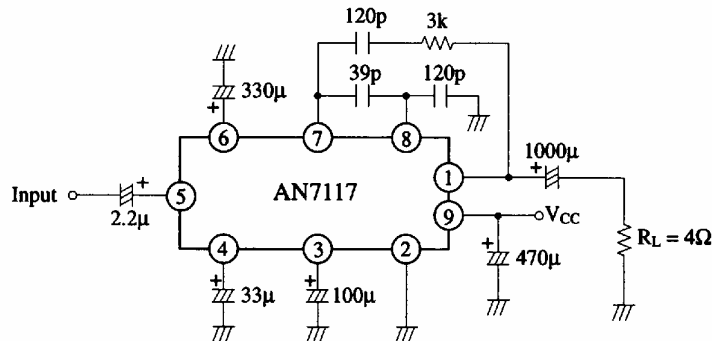

■ Application Circuit

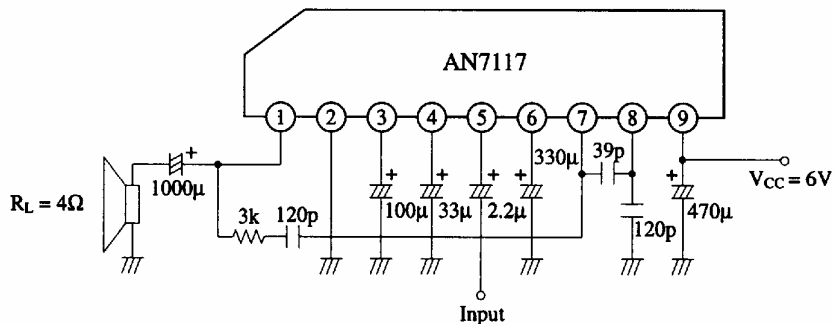

■ Characteristics Curve

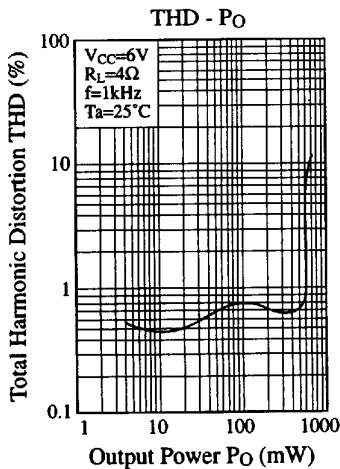
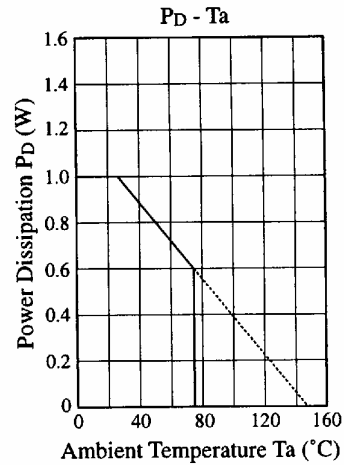
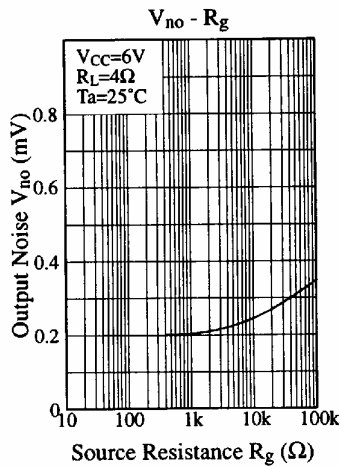
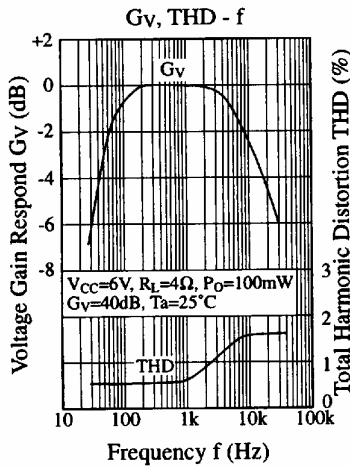
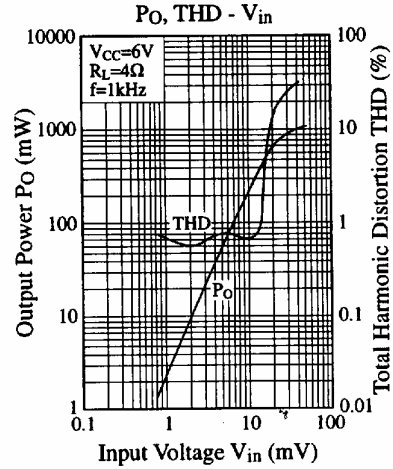
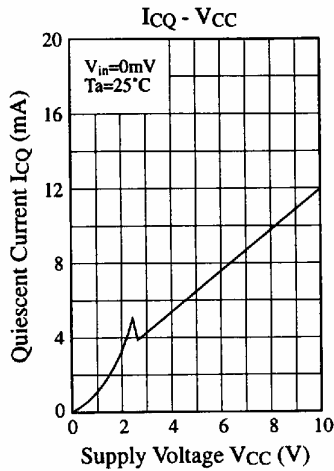
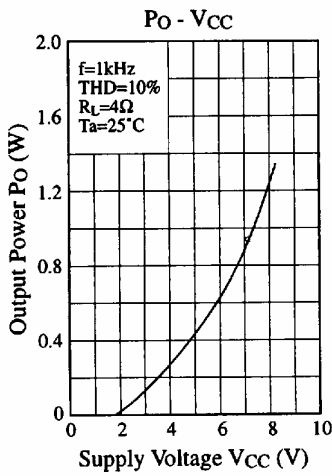

■ Printed Circuit Board Layout (Scale: 1:1)

