

AN7142

0.9W Dual Audio Power Amplifier

■ Description

The AN7142 is a monolithic integrated circuit designed for dual audio power amplifiers in consumer applications. It is suitable for portable stereo radio/cassette recorders.

■ Features

- Wide operating voltage range: $V_{CC} = 3.9V \sim 18V$
- Dual channel operation in a single DIP package
- Large maximum output power: $P_O = 0.9W$ at $V_{CC} = 6V, R_L = 4\Omega$

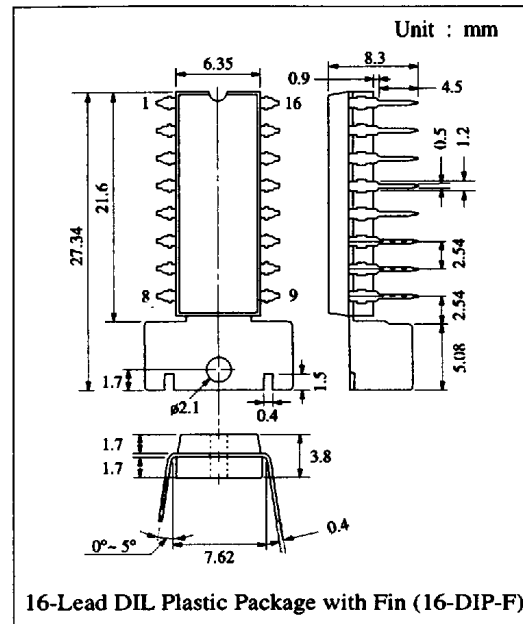

■ Pin

Pin No	Pin Name	Pin No	Pin Name
1	GND (Input)	9	GND (Output) Ch.2
2	Negative Feedback Ch.1	10	Output Ch.2
3	Input Ch.1	11	VCC
4	Crossover Distortion Suppression Ch.1	12	Bootstrap Ch.2
5	Bootstrap Ch.1	13	Crossover Distortion Suppression Ch.2
6	N.C.	14	Input Ch.2
7	Output Ch.1	15	Negative Feedback Ch.2
8	GND (Output) Ch.1	16	Ripple Filter

■ Block Diagram

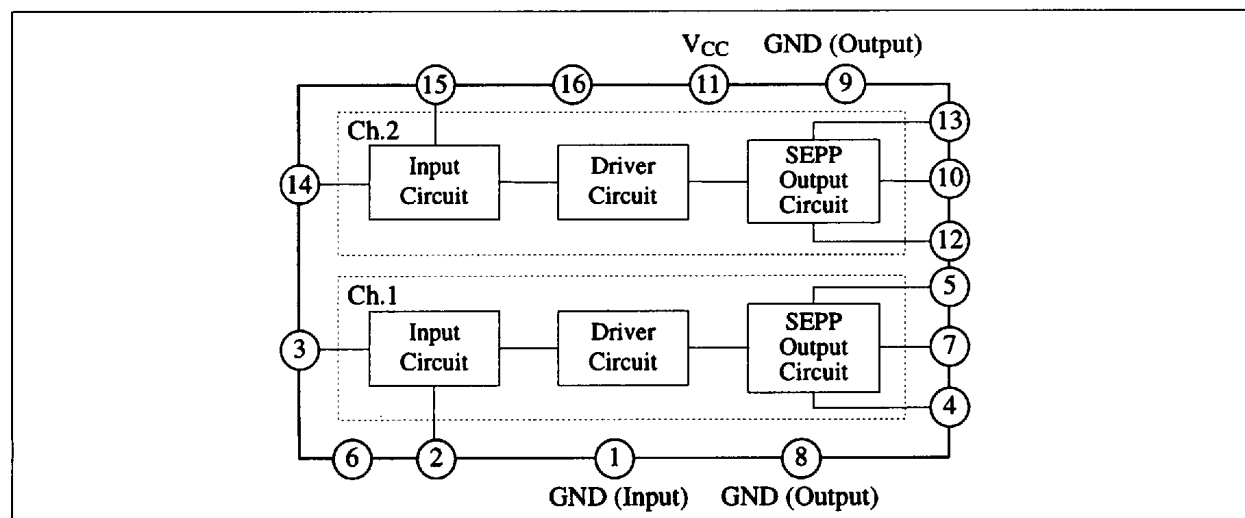

■ Absolute Maximum Ratings (Ta=25°C)

Item	Symbol	Rating	Unit
Supply Voltage	V _{CC}	18	V
Supply Current	I _{CC}	4	A
Power Dissipation	P _D	8.3	W
Operating Ambient Temperature	Topr	-30 ~ +75	°C
Storage Temperature	Tstg	-55 ~ +150	°C

Operating Supply Voltage Range: V_{CC} = 3.9V ~ 18V

■ Electrical Characteristics (V_{CC}=6V, R_L=4Ω, f=1kHz, Ta=25°C)

Item	Symbol	Condition	min.	typ.	max.	Unit
Quiescent Current	I _{CQ}	V _{in} = 0mV	9	14	21	mA
Output Noise Voltage	V _{no}	V _{in} = 0mV, R _g = 10kΩ, With filter 15~30kHz (12dB/OCT)		0.3	0.5	mV
Voltage Gain	G _V	V _O = 0.5V	41.5	43.5	45.5	dB
Total Harmonic Distortion	THD	V _O = 0.5V		0.6	1.1	%
Maximum Output Power	P _{O(max)}	THD = 10%	0.7	0.9		W
Channel Balance	CB	V _O = 0.5V			1	dB

■ Application Circuit

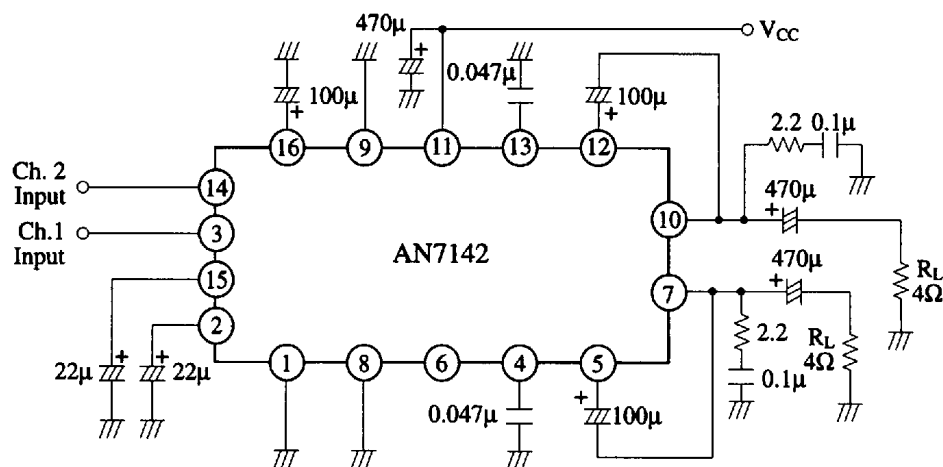

■ Characteristics Curve

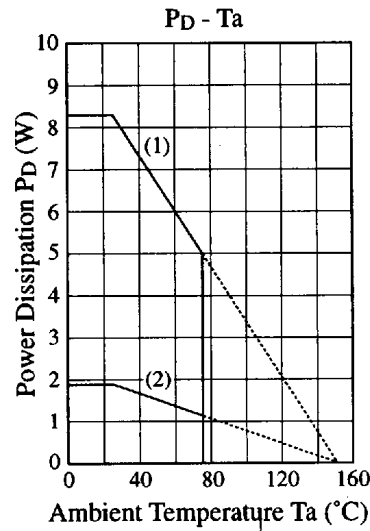
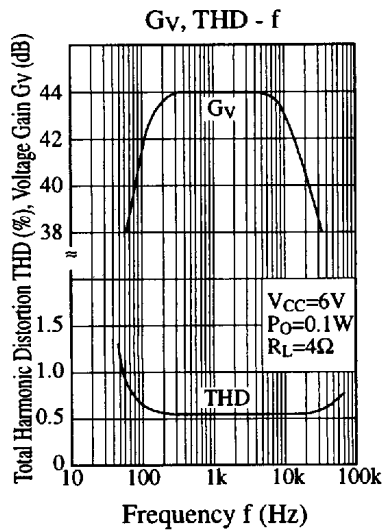
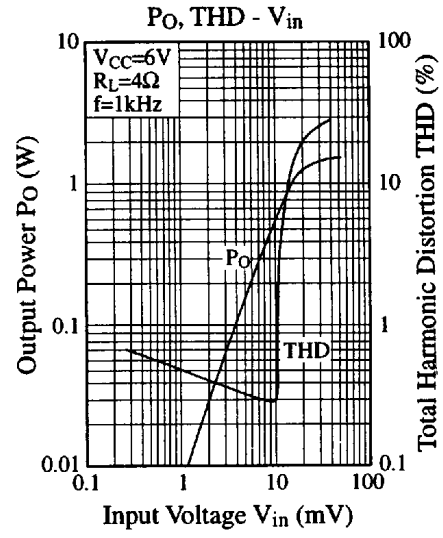
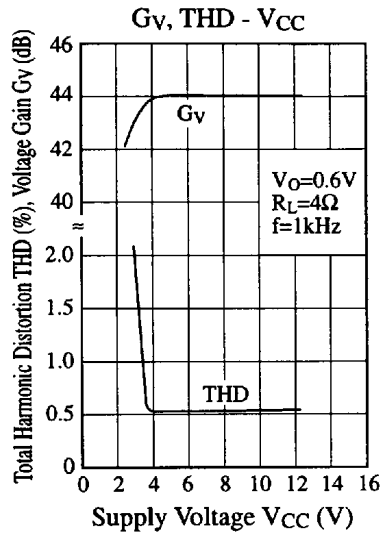
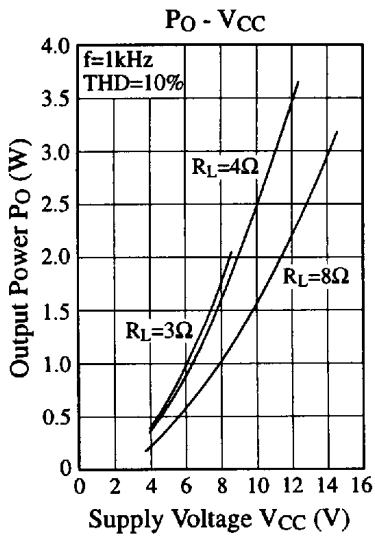

- (1) 8.33W With ∞ heat sink (θ_{j-a}=15°C/W)
- (2) 1.87W Without heat sink (θ_{j-a}=67°C/W)

■ Printed Circuit Board Layout (Scale: 1:1)

