

# AN7195Z

## Dual 15 W BTL power IC for car audio

### ■ Overview

The AN7195Z is an audio power IC developed for the sound output of car audio (dual 15 W).

It is incorporating various protection circuits to protect the IC from destruction by GND-open short-circuit to GND and power supply surge which are the most important subjects of power IC protection, and the IC will largely contribute to a high reliability design of equipment.

It is also incorporating the industry's first excellent muting circuit, which is free from shock noise, so that a shock noise design under the set transient condition can be made easily when the muting circuit is used together with its standby function.

In addition, the AN7195Z is pin compatible with the AN7136Z (dual 20 W), so that the identical pattern design is allowed for high-class types as well as popular types.

### ■ Features

- Built-in various protection circuits (realizing high break-down voltage against destruction )
  - Power supply surge breakdown voltage of 100 V or more
  - Ground-open breakdown voltage of 14 V or more
- Built-in standby function (free from shock noise at standby on/off)
- Built-in muting function
  - Free from shock noise at mute-on/off
  - Adapting attenuator method so that abnormal sound due to waveform deformation is not generated
  - Attack time, recovery time of 50 ms or less
- Reduction in external components (parts reduction to half compared with the AN7176K)
  - It eliminates the need for NF and BS electrolytic capacitors,
  - Muting function is unnecessary
  - Power supply choke coil is unnecessary
- Provided with beep sound input pin
- High sound quality design
- Pin compatible with the AN7136Z (dual 20 W)

### ■ Applications

- Car audio

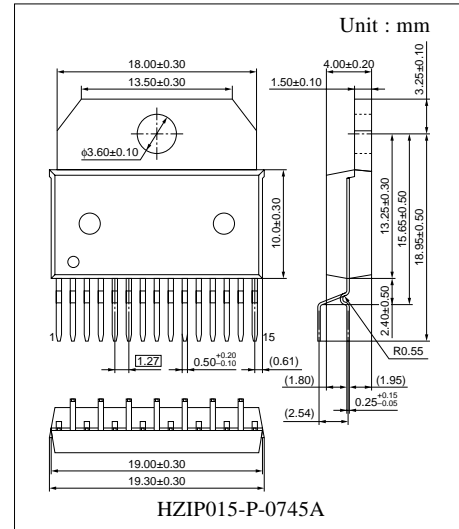

### ■ Block Diagram

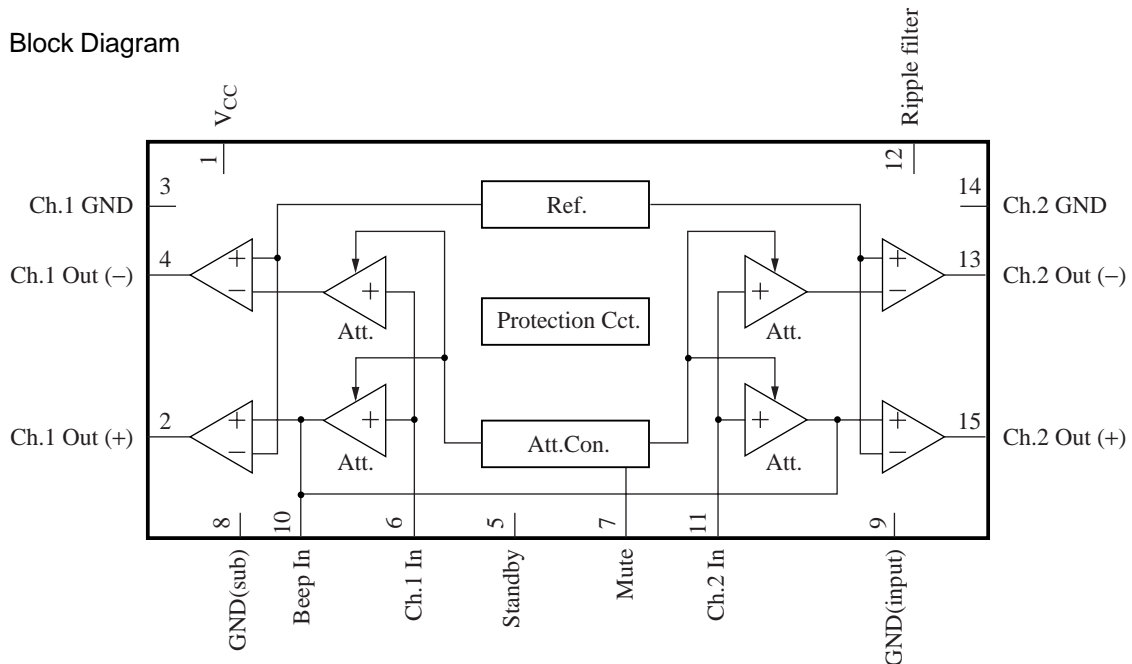

### ■ Pin Descriptions

Pin No.	Description	Pin No.	Description
1	Power supply	9	Grounding (input)
2	Ch.1 output (+)	10	Beep sound input
3	Grounding (output ch.1)	11	Ch.2 input
4	Ch.1 output (-)	12	Ripple filter
5	Standby	13	Ch.2 output (-)
6	Ch.1 input	14	Grounding (output ch.2)
7	Muting	15	Ch.2 output (+)
8	Grounding (sub)		

### ■ Absolute Maximum Ratings

Parameter	Symbol	Rating	Unit
Supply voltage <sup>*2</sup>	V <sub>CC</sub>	25	V
Peak supply voltage <sup>*3</sup>	V <sub>surge</sub>	80	V
Supply current	I <sub>CC</sub>	9.0	A
Power dissipation <sup>*4</sup>	P <sub>D</sub>	32.5	W
Operating ambient temperature <sup>*1</sup>	T <sub>opr</sub>	-30 to +85	°C
Storage temperature <sup>*1</sup>	T <sub>stg</sub>	-55 to +150	°C

Note) \*1 : All items are at T<sub>a</sub> = 25°C, except for the operating ambient temperature and storage temperature.

\*2 : Without signal

\*3 : Time = 0.2 s

\*4 : T<sub>a</sub> = 85°C

### ■ Recommended Operating Range

Parameter	Symbol	Range	Unit
Supply voltage	$V_{CC}$	8.0 to 18.0	V

### ■ Electrical Characteristics at $V_{CC} = 13.2$ V, $f = 1$ kHz, $T_a = 25^\circ\text{C}$

Parameter	Symbol	Conditions	Min	Typ	Max	Unit
Quiescent current	$I_{CQ}$	$V_{IN} = 0$ mV, $R_L = 4 \Omega$	—	120	250	mA
Standby current	$I_{STB}$	$V_{IN} = 0$ mV, $R_L = 4 \Omega$	—	1	10	$\mu\text{A}$
Output noise voltage <sup>*1</sup>	$V_{NO}$	$R_g = 4.7$ k $\Omega$ , $R_L = 4 \Omega$	—	0.22	0.5	mV[rms]
Voltage gain 1	$G_{V1}$	$V_{IN} = 20$ mV, $R_L = 4 \Omega$	38	40	42	dB
Total harmonic distortion 1	$THD_1$	$V_{IN} = 20$ mV, $R_L = 4 \Omega$	—	0.07	0.4	%
Maximum output power 1	$P_{O1}$	$THD = 10\%$ , $R_L = 4 \Omega$	12	14	—	W
Ripple rejection ratio <sup>*1</sup>	RR	$R_L = 4 \Omega$ , $R_g = 4.7$ k $\Omega$ , $V_r = 1$ V[rms], $f_r = 1$ kHz	60	70	—	dB
Channel balance	CB	$V_{IN} = 20$ mV, $R_L = 4 \Omega$	—	0	1	dB
Cross-talk <sup>*1</sup>	CT	$V_{IN} = 20$ mV, $R_L = 4 \Omega$ , $R_g = 4.7$ k $\Omega$	55	65	—	dB
Output offset voltage	$V_{Off}$	$R_g = 4.7$ k $\Omega$ , $R_L = 4 \Omega$	-300	0	300	mV
Muting effect <sup>*1</sup>	MT	$V_{IN} = 20$ mV, $R_L = 4 \Omega$	70	82	—	dB
Input impedance	$Z_i$	$V_{IN} = \pm 0.3$ V <sub>DC</sub>	22	30	35	k $\Omega$
Voltage gain 2	$G_{V2}$	$V_{IN} = 20$ mV, $R_L = 2 \Omega$	38	40	42	dB
Total harmonic distortion 2	$THD_2$	$V_{IN} = 20$ mV, $R_L = 2 \Omega$	—	0.1	0.5	%
Maximum output power 2	$P_{O2}$	$THD = 10\%$ , $R_L = 2 \Omega$	12	20	—	W
Shock noise <sup>*2</sup>	$V_S$	$R_L = 4 \Omega$ , $R_g = 4.7$ k $\Omega$ $V_{STB} = \text{on/off}$ , 50 Hz HPF-on	-100	0	100	mV[p-0]
Total harmonic distortion 3	$THD_3$	$V_{IN} = 10$ mV, $f_{IN} = 20$ kHz $R_g = 4.7$ k $\Omega$ , $R_L = \infty$	—	0.10	0.5	%

Note) \*1 : Measurement using a bandwidth 15 Hz to 30 kHz (12 dB/OCT) filter.

\*2 : For  $V_{STB} = \text{on/off}$ , change over the standby terminal by the voltages of 0 V and 5 V at the time shown below.

Standby terminal voltage

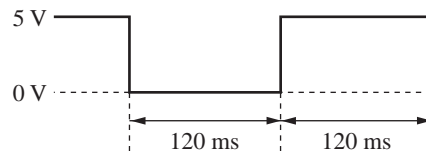

■ Terminal Equivalent Circuits

Pin No.	Equivalent circuit	Description	DC Voltage
1	—	Supply voltage pin Supply connection pin	13.2 V
2		Ch.1 output pin (+) Ch.1 positive-phase output pin	6.6 V
3	—	GND (output) Grounding pin for ch.1 output	0 V
4		Ch.1 output pin (-) Ch.1 inverted-phase output pin	6.6 V
5		Standby control pin Standby changeover pin Threshold voltage approx. 2.1 V	—
6		Ch.1 input pin Ch.1 input signal applied pin Input impedance 30 kΩ	0 mV to 10 mV

■ Terminal Equivalent Circuits (continued)

Pin No.	Equivalent circuit	Description	DC Voltage
7		Mute control pin  Mute changeover pin Threshold voltage approx. 2.0 V	—
8	—	GND (substrate)  Being connected with substrate only	0 V
9	—	GND (input)  Ground pin for input	0 V
10		Beep sound input pin  Beep sound signal input pin Input impedance 25 kΩ	2.1 V
11		Ch.2 input pin  Ch. 2 input signal applied pin Input impedance 30 kΩ	0 mV to 10 mV
12		Ripple filter pin  Output current 3 mA to 10 mA	13.0 V

### ■ Terminal Equivalent Circuits (continued)

Pin No.	Equivalent circuit	Description	DC Voltage
13		Ch.2 output pin (-) Ch.2 inverted-phase output pin	6.6 V
14	—	GND(output) Grounding pin for ch.2 output	0 V
15		Ch.2 Output pin (+) Ch.2 positive-phase output pin	6.6 V

### ■ Usage Notes

1. Always attach an outside heat sink to use the chip. In addition, the outside heat sink must be fastened onto a chassis for use.
2. Connect the cooling fin to GND potential.
3. Avoid short-circuit to  $V_{CC}$  and short-circuit to GND, and load short-circuit.
4. The temperature protection circuit will be actuated at  $T_j = \text{approx. } 150^\circ\text{C}$ , but it is automatically reset when the chip temperature drops below the above set level.
5. The overvoltage protection circuit starts its operation at  $V_{CC} = \text{approx. } 20 \text{ V}$ .
6. Take into consideration the heat radiation design particularly when  $V_{CC}$  is set high or when the load is  $2 \Omega$ .
7. When the beep sound function is not used, open the beep sound input pin (pin 10) or connect it to pin 9 with around  $0.01 \mu\text{F}$  capacitor.
8. Connect only pin 9 (ground, signal source) to the signal GND of the amplifier in the previous stage. The characteristics such as distortion, etc. will be improved.

■ Technical Information

[1]  $P_D - T_a$  curves of HZIP015-P-0745A

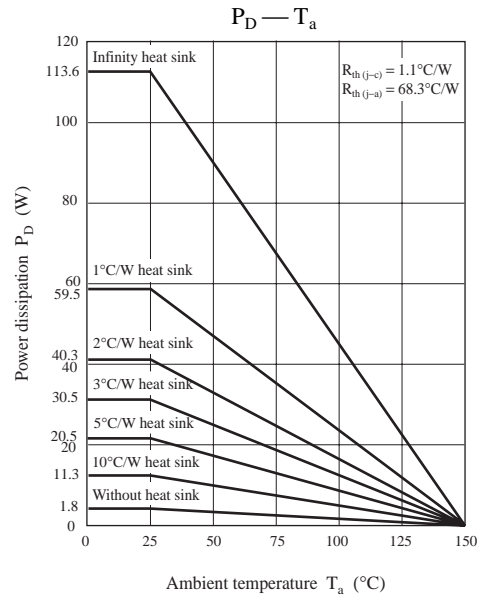

[2] Application note

1. Standby function

- 1) The power can be turned on or off by making pin 5 (standby terminal) high or low.
- 2) The standby terminal has threshold voltage of approx. 2.1 V, however, it has temperature dependency of approx.  $-6 \text{ mV}/^\circ\text{C}$ . The recommended range of use is shown in table 1.

Table 1

Terminal state	Terminal voltage	Power
Open	0 V	Standby state
Low	0 V to 1.0 V	Standby state
High	Higher than 3 V	Operating state

- 3) The internal circuit of standby terminal is as shown in figure 1. When the standby terminal is high, the current approximately expressed by the following equation will flow into the circuit.

$$I_{STB} = \frac{V_{STB} - 2.7 \text{ V}}{10 \text{ k}\Omega} \text{ [mA]}$$

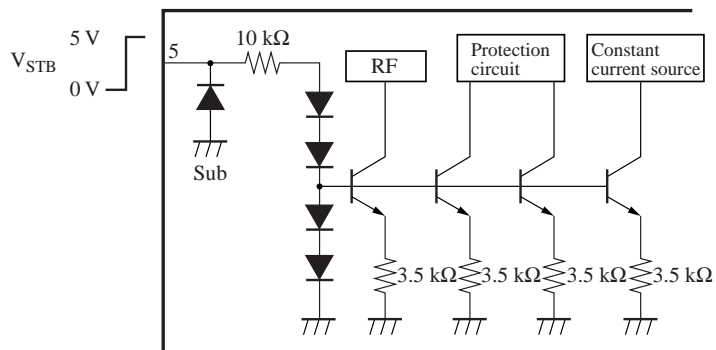

Figure 1

- 4) A power supply with no ripple component should be used for the control voltage of standby terminal .

## ■ Technical Information (continued)

### [2] Application note (continued)

#### 2. Oscillation countermeasures

- 1) In order to increase the oscillation allowance, connect a capacitor and a resistor in series between each output terminal and GND as shown in figure 2.
- 2) The use of polyester film capacitor having a little fluctuation with temperature and frequency is recommended as the 0.1  $\mu\text{F}$  capacitor for oscillation prevention.

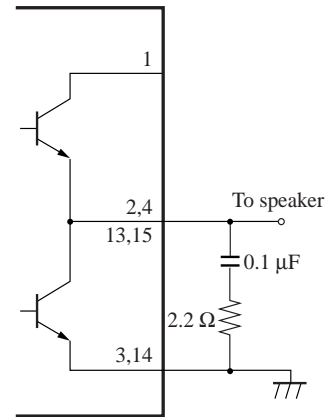

Figure 2

#### 3. Input terminal

- 1) The reference voltage of input terminal is 0 V. When the input signal has a reference voltage other than 0 V potential, connect a coupling capacitor (of about several  $\mu\text{F}$ ) for DC component cut in series with the input terminal. Check the low-pass frequency characteristics to determine the capacitor value.
- 2) 10 k $\Omega$  or less of signal source impedance  $R_g$  can reduce the output end noise voltage.
- 3) The output offset voltage fluctuates when the signal source impedance  $R_g$  is changed. A care must be taken when using the circuit by directly connecting the volume to the input terminal. In such a case, the use of coupling capacitor is recommended.
- 4) If a high frequency signal from tuners enters the input terminal as noise, insert a capacitor of approx. 0.01  $\mu\text{F}$  between the input terminal and input GND.

When a high frequency signal is inputted, malfunction in protective circuits may occur.

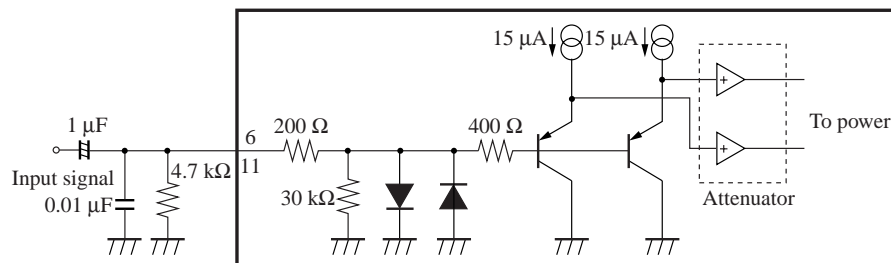

Figure 3

#### 4. Ripple filter

- 1) In order to suppress the fluctuation of supply voltage, connect a capacitor of approx. 33  $\mu\text{F}$  between RF terminal (pin12) and GND.
- 2) Relation between RR (Ripple Rejection Ratio) and a capacitor  
The larger the capacitance of the ripple filter is, the better the ripple rejection becomes.
- 3) Relation between the rise time of circuit and a capacitor  
The larger the capacitance of the ripple filter is, the longer the time from the power on (standby high) to the sound release becomes.
- 4) The DC voltage of output terminal is approximately the middle point of the ripple filter terminal voltage.
- 5) The internal circuit of ripple filter terminal is as shown in figure 4 and the charge current is approx. 3 mA to 10 mA.
- 6) The muting circuit turns on when the ripple filter terminal is  $V_{CC} - 4 V_{BE}$  or less.  
For that reason, abnormal sound due to waveform distortion at rising and falling of the circuit is not released.



## ■ Technical Information (continued)

### [2] Application note (continued)

#### 4. Ripple filter (continued)

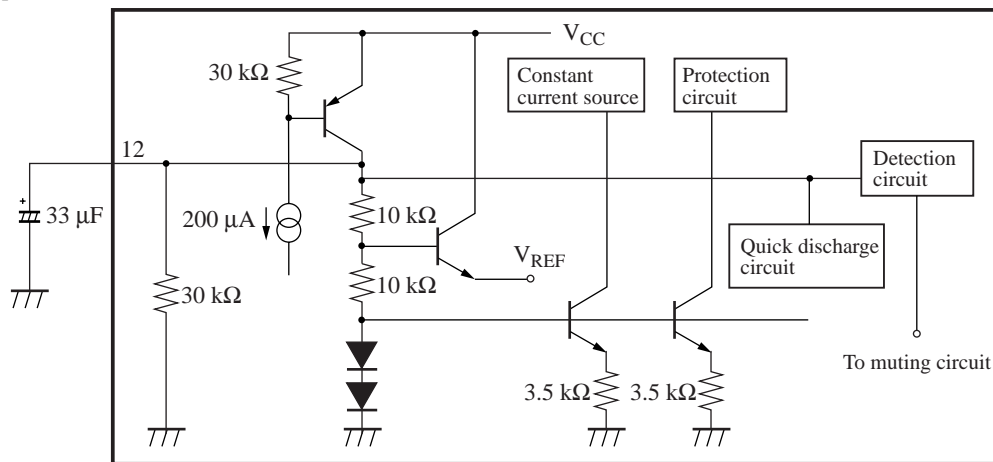

Figure 4

#### 5. GND terminal

- 1) Be sure to short-circuit each GND terminal of pin 3, 8, 9 and 14 at the outside of the IC in use.
- 2) For each GND terminal, the one-point earth, referenced to the GND connection point of electrolytic capacitor between the supply terminal and GND, is most effective for reducing the distortion. Even in the worst case, ground pin 8, 9 of input GND separately from all the other GND terminals.

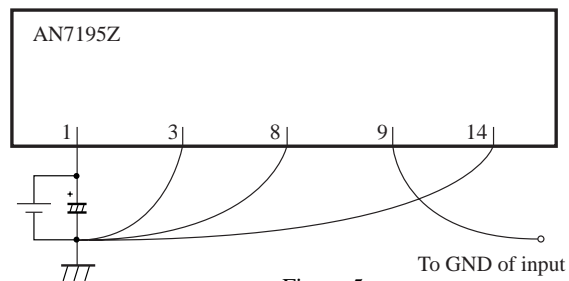

Figure 5

- 3) Each GND terminal is not electrically short-circuited inside. Only pin 8 is connected with substrate.
- 4) Pin 9 is input signal GND. Connect only pin 9 with Pre-GND.

#### 6. Cooling fin

- 1) The cooling fin is not connected with GND terminal by using Au wire. Only pin 8 is electrically connected through substrate.
- 2) Always attach an outside heat sink to the cooling fin. The cooling fin must be fastened onto a chassis for use. Otherwise, IC lead failure may occur.
- 3) Do not give the cooling fin any potential other than the GND potential. Otherwise, it may cause breakdown.
- 4) Connection of the cooling fin with GND can reduce the incoming noise hum. (It is unnecessary to connect with GND in use, but connect with the power GND when the cooling fin is connected with GND)

#### 7. Shock noise

##### 1) STB on/off

No shock noise is released. However, the changeover switch of the standby terminal may make a slight shock noise. In such a case, insert a capacitor of approx. 0.01  $\mu$ F between the standby terminal and GND.

##### 2) Mute on/off

No shock noise is released. Refer to the section on the mute function.

## ■ Technical Information (continued)

### [2] Application note (continued)

#### 8. Mute Function

- 1) The mute-on/off is possible by making pin 7 (the muting terminal) high or low.
- 2) The muting circuit is as shown in figure 6. The amplifier gain including attenuator block is given in the following equation :

$$G_V = \frac{I_1}{I_2} \times 50$$

↙ Original gain

From the above equation, the amplifier gain can be made as 0 time by setting  $I_1$  at 0 mA at muting.

- 3) The threshold voltage of  $V_{MUTE}$  is as follows :

Mute-off : approx. 1 V or less

Mute-on : approx. 3 V or more

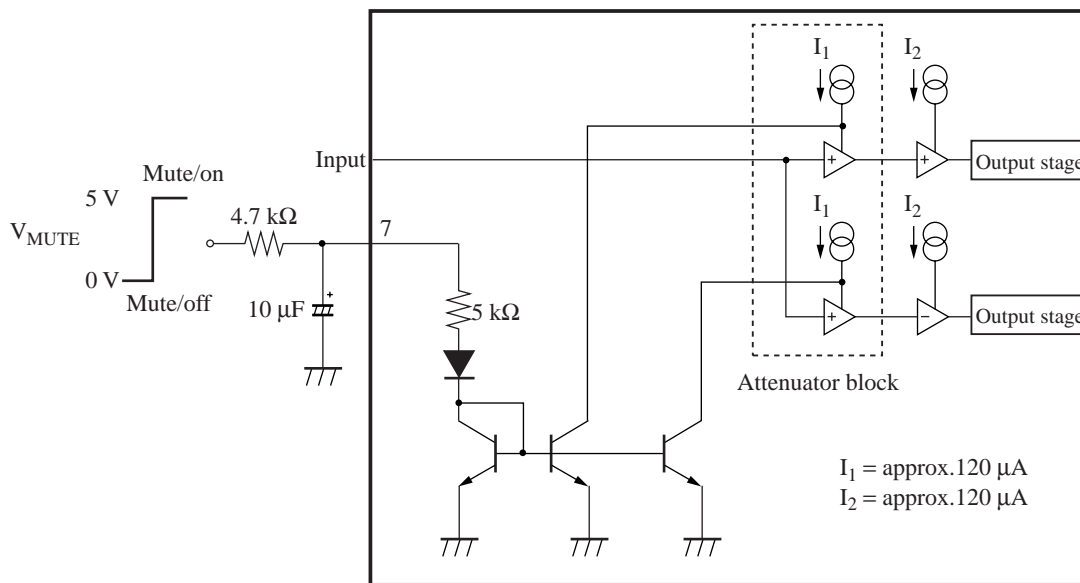

Figure 6

- 4) Attack time and recovery time can be changed by the external CR of pin 7. For recommended circuits (In figure 6 4.7 kΩ, 10 μF), the above mentioned times are as follows :

Attack time : Approx. 30 ms

Recovery time : Approx. 40 ms

However, the control voltage of  $V_{MUTE}$  is assumed to be 5 V. When it is not directly controlled by microcomputer (5 V), (that is, 13.2 V separate power supply), it is necessary to change CR values because the above times change.

- 5) When the attack time and recovery time are set at 20 ms or less, pay attention to the IC with larger output offset because it may release the shock noise.

#### 9. Voltage gain

The voltage gain is fixed at 34 dB and can not be changed by the addition of an external resistor.

■ Technical Information (continued)

[2] Application note (continued)

10. Beep sound input function

- 1) The application circuit using the beep sound input is shown in figure 7. Connect the beep signals from the microcomputer to pin 10 via the capacitor C1 for DC cut and the resistor R1 for voltage gain adjustment.
- 2) The voltage gain of beep sound terminal is approx. -4.5 dB. With settings shown in the following drawing, it is approx. -19 dB (f = 1 kHz).
- 3) The beep signal is outputted to output terminals, pin 2 and pin 15 only.

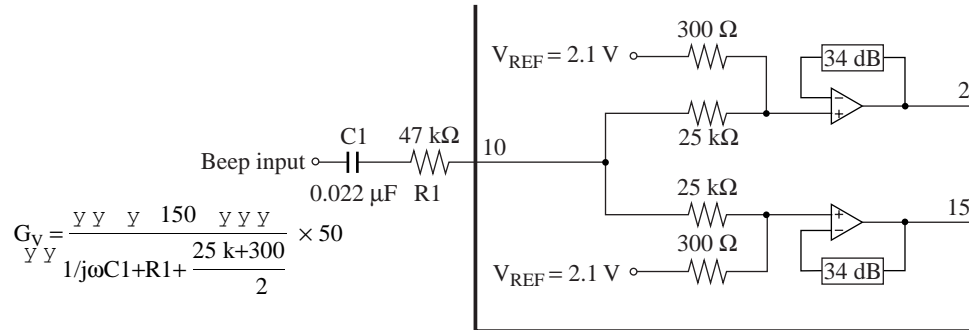

Figure 7

11. Two IC use

Figure 8 shows the application circuit example when two ICs are used :

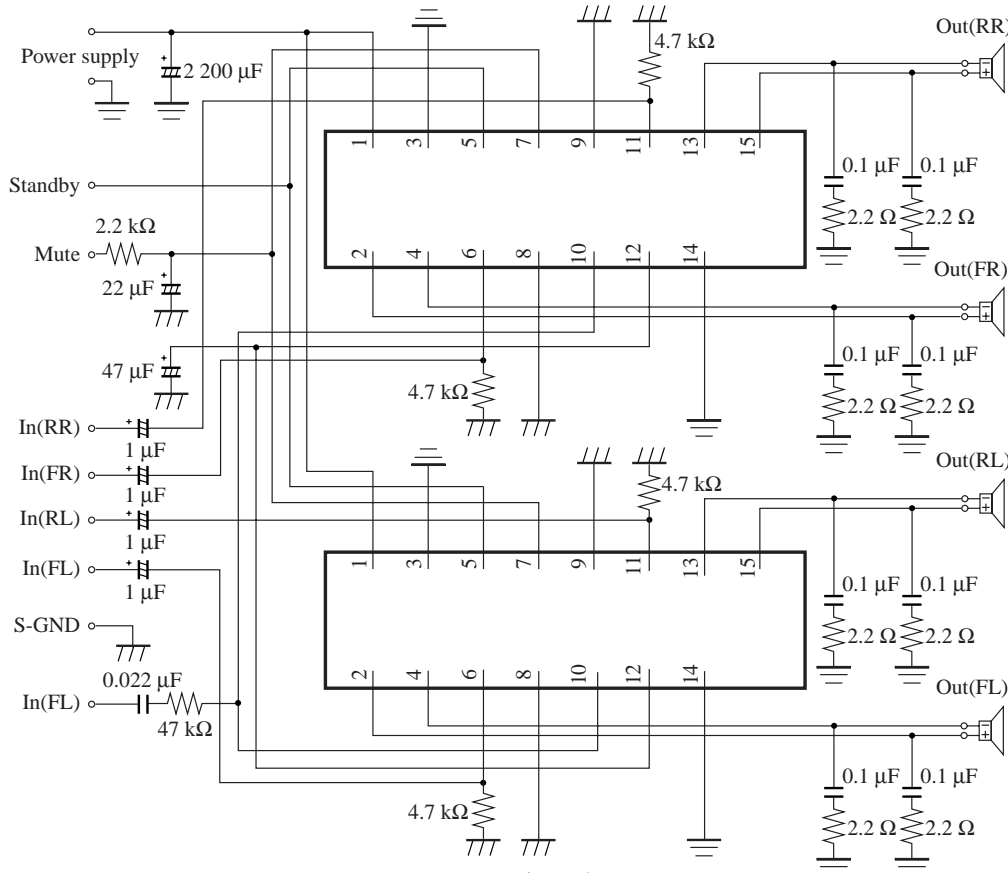

Figure 8

## ■ Technical Information (continued)

### [2] Application note (continued)

#### 11. Two IC use (continued)

##### 1) Supply terminal

Short-circuiting each other, insert an electrolytic capacitor of approx. 2 200  $\mu\text{F}$  into the supply terminals. However, if sufficient characteristics of the ripple rejection can not be obtained, use an even larger capacitor or insert a 2 200  $\mu\text{F}$  capacitor into each IC.

The best sound quality can be obtained by inserting a 2 200  $\mu\text{F}$  capacitor near the terminal of each IC.

##### 2) Standby terminal (pin 5)

Even if the standby terminals are connected with each other, that does not result in an abnormal operation. Connect with the microcomputer after connecting the standby pins with each other. At that time, the current flowing into the standby terminal is twice as large as the current which is described in 1. Standby function.

##### 3) Muting terminal (pin 7)

An abnormal operation does not occur even if the muting terminals are short-circuited with each other.

The muting time constant changes when two ICs connection is made. If the CR constants are set at twice and 1/2 time respectively, the time constant value becomes as same as the value when one IC is used.

##### 4) Beep sound input terminal (pin 10)

Even if the the beep sound input terminals are short-circuited each other, that does not result in an abnormal operation.

However, if there is a temperature difference between ICs, there may be a fluctuation of the output offset. In order to avoid such a phenomenon, connect the ICs with each other through a resistor (47 k $\Omega$ ).

##### 5) Ripple filter terminal (pin 12)

Even if the ripple filter terminals are short-circuited each other, that does not result in an abnormal operation.

However, if the standby of each IC is individually controlled, the short-circuiting is not allowed. Use the circuit after connecting a capacitor (33  $\mu\text{F}$ ) to each IC.

##### 6) If one IC is used as a combination of L or R of the front and the rear, the cross-talk between the L and R increases. The circuit shown by figure 8 becomes thermally advantageous when there is a difference in the output between the front and rear.

##### 7) Arrangement of IC

The larger the distance between the two ICs is, the more advantageous the heat radiation design becomes.

## ■ Application Circuit Example

