

AN7555NZ

BTL output power IC for car audio

■ Overview

The AN7555NZ is an audio power IC developed as the sound output of car audio (35 W × 4-channel). It has realized the voltage gain of 40 dB based on the AN7560Z (voltage gain: 34 dB). A capacitor and resistor to stop oscillation are built in between the output pin and GND so that a space saving of set is possible. Also, it incorporates a perfect muting circuit without shock noise, so that a shock noise design under the set transient condition can be made easily when used together with its standby function. In addition, it incorporates various protection circuits to protect the IC from destruction by GND-open short circuit to ground, and power supply surge which are the important subject of power IC protection. This IC will largely contribute to a high reliability design of the equipment.

■ Features

- A pattern layout in which input and output pattern do not intersect each other on single-sided printed circuit board is possible.
- Incorporating various protection circuits (temperature protection, short circuit to V_{CC} , V_{CC} -open short circuit to V_{CC} , short circuit to GND, GND-open short circuit to GND, overvoltage, power supply surge, and ASO, etc.)
- Built-in standby function (shock-noise free at STB-on/off)
- Built-in muting function (shock-noise free at Mute-on/off)
- External components reduction
- Provided with beep sound input pin
- Equipped with auxiliary sound input pin
- Voltage gain: 40 dB
(AN7560Z/AN7561Z: Voltage gain: 34 dB)

■ Applications

- Car stereo, miniature audio component, karaoke and other audio equipment

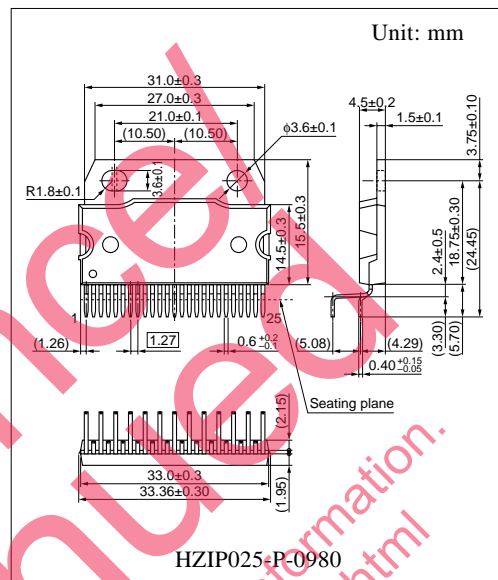

■ Block Diagram

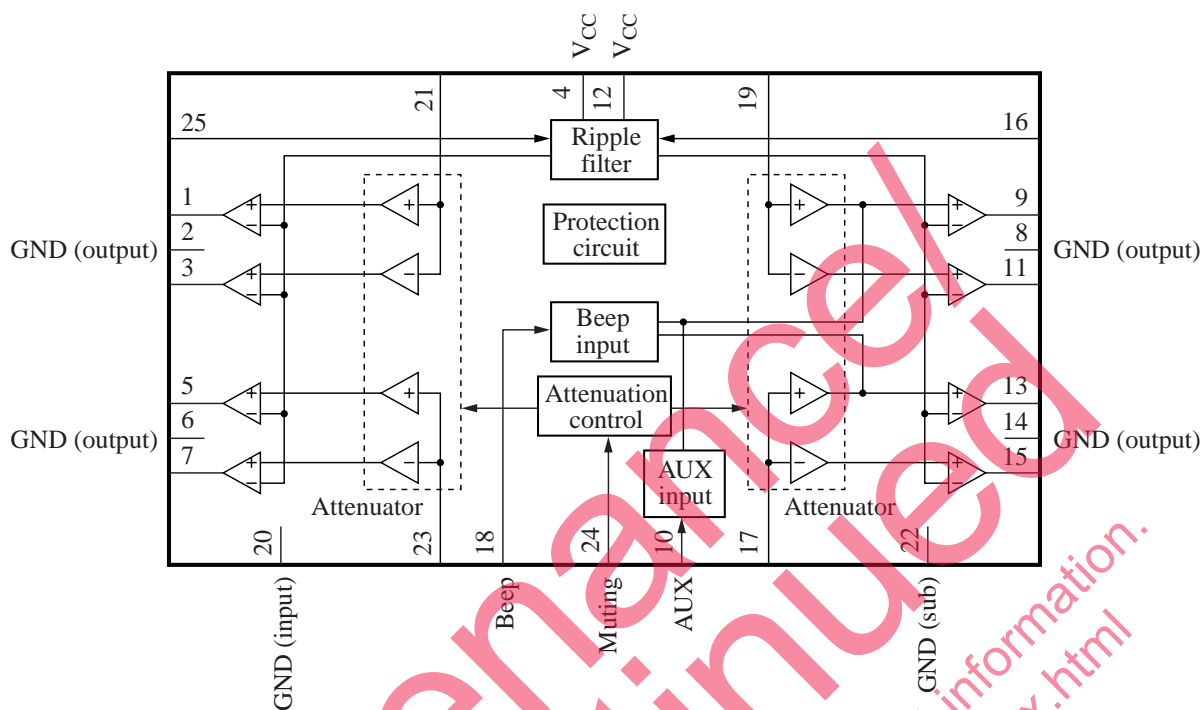

■ Pin Descriptions

Pin No.	Description	Pin No.	Description
1	Ch.4 + output	14	GND (ch.1 output)
2	GND (ch.4 output)	15	Ch.1 - output
3	Ch.4 - output	16	Standby
4	Supply voltage V_{CC}	17	Ch.1 input
5	Ch.3 + output	18	Beep input
6	GND (ch.3 output)	19	Ch.2 input
7	Ch.3 - output	20	GND (input)
8	GND (ch.3 output)	21	Ch.4 input
9	Ch.2 + output	22	GND (printed circuit board)
10	AUX input	23	Ch.3 input
11	Ch.2 - output	24	Muting
12	Supply voltage V_{CC}	25	Ripple filter
13	Ch.1 + output		

Note) It is not necessary to connect capacitor and resistor for stopping the oscillation at the output terminals.
Use them after check if necessary for noise countermeasure.

■ Absolute Maximum Ratings

Parameter	Symbol	Rating	Unit
Supply voltage *2	V_{CC}	25	V
Peak supply voltage *3	V_{surge}	65	V
Supply current	I_{CC}	12	A
Power dissipation *4	P_D	59	W
Operating ambient temperature *1	T_{opr}	-30 to +85	°C
Storage temperature *1	T_{stg}	-55 to +150	°C

Note) *1 : $T_a = 25^\circ\text{C}$ except operating ambient temperature and storage temperature.

*2 : Without signal

*3 : Time = 0.2 s

*4 : Power dissipation at $T_a = 85^\circ\text{C}$

■ Recommended Operating Range

Parameter	Symbol	Range	Unit
Supply voltage	V_{CC}	8.0 to 18.0	V

■ Electrical Characteristics at $V_{CC} = 13.2\text{ V}$, $f = 1\text{ kHz}$, $T_a = 25^\circ\text{C}$

Parameter	Symbol	Conditions	Min	Typ	Max	Unit
Quiescent current	I_{CQ}	$R_g = 10\text{ k}\Omega$, $R_L = 4\ \Omega$	—	300	450	mA
Standby current	I_{STB}	$R_g = 10\text{ k}\Omega$, $R_L = 4\ \Omega$	—	1	10	μA
Output noise voltage *1	V_{NO}	$R_g = 10\text{ k}\Omega$, $R_L = 4\ \Omega$	—	0.25	0.5	mV[rms]
Voltage gain	G_V	$V_{IN} = 20\text{ mV}$, $R_L = 4\ \Omega$	38	40	42	dB
Total harmonic distortion 1	THD1	$V_{IN} = 20\text{ mV}$, $R_L = 4\ \Omega$	—	0.05	0.2	%
Maximum output power	P_O	THD = 10%, $R_L = 4\ \Omega$	16	19.5	—	W
Ripple rejection *1	RR	$R_L = 4\ \Omega$, $R_g = 10\text{ k}\Omega$, $V_R = 1\text{ V[rms]}$, $f_R = 1\text{ kHz}$	55	65	—	dB
Channel balance	CB	$V_{IN} = 20\text{ mV}$, $R_L = 4\ \Omega$	—	0	1	dB
Cross-talk	CT	$V_{IN} = 20\text{ mV}$, $R_L = 4\ \Omega$, $R_g = 10\text{ k}\Omega$	60	70	—	dB
Output offset voltage	V_{OFF}	$R_g = 10\text{ k}\Omega$, $R_L = 4\ \Omega$	-300	0	300	mV
Muting effect *1	MT	$V_{IN} = 20\text{ mV}$, $R_L = 4\ \Omega$	70	80	—	dB
Input impedance	Z_I	$V_{IN} = \pm 0.3\ V_{DC}$	24	30	36	k Ω
Shock noise *2	V_S	$R_L = 4\ \Omega$, $R_g = 10\text{ k}\Omega$, $V_{MUTE} = 5\text{ V}$, $V_{STB} = \text{on/off}$, 50 Hz HPF	-100	0	100	mV[p-0]

Note) *1 : Measurement using a bandwidth 15 Hz to 30 kHz (12 dB/OCT) filter.

*2 : Change over the standby terminal at the time shown in the right.

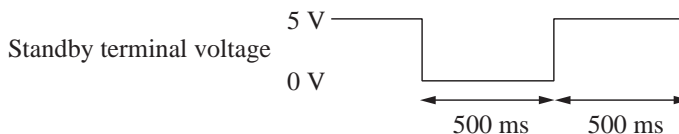

■ Electrical Characteristics at $V_{CC} = 13.2\text{ V}$, $f = 1\text{ kHz}$, $T_a = 25^\circ\text{C}$ (continued)

Parameter	Symbol	Conditions	Min	Typ	Max	Unit
Total harmonic distortion 2	THD2	$V_{IN} = 10\text{ mV}$, $f_{IN} = 20\text{ kHz}$, $R_g = 10\ \Omega$, $R_L = \infty$	—	0.1	0.5	%
Mute-on threshold voltage	MT _{ON}	$V_{IN} = 20\text{ mV}$, $R_L = 4\ \Omega$	4	—	—	V
Mute-off threshold voltage	MT _{OFF}	$V_{IN} = 20\text{ mV}$, $R_L = 4\ \Omega$	—	—	0.8	V
Cutoff frequency	f_C	$V_{IN} = 20\text{ mV}$, $R_L = 4\ \Omega$, $G_V = -1\text{ dB}$ (0 dB: 1 kHz)	20	40	—	kHz

• Design reference data

Note) The characteristic values below are theoretical values for designing and not guaranteed.

Parameter	Symbol	Conditions	Min	Typ	Max	Unit
Maximum output power	P _{Omax}	Max. power, $R_L = 4\ \Omega$	—	28	—	W
	P _{O2}	$V_{CC} = 14.4\text{ V}$, THD = 10%, $R_L = 4\ \Omega$	—	21	—	
	P _{Omax2}	$V_{CC} = 14.4\text{ V}$, max. power, $R_L = 4\ \Omega$	—	34	—	
Power band width	f_{PL}	$V_{CC} = 14.4\text{ V}$, THD = 1%, $R_L = 4\ \Omega$, PoL = -3 dB (1 kHz: 0 dB)	—	10	—	Hz
	f_{PH}	$V_{CC} = 14.4\text{ V}$, THD = 1%, $R_L = 4\ \Omega$, PoH = -3 dB (1 kHz: 0 dB)	—	18	—	kHz
STB threshold voltage	V _{STB1}	$R_g = 10\text{ k}\Omega$, $R_L = 4\ \Omega$, STB → ACT	—	2.2	—	V
	V _{STB2}	$R_g = 10\text{ k}\Omega$, $R_L = 4\ \Omega$, ACT → STB	—	1.5	—	

■ Usage Notes

1. Always attach an outside heat sink to use the AN7555NZ. In addition, the outside heat sink must be fastened onto a chassis for use.
2. Connect the radiation fin to the GND potential.
3. Prevent short circuit to V_{CC} and short circuit to GND, and load short-circuit although the protection circuits for short circuit to V_{CC} and ASO are built-in.
4. The thermal protection circuit gets actuated when $T_c =$ approx. 150°C , but it is automatically reset when the chip temperature drops below the above set level.
5. The overvoltage protection circuit starts the protection operation at $V_{CC} =$ approx. 20 V .
6. Take into consideration the heat radiation design particularly when V_{CC} is set high.
7. When the beep sound function is not used, connect to GND the beep sound input pin.
8. Don't down below -0.3 V for the beep sound input pin.
9. When the AUX function is not used, open the AUX input pin.
10. Connect to signal GND of pre-stage amplifier only for the signal source ground.

• There are the possibility of breakdown for the following conditions.

1. Reverse connection of the power supply pin and the GND pin.
2. Connection of the power supply between output pins at open condition of the power supply pin and the GND pin.
3. Short circuit to GND of output pin when the GND pin is open.
4. Short circuit to GND of above the three output pins at the same time with a shorting resistor which does not operate the protection circuit.
5. Short circuit to GND of above the plus and minus output pins at the same time with a shorting resistor which does not operate the protection circuit.
6. Short circuit to ground with shorting the RF pin and the output pin.

■ Technical Information

- $P_D - T_a$ curves of HZIP025-P-0980

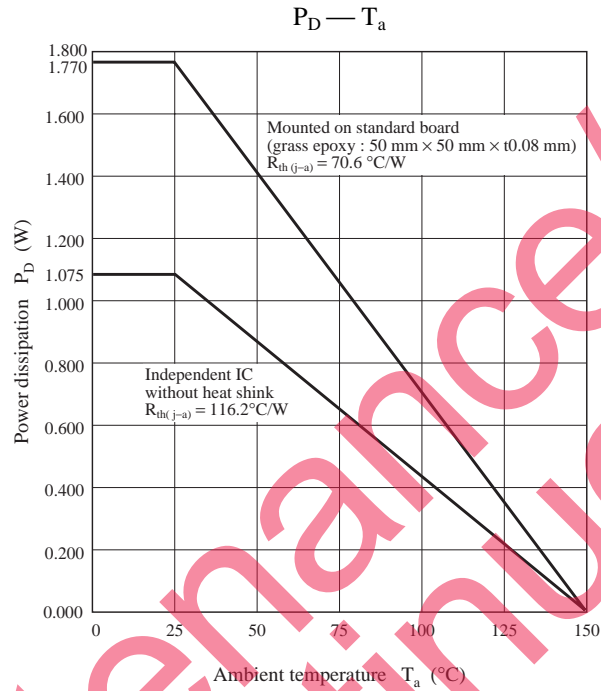

■ Application Circuit Example

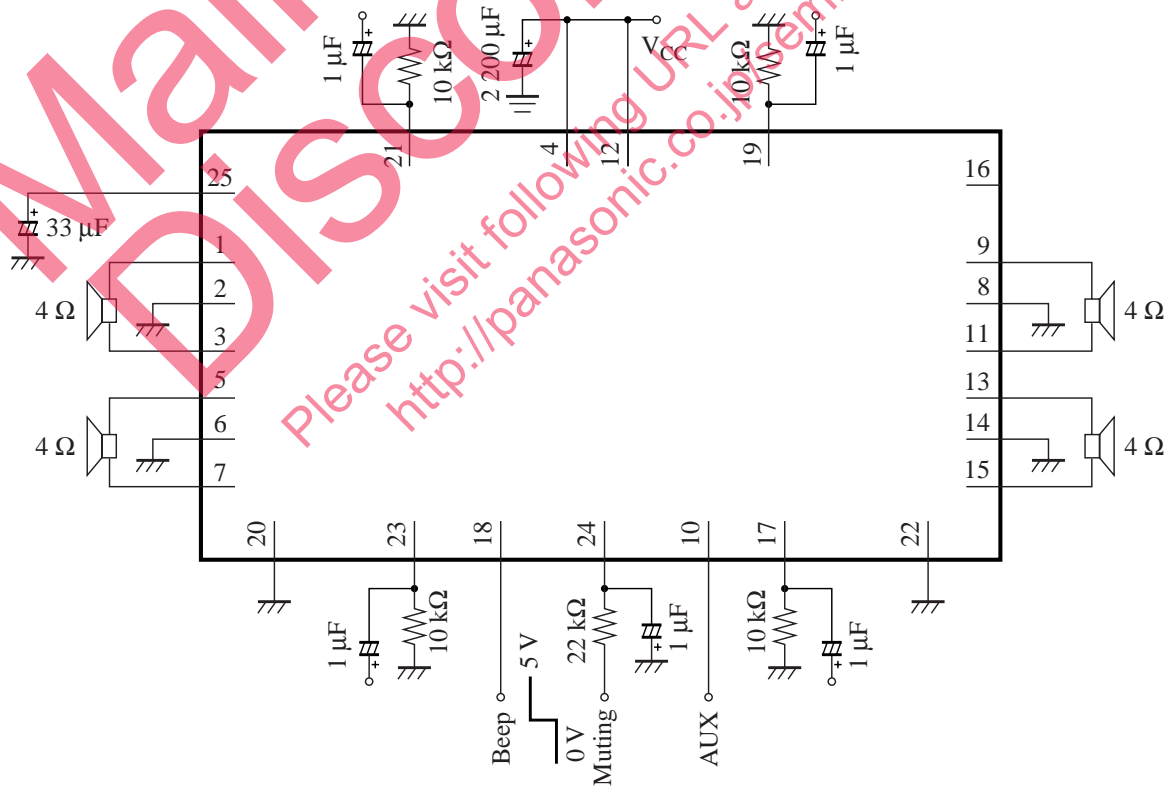

Request for your special attention and precautions in using the technical information and semiconductors described in this book

- (1) If any of the products or technical information described in this book is to be exported or provided to non-residents, the laws and regulations of the exporting country, especially, those with regard to security export control, must be observed.
- (2) The technical information described in this book is intended only to show the main characteristics and application circuit examples of the products, and no license is granted under any intellectual property right or other right owned by our company or any other company. Therefore, no responsibility is assumed by our company as to the infringement upon any such right owned by any other company which may arise as a result of the use of technical information described in this book.
- (3) The products described in this book are intended to be used for standard applications or general electronic equipment (such as office equipment, communications equipment, measuring instruments and household appliances).
Consult our sales staff in advance for information on the following applications:
 - Special applications (such as for airplanes, aerospace, automobiles, traffic control equipment, combustion equipment, life support systems and safety devices) in which exceptional quality and reliability are required, or if the failure or malfunction of the products may directly jeopardize life or harm the human body.
 - Any applications other than the standard applications intended.
- (4) The products and product specifications described in this book are subject to change without notice for modification and/or improvement. At the final stage of your design, purchasing, or use of the products, therefore, ask for the most up-to-date Product Standards in advance to make sure that the latest specifications satisfy your requirements.
- (5) When designing your equipment, comply with the range of absolute maximum rating and the guaranteed operating conditions (operating power supply voltage and operating environment etc.). Especially, please be careful not to exceed the range of absolute maximum rating on the transient state, such as power-on, power-off and mode-switching. Otherwise, we will not be liable for any defect which may arise later in your equipment.
 - Even when the products are used within the guaranteed values, take into the consideration of incidence of break down and failure mode, possible to occur to semiconductor products. Measures on the systems such as redundant design, arresting the spread of fire or preventing glitch are recommended in order to prevent physical injury, fire, social damages, for example, by using the products.
- (6) Comply with the instructions for use in order to prevent breakdown and characteristics change due to external factors (ESD, EOS, thermal stress and mechanical stress) at the time of handling, mounting or at customer's process. When using products for which damp-proof packing is required, satisfy the conditions, such as shelf life and the elapsed time since first opening the packages.
- (7) This book may be not reprinted or reproduced whether wholly or partially, without the prior written permission of Matsushita Electric Industrial Co., Ltd.