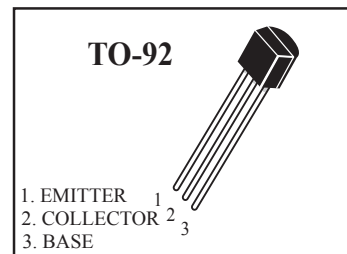

PNP/NPN Epitaxial Planar Transistors

ABSOLUTE MAXIMUM RATINGS (Ta=25°C)

Rating	Symbol	PNP/WTS772	NPN/WTS882	Unit
Collector-Emitter Voltage	V _{CEO}	-30	30	V _{dc}
Collector-Base Voltage	V _{CBO}	-40	40	V _{dc}
Emitter-Base Voltage	V _{EBO}	-5.0	5.0	V _{dc}
Collector Current (DC)	I _{C(DC)}	-3.0	3.0	A _{dc}
Collector Current (Pulse) ⁽¹⁾	I _{C(Pulse)}	-7.0	7.0	A _{dc}
Base Current	I _{B(Pulse)}	-0.6	0.6	A _{dc}
Total Device Dissipation T _A =25°C	P _D	0.625		W
Junction Temperature	T _j	150		°C
Storage, Temperature	T _{stg}	-55 to +150		°C

Device Marking

WTS772=B772 , WTS882=D882

ELECTRICAL CHARACTERISTICS

Characteristics	Symbol	Min	Max	Unit
Collector-Emitter Breakdown Voltage (I _C = -10/10 mA _{dc} , I _B =0)	V _{(BR)CEO}	-30/30	-	V _{dc}
Collector-Base Breakdown Voltage (I _C = -100/100 μA _{dc} , I _E =0)	V _{(BR)CBO}	-40/40	-	V _{dc}
Emitter-Base Breakdown Voltage (I _E = -100/100 μA _{dc} , I _C =0)	V _{(BR)EBO}	-5.0/5.0	-	V _{dc}
Collector Cutoff Current (V _{CE} = -30/30 V _{dc} , I _B =0)	I _{CEO}	-	-1.0/1.0	uA _{dc}
Collector Cutoff Current (V _{CB} = -40/40 V _{dc} , I _E =0)	I _{CBO}	-	-1.0/1.0	uA _{dc}
Emitter Cutoff Current (V _{EB} = -6.0/6.0V _{dc} , I _C =0)	I _{EBO}	-	-1.0/1.0	uA _{dc}

NOTE: 1. PW ≤ 350us, duty cycle ≤ 2%

WTS772
WTS882



ELECTRICAL CHARACTERISTICS ($T_A=25^\circ\text{C}$ unless otherwise noted) (Continued)

Characteristics	Symbol	Min	TYP	Max	Unit
-----------------	--------	-----	-----	-----	------

ON CHARACTERISTICS

DC Current Gain ($I_C = -1.0/1.0 \text{ Adc}, V_{CE} = -2.0/2.0 \text{ Vdc}$)	$h_{FE} (1)$	60	-	400	-
DC Current Gain ($I_C = -100/100 \text{ mAdc}, V_{CE} = -2.0/2.0 \text{ Vdc}$)	$h_{FE} (2)$	32	-	-	-
Collector-Emitter Saturation Voltage ($I_C = -2.0/2.0 \text{ Adc}, I_B = -0.2/0.2 \text{ mAdc}$)	$V_{CE(sat)}$	-	-	-0.5/0.5	Vdc
Base-Emitter Saturation Voltage ($I_C = -2.0/2.0 \text{ Adc}, I_B = -0.2/0.2 \text{ mAdc}$)	$V_{BE(sat)}$	-	-	-2.0/2.0	Vdc
Current-Gain-Bandwidth Product ($I_C = -0.1/0.1 \text{ mAdc}, V_{CE} = -5.0/5.0 \text{ Vdc}, f = 10 \text{ MHz}$)	f_T	-	80/90	-	MHz

Classification of $h_{FE}(1)$

Rank	R	O	Y	GR
Range	60-120	100-200	160-320	200-400

F1. Total Power Dissipation VS. Ambient Temperature

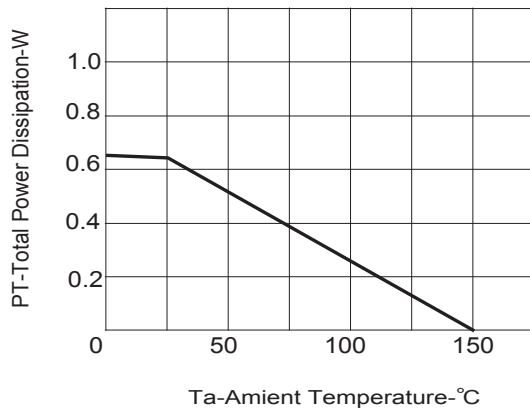

F.2 Derating Curve for All Types

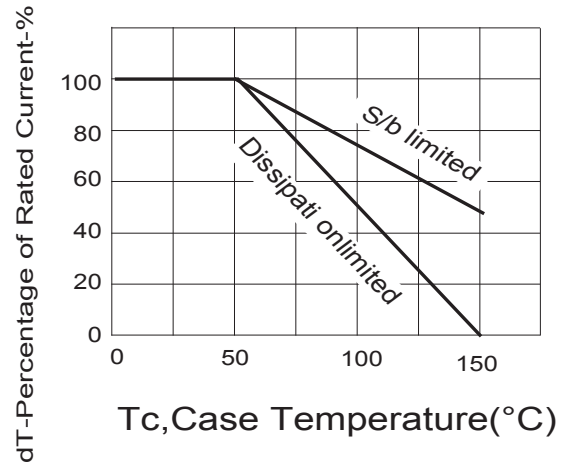

F3. Thermal Resistance VS. Pulse Width

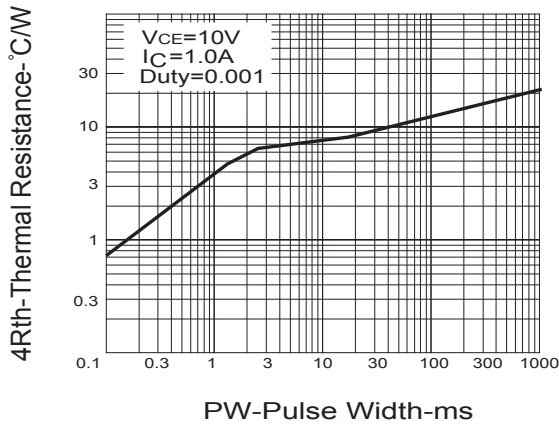

F4. Safe Operating Areas

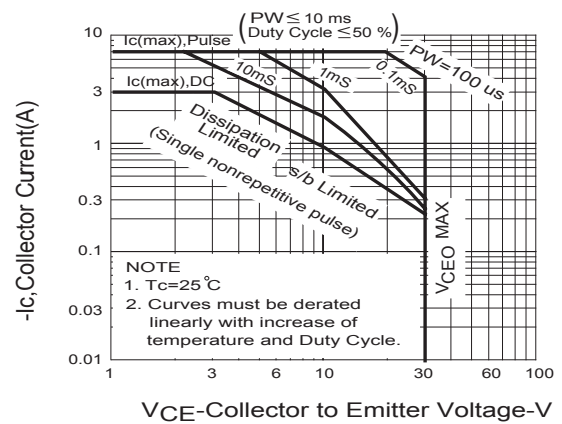

WTS772

F5. Collector Current VS. Collector To Emitter Voltage

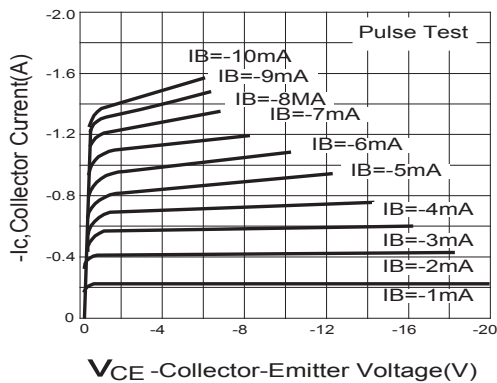

WTS882

F6. Collector Current VS. Collector To Emitter Voltage

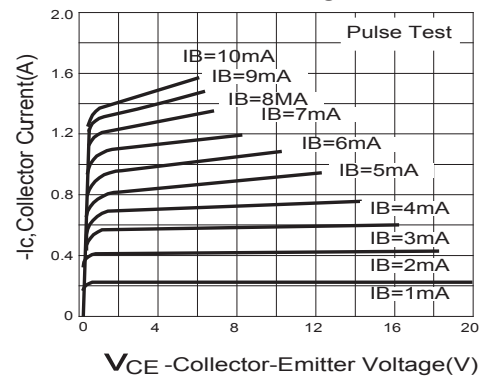

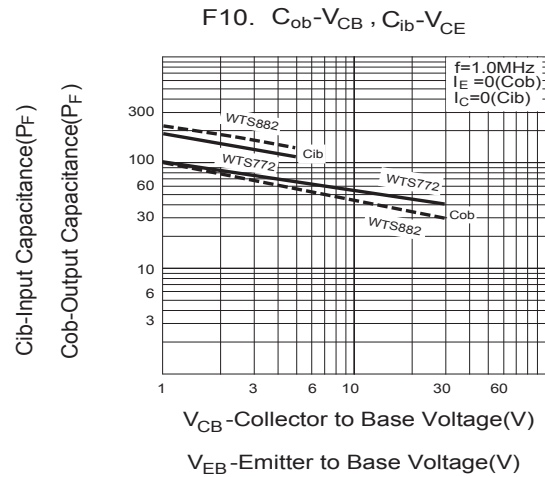
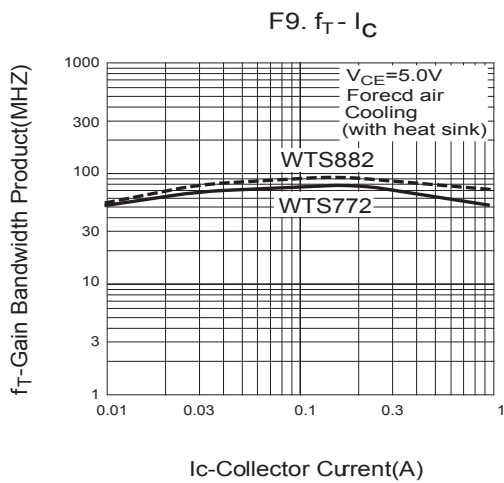
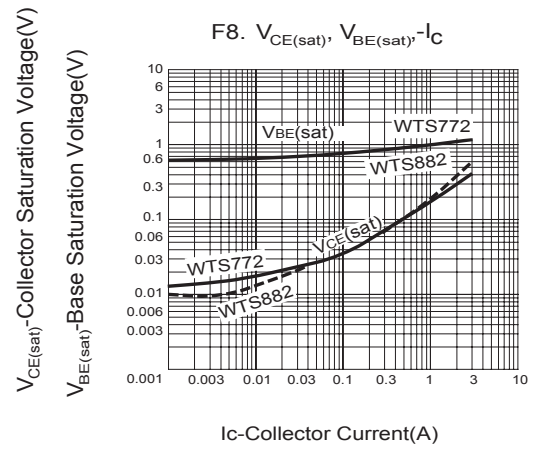
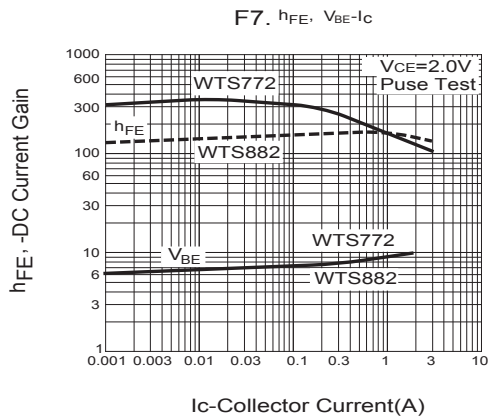

TO-92 Outline Dimensions

unit:mm

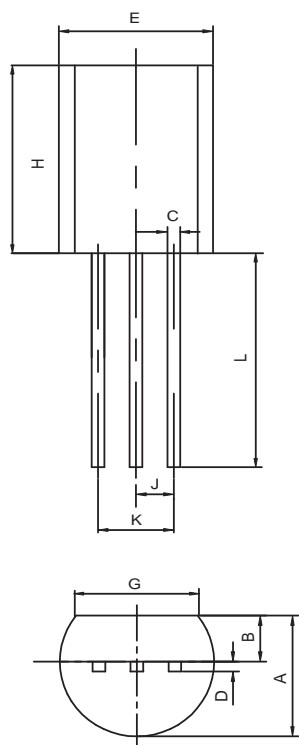

TO-92		
Dim	Min	Max
A	3.30	3.70
B	1.10	1.40
C	0.38	0.55
D	0.36	0.51
E	4.40	4.70
G	3.43	-
H	4.30	4.70
J	1.270TYP	
K	2.44	2.64
L	14.10	14.50