

# PBL 388 14

## Voice - switched 2-channel Circuit with loudspeaker amplifier

### Description.

The PBL 388 14 contains all the necessary circuitry, amplifiers, detectors, comparator and control functions to implement a high performance voice switched handsfree two-way communication system. The gain dynamics (attenuation between channels) is selectable (25dB or 50dB) via a separate pin. A background noise detector in the transmitting channel reduces the influence of continuous external noise signals to the switching.

The PBL 388 14 is designed for mains powered handsfree telephones, vehicular mobile telephone handsfree systems and handsfree intercom systems. Automatic volume attenuation in the power amplifier extends the operating range at low supply currents. The circuit has two special features, the power amplifiers volume control can be implemented either as an ac. potentiometer control or as a digital control by a  $\mu$ -processor (dc. control) and that the feedback loop of the power amplifier is accessible thus making it possible to add a simple external power stage driving low impedance loudspeakers up to several watts.

Filtering is possible of both, the audio and the speech switching control signals, in both transmitter and receiver channels.

### Key Features

- Minimum of external components needed for function.
- Selectable gain dynamics. (25 or 50 dB)
- Low power consumption:  $\approx 1\text{mA}$  at 3.3V (typical) for speech switching, audio power amplifier quiescent current  $\approx 1\text{mA}$ .
- Drives an 25 - 50 ohm loudspeaker without a transformer.
- Background noise compensation in the transmitting channel with hold function at receive.
- Input amplifiers of both channels have balanced inputs.
- Excellent noise performance.
- Encapsulated in 24 pin plastic "skinny" DIP and 24 pin SO.

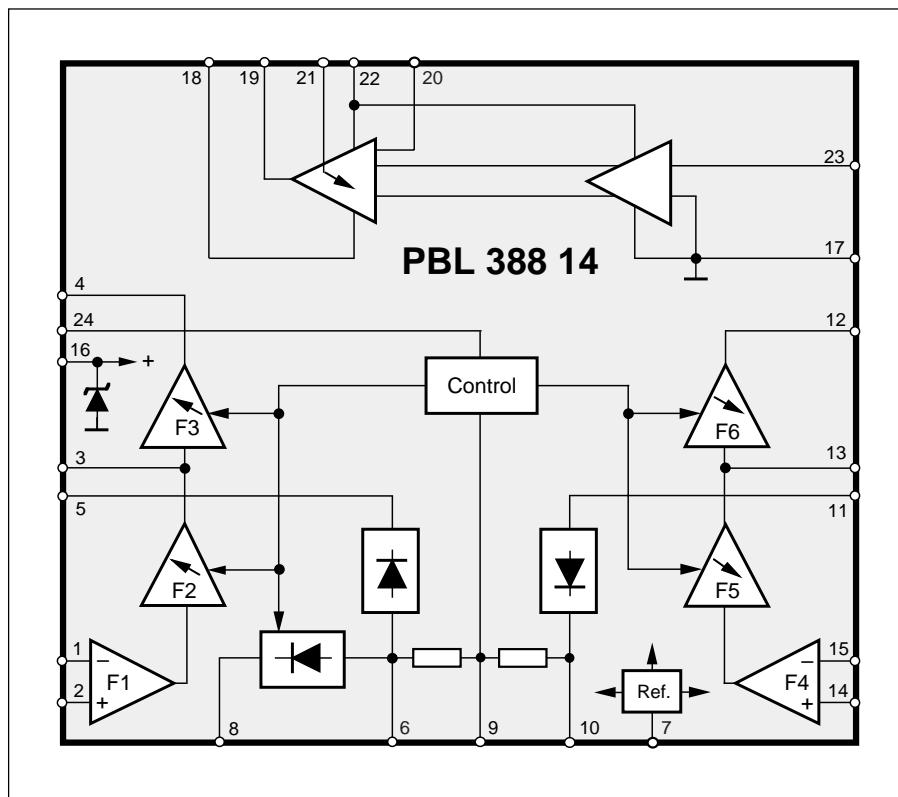
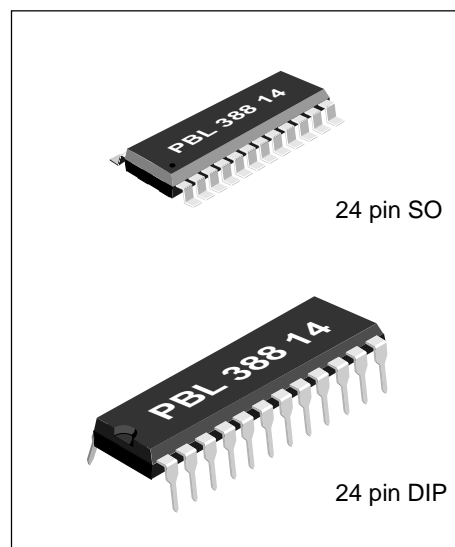

Figure 1. Block diagram.



### Maximum Ratings

Parameter	Symbol	Min	Max	Unit
Speech switch supply current	$I_D$		10	mA
Speaker amplifier supply current	$I_{+L}$		130	mA
Voltage pin 1-14		-0,5	$V_{pin_{15}}+0.5$	V
Operating temperature	$T_{Amb}$	-20	+70	°C
Storage temperature	$T_{Stg}$	-55	+125	°C

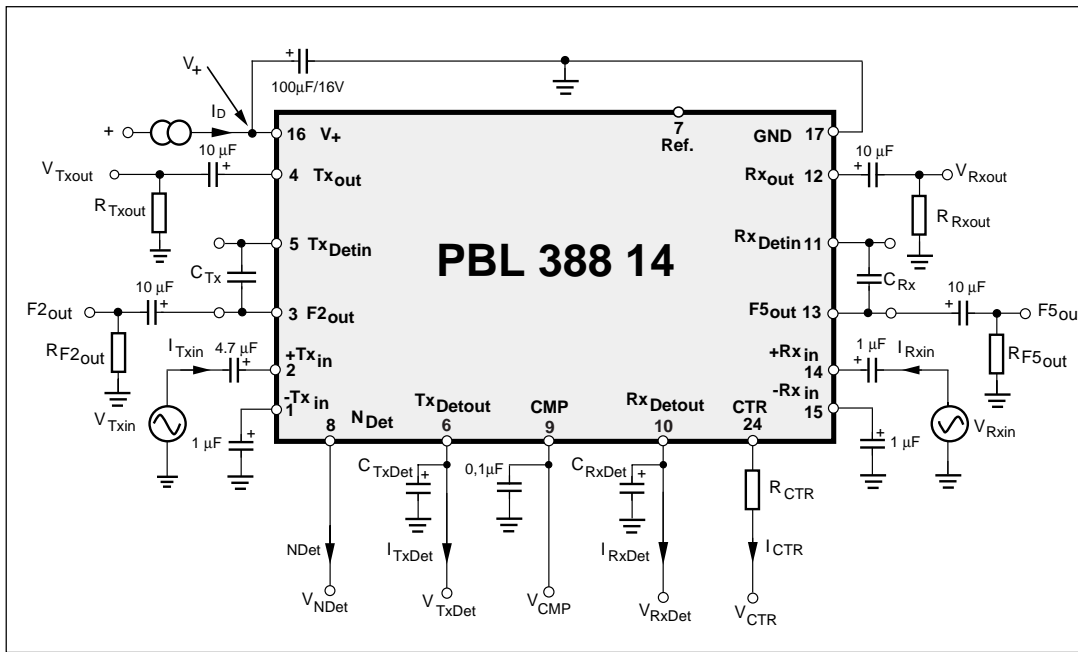

Figure 2. Test circuit. Reference figure No. 2.

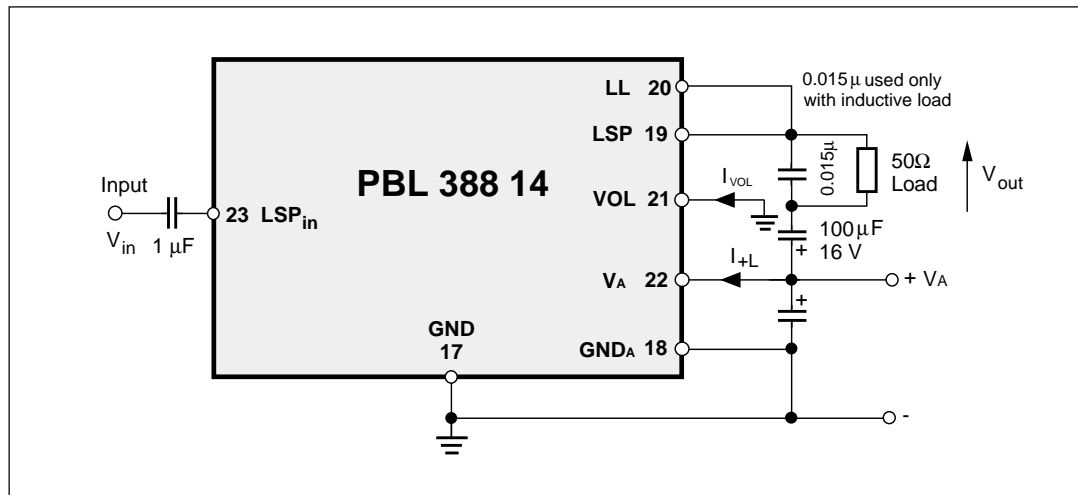

Figure 3. Test circuit. Reference figure No. 3.

**Electrical Characteristics**

f = 1 kHz, T = 25°C, R<sub>CTR</sub>=0, C<sub>TxDet</sub> = 0, R<sub>Txout</sub> = ∞, R<sub>Rxout</sub> = ∞, R<sub>F2out</sub> = ∞, R<sub>F5out</sub> = ∞, C<sub>Tx</sub> = 0, C<sub>Rx</sub> = 0, C<sub>RxDet</sub> = 0 and I<sub>D</sub>=1.0mA unless otherwise noted.

Parameter	Ref. fig.	Condition	Min.	Typ.	Max.	Unit.
<b>Speech control section</b>						
Terminal voltage, V <sub>+</sub>	2	I <sub>D</sub> = 1.0mA		3.3		V
Internal reference voltage, V <sub>Ref</sub>	2			1.96		V
Frequency response for all amplifiers	2	200 - 3400 Hz, Relative 1 kHz	-1		1	dB
Transmit gain, 20 • 10 log(V <sub>Txout</sub> / V <sub>Txin</sub> )	2	V <sub>CMP</sub> = V <sub>Ref</sub> - 0.1 V	40.5	43		dB
		V <sub>CMP</sub> = V <sub>Ref</sub> + 0.1 V		-7	-4.5	dB
		V <sub>CMP</sub> = V <sub>Ref</sub> - 0.1 V R <sub>CTR</sub> =100k, V <sub>CTR</sub> =V+	40.5	43		dB
		V <sub>CMP</sub> = V <sub>Ref</sub> + 0.1 V R <sub>CTR</sub> =100k, V <sub>CTR</sub> =V+		18	20.5	dB
Receive gain, 20 • 10 log(V <sub>Rxout</sub> / V <sub>Rxin</sub> )	2	V <sub>CMP</sub> = V <sub>Ref</sub> + 0.1 V	26.5	29		dB
		V <sub>CMP</sub> = V <sub>Ref</sub> - 0.1 V		-21	-18.5	dB
		V <sub>CMP</sub> = V <sub>Ref</sub> + 0.1 V R <sub>CTR</sub> =100k, V <sub>CTR</sub> =V+	26.5	29		dB
		V <sub>CMP</sub> = V <sub>Ref</sub> - 0.1 V R <sub>CTR</sub> =100k, V <sub>CTR</sub> =V+		4	6.5	dB
Max transmit detector gain, 20 • 10 log(V <sub>Txdet</sub> / V <sub>Txin</sub> )	2	V <sub>Txdet</sub> < 200 mV <sub>p</sub> , C <sub>Rx</sub> = 100nF		67		dB
		V <sub>CMP</sub> = V <sub>Ref</sub> - 0.1 V		36.5	42	dB
		V <sub>CMP</sub> = V <sub>Ref</sub> + 0.1 V				
Max receive detector gain, 20 • 10 log(V <sub>Rxdet</sub> / V <sub>Rxin</sub> )	2	V <sub>Rxdet</sub> < 200 mV <sub>p</sub> , C <sub>Tx</sub> = 100nF		53		dB
		V <sub>CMP</sub> = V <sub>Ref</sub> + 0.1 V		22.5	28	dB
		V <sub>CMP</sub> = V <sub>Ref</sub> - 0.1 V				
Background noise rectifier gain, (note 1)	2	V <sub>CMP</sub> = V <sub>Ref</sub> - 0.1 V, C <sub>Txdet</sub> =1μF		6.0		dB
		V <sub>CMP</sub> = V <sub>Ref</sub> + 0.1 V, C <sub>Txdet</sub> =1μF		Hold		
+ Tx <sub>In</sub> input impedance	2		80	100	120	kΩ
- Tx <sub>In</sub> input impedance	2		2.4	3.0	3.6	kΩ
+ Rx <sub>In</sub> input impedance	2		120	140	160	kΩ
- Rx <sub>In</sub> input impedance	2		16	20	24	kΩ
Tx <sub>Out</sub> ac, load impedance	2		10			kΩ
Rx <sub>Out</sub> ac, load impedance	2		10			kΩ
F2 <sub>Out</sub> ac, load impedance	2		10			kΩ
F5 <sub>Out</sub> ac, load impedance	2		10			kΩ
Transmitter channel output swing, v <sub>TxOut</sub>	2	2% distortion, R <sub>Txout</sub> =R <sub>Rxout</sub> =10k Ω		500		mV <sub>p</sub>
Receiver channel output swing, v <sub>RxOut</sub>	2	2% distortion, R <sub>Txout</sub> =R <sub>Rxout</sub> =10k Ω		500		mV <sub>p</sub>
Transmitter output noise, v <sub>TxOut</sub>	2	V <sub>CMP</sub> = V <sub>Ref</sub> - 0.1 V, v <sub>Txin</sub> = 0 V		-75		dB <sub>psof</sub>
Receiver output noise, v <sub>RxOut</sub>	2	V <sub>CMP</sub> = V <sub>Ref</sub> + 0.1 V, v <sub>Rxin</sub> = 0 V		-80		dB <sub>A</sub>
Tx <sub>Det</sub> sink current, I <sub>TxDetOut</sub>	2	V <sub>TxDetIn</sub> = V <sub>Ref</sub> + 0.1 V		-6.0	-2.5	mA
Rx <sub>Det</sub> source current, I <sub>RxDetOut</sub>	2	V <sub>RxDetIn</sub> = V <sub>Ref</sub> - 0.1 V	2.5	6.0		mA
Tx <sub>Det</sub> source current, I <sub>TxDet</sub>	2	V <sub>CMP</sub> = V <sub>Ref</sub> - 0.1 V			30	μA
Rx <sub>Det</sub> sink current, I <sub>RxDetOut</sub>	2	V <sub>RxDetIn</sub> = V <sub>Ref</sub> + 0.1 V	-30			μA
Tx <sub>Det</sub> swing relative to V <sub>Ref</sub> , V <sub>TxDetOut</sub>	2	V <sub>TxDetIn</sub> = V <sub>Ref</sub> + 0.1 V	(note 2)	-0.7		V
Rx <sub>Det</sub> swing relative to V <sub>Ref</sub> , V <sub>RxDetOut</sub>	2	V <sub>RxDetIn</sub> = V <sub>Ref</sub> - 0.1 V	(note 2)	+0.7		V
N <sub>Det</sub> sink current (fast charge), I <sub>NDet</sub>	2	V <sub>TxDetIn</sub> = V <sub>Ref</sub> - 0.1 V		-3	-1	mA
		V <sub>CMP</sub> = V <sub>Ref</sub> - 0.1 V				
N <sub>Det</sub> source current, I <sub>NDet</sub>	2	V <sub>TxDetIn</sub> = V <sub>Ref</sub> + 0.1 V	3	5	7	μA
		V <sub>CMP</sub> = V <sub>Ref</sub> - 0.1 V				

Parameter	Ref. fig.	Conditions	Min.	Typ.	Max.	Unit.
$N_{Det}$ leakage current (hold), $I_{NDet}$	2	$V_{TxDetIn} = V_{Ref} - 0.1 V$ , $V_{CMP} = V_{Ref} + 0.1 V$ ,		-100		nA
$N_{Det}$ swing relative to $V_{Ref}$ , $V_{NDet}$	2	$V_{TxDetIn} = V_{Ref} + 0.1 V$ , $V_{CMP} = V_{Ref} - 0.1 V$		0.45		V
CMP (comparator) sensitivity, transmit (Tx) mode to receive (Rx) mode or vice versa	2 12	Tx mode = max Tx gain, Rx mode = max Rx gain		40	80	mV
CTR voltage for 25 dB dynamics, $V_{CTR}$	2,14	$R_{CTR}=100k\Omega$		$V_+$		V
CTR voltage for mute, $V_{CTR}$	2,14		1.1		1.6	V
CTR voltage for disable, $V_{CTR}$	2,14				0.9	V
<b>Loudspeaker amplifier</b>						
Operating voltage, $V_A$	3		2.5		12	V
Current consumption (no signal), $I_{+L}$	3	$V_A = 3.0 V$		1	2.3	mA
	3	$V_A = 5.0 V$		2		mA
	3	$V_A = 12.0 V$		4	9	mA
Current consumption (output swing at 5% dist.)	3	$V_A = 3.0 V$		7		mA
	3	$V_A = 5.0 V$		13		mA
	3	$V_A = 12.0 V$		30		mA
Swing at 5% dist., $V_{Out}$	3	$V_A = 3.0 V$	0.6	0.85		$V_p$
	3	$V_A = 5.0 V$	1.5	1.7		$V_p$
	3	$V_A = 12.0 V$	3.6	4.0		$V_p$
Gain	3	$V_A = 5.0 V$ , $I_{VOL} = 0$	34.5	36.5	38.5	dB
Frequency response	3	200 to 3400 Hz, relative 1kHz,	-1		1	dB
Amplifier power efficiency (5% dist), n	3	$V_A = 3.0$ to $12.0 V$ , $n = 100 \cdot P_{Load} / P_{Supply}$		40		%
Input impedance pin 23	3		24	30	36	k $\Omega$

**Notes**

1.  $20 \cdot 10 \log \left( \frac{V_{NDet} - V_{Ref}}{V_{TxDet} - V_{TxDetO}} \right)$

- $V_{NDet}$  = voltage at noise detector output
- $V_{Ref}$  = reference voltage (about 2 V) see figure 2.
- $V_{TxDet}$  = Voltage at transmit detector output.
- $V_{TxDetO}$  = voltage at transmit detector output at the point when the voltage at the noise detector starts moving when a signal at transmit channel input is gradually increased (threshold, typical value 30 mV)

2. Depends on  $V_+$ . Channels are tracking.

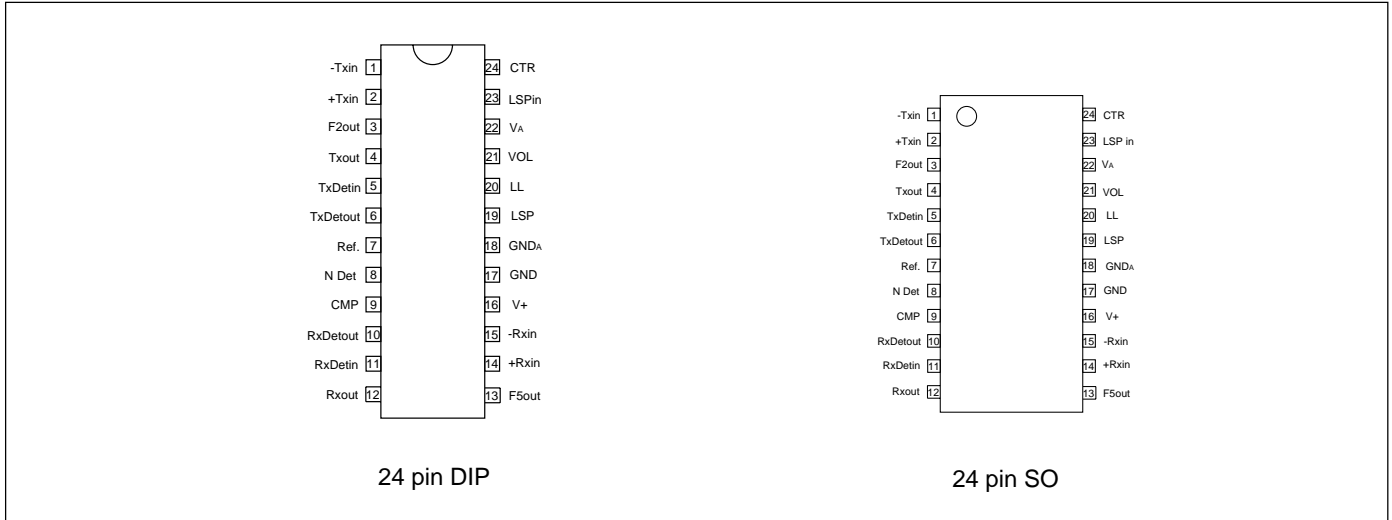

Figure 4. Pin configuration.

### Pin Descriptions

Refer to figure 6. (24 pin DIP and 24 pin SO package)

Pin	Symbol	Description	Pin	Symbol	Description
1	-Txin	Transmitter channel negative input. Input impedance 3.16 kohm.	11	RxDetin	Input of the receiver channel signal detector. Input impedance 13 kohm.
2	+Txin	Transmitter channel positive input. Input impedance 100 kohm.	12	Rxout	Receiver channel output. Min. ac load impedance 10 kohm.
3	F2out	Output of the second amplifier in the transmitter channel.	13	F5out	Output of the second amplifier in the receiver channel.
4	Txout	Transmitter channel output. Min. ac load impedance 10 kohm.	14	+Rxin	Receiver channel positive input. Input impedance 140 kohm.
5	TxDetin	Input of the transmitter channel signal detector. Input impedance 13 kohm.	15	-Rxin	Receiver channel negative input. Input impedance 20 kohm.
6	TxDetout	Output of the transmitter channel signal detector. Goes negative referred to the internal ref. voltage of appx. 2V when a transmitter signal is present.	16	V+	Supply of the speech switching circuitry. A shunt regulator, voltage apprx. 3.3V at 1.0mA.
7	Ref.	Internal reference app. 2V.	17	GND	System ground.
8	NDet	Background noise detector output. Goes positive referred to the internal ref. voltage of app. 2V when a background noise signal is present	18	GND <sub>A</sub>	Power amplifier ground. Can lie positive relative to GND, otherways connected externally to GND.
9	CMP	Comparator input. External resistance to this point should not be less than 50 kohm. Summing point to the different detector outputs.	19	LSP	Loudspeaker power amplifier output.
10	RxDetout	Output of the receiver channel signal detector. Goes positive referred to the internal ref. voltage of appx. 2V when a receiver signal is present	20	LL	Feedback loop input
			21	VOL	Volume control input. By sourcing a current of appx. 0-40 µA into this pin the gain can be reduced.
			22	VA	Positive supply for the loudspeaker amplifier.
			23	LSPin	Loudspeaker amplifier signal input. Input impedance 30 kohm.
			24	CTR	Control input for gain dynamics (25 or 50dB), mute and disable.

## Functional Description Speech control section Transmitter and Receiver Channels

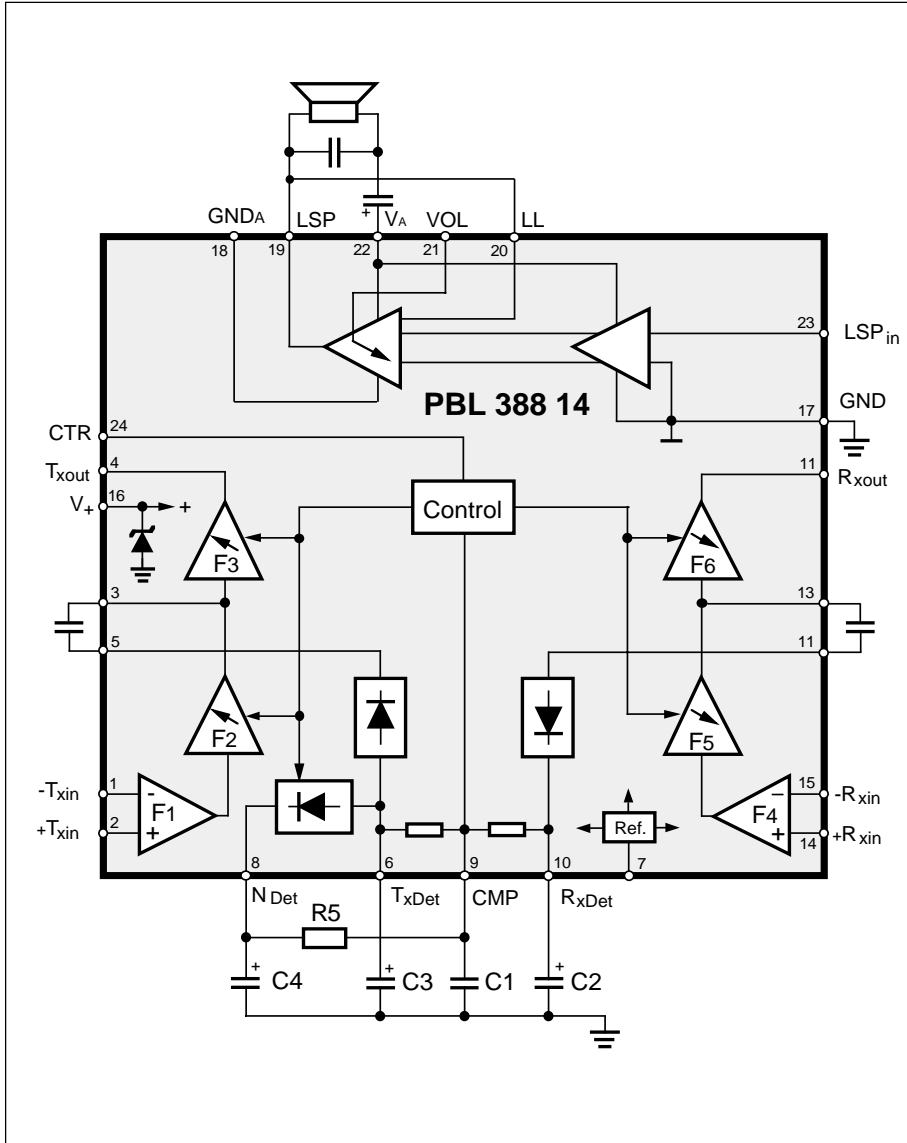

Figure 5. Passive networks setting the speech control function.

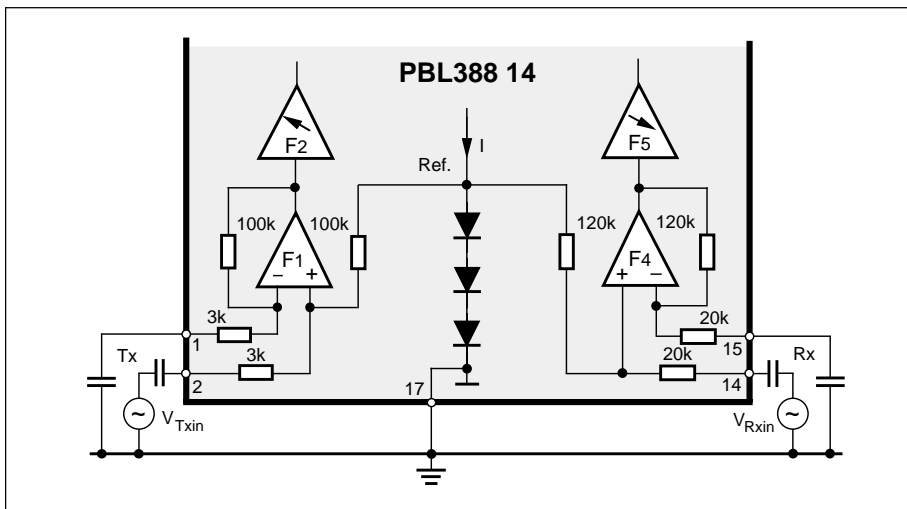

Figure 6. Receive and transmit channel input arrangement.

The transmitter and receiver channels consist of three amplifying stages each, F1, F2, F3 and F4, F5, F6. The inputs of the amplifiers must be ac. coupled because they are dc. wise at the internal reference voltage ( $\approx 2V$ ) level. F1 and F4 are fixed gain amplifiers of 29.5 dB and 15.5 dB respectively, while the rest of them are of controlled gain type amplifiers. The gain of F2, F3 as well as F5 and F6 is controlled by the comparator. Ac. loading the channel outputs F3 and F6 will lessen the dc. current consumption, maximum load 10 k $\Omega$ . The output capacity can be increased somewhat in case needed, by coupling a 10 k $\Omega$  resistor from the respective output pin directly to ground (before the optional capacitor). The comparator receives its information from the summing point of the transmitter, receiver and background noise detectors at CMP input. The control input CTR, controls the gain dynamics (25 or 50 dB). Amplifiers F2 and F3 have the maximum gain when the transmitter channel is fully open, consequently the amplifiers F5 and F6 will have minimum gain and vice versa. See figure 5 and figure 11.

The positive input on each channel has a high input impedance. It renders a good gain precision and noise performance when used with low impedance signal source. The negative input of the receiver channel should be returned to ground with a capacitor. The differential input of the transmitter channel can be used to suppress unwanted signals in the microphone supply, see figure 7. Also see application.

### Signal Detectors and the Comparator

The signal detectors sense and rectify the receiver and microphone signals to opposite polarities referenced to the internal reference voltage of approx. 2V. The voltage at RxDet will go positive and at TxDet negative in the presence of a signal at the respective channel input. In the idle (no signal) state, the voltages at RxDet, TxDet and CMP are equal to the internal reference voltage. Signal at Txin will result in a decreasing level at TxDetout and hence also at CMP input.

Figure 7. Transmitter channel input amplifier used to suppress ripple in the mic. supply. (CMRR).

$R1 = R2 \approx 3k$   
 $R3 = R4 \approx 100k$   
 $R5 = R6$   
 $C1 = C2$

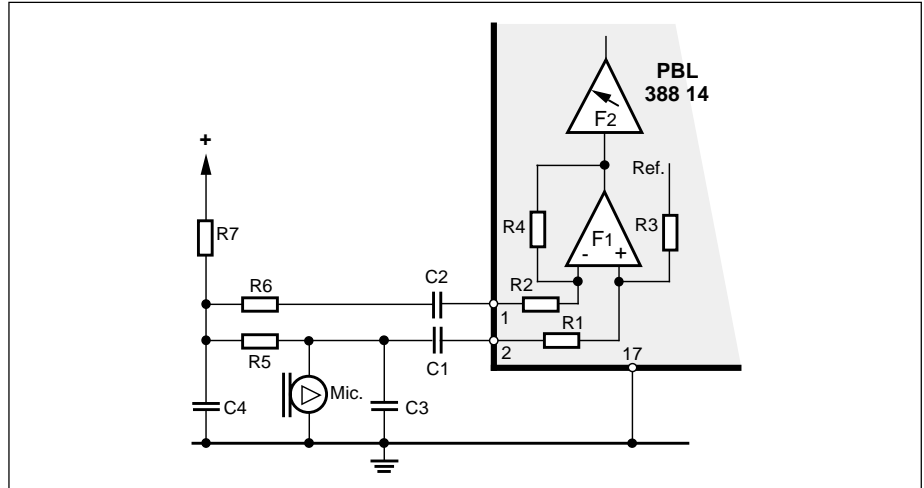

Figure 8. Transmitter and receiver channel rectifier characteristics.

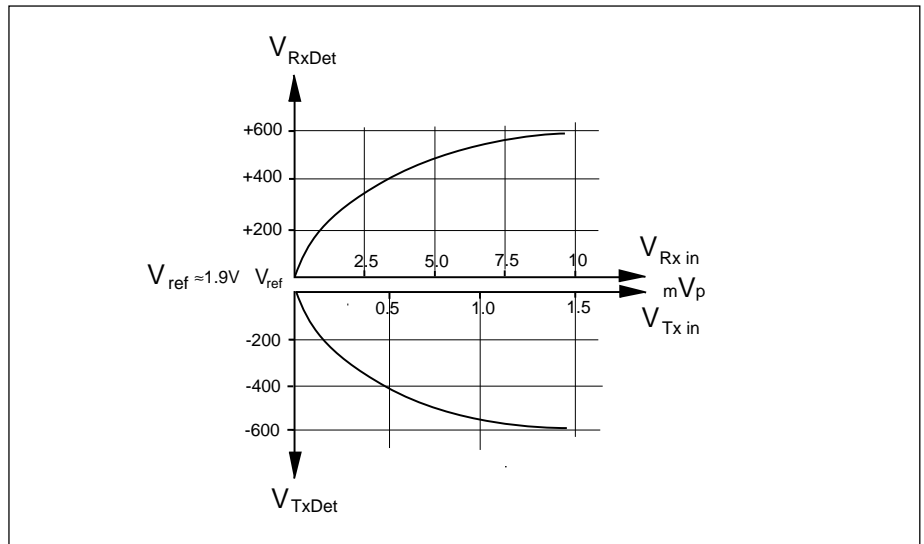

Figure 9. Relationship in timing between the voltage levels at  $Tx_{in}$ ,  $Tx_{Det}$  and  $N_{Det}$

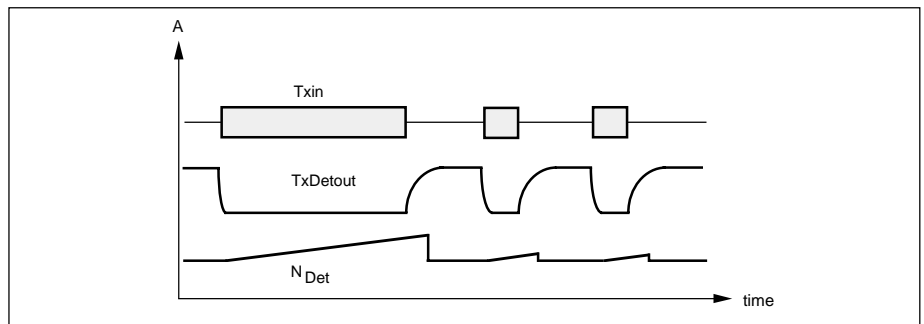
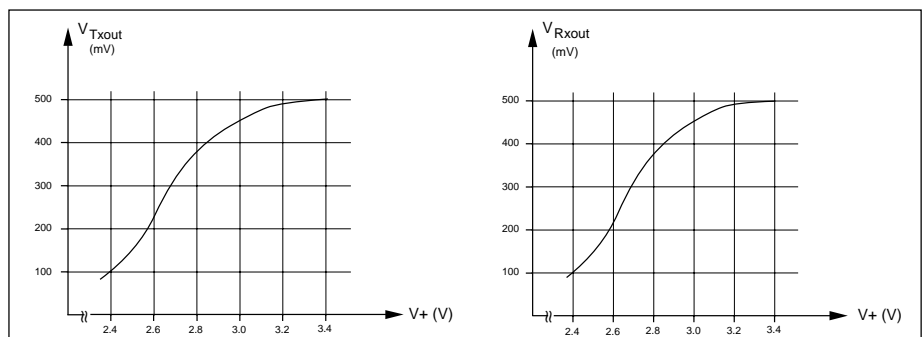

Figure 10. Transmitter and receiver channel output dynamics.



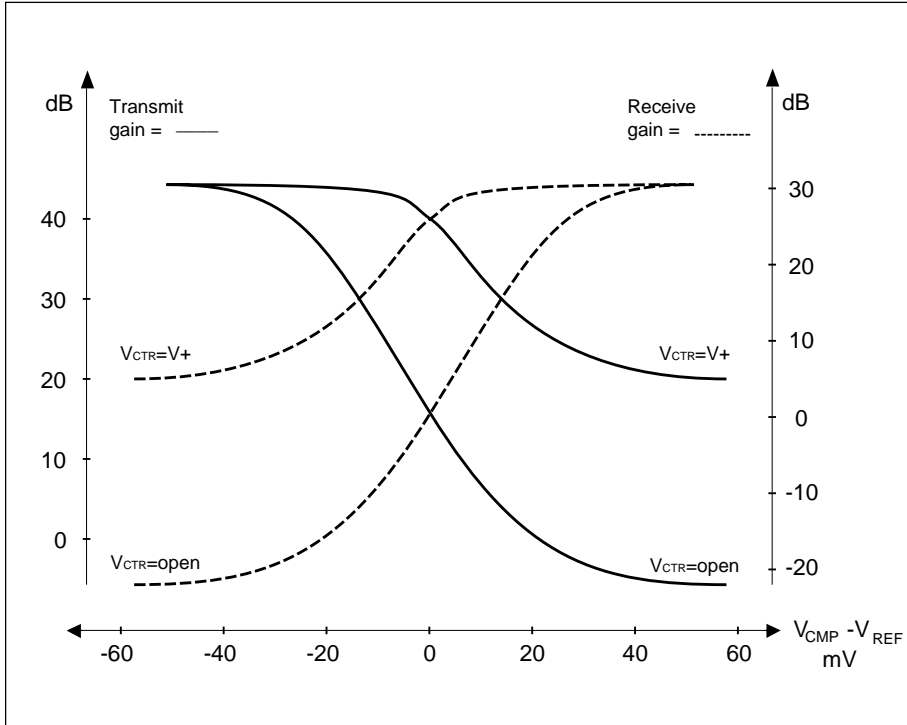

Figure 11. Transmit and receive gain as a function of  $V_{CMP}$  and  $V_{CTR}$ .

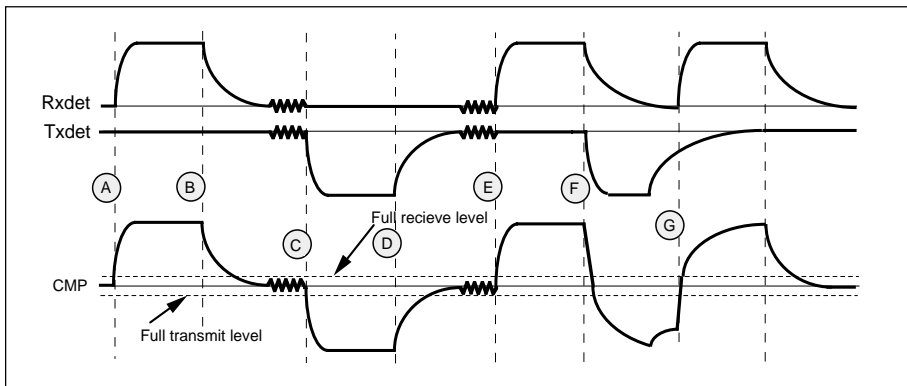

Figure 12. Timing of the transmitter and receiver channels at the CMP-input.

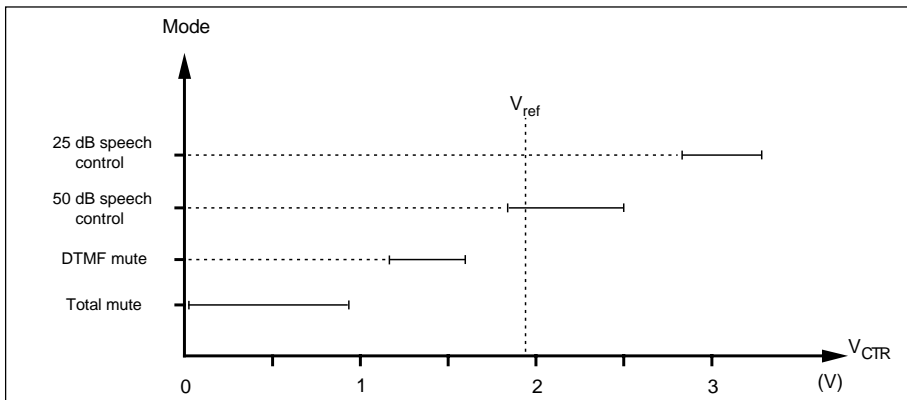

Figure 13. Control modes as function of voltage applied to gain dynamics control input  $CTR$   $I_D=1mA$

The comparator will increase the gain in the transmitter channel and decrease it in the receiver channel accordingly. Signal at  $Rx_{in}$  will do the same but vice versa. The voltages  $RxDetout$  and  $TxDetout$  control thus the gain setting in respective channel through the comparator using the  $CMP$  input as a summing point. The attack and decay times for the signals  $RxDetout$  and  $TxDetout$  are controlled by individual external RC-networks. The attack time in the receiver channel is set by  $C_2$  together with  $C_1$  and by the maximum current capability of the detector output. The time constant is altered best by altering the value of  $C_2$ . The transmitter channel works likewise. See fig. 5.

The decay time in the receiver and transmitter channels is set by  $C_2$  and  $C_3$  respectively. The resistor in the time constant is formed by an internal  $100k\Omega$  resistor. The text above describes the case when only one channel is open at a time and there is a distinctive pause between signals at receiver and transmitter channel inputs so the circuit will have time to reach its idle state. See fig.12 A) to E). If one of the channels gets an input signal immediately after the signal has disappeared from the other channel input the effective decay time, as the  $CMP$  input sees it, will be shorter than in the first case. See fig.12 F) to G). The capacitor  $C_1$  at  $CMP$  - input sets the speed of the gain change in the transmitter and receiver channels. The capacitors  $C_2$  and  $C_3$  should be dimensioned for a charging time of 0.5 - 10ms and for a discharge time of 150 - 300 ms. The question of switching times is a highly subjective proposition. It is to a large part dependent of the language being spoken in the system, this because of the varying sound pressure pattern in the different languages. A hysteresis effect is achieved in the switching since the level detectors sense the signals after  $F_2$  and  $F_5$  respectively ( $F_2$  and  $F_5$  are affected by the gain setting). For example: If the transmitter channel is open (maximum gain), a signal to keep the transmitter channel open is smaller than the signal that would be needed to open the channel when the receiver channel is open. The output swing of the level detectors is matched for variations in the supply voltage. The detectors have a logarithmic rectifier characteristic whereby gain and sensitivity is high at small signals. There is a break point in the curve at a level of  $\pm 200mV$  from the internal reference voltage ( $\approx 2V$ ), where the sensitivity for increasing input signals



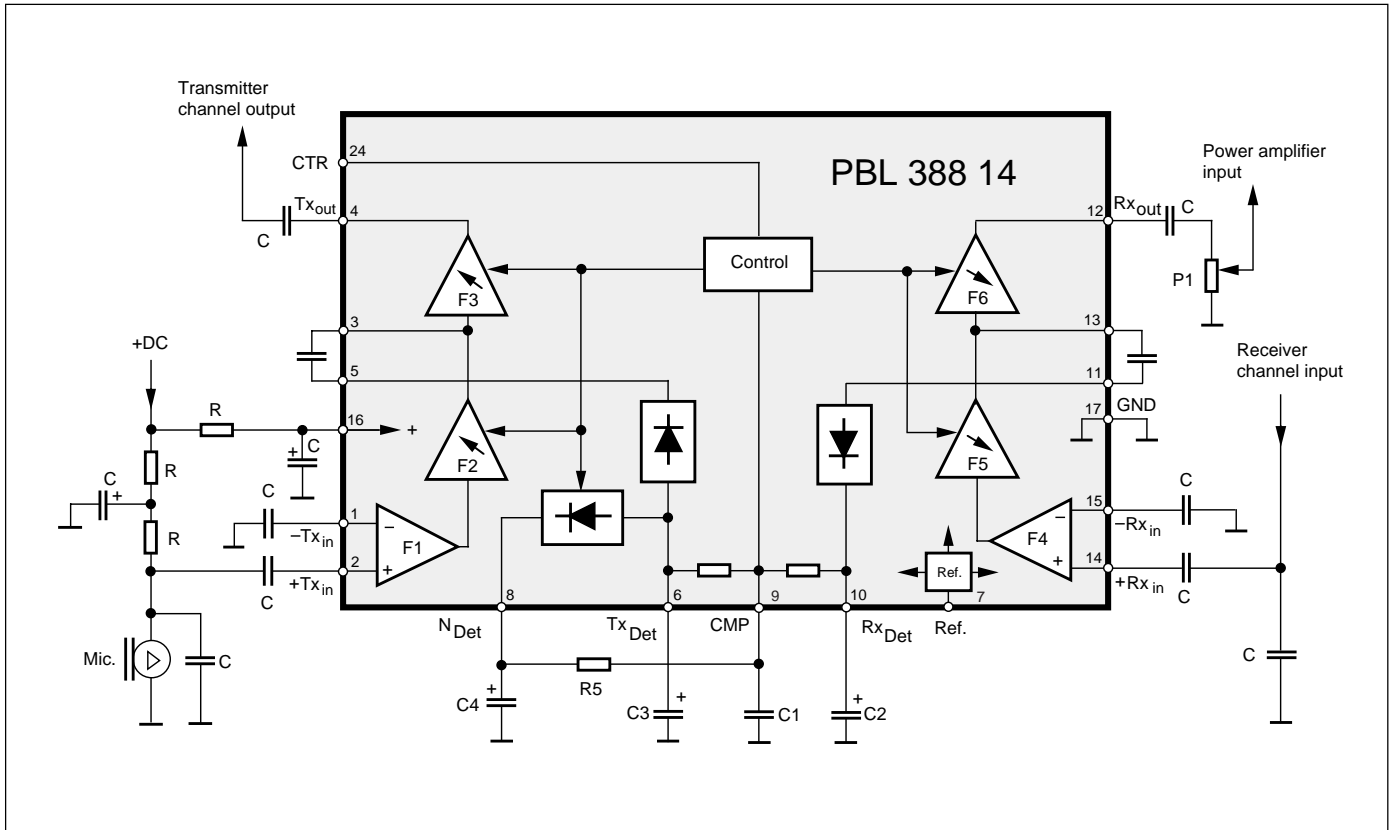

Figure 14. Speech switching arrangement.

decreases with factor of 10, thus increasing the detectors dynamic range. See fig.8.

### Background Noise Detector

The general function of the background noise detector in the transmitting channel is to create a positive signal ( in respect to the internal reference) so that, when coupled to the summing point at the CMP input, will counteract the continuous type signal from the transmitter level detector representing the actual sound pressure level at the microphone. This counteracts the noise from influencing the switching characteristics. The input signal to the back ground noise level detector is taken from the output of the transmitter detector, a voltage representing the envelope of the amplified microphone signal. The detector inverts and amplifies this signal 2 x (transmitting mode) and has on it's output a RC network consisting of an internal resistor of 100k and an external capacitor C4. The voltage across C4 is

connected to the CMP input (summing point) via a resistor R5. The extent to which the N<sub>Det</sub> output will influence the potential at CMP input is set by the gain of the detector, the maximum swing and R5. If a continuous input signal is received from the microphone (> 10sec.) the voltage across C4 is pulled positive (relative to the reference) with a time constant set by C4 to e.g. 5 sec. A continuous input signal is thus treated as noise. Since the output of the noise detector is going negative it thereby counteracts the signal from the transmitter detector and thus helping the receiver detector signal to maintain a set relation to the transmitter detector signal. If the transmitter input signal contains breaks like breath pauses the voltage at Tx<sub>Detout</sub> decreases. If the voltage across C3 gets less than the inverted voltage across C4 divided by the detector gain a rapid charge of C4 towards reference will follow (all levels referred to the reference). If the breaks are frequent as in speech the background detector will not influence the switching characteristic of the system. See fig. 9. There is a threshold of approx. 50mV at Tx<sub>Detout</sub> to prevent the

activation of background noise detection in noiseless environment. In the receiver mode some of the loudspeaker output signal will be sensed by the microphone. In order not to treat this input signal as noise, the noise detector goes into a hold state and "remembers" the level from the previous transmitting mode periode.

### CTR Input

For full speech control (50dB attenuation between the channels) this input can be left unconnected. To set the function to 25dB attenuation the input has to be higher than 600mV below V<sub>+</sub>. See figure 15. To set the circuit into a mute state (results in, reduced gain in receiver channel for the DTMF confidence tone in the loudspeaker and closed transmitter channel) a voltage below V<sub>ref</sub> has to be connected to the input. By lowering the voltage at the input below 0.9V a condition will emerge where both receiver and transmitter channels are closed. See fig. 13.

### Loudspeaker amplifier

The loudspeaker amplifier drives directly a 25-50Ω impedance loudspeaker. The single ended loudspeaker amplifier has an internal gain regulation that prevents distortion in case of insufficient supply voltage. The loudspeaker volume control can be solved in two different ways. One is to use a conventional potentiometer that will act as an ac voltage divider at the power amplifier input pin 23. The second is to control the gain of the power amplifier by dc. at pin 21. See fig.16. The controlling element can be a potentiometer or a digital control from a  $\mu$ -processor. See figure 17.

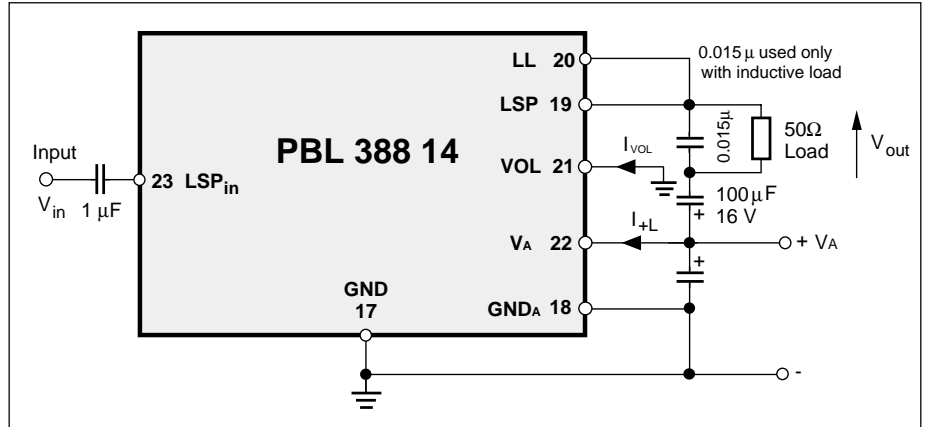

Figure 15. External power supply options.

### Some optional features using the dc. set volume control on the loudspeaker amplifier of PBL 388 14. ( Fig. 17. )

The DC set volume control has an wholly internal function to lower the gain at low supply voltages. This is to avoid that the power stage dies and causes breaks in the output signal at low supply currents in combination with high input signals. This DC controlled volume is externally accessible in the PBL 388 14 and can thus be utilized in several ways.

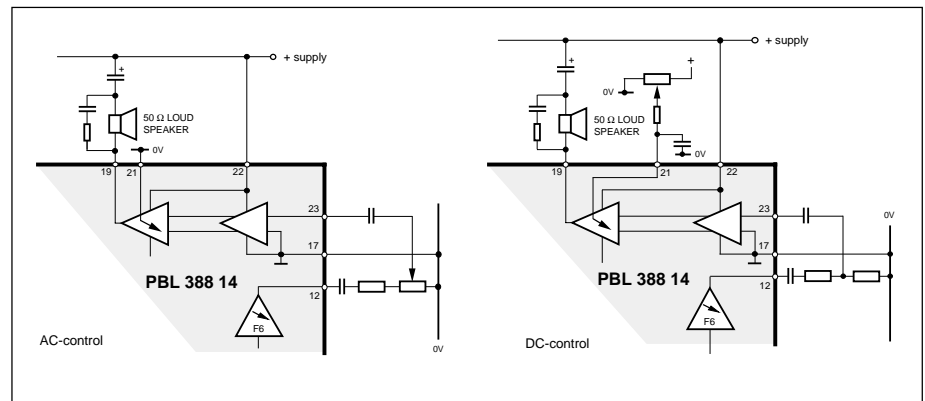

Figure 16. Loudspeaker volume control. options.

- a). To control the loudspeaker volume with a DC- voltage from a potentiometer.
- b). To control the loudspeaker volume with a digital signal ( for ex. 8 - levels ).
- c). An AGC can be combined with the volume control by connecting a resistor from the DC - control pin 21 to the output of the receiver detector at pin 10. Care has to be taken not to disturb the speech switching balance. If the resistor is made too low ohmic the same value has to be applied on the transmitter detector output at pin 6 as well as that the capacitors at the detector outputs have to be made bigger.
- d). A "softclipping" with a fixed level can be combined with the volume control. A drawback with the fixed level is that when setting it in to inhibit clipping distortion at low supply voltage, the level will not increase even if the supply voltage would allow it.
- e). A "softclipping" that is controlled by the "real" output level that means that the "softclipping" will follow the changes in the

supply voltage and will at all times give the optimum distortion limiting performance.

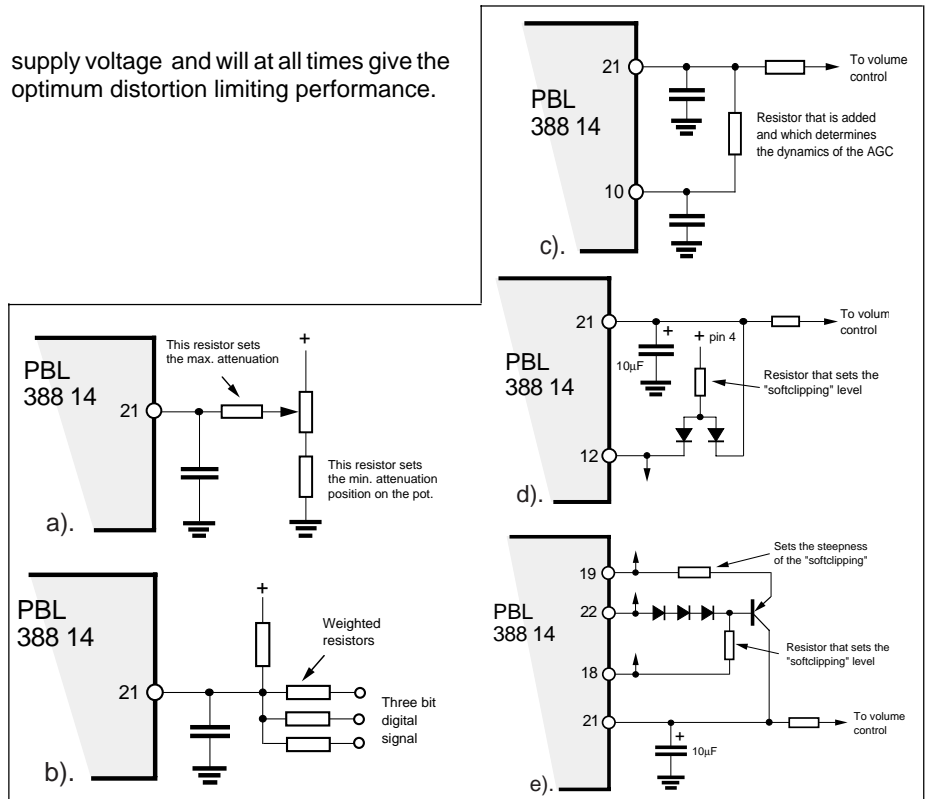

Figure 17. DC - volume control options.

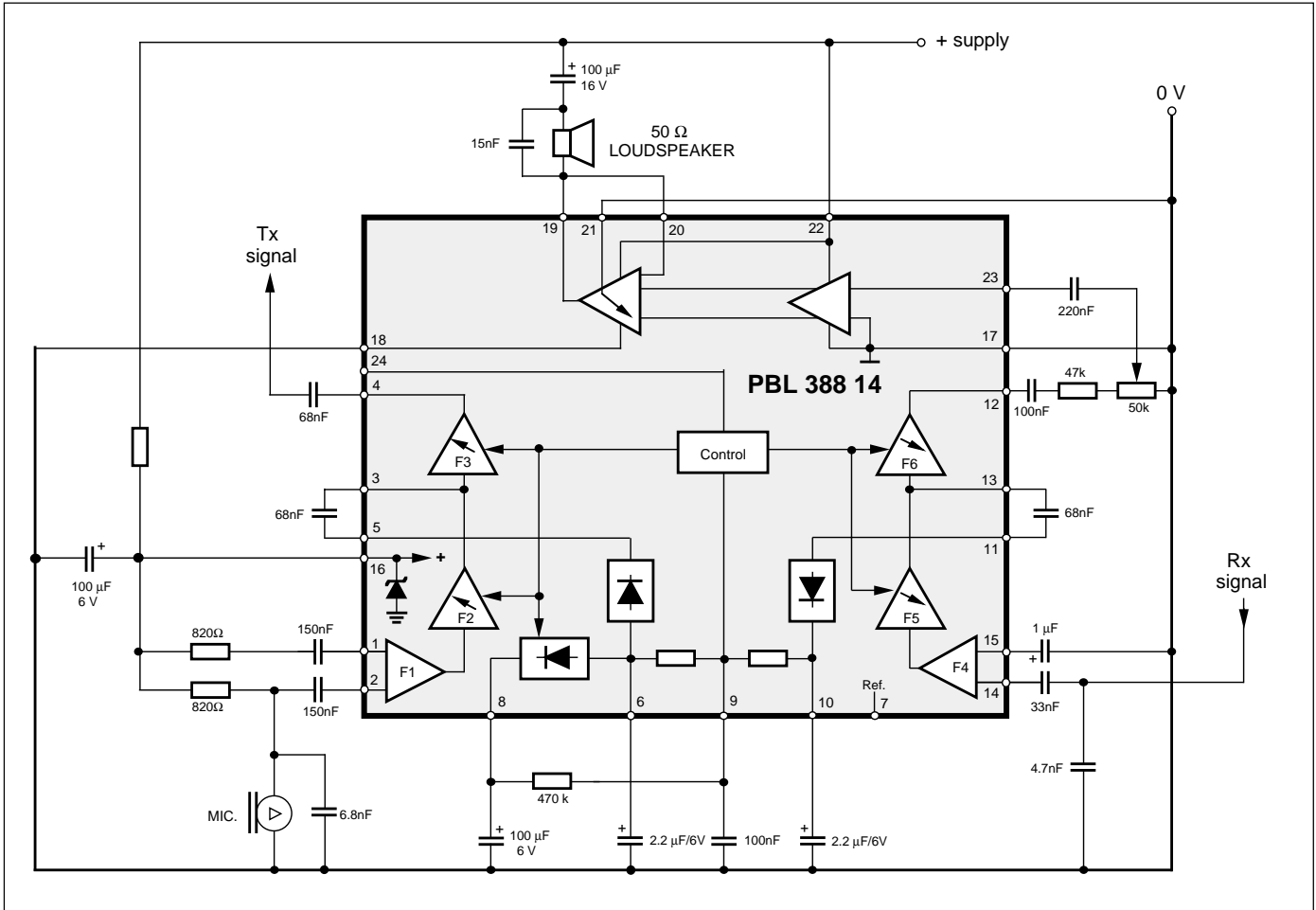

Figure 18. Application with ac. volume control.

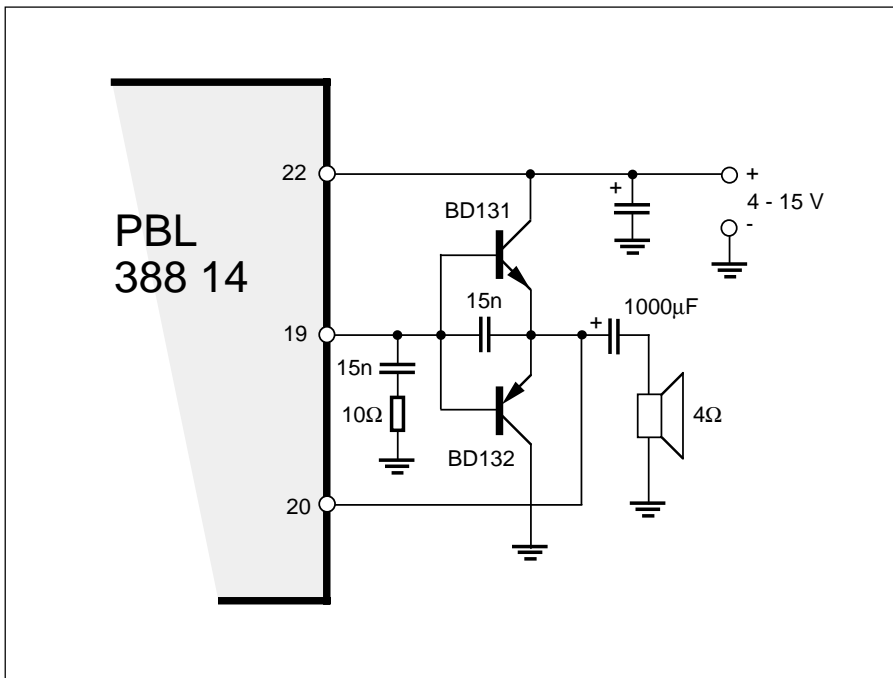

Figure 19. External power amplifier

The power amplifier feedback loop can be broken (pins 19 and 20) thus making it possible to insert external power transistors to increase the audio output power. This enables with external power supply an output power of several watts fed into 4 - 16ohm loudspeaker. See. fig. 19.

## Hints how to design a handsfree system with PBL 388 14.

To design the speech control function, seven different signal paths have to be considered and understood. See fig. 28.

### The signal paths:

**G1** is the acoustic signal into the microphone, further transformed to an electrical signal in an amplifier which gain can be controlled 12,5 dB up or down from an idle point, further to a point where it is rectified to a negative signal and compared with its counterpart from the receiver channel.

**G2** is the corresponding signal to G1 on the receiver side. The signal from the line that goes via the sidetone balancing network and an amplifier which gain can be

controlled 12,5 dB up or down from an idle point, further to a point where its rectified to a positive signal and compared with its counterpart from the transmitter channel.

**G3** starts the same as G1 but does not go to the rectifier, instead passes through further an amplifier which gain can be controlled 12,5 dB up or down from an idle point, further to the transmitter of the speech circuit and out on the telephone line.

**G4** is the corresponding signal to G3 on the receiver side. Starts the same as G2 but does not go to the rectifier, instead passes through further an amplifier which gain can be controlled 12,5 dB up or down from an idle point, via loudspeaker volume control, loudspeaker amplifier and out as

an acoustic signal of the loudspeaker.

**G5** starts the same way as G4 ends. From the receiver rectifier through loudspeaker amplifier, loudspeaker, acoustic signal path (loudspeaker - microphone) and is terminated, like G1, at transmitter rectifier.

**G6** is the corresponding signal to G5 but goes through the sidetone network. Starts the same way as G3 ends. From the transmitter rectifier, amplifier via speech circuit transmitter, sidetone balancing network and the line, to be terminated at receiver rectifier like G2.

**G7** is the closed loop signal that can be considered to start or end at any point in the loop. The summ of G5 and G6.

Figure 20. Schematic diagram of the various signal paths that affect on the design of a handsfree telephone.

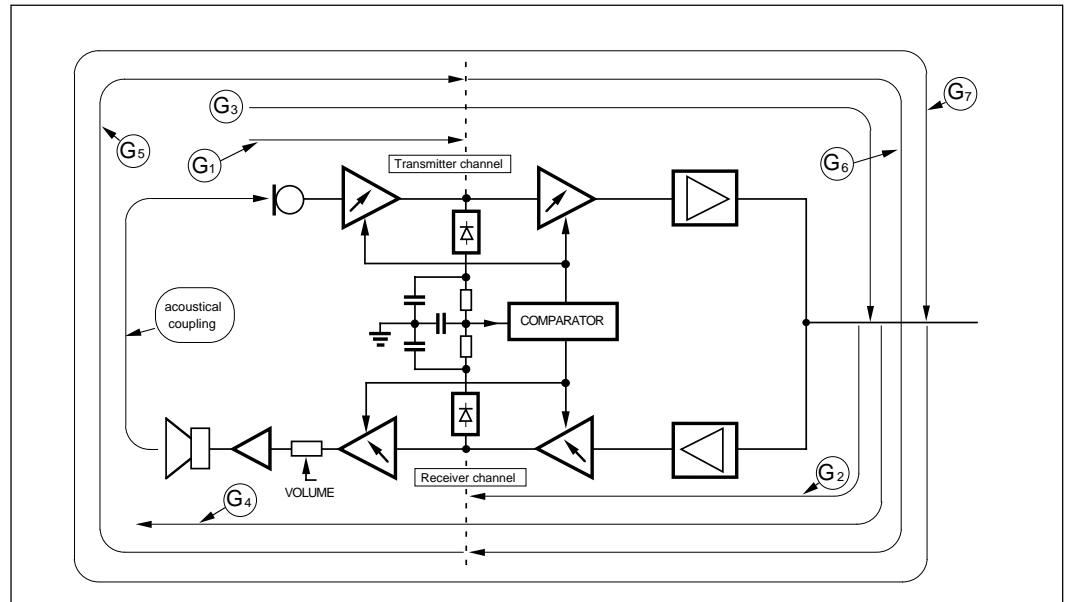

### General:

The first thing that comes into ones mind when looking at a "handsfree" solution like the one with PBL 388 13 is, that it must be able to prevent oscillation in the closed loop G7. The circuit does this by having 50 dB less gain in the opposite direction against the open channel this being either the receiving or transmitting direction. Nor does it oscillate when having proper gain values, sidetone balance, loudspeaker volume and small acoustical coupling between the loudspeaker and microphone. Actually, one needs a lot of margin against oscillation so that no positive feedback is created in the loop G7. This would destroy the frequency characteristic through the increasing gain at the "would oscillate frequency" in case of somewhat higher gain in the loop. The speech would

sound harsh. This is normally not the most difficult requirement on the gain in the G7 loop. The most difficult requirement is set by the telephone set impedance towards the line. The signal originates from the line, rounds the loop G7 and enters the line again. This way the impedance of the telephone set towards the line is influenced by the gain in the loop G7. The impedance of the telephone towards the line has to be measured in the "handsfree" mode under correct acoustical circumstances and at maximum loudspeaker volume.

A major problem in many cases is the acoustical coupling between loudspeaker and microphone. The telephone designer gets often an order to fit a "handsfree" telephone system into a fully unsuitable ready made casing. The design

of a "handsfree" telephone with a speech control starts with the acoustical design of the casing. PBL 388 14 makes a good acoustical design to sound as close a perfect "handsfree" as it is possible. This means that there are no audible switching noises and speech is conveyed in one direction at the time. In opposite case having a bad acoustical design with a large coupling between the loudspeaker and the microphone, no electronics in the world, using the speech switching principle, can make it to sound good. Why, will be studied later.

### Acoustic design:

Any amount of time can be spent on the acoustic design. It depends largely if the task is to make a "just working handsfree" telephone or to make the best

possible. If a simple telephone casing is considered, it could be a box with a large hole for the loudspeaker and a small hole for the microphone. This would normally not function. The acoustical coupling would be much too high. Three different acoustical signal paths are apparent. The first through the air outside the casing, damped best by observing that the signal has no direct path or can be reflected for ex. by a hard table surface from the loudspeaker to the microphone. The second path inside the casing can be best minimized by designing both the loudspeaker and the microphone into individual compartments only open to the outside world. The third path would be the one through the material of the casing. The simplest counter measure is to mount the microphone in soft shock and sound absorbing material, the same goes also for the loudspeaker. There are a number of other, besides these, principal requirements on the acoustical coupling between loudspeaker and microphone. One being to make the microphone sensitive for the user so that the gains in the paths G1 and G3 can be made low, furthermore to get it such that the room acoustics do not disturb. The speech switching helps in this regard quite a bit by having the loudspeaker damped in the transmitting mode and the microphone damped in the receiving mode which makes that the other party at the other end of the telephone line will not get disturbed by hearing his own voice.

### **Dimensioning of signal paths G1 to G6.**

The +input of the receiver channel is connected to the receiver signal output at the sidetone network either via a capacitor or a filter. Signal path G2. The sensitivity is made to suit directly. If clipping of signal is experienced in the channel the signal must be attenuated at the input. A high sensitivity is desired to have the speech switching working at low signal levels thus being inaudible, where at the same time the receiver input has to function with high dynamic range. The differences in input signal levels can be 20 dB or more.

The maximum receive gain is set by a resistor in series with the ac. volume control. This ends the dimensioning of the path G4.

The signal from the microphone is coupled via a capacitor to the transmitter channel +input. The wanted sensitivity in the signal path G1 is set by the current feeding resistor to the microphone. A balance between the signals in both

channels reaching their detectors should be attained. This can be studied with a two channel oscilloscope one channel attached to each "handsfree" channels detector output. The volume control should be at maximum setting and the study should be made with different signal levels and insinals at both microphone and from the line.

The final study should take place when even the signal from the transmitting channel with suitable attenuation is coupled to the speech circuit transmitter. This completes the signal path G3 and sets the transmitting gain from the microphone to the telephone line. What can be studied here is, that the in signal at the receiver causes in many cases a signal at the transmitter detector. This is the signal path G5. In a good design this signal path must be well damped. If the signal G5 itself reaches to same level of outsignal as the insignal there is a risk that the system switches itself to transmitting instead of receiving which results in a pulsating tone. In a good quality "handsfree" telephone this kind of behaviour must be solved by decreasing the acoustic coupling between loudspeaker and microphone. In a budget type of telephone other solutions may have to be considered like lowering the maximum gain in the receiver by means of higher series resistor with the ac. volume control or to unbalance the detectors slightly with lower gain in G1 (naturally with less attenuation to the transmitter of the speech circuit in order to keep the G3 constant). Same kind of crosstalk exists also in the opposite case ( signal path G6) but the sidetone balancing can normally be made that good to prevent this signal path to cause problem.

### **Dimensioning of filter:**

The inputs of transmitter and receiver amplifiers ought to have simple filters according to the application in order to be able to set and limit the frequency behaviour. More complex filters can be applied at the detector inputs. In the application used are Only low frequency limiting coupling capacitors are used in the application, this is adequate in most of the cases.

### **Dimensioning of time constants:**

The charging time of the detectors (negative for the transmitter, positive for the receiver) is determined by the drive capacity of the rectifier and the size of the external capacitor. The speed of the charging (attack) is highly due to a personal feeling, also somewhat dependent of the language at hand and can be set by the capacitor at the respective detector output. Even the dis-

charge (decay) time can be altered by high ohmic resistors from the respective detector output to + supply or to ground. The values in the application serve as a good starting point. The capacitor at the comparator input that sets the switching speed can also be varied one or two values up or down in order to get a good "feeling" for the system. The question of the system quality is an extremely subjective proposition and is based on subtle differences. What is right or wrong in the end is hard to tell.

### **Transmitter or receiver priority:**

There is sometimes a requirement of either transmitter or receiver priority of the speech switching. This means that the speech switch will not rest at idle position, in (no signal in either channel) condition, but is biased towards either of the channels. This requirement is usually coupled to some special features but is also used in "primitive" handsfree phones where the transmitter priority will make it to sound better for the other party and saves him from suffering that the first party has a bad handsfree phone. The reason for receiver priority is more difficult to comprehend, maybe that the buyer will be given a feeling that he got more value for his money by hearing the other party better. Priority is an unwanted feature while ruining the speech switching balance, it can be introduced in lesser or greater degree on the PBL 388 13. A high ohmic resistor from +supply to the comparator input will move the system towards receiver priority where a high ohmic resistor from the comparator input to ground will move the system towards transmitter priority.

### **Background noise compensation:**

There is a detector at the transmitter rectifier that senses continuous signals like fan noise or noise from many people. In case the function it is not required the external components at its output are simply omitted. In case the function is required an integration capacitor is coupled from the output to ground and a resistor from the output to comparator input. This resistor determines the amount of compensation. Care has to be taken in order not to over compensate by making the resistor too small, it can result in hook-up phenomena. By setting the system in slightly under compensating mode will help the balance in the speech

switching a lot if the telephone is placed in a noisy surrounding. It can not be required that the other party has to know that he is talking with somebody with a handsfree telephone in a noisy environment and thus has to shout to get through.

The circuit has no corresponding function in the receiver channel in fear that it would only worsen the performance. The reason for this is that various tone signals on the line are difficult to detect and to separate because of the big level differences. A normal behaviour would be that when one receives a high noise level from the loudspeaker one automatically rises ones own voice and compensates for the noise in the other end thus functioning as a noise compensation for the receiver. There is a risk that the loudspeaker volume would be turned down but in that case it would be difficult to hear the other party from the noise.

Something that can be tried in a "sophisticated" handsfree telephone is, to let the volume control influence the gain slightly also at the input of the receiver.

The circuit does not contain any automatic volume controls ( type AGC). These kind of functions can of course be included externally to the inputs of the receiver and transmitter but it is very difficult in this way to better the performance. The speech switching is based to feel differences in signal levels where again the automatic volume controls are working to keep the levels constant. This results in almost unsolvable problems with time constants if these two systems are combined. It is not even certain that automatic volume controls are desirable. If one stands on the other side of the room, where the telephone is placed, facing it, one automatically rises ones voice the

same way as one would do when speaking with somebody standing further away. On the receiver side we have a volume control to set the desired level.

### Loudhearing:

By setting the CTR control input high with a resistor to +supply the circuit will go into half speech control mode. The amplifiers in the other half of the signal paths G3 and G4 will be set into maximum gain constantly. This does not alter anything in the speech control function because the hysteresis function is set by the other two controlled amplifiers. The purpose with this is to lead the signal from the handset microphone via the speech control transmitter channel and disconnect the "handsfree function". If the loudhearing mode is active with the loudspeaker on, there will be no oscillation when the handset is placed close to the loudspeaker which would be the case in normal mode when lifting and returning the handset. Because the microphone in the handset has lower sensitivity related to the handsfree microphone, the 25 dB speech control that is used, is enough to counteract oscillation. There are other solutions to this problem but none has the same speech quality than this one. This speech control is needed so that the party in the other end of the telephone line will not be disturbed by the echo of his own voice, which can be extremely disturbing.

### The efficiency of the loudspeaker power amplifier.

The PBL 388 13 has an extremely high efficiency when it comes to convert the existing line current to loudspeaker output power. It is possible to make a telephone line fed "handsfree" telephone with just under 10 mA of line current. The current that is taken for the loudspeaker

power amplifier supply is set by resistor at pin RE. The value of this resistor should not be made so low that the speech circuit will at any time "current starve" as this would cause high distortion on the line. Because this kind of current feed system is a co-operation between the speech circuit and the power amplifier of the "handsfree circuit", it will only function properly with Ericsson speech circuits except circuits PBL3726/21 or PBL3853. (The two last named circuits could feed the power amplifier from the special supply they are both providing). The voltage increases with increasing line current across the resistor RE, which results in, that optimum current is taken at all line currents. The current is fed into a reservoir capacitor between -C and +L. The power amplifier is grounded at the positive rail, this to avoid that the ground would have a small level shift in case the -L is used for ground. A level difference in the ground between the circuits can cause serious trouble in regard of RFI. Everything is ground related to the two possible points, those being the two telephone wires. The reservoir capacitor is chosen between 470 - 2200µF dependent on price contra efficiency. Because the speech has a highly varying amplitude a big capacitor will save energy to the real high amplitude peaks. The power amplifier is a simple output stage in order to render maximum efficiency. A balanced output stage would only lead to much increased loudspeaker impedance, which is already with a simple stage in the highest order. The optimum loudspeaker impedance is dependent on many factors like the available voltage and current, if the optimization is done against RMS value or more towards speech like low RMS value but with some high peaks. The optimum loudspeaker impedance for RMS calculus will be round 50 ohms, for speech ( music power ) a 25 ohm loudspeaker is more optimal and if it can be considered that it is long time between the peaks, even a 16 ohm loudspeaker can be used.

Information given in this data sheet is believed to be accurate and reliable. However no responsibility is assumed for the consequences of its use nor for any infringement of patents or other rights of third parties which may result from its use. No license is granted by implication or otherwise under any patent or patent rights of Ericsson Components AB. These products are sold only according to Ericsson Components AB's general conditions of sale, unless otherwise confirmed in writing.

Specifications subject to change without notice.

1522-PBL 388 14 Uen Rev.A  
© Ericsson Components AB  
May 1998

**ERICSSON** 

Ericsson Components AB  
S-164 81 Kista-Stockholm, Sweden  
Telephone: (08) 757 50 00

## Ordering Information

Package	Temp. Range	Part No.
Plastic DIP	-20 to 70°C	PBL 388 14/1N
Plastic SO	-20 to 70°C	PBL 388 14/1SO
Plastic SO	-20 to 70°C	PBL 388 14/1SO:T (Tape and Reel)