

## SC14425 Complete Baseband processor for DECT Base Stations with Caller-id and Handsfree

### General Description

The SC14425SC14425 is a 3.3 Volt CMOS IC optimized to handle all the audio, signal and data processing needed within a DECT base station. An ADPCM transcoder, a very low power 14 bit Codec and Analog Frontend are integrated. Direct connections towards analog or ISDN line interface.

The SC14425 has an on-chip dedicated flexible DSP optimized for telecom applications caller-id, handsfree and allows easy connection to digital telephone answering machine devices.

The SC14425 is designed to be compatible with many radio interfaces. A dedicated TDMA controller handles all physical layer slot formats and radio control. The integrated National Semiconductor's standard CR16B processor core takes care of all the higher protocol stack. Programmable I/O ports can be configured as chip selects for I/O expanders, Serial Flashes, interrupt source or I/O. A digital serial interface can be configured to interface to industry-standard codecs and ISDN devices with  $\mu$ -Law, a-Law, linear or transparent data formats.

### Features

- Integrated DECT base band transceiver optimized for GAP base stations according to ETS 300 175-2,3 & 8.
- 2.7 to 3.3 Volt operating voltage.
- Embedded 16 bit CompactRISC™ CR16B Microprocessor with In System Emulation (ISE) mode.
- On-chip 6kByte Data Memory.

- Embedded flexible dedicated DSP executing Caller-id (CID), Caller-id on Call Waiting (CIDCW) and hands-free, two echo cancellers, two echo suppressors, extended DTMF detection, DTMF generation, sidetone and artificial echo loss.
- Two full duplex 32 kbits/sec ADPCM transcoder.
- On-chip Dedicated Instruction Processor (DiP) for all TDMA based events, which supports 1.152MHz, 0.576MHz and 0.288MHz data rates.
- Protected and unprotected full and double slot B-fields
- Standard DECT encryption with different keys for different MAC-connections.
- At least 6 MAC connections can be handled simultaneously.
- Flexible three wire interface to radio front synthesizer.
- One 14-bit linear CODEC with programmable gain
- Peak hold ADC for RSSI measurement
- Two input 8 bit successive approximation ADC.
- Three general purpose I/O ports with programmable interrupts
- Full duplex UART, SPI™ and MICROWIRE™ interface.
- Flexible 8 kHz synchronous Serial interface to external codecs and ISDN interface circuits.
- Two general purpose timers and watch dog timer.
- Programmable chip selects to 8 bit wide ROM, SRAM NAND Flash Memory and I/O expanders.
- Two Capture timers for frequency measurement for e.g. metering, ringing and call progress tone detection.
- 100 pin TQFP-100 package.

**Note 1:** CompactRISC™ is a trademark of National Semiconductor Corporation, SPI™ is a trademark of Motorola.

### System Diagram

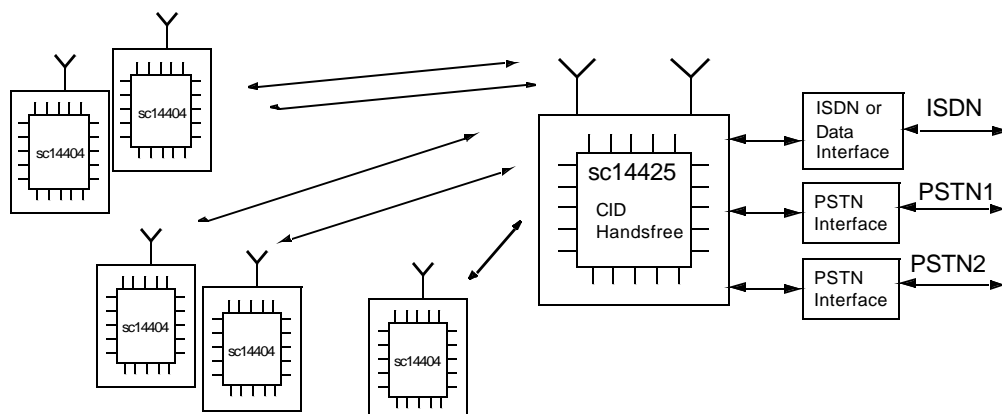

# 1.0 CONNECTION DIAGRAM

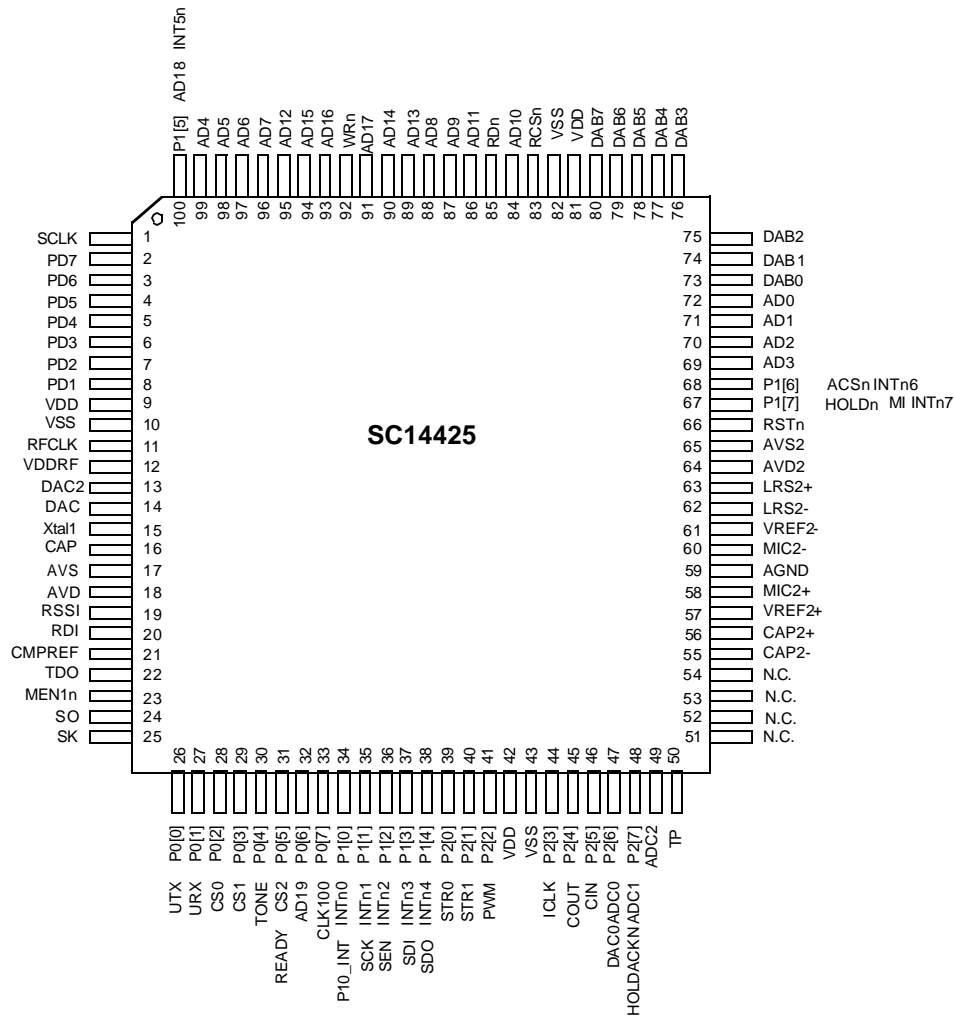

**Order Number SC14425XVJG (Standard version)**  
**X=silicon revision**  
**See NS Package Number VJG100A**

**Note 1:** All digital outputs can sink/source 2 mA unless otherwise specified. All digital inputs are Schmitt trigger types. After reset all I/Os are set to input and all pull-up or pull-down resistors are enabled unless otherwise specified.

PU = Pull-up resistor enabled, PD = Pull-down resistor enabled, I = input  
 A-I, B-I = In Boot mode A or B input and pull-up or pull-down resistor disabled,  
 A-PD, B-PU = In Boot mode A, Pull-down resistor enabled. In Boot mode B, pull-up resistor enabled.

**Note 2:** Reset state of address and WRn, RDn pins:  
 Hi-Z/1 means Hi-Z if RSTn is LOW, if RSTn goes HIGH it takes 32 SCLK cycles = 25 usec before these pin drives a '1'.

**Note 3:** 5 Volt protection pads: type \*P may NOT be connected to an external pull down resistor

# SC14425 Complete Baseband processor for DECT Base Stations

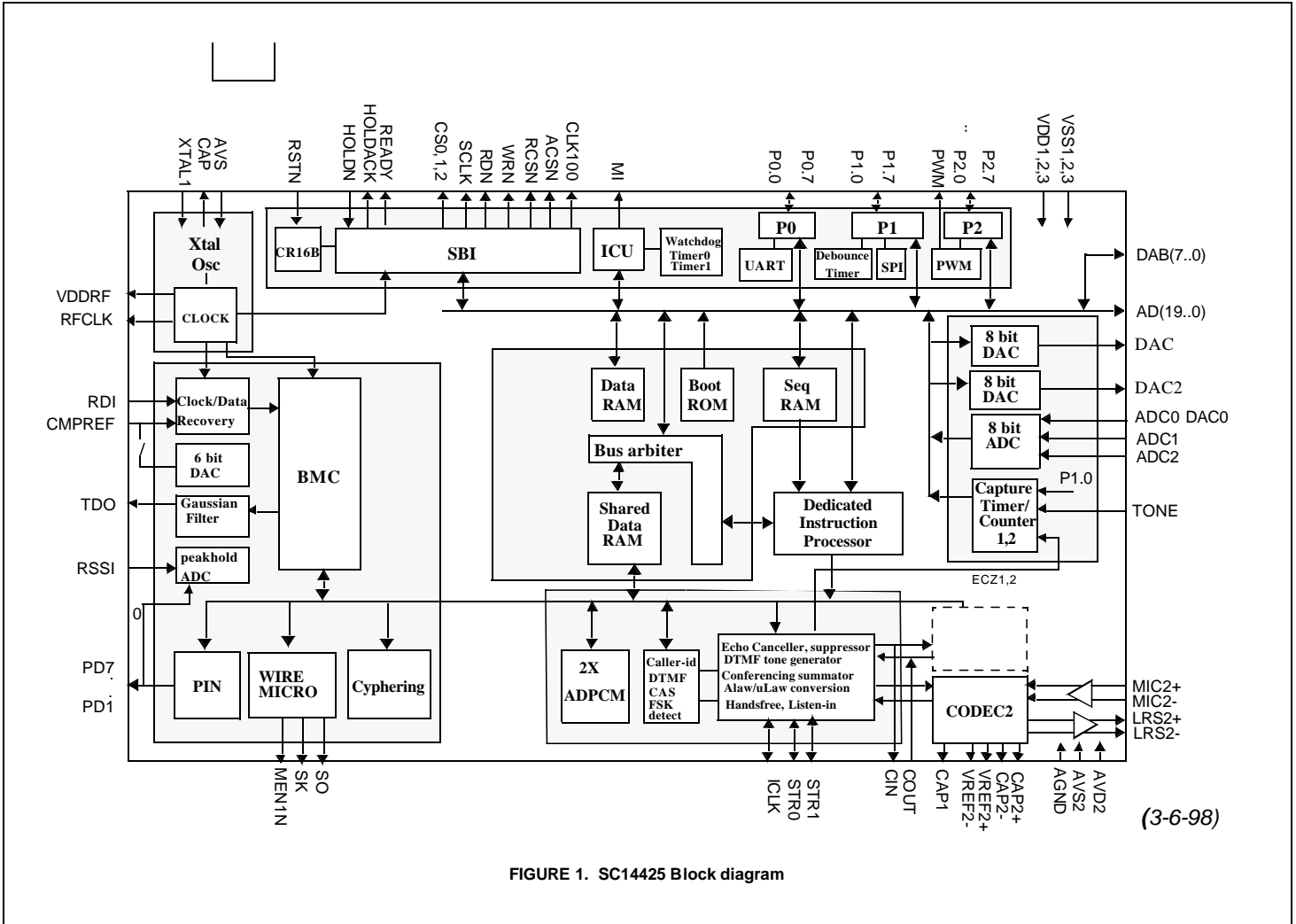
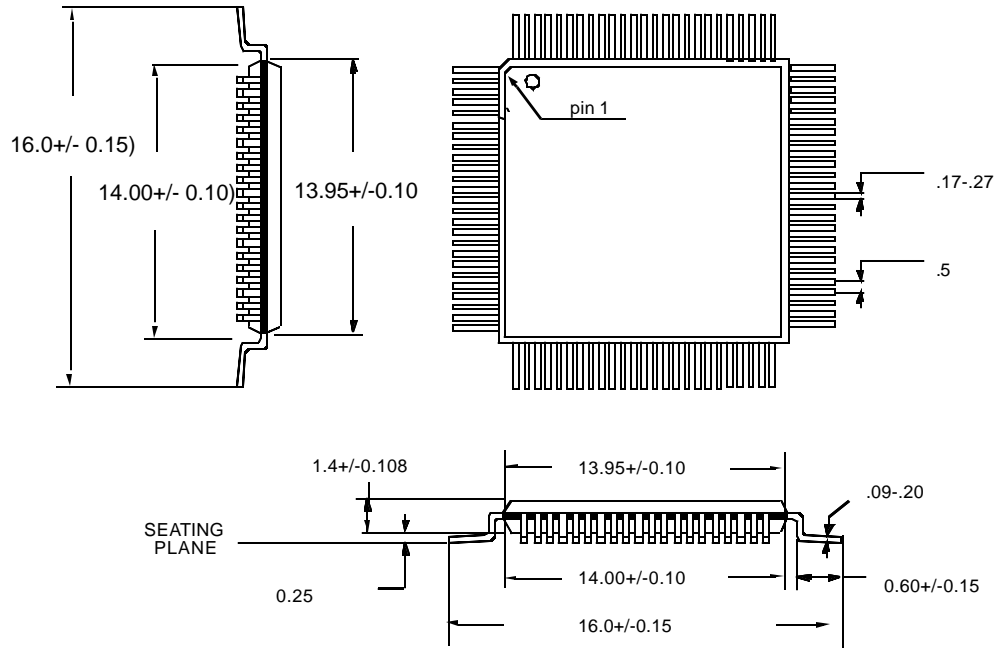

FIGURE 1. SC14425 Block diagram

(3-6-98)

1.0 Package information



4220180

FIGURE 1. 100 pins TP Quad Flat Pack. NS Package Number VJG100A

## 2.0 Product status definitions

### Definition of Terms

Data Sheet Identification	Product Status	Definition
Advance Information	Formative or In Design	This data sheet contains the design specifications for product development. Specifications may change in any manner without notice.
Preliminary	First Production	This data sheet contains preliminary data. Supplementary data will be published at a later date. National Semiconductor Corporation reserves the right to make changes at any time without notice in order to improve design and supply the best possible product.
No Identification Noted	Full Production	This data sheet contains final specifications. National Semiconductor Corporation reserves the right to make changes at any time without notice in order to improve design and supply the best possible product.
Obsolete	Not In Production	This data sheet contains specifications on a product that has been discontinued by National Semiconductor Corporation. The datash-eet is printed for reference information only.

National Semiconductor B.V reserves the right to make changes without notice to any products herein to improve reliability, function or design. National does not assume any liability arising out of the application or use of any product or circuit described herein; neither does it convey any license under its patent rights, nor the right of others.

### LIFE SUPPORT POLICY

NATIONAL'S PRODUCTS ARE NOT AUTHORIZED FOR USE AS CRITICAL COMPONENTS IN LIFE SUPPORT DEVICES OR SYSTEMS WITHOUT THE EXPRESS WRITTEN APPROVAL OF THE PRESIDENT OF NATIONAL SEMICONDUCTOR CORPORATION. As used herein:

1. Life support devices or systems are devices or systems which, (a) are intended for surgical implant into the body, or (b) support or sustain life, and whose failure to perform, when properly used in accordance with instructions for use provided in the labeling, can be reasonably expected to result in a significant injury to the user.
2. A critical component is any component of a life support device or system whose failure to perform can be reasonably expected to cause the failure of the life support device or system, or to affect its safety or effectiveness.



**National Semiconductor Corporation**  
 Tel: 1-800-272-9959  
 Fax: 1-800-737-7018  
 Email: support@nsc.com

**National Semiconductor Europe**  
 Fax: (+49) 0-180-530 85 86  
 Email: europe.support@nsc.com  
 Deutsch Tel: (+49) 0-180-530 85 85  
 English Tel: (+49) 0-180-532 78 32

**National Semiconductor Asia Pacific Customer Response Group**  
 Tel: 65-254-4466  
 Fax: 65-250-4466  
 Email: sea.support@nsc.com

**National Semiconductor Japan Ltd.**  
 Tel: 81-3-5620-6175  
 Fax: 81-3-5620-6179