



TEA1753T

GreenChip III SMPS control IC

Rev. 01 — 4 March 2011

Objective data sheet

1. General description

The GreenChip III is the third generation of green Switched Mode Power Supply (SMPS) controller ICs. The TEA1753T combines a controller for Power Factor Correction (PFC) and a flyback controller. Its high level of integration allows the design of a cost-effective power supply with a very low number of external components.

The special built-in green functions provide high efficiency at all power levels. This applies to quasi-resonant operation at high power levels, quasi-resonant operation with valley skipping, as well as to reduced frequency operation at lower power levels. At low power levels, the PFC switches off to maintain high efficiency.

During low power conditions, the flyback controller switches to frequency reduction mode and limits the peak current to an adjustable minimum value. This will ensure high efficiency at low power and good standby power performance while minimizing audible noise from the transformer.

For no-load operation, the controller can be switched to the power down mode. In this mode the controller is shutdown for very low standby power applications.

The TEA1753T is a MultiChip Module, (MCM), containing 2 chips. The proprietary high voltage BCD800 process which makes direct start-up possible from the rectified universal mains voltage in an effective and green way. The second low voltage Silicon On Insulator (SOI) is used for accurate, high speed protection functions and control.

The TEA1753T enables highly efficient and reliable supplies with power requirements of up to 250 W to be designed easily and with a minimum number of external components.

Remark: It should be noted that all values provided throughout the running text, are typical values unless otherwise stated.



2. Features and benefits

2.1 Distinctive features

- Integrated PFC and flyback controller
- Universal mains supply operation (70 V AC to 276 V AC)
- Dual boost PFC with accurate maximum output voltage (NXP patented)
- High level of integration, resulting in a very low external component count and a cost-effective design
- Adjustable PFC switch-off delay

2.2 Green features

- On-chip start-up current source
- Power down functionality for very low standby power

2.3 PFC green features

- Valley/zero voltage switching for minimum switching losses (NXP patented)
- Frequency limitation to reduce switching losses
- PFC is switched off when a low load is detected at the flyback output

2.4 Flyback green features

- Valley switching for minimum switching losses (NXP patented)
- Frequency reduction with adjustable minimum peak current at low power operation to maintain high efficiency at low output power levels

2.5 Protection features

- Safe restart mode for system fault conditions
- Continuous mode protection by means of demagnetization detection for both converters (NXP patented)
- UnderVoltage Protection (UVP) (foldback during overload)
- Accurate OverVoltage Protection (OVP) for both converters (adjustable for flyback converter)
- Mains voltage independent OverPower Protection (OPP)
- Open control loop protection for both converters. The open-loop protection on the flyback converter is a safe restart on the TEA1753T
- IC OverTemperature Protection (OTP)
- Low and adjustable OverCurrent Protection (OCP) trip level for both converters
- General purpose input for latched protection, e.g. to be used for system OverTemperature Protection (OTP)

3. Applications

- The device can be used in all applications that require an efficient and cost-effective power supply solution for up to 250 W. Notebook adapters in particular can benefit from the high level of integration

4. Ordering information

Table 1. Ordering information

Type number	Package		
	Name	Description	Version
TEA1753T	SO16	plastic small outline package; 16 leads; body width 3.9 mm	SOT109-1

5. Block diagram

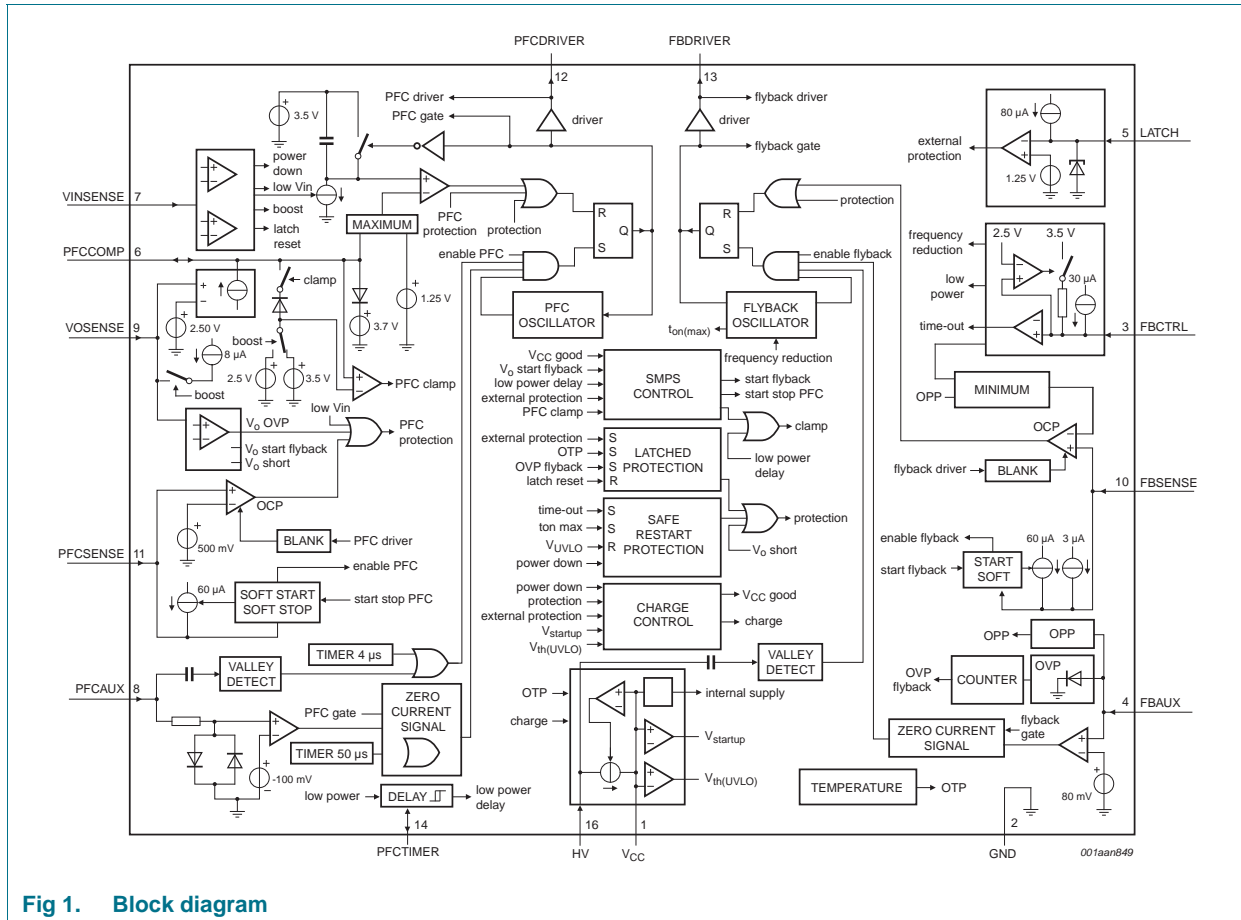

Fig 1. Block diagram

6. Pinning information

6.1 Pinning

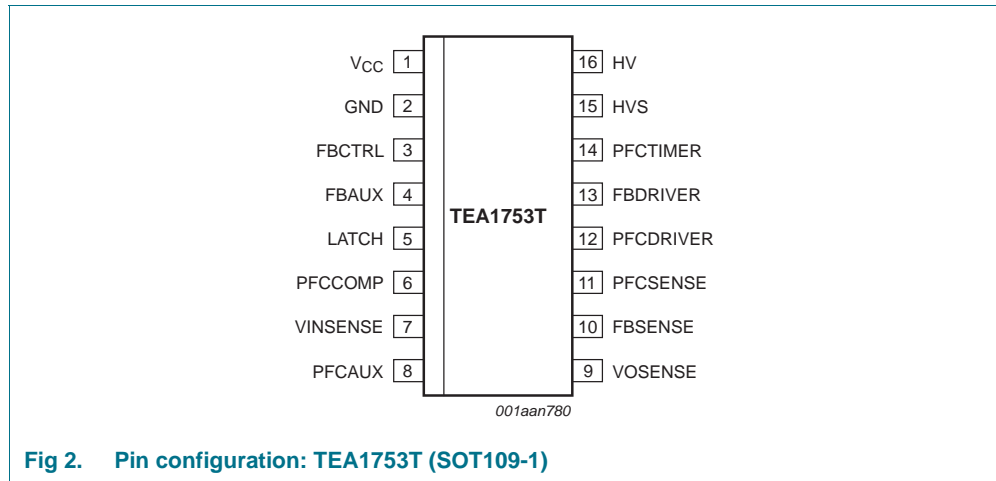

Fig 2. Pin configuration: TEA1753T (SOT109-1)

6.2 Pin description

Table 2. Pin description

Symbol	Pin	Description
V _{CC}	1	supply voltage
GND	2	ground
FBCTRL	3	control input for flyback
FBAUX	4	input from auxiliary winding for demagnetization timing and overvoltage protection for flyback
LATCH	5	general purpose protection input
PFCCOMP	6	frequency compensation pin for PFC
VINSENSE	7	sense input for mains voltage
PFCAUX	8	input from auxiliary winding for demagnetization timing for PFC
VOSENSE	9	sense input for PFC output voltage
FBSENSE	10	programmable current sense input for flyback
PFCSENSE	11	programmable current sense input for PFC
PFCDRIVER	12	gate driver output for PFC
FBDRIVER	13	gate driver output for flyback
PFCTIMER	14	delay timer pin for PFC on/off control
HVS	15	high voltage safety spacer, not connected
HV	16	high voltage start-up and valley sensing of flyback part

7. Functional description

7.1 General control

The TEA1753T contains a controller for a power factor correction circuit as well as a controller for a flyback circuit. A typical configuration is shown in [Figure 3](#).

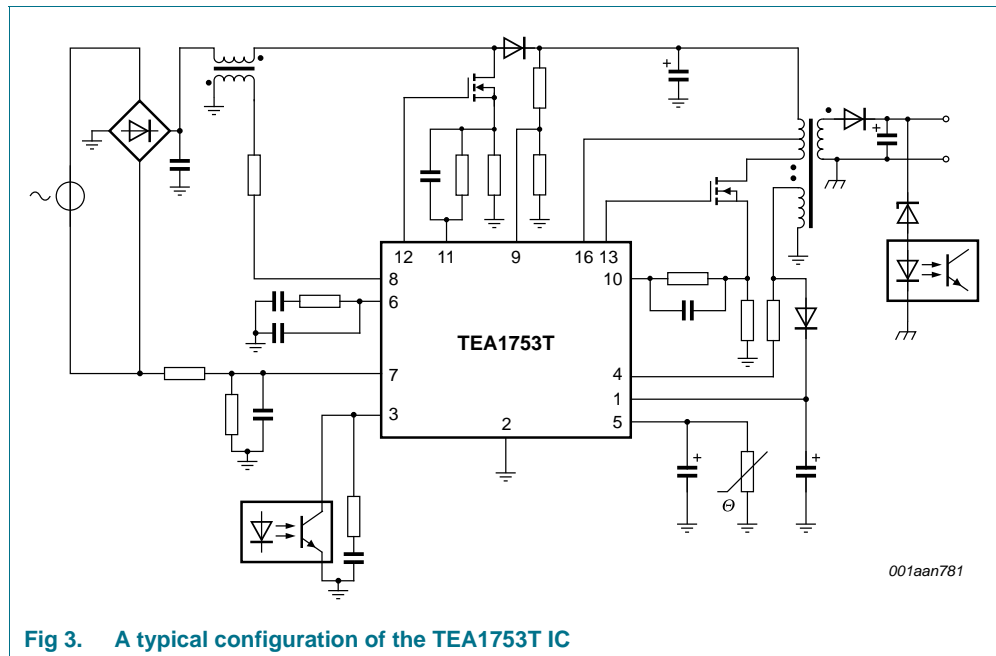

Fig 3. A typical configuration of the TEA1753T IC

7.1.1 Start-up and UnderVoltage LockOut (UVLO)

Initially the capacitor on the V_{CC} pin is charged from the high voltage mains via the HV pin.

As long as V_{CC} is below V_{trip} , the charge current is low. This protects the IC in case the V_{CC} pin is shorted to ground. For a short start-up time the charge current above V_{trip} is increased until V_{CC} reaches $V_{th(UVLO)}$. If V_{CC} is between $V_{th(UVLO)}$ and $V_{startup}$, the charge current is low again, ensuring a low duty cycle during fault conditions.

The control logic activates the internal circuitry and switches off the HV charge current when the voltage on pin V_{CC} passes the $V_{startup}$ level. First, the LATCH pin current source is activated and the soft start capacitors on the PFCSENSE and FBSENSE pins are charged. Also the clamp circuit on the PFCCOMP pin is activated. When the LATCH pin voltage exceeds the $V_{en(LATCH)}$ voltage, the PFCCOMP pin voltage reaches the $V_{en(PFCCOMP)}$ voltage and the soft start capacitor on the PFCSENSE pin is charged, the PFC circuit is activated. Also the flyback converter is activated (providing the soft start capacitor on the FBSENSE pin is charged). The output voltage of the flyback converter is then regulated to its nominal output voltage. The IC supply is taken over by the auxiliary winding of the flyback converter. See [Figure 4](#).

If during start-up the LATCH pin does not reach the $V_{en(LATCH)}$ level before V_{CC} reaches $V_{th(UVLO)}$, the LATCH pin output is deactivated and the charge current is switched on again.

As soon as the flyback converter is started, the voltage on the FBCTRL pin is monitored. If the output voltage of the flyback converter does not reach its intended regulation level within a predefined time, the voltage on the FBCTRL pin reaches the $V_{to(FBCTRL)}$ level, an error is assumed and a safe restart is initiated.

When one of the protection functions is activated, both converters stop switching and the V_{CC} voltage drops to $V_{th(UVLO)}$. A latched protection recharges the capacitor C_{VCC} via the HV pin, but does not restart the converters. For a safe restart protection, the capacitor is recharged via the HV pin and the device restarts (see block diagram, [Figure 1](#)).

In the event of an overvoltage protection of the PFC circuit, $V_{VOSENSE} > V_{OVP(VOSENSE)}$, only the PFC controller stops switching until the VOSENSE pin voltage drops below $V_{OVP(VOSENSE)}$ again. Also, if a mains undervoltage is detected $V_{VINSENSE} < V_{stop(VINSENSE)}$, only the PFC controller stops switching until $V_{VINSENSE} > V_{start(VINSENSE)}$ again.

When the voltage on pin V_{CC} drops below the undervoltage lockout level, both controllers stop switching and reenter the safe restart mode. In the safe restart mode the driver outputs are disabled and the V_{CC} pin voltage is recharged via the HV pin.

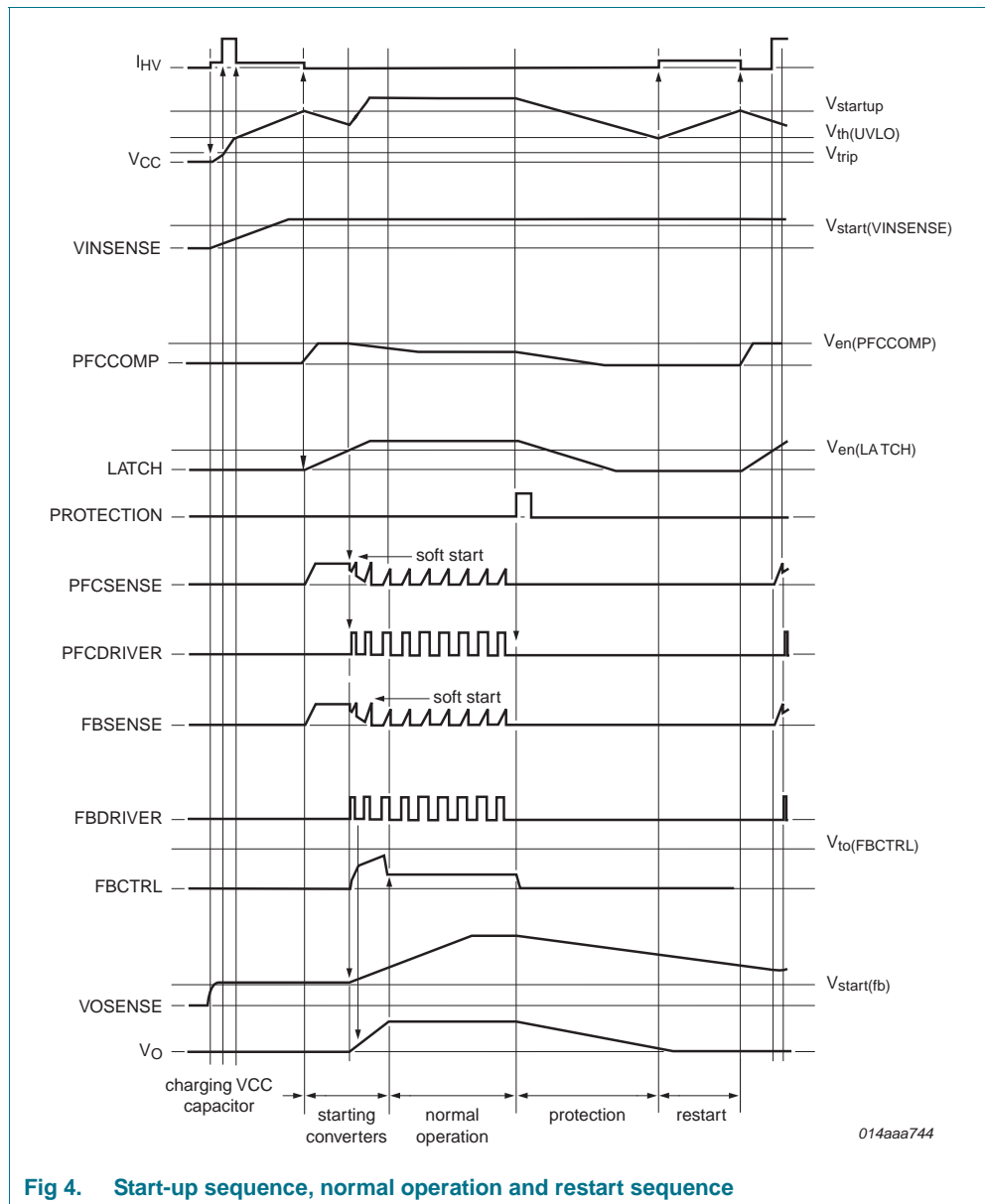

Fig 4. Start-up sequence, normal operation and restart sequence

7.1.2 Power down

For very low standby power applications the power-down mode can be activated by pulling the VINSENSE pin below the $V_{th(powerdown)}$ level. The TEA1753T will stop switching and the safe restart protection will be activated. Because the high voltage start-up current source is also disabled during power-down, the TEA1753T will not restart until the VINSENSE pin voltage is raised again. During power down all internal circuitry is disabled except for a voltage detection circuit on the VINSENSE pin. This circuit is supplied by the HV pin and will draw 16 μA from the HV pin for biasing.

7.1.3 Supply management

All internal reference voltages are derived from a temperature compensated and trimmed on-chip band gap circuit. Internal reference currents are derived from a temperature compensated and trimmed on-chip current reference circuit.

7.1.4 Latch input

Pin LATCH is a general purpose input pin, which is used to switch off both converters. The pin sources a current $I_{O(LATCH)}$ of 80 μ A. Switching off both converters is stopped as soon as the voltage on this pin drops below 1.25 V.

At initial start-up the switching is inhibited until the capacitor on the LATCH pin is charged above 1.35 V. No internal filtering is done on this pin. An internal zener clamp of 2.9 V protects this pin from excessive voltages.

7.1.5 Fast latch reset

In a typical application the mains can be interrupted briefly to reset the latched protection. The PFC bus capacitor, C_{bus} , does not have to discharge for this latched protection to reset.

The PFC bus capacitor, C_{bus} , must discharge to allow the V_{CC} to drop to the reset level. When the latched protection is set, the clamping circuit of the VINSENSE circuit is disabled. (see also [Section 7.2.10](#)) As soon as the VINSENSE voltage drops below 750 mV and after that is raised to 870 mV, the latched protection is reset.

The latched protection is also reset by removing both the voltage on pin V_{CC} and on pin HV.

7.1.6 Overtemperature protection

An accurate internal temperature protection is provided in the circuit. When the junction temperature exceeds the thermal shut-down temperature, the IC stops switching. As long as OTP is active, the capacitor C_{VCC} is not recharged from the HV mains. The OTP circuit is supplied from the HV pin if the V_{CC} supply voltage is not sufficient.

OTP is a latched protection. It can be reset by removing both the voltage on pin V_{CC} and on pin HV or by the fast latch reset function. (See [Section 7.1.5](#))

7.2 Power factor correction circuit

The power factor correction circuit operates in quasi-resonant or discontinuous conduction mode with valley switching. The next primary stroke is only started when the previous secondary stroke has ended and the voltage across the PFC MOSFET has reached a minimum value. The voltage on the PFCAUX pin is used to detect transformer demagnetization and the minimum voltage across the external PFC MOSFET switch.

7.2.1 t_{on} control

The power factor correction circuit is operated in t_{on} control. The resulting mains harmonic reduction of a typical application is well within the class-D requirements.

7.2.2 Valley switching and demagnetization (PFC_AUX pin)

The PFC MOSFET is switched on after the transformer is demagnetized. Internal circuitry connected to the PFC_AUX pin detects the end of the secondary stroke. It also detects the voltage across the PFC MOSFET. The next stroke is started if the voltage across the PFC MOSFET is at its minimum in order to reduce switching losses and ElectroMagnetic Interference (EMI) (valley switching).

If no demagnetization signal is detected on the PFC_AUX pin, the controller generates a Zero Current Signal (ZCS), 50 μ s after the last PFC_GATE signal.

If no valley signal is detected on the PFC_AUX pin, the controller generates a valley signal 4 μ s after demagnetization is detected.

To protect the internal circuitry during lightning events, for example, it is advisable to add a 5 k Ω series resistor to this pin. To prevent incorrect switching due to external disturbance, the resistor should be placed close to the IC on the printed-circuit board.

7.2.3 Frequency limitation

To optimize the transformer and minimize switching losses, the switching frequency is limited to $f_{sw(PFC)max}$. If the frequency for quasi-resonant operation is above the $f_{sw(PFC)max}$ limit, the system switches over to discontinuous conduction mode. Also here, the PFC MOSFET is only switched on at a minimum voltage across the switch (valley switching).

7.2.4 Mains voltage compensation (VINSENSE pin)

The mathematical equation for the transfer function of a power factor corrector contains the square of the mains input voltage. In a typical application this results in a low bandwidth for low mains input voltages, while at high mains input voltages the Mains Harmonic Reduction (MHR) requirements may be hard to meet.

To compensate for the mains input voltage influence, the TEA1753T contains a correction circuit. Via the VINSENSE pin the average input voltage is measured and the information is fed to an internal compensation circuit. With this compensation it is possible to keep the regulation loop bandwidth constant over the full mains input range, yielding a fast transient response on load steps, while still complying with class-D MHR requirements.

In a typical application, the bandwidth of the regulation loop is set by a resistor and two capacitors on the PFCCOMP pin.

7.2.5 Soft start-up (pin PFCSENSE)

To prevent audible transformer noise at start-up or during hiccup, the transformer peak current, I_{DM} , is increased slowly by the soft start function. This can be achieved by inserting R_{SS1} and C_{SS1} between pin PFCSENSE and current sense resistor R_{SENSE1} . An internal current source charges the capacitor to:

$$V_{PFCSENSE} = I_{start(soft)PFC} \times R_{SS1} \quad (1)$$

The voltage is limited to $V_{start(soft)PFC}$.

The start level and the time constant of the increasing primary current level can be adjusted externally by changing the values of R_{SS1} and C_{SS1} .

$$\tau_{softstart} = 3 \times R_{SS1} \times C_{SS1} \quad (2)$$

The charging current $I_{\text{start(soft)PFC}}$ flows as long as the voltage on pin PFCSENSE is below 0.5 V. If the voltage on pin PFCSENSE exceeds 0.5 V, the soft start current source starts limiting current $I_{\text{start(soft)PFC}}$. As soon as the PFC starts switching, the $I_{\text{start(soft)PFC}}$ current source is switched off; see [Figure 5](#).

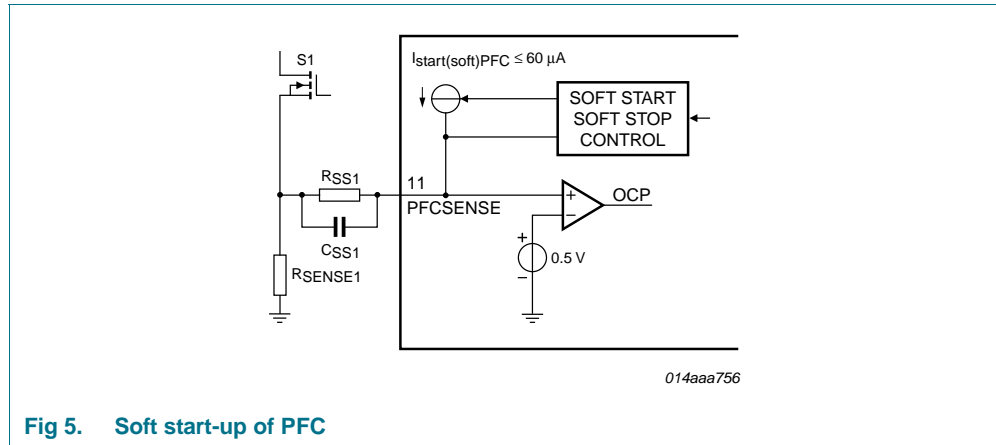

Fig 5. Soft start-up of PFC

7.2.6 Low power mode

When the output power of the flyback converter (see [Section 7.3](#)) is low, the flyback converter switches over to frequency reduction mode. When the maximum switching frequency of the flyback drops below 48 kHz, the power factor correction circuit is switched off to maintain high efficiency. The switch-off can be delayed by connecting a capacitor to the PFCTIMER pin. (see [Section 7.2.7](#)).

During low power mode operation, the PFCCOMP pin is clamped to a minimum voltage of 3.5 V or 2.5 V, dependent on the voltage on VINSENSE pin, and a maximum voltage of 3.7 V. The lower clamp voltage limits the maximum power that is delivered when the PFC is switched on again. The upper clamp voltage ensures that the PFC can return to its normal regulation point in a limited amount of time when returning from low power mode.

As soon as the maximum switching frequency of the flyback converter exceeds 86 kHz, the power factor correction circuit restores normal operation.

7.2.7 PFC off delay (pin PFCTIMER)

When the maximum switching frequency of the flyback controller drops below 48 kHz, the PFC is switched off. To prevent the PFC from switching off due to a fast changing load at the flyback output, the PFC switch-off can be delayed by connecting a capacitor to the PFCTIMER pin.

When the flyback controller part detects a low power, it enters frequency reduction mode and the IC outputs a 5 μA current to the PFCTIMER pin. When the voltage on the PFCTIMER pin reaches 3.75 V, the PFC is switched off by performing a soft stop.

When the flyback controller part leaves the frequency reduction mode, a switch discharges the PFCTIMER pin capacitor. When the voltage on the PCTIMER pin drops below 1.25 V, the PFC is switched on (see [Figure 6](#)).

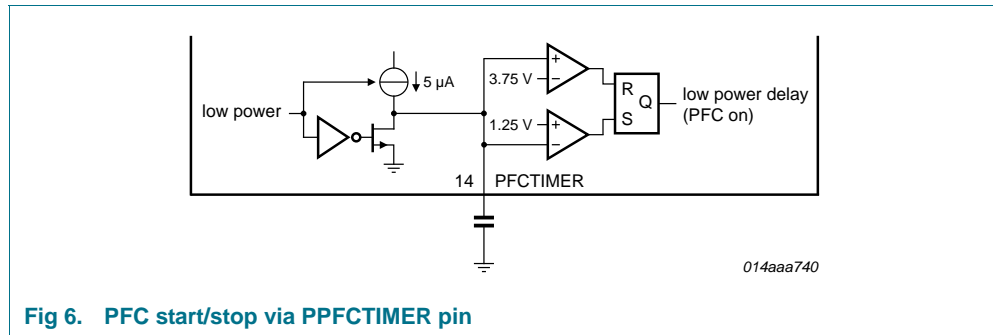

Fig 6. PFC start/stop via PFCTIMER pin

7.2.8 Dual boost PFC

The PFC output voltage is modulated by the mains input voltage. The mains input voltage is measured via the VINSENSE pin. The current is sourced from the VOSENSE pin if the voltage on the VINSENSE pin drops below 2.2 V. To ensure the stable switch-over, a 200 mV transition region is inserted around the 2.2 V, see [Figure 7](#).

For low VINSENSE input voltages, the output current is 8 µA. This output current, in combination with the resistors on the VOSENSE pin, sets the lower PFC output voltage level at low mains voltages. At high mains input voltages the current is switched to zero. The PFC output voltage will then be at its maximum. As this current is zero in this situation, it does not effect the accuracy of the PFC output voltage.

For proper switch-off behavior, the VOSENSE current is switched to its maximum value of 8 µA, as soon as the voltage on pin VOSENSE drops below 2.1 V.

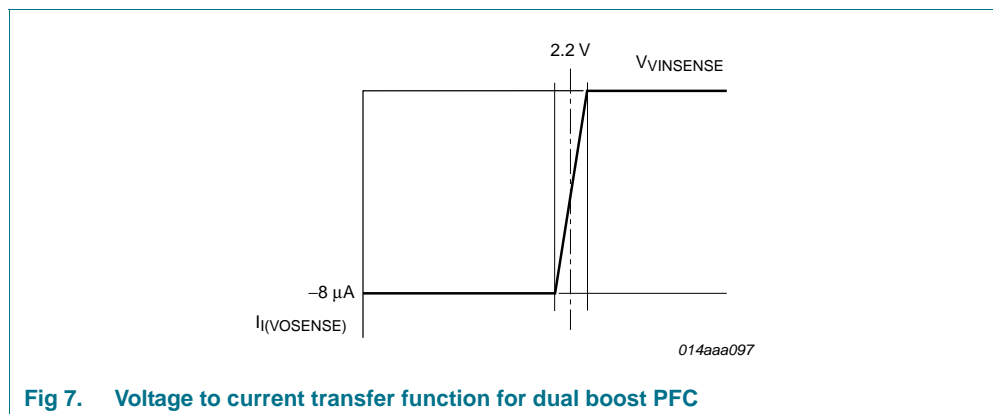

Fig 7. Voltage to current transfer function for dual boost PFC

7.2.9 Overcurrent protection (PFCSENSE pin)

The maximum peak current is limited cycle-by-cycle by sensing the voltage across an external sense resistor, R_{SENSE1} , on the source of the external MOSFET. The voltage is measured via the PFCSENSE pin.

7.2.10 Mains undervoltage lockout / brownout protection (VINSENSE pin)

To prevent the PFC from operating at very low mains input voltages, the voltage on the VINSENSE pin is sensed continuously. As soon as the voltage on this pin drops below the $V_{stop(VINSENSE)}$ level, switching of the PFC is stopped.

7.2.11 Overvoltage protection (VOSENSE pin)

To prevent output overvoltage during load steps and mains transients an overvoltage protection circuit is built in.

As soon as the voltage on the VOSENSE pin exceeds the $V_{OVP(VOSENSE)}$ level, switching of the power factor correction circuit is inhibited. Switching of the PFC recommences as soon as the VOSENSE pin voltage drops below the $V_{OVP(VOSENSE)}$ level again.

When the resistor between pin VOSENSE and ground is open, the overvoltage protection is also triggered.

7.2.12 PFC open-loop protection (VOSENSE pin)

The power factor correction circuit does not start switching until the voltage on the VOSENSE pin is above the $V_{th(ol)(VOSENSE)}$ level. This protects the circuit from open-loop and VOSENSE short situations.

7.2.13 Driver (pin PFCDRIVER)

The driver circuit to the gate of the power MOSFET has a current sourcing capability of -500 mA and a current sink capability of 1.2 A. This permits fast turn-on and turn-off of the power MOSFET for efficient operation.

7.3 Flyback controller

The TEA1753T includes a controller for a flyback converter. The flyback converter operates in quasi-resonant or discontinuous conduction mode with valley switching. The auxiliary winding of the flyback transformer provides demagnetization detection and powers the IC after start-up.

7.3.1 Multimode operation

The TEA1753T flyback controller can operate in several modes; see [Figure 8](#).

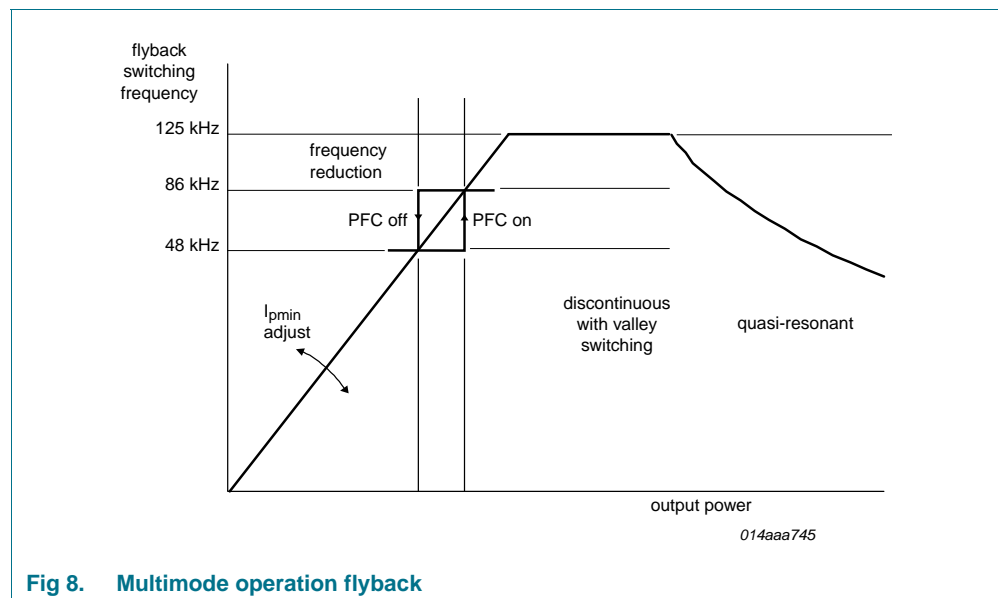

Fig 8. Multimode operation flyback

At high output power the converter switches to quasi-resonant mode. The next converter stroke is started after demagnetization of the transformer current. In quasi-resonant mode switching losses are minimized as the converter only switches on when the voltage across the external MOSFET is at its minimum (valley switching, see also [Section 7.3.2](#)).

To prevent high frequency operation at lower loads, the quasi-resonant operation changes to discontinuous mode operation with valley skipping in which the switching frequency is limited for EMI to $f_{sw(fb)max}$ (125 kHz). Again, the external MOSFET is only switched on when the voltage across the MOSFET is at its minimum.

At very low power and standby levels the frequency is controlled down by a Voltage Controlled Oscillator (VCO). The minimum frequency can be reduced to zero. During frequency reduction mode, the primary peak current is kept at an adjustable minimal level to maintain a high efficiency. As the primary peak current is low in frequency reduction operation, no audible noise is noticeable at switching frequencies in the audible range. Valley switching is also active in this mode.

In frequency reduction mode the PFC controller is switched off and the flyback maximum frequency changes linearly with the control voltage on the FBCTRL pin (see [Figure 9](#)). For stable on and off switching of the PFC, hysteresis has been added. At no load operation the switching frequency can be reduced to (almost) zero.

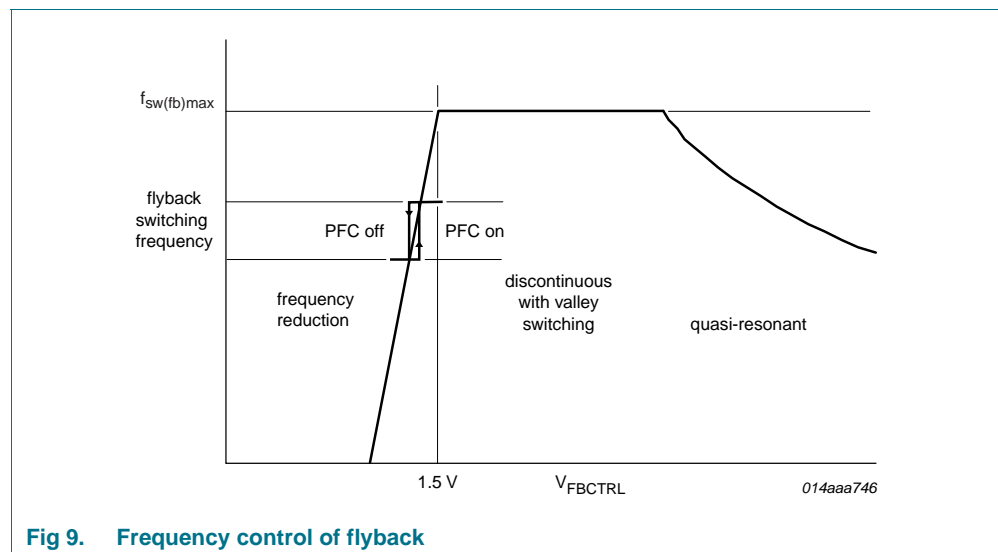

Fig 9. Frequency control of flyback

7.3.2 Valley switching (HV pin)

Refer to [Figure 10](#). A new cycle starts when the external MOSFET is activated. After the on-time (determined by the FBSENSE voltage and the FBCTRL voltage), the MOSFET is switched off and the secondary stroke starts. After the secondary stroke, the drain voltage shows an oscillation with a frequency of approximately:

$$f = \frac{1}{[2 \times \pi \times \sqrt{(L_p \times C_d)}]} \quad (3)$$

where L_p is the primary self-inductance of the flyback transformer and C_d is the capacitance on the drain node.

As soon as the internal oscillator voltage is high again and the secondary stroke has ended, the circuit waits for the lowest drain voltage before starting a new primary stroke. [Figure 10](#) shows the drain voltage, valley signal, secondary stroke signal and the internal oscillator signal.

Valley switching allows high frequency operation as capacitive switching losses are reduced, see [Equation 4](#). High frequency operation makes small and cost-effective magnetics possible.

$$P = \frac{1}{2} \times C_d \times V^2 \times f \quad (4)$$

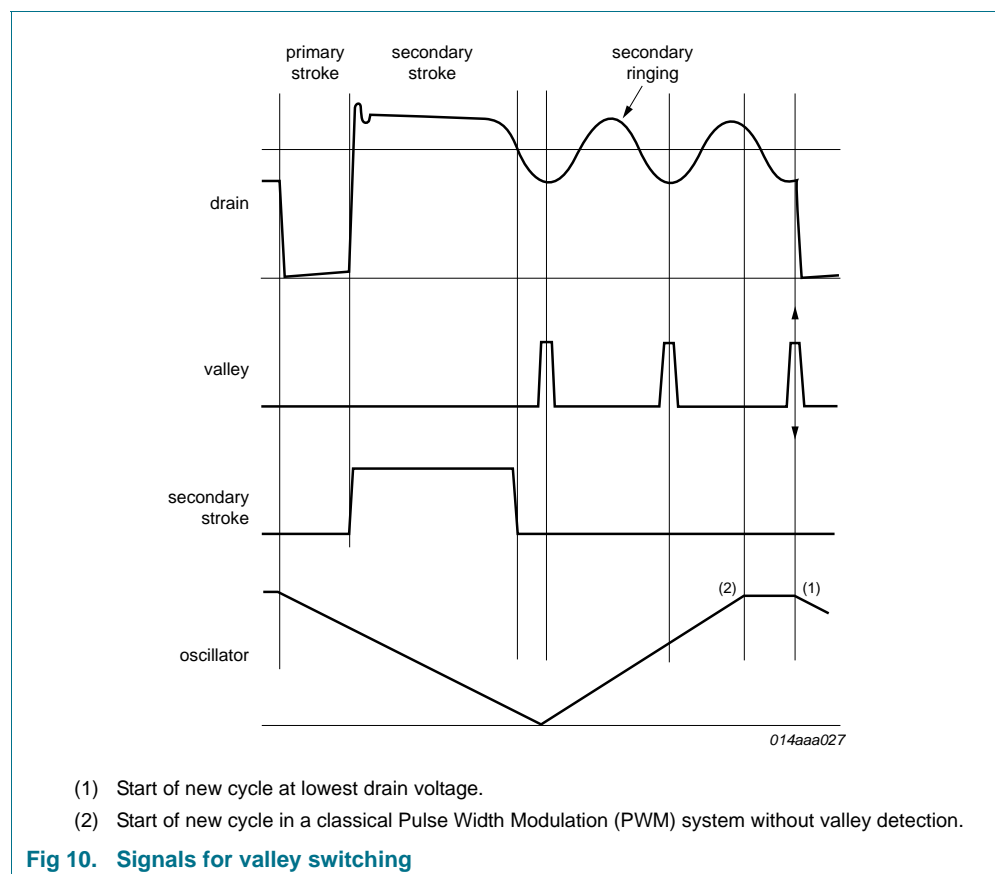

7.3.3 Current mode control (FBSENSE pin)

Current mode control is used for the flyback converter for its good line regulation.

The primary current is sensed by the FBSENSE pin across an external resistor and compared with an internal control voltage. The internal control voltage is proportional to the FBCTRL pin voltage, see [Figure 11](#).

The FBSENSE pins outputs a current of 3 μ A. This current runs through the resistors from the FBSENSE pin to the sense resistor and creates an offset voltage. The minimum peak current of the flyback is adjusted using this offset voltage. Adjusting the minimum peak current level, will change the frequency reduction slope. (see [Figure 8](#))

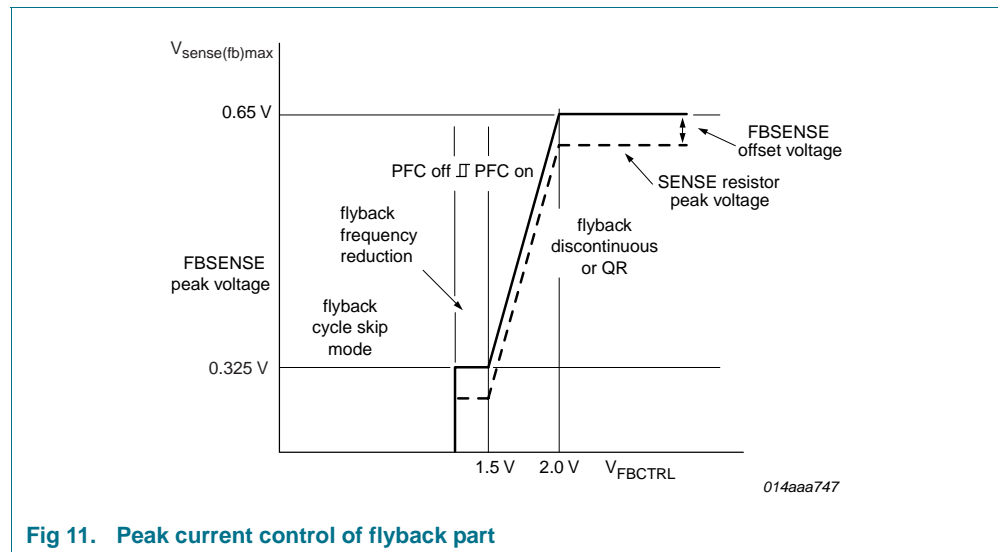

Fig 11. Peak current control of flyback part

The driver output is latched in the logic, preventing multiple switch-on.

7.3.4 Demagnetization (FBAUX pin)

The system is always in quasi-resonant or discontinuous conduction mode. The internal oscillator does not start a new primary stroke until the previous secondary stroke has ended.

Demagnetization features a cycle-by-cycle output short circuit protection by immediately lowering the frequency (longer off-time), thereby reducing the power level.

Demagnetization recognition is suppressed during the first $t_{sup}(xfmr_ring)$ time of 2 μ s. This suppression may be necessary at low output voltages and at start-up and in applications where the transformer has a large leakage inductance.

If pin FBAUX is open circuit or not connected, a fault condition is assumed and the converter stops operating immediately. Operation restarts as soon as the fault condition is removed.

7.3.5 Flyback control / time-out (FBCTRL pin)

The pin FBCTRL is connected to an internal voltage source of 3.5 V via an internal resistor of 3 k Ω . As soon as the voltage on this pin exceeds 2.5 V, the connection is disabled and the pin is biased with a small current. When the voltage on this pin exceeds 4.5 V, a fault is assumed, switching is inhibited and a restart is made.

When a small capacitor is connected to this pin, a time-out function is created to protect against an open control loop situation. (see [Figure 12](#) and [Figure 13](#)) The time-out function is disabled by connecting a resistor (100 k Ω) to ground on the FBCTRL pin.

If the pin is shorted to ground, switching of the flyback controller is inhibited.

During normal operating conditions, when the converter is regulating the output voltage, the voltage on the FBCTRL pin is between 1.4 V and 2.0 V from minimum to maximum output power.

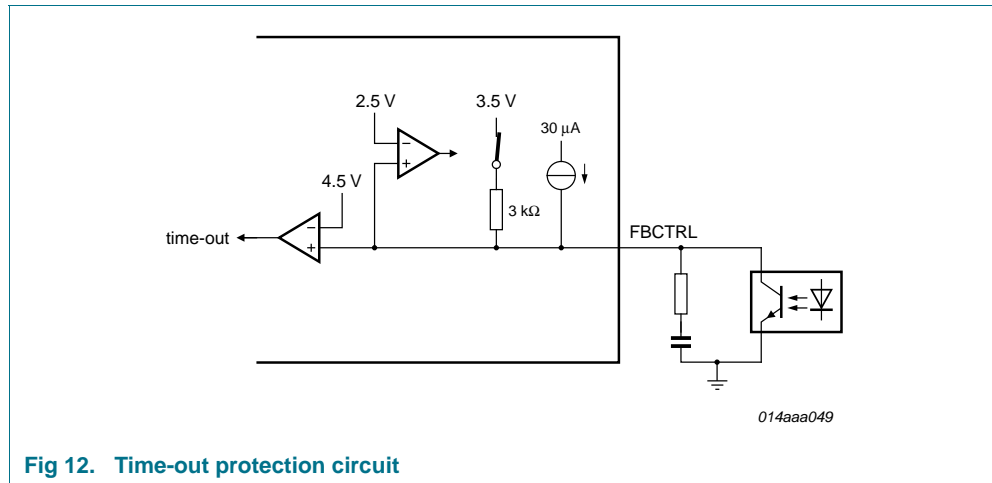

Fig 12. Time-out protection circuit

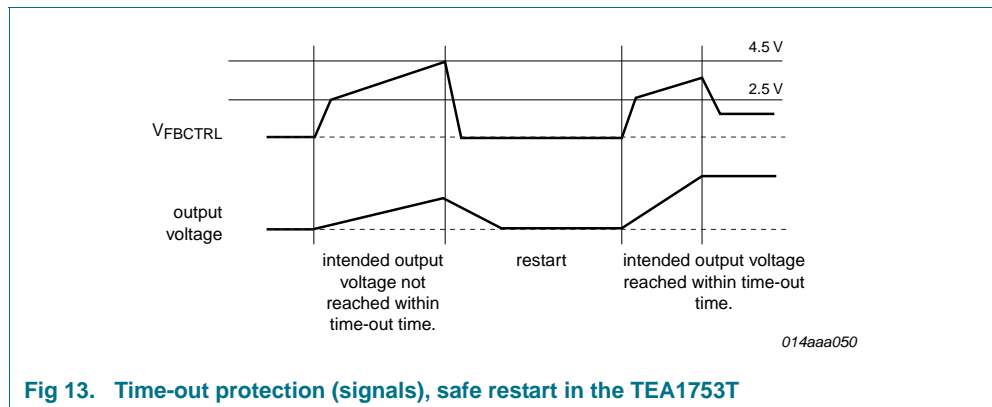

Fig 13. Time-out protection (signals), safe restart in the TEA1753T

7.3.6 Soft start-up (pin FBSENSE)

To prevent audible transformer noise during start-up, the transformer peak current, I_{DM} is slowly increased by the soft start function. This can be achieved by inserting a resistor and a capacitor between pin 10 (FBSENSE) and the current sense resistor.

An internal current source charges the capacitor to:

$$V = I_{start(soft)fb} \times R_{SS2} \tag{5}$$

with a maximum of approximately 0.63 V.

The start level and the time constant of the increasing primary current level can be adjusted externally by changing the values of R_{SS2} and C_{SS2} .

$$\tau_{softstart} = 3 \times R_{SS2} \times C_{SS2} \tag{6}$$

The soft start current $I_{start(soft)fb}$ is switched on as soon as V_{CC} reaches $V_{startup}$. When the voltage on pin FBSENSE has reached 0.63 V the flyback converter starts switching.

The charging current $I_{start(soft)(FB)}$ flows as long as the voltage on pin FBSENSE is below approximately 0.63 V. If the voltage on pin FBSENSE exceeds 0.63 V, the soft start current source starts limiting the current. After the flyback converter has started, the soft start current source is switched off.

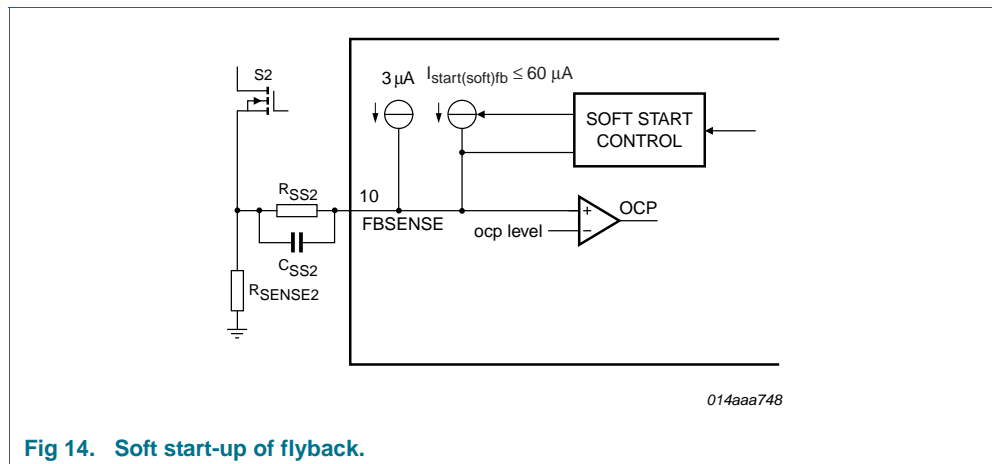

Fig 14. Soft start-up of flyback.

7.3.7 Maximum on-time

The flyback controller limits the ‘on-time’ of the external MOSFET to 40 μs. When the ‘on-time’ is longer than 40 μs, the IC stops switching and enters the safe restart mode.

7.3.8 Overvoltage protection (FBAUX pin)

An output overvoltage protection is implemented in the GreenChip III series. In the TEA1753T this works by sensing the auxiliary voltage via the current flowing into pin FBAUX during the secondary stroke. The auxiliary winding voltage is a well-defined replica of the output voltage. Voltage spikes are averaged by an internal filter.

If the output voltage exceeds the OVP trip level, an internal counter starts counting subsequent OVP events. The counter has been added to prevent incorrect OVP detection which might occur during ESD or lightning events. If the output voltage exceeds the OVP trip level a few times and not again in a subsequent cycle, the internal counter counts down at twice the speed it uses when counting up. However, after 8 cycles of subsequent OVP events are detected, the IC assumes a true OVP and the OVP circuit switches the power MOSFET off. As the protection is latched, the converter only restarts after the internal latch is reset. In a typical application the mains should be interrupted to reset the internal latch.

The output voltage $V_{o(OVP)}$ at which the OVP function trips, can be set by the demagnetization resistor, R_{FBAUX} :

$$V_{o(OVP)} = \frac{N_s}{N_{aux}} (I_{ovp(FBAUX)} \times R_{FBAUX} + V_{clamp(FBAUX)}) \tag{7}$$

where N_s is the number of secondary turns and N_{aux} is the number of auxiliary turns of the transformer. Current $I_{ovp(FBAUX)}$ is internally trimmed.

The value of R_{FBAUX} can be adjusted to the turns ratio of the transformer, thus making an accurate OVP detection possible.

7.3.9 Overcurrent protection (FBSENSE pin)

The primary peak current in the transformer is measured accurately cycle-by-cycle using the external sense resistor R_{sense2} . The OCP circuit limits the voltage on pin FBSENSE to an internal level (see also [Section 7.3.3](#)). The OCP detection is suppressed during the leading edge blanking period, t_{leb} , to prevent false triggering caused by switch-on spikes.

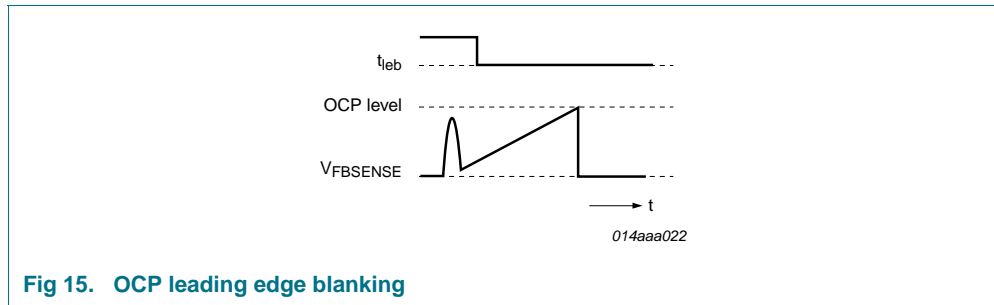

Fig 15. OCP leading edge blanking

7.3.10 Overpower protection

During the primary stroke of the flyback converter the input voltage of the flyback converter is measured by sensing the current that is drawn from the pin FBAUX.

The current information is used to adjust the peak drain current of the flyback converter, which is measured via pin FBSENSE. The internal compensation is such, that a maximum output power can be realized that is almost independent of the input voltage.

The OPP curve is given in [Figure 16](#).

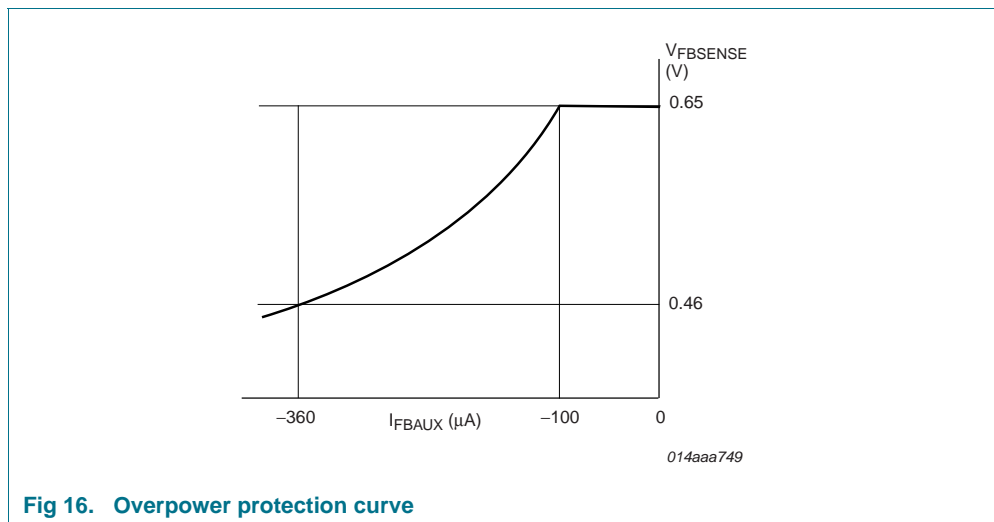

Fig 16. Overpower protection curve

7.3.11 Driver (pin FBDRIVER)

The driver circuit to the gate of the external power MOSFET has a current sourcing capability of -500 mA and a current sink capability of 1.2 A. This permits fast turn-on and turn-off of the power MOSFET for efficient operation.

8. Limiting values

Table 3. Limiting values

In accordance with the Absolute Maximum Rating System (IEC 60134).

Symbol	Parameter	Conditions	Min	Max	Unit
Voltages					
V _{CC}	supply voltage		-0.4	+38	V
V _{LATCH}	voltage on pin LATCH	current limited	-0.4	+5	V
V _{FBCTRL}	voltage on pin FBCTRL		-0.4	+5	V
V _{PFCCOMP}	voltage on pin PFCCOMP		-0.4	+5	V
V _{VINSENSE}	voltage on pin VINSENSE		-0.4	+5	V
V _{VOSENSE}	voltage on pin VOSENSE		-0.4	+5	V
V _{PFCAUX}	voltage on pin PFCAUX		-25	+25	V
V _{FBSNSE}	voltage on pin FBSNSE	current limited	-0.4	+5	V
V _{PFCSNSE}	voltage on pin PFCSNSE	current limited	-0.4	+5	V
V _{PFCTIMER}	voltage on pin PFCTIMER		-0.4	+5	V
V _{HV}	voltage on pin HV		-0.4	+650	V
Currents					
I _{FBCTRL}	current on pin FBCTRL		-3	0	mA
I _{FBAUX}	current on pin FBAUX		-1	+1	mA
I _{PFCSNSE}	current on pin PFCSNSE		-1	+10	mA
I _{FBSNSE}	current on pin FBSNSE		-1	+10	mA
I _{FBDRIVER}	current on pin FBDRIVER	duty cycle < 10 %	-0.8	+2	A
I _{PFCDRIVER}	current on pin PFCDRIVER	duty cycle < 10 %	-0.8	+2	A
I _{HV}	current on pin HV		-	5	mA
General					
P _{tot}	total power dissipation	T _{amb} < 75 °C	-	0.6	W
T _{stg}	storage temperature		-55	+150	°C
T _j	junction temperature		-20	+150	°C
ESD					
V _{ESD}	electrostatic discharge voltage	class 1			
		human body model			
		pins 1 to 13	[1] -	2000	V
		pin 16 (HV)	[1] -	1500	V
		machine model	[2] -	200	V
		charged device model	-	500	V

[1] Equivalent to discharging a 100 pF capacitor through a 1.5 kΩ series resistor.

[2] Equivalent to discharging a 200 pF capacitor through a 0.75 μH coil and a 10 Ω resistor.

9. Thermal characteristics

Table 4. Thermal characteristics

Symbol	Parameter	Conditions	Typ	Unit
$R_{th(j-a)}$	thermal resistance from junction to ambient	in free air; JEDEC test board	124	K/W
$R_{th(j-c)}$	thermal resistance from junction to case	in free air; JEDEC test board	37	K/W

10. Characteristics

Table 5. Characteristics

$T_{amb} = 25\text{ }^{\circ}\text{C}$; $V_{CC} = 20\text{ V}$; all voltages are measured with respect to ground (pin 2); currents are positive when flowing into the IC; unless otherwise specified.

Symbol	Parameter	Conditions	Min	Typ	Max	Unit
Start-up current source (pin HV)						
I_{HV}	current on pin HV	$V_{HV} > 80\text{ V}$				
		$V_{CC} < V_{trip}$; $V_{th(UVLO)} < V_{CC} < V_{startup}$	-	1.0	-	mA
		$V_{trip} < V_{CC} < V_{th(UVLO)}$	-	5.4	-	mA
		with auxiliary supply	8	20	40	μA
		in power down mode		16		μA
V_{BR}	breakdown voltage		650	-	-	V
Supply voltage management (pin V_{CC})						
V_{trip}	trip voltage		0.55	0.65	0.75	V
$V_{startup}$	start-up voltage		21	22	23	V
$V_{th(UVLO)}$	undervoltage lockout threshold voltage		14	15	16	V
$V_{start(hys)}$	hysteresis of start voltage	during start-up phase	-	300	-	mV
V_{hys}	hysteresis voltage	$V_{startup} - V_{th(UVLO)}$	6.3	7	7.7	V
$I_{ch(low)}$	low charging current	$V_{HV} > 80\text{ V}$; $V_{CC} < V_{trip}$ or $V_{th(UVLO)} < V_{CC} < V_{startup}$	-1.2	-1.0	-0.8	mA
$I_{ch(high)}$	high charging current	$V_{HV} > 80\text{ V}$; $V_{trip} < V_{CC} < V_{th(UVLO)}$	-4.6	-5.4	-6.3	mA
$I_{CC(oper)}$	operating supply current	no load on pin FBDRIVER and PFCDRIVER	2.25	3	3.75	mA
Input Voltage Sensing PFC (pin VINSENSE)						
$V_{stop(VINSENSE)}$	stop voltage on pin VINSENSE		0.85	0.88	0.91	V
$V_{start(VINSENSE)}$	start voltage on pin VINSENSE		1.11	1.15	1.19	V
$V_{mvc(VINSENSE)max}$	maximum mains voltage compensation voltage on pin VINSENSE		4.0	-	-	V
V_{flr}	fast latch reset voltage	active after $V_{th(UVLO)}$ is detected	-	0.75	-	V
$V_{flr(hys)}$	hysteresis of fast latch reset voltage		-	0.12	-	V
$I_{I(VINSENSE)}$	input current on pin VINSENSE	$V_{VINSENSE} > V_{stop(VINSENSE)}$ after $V_{start(VINSENSE)}$ is detected	5	33	100	nA

Table 5. Characteristics ...continued

$T_{amb} = 25\text{ }^{\circ}\text{C}$; $V_{CC} = 20\text{ V}$; all voltages are measured with respect to ground (pin 2); currents are positive when flowing into the IC; unless otherwise specified.

Symbol	Parameter	Conditions	Min	Typ	Max	Unit
$V_{bst(dual)}$	dual boost voltage	current switch-over point	-	2.2	-	V
		switch-over region	-	200	-	mV
$V_{th(pd)}$	power-down threshold voltage		-	280	-	mV
$V_{hys(pd)}$	power-down hysteresis voltage		-	200	-	mV
Loop compensation PFC (pin PFCCOMP)						
g_m	transconductance	$V_{VOSENSE}$ to $I_{O(PFCCOMP)}$	60	80	100	$\mu\text{A/V}$
$I_{O(PFCCOMP)}$	output current on pin PFCCOMP	$V_{VOSENSE} = 2.0\text{ V}$	33	39	45	μA
		$V_{VOSENSE} = 3.3\text{ V}$	-45	-39	-33	μA
$V_{en(PFCCOMP)}$	enable voltage on pin PFCCOMP	$V_{INSENSE} \geq V_{bst(dual)}$		3.5		V
		$V_{INSENSE} < V_{bst(dual)}$		2.5		V
$V_{clamp(PFCCOMP)}$	clamp voltage on pin PFCCOMP	Low power mode; PFC off; lower clamp voltage.	[1]			
		$V_{INSENSE} \geq V_{bst(dual)}$	-	3.5	-	V
		$V_{INSENSE} < V_{bst(dual)}$	-	2.5	-	V
		Upper clamp voltage	-	3.7	-	V
$V_{ton(PFCCOMP)zero}$	zero on-time voltage on pin PFCCOMP		3.4	3.5	3.6	V
$V_{ton(PFCCOMP)max}$	maximum on-time voltage on pin PFCCOMP		1.20	1.25	1.30	V
Pulse width modulator PFC						
$t_{on(PFC)}$	PFC on-time	$V_{VINSENSE} = 3.3\text{ V}$; $V_{PFCCOMP} = V_{ton(PFCCOMP)max}$	3.6	4.5	5.0	μs
		$V_{VINSENSE} = 0.9\text{ V}$; $V_{PFCCOMP} = V_{ton(PFCCOMP)max}$	30	40	53	μs
Output voltage sensing PFC (pin VOSENSE)						
$V_{th(ol)(VOSENSE)}$	open-loop threshold voltage on pin VOSENSE		-	1.15	-	V
$V_{reg(VOSENSE)}$	regulation voltage on pin VOSENSE	for $I_{O(PFCCOMP)} = 0$	2.475	2.500	2.525	V
$V_{ovp(VOSENSE)}$	overvoltage protection voltage on pin VOSENSE		2.60	2.63	2.67	V
$I_{bst(dual)}$	dual boost current	$V_{VINSENSE} < V_{bst(dual)}$ or $V_{VOSENSE} < 2.1\text{ V}$	-	-8	-	μA
		$V_{VINSENSE} > V_{bst(dual)}$	-	-30	-	nA
Over current protection PFC (pin PFCSENSE)						
$V_{sense(PFC)max}$	maximum PFC sense voltage	$\Delta V/\Delta t = 50\text{ mV}/\mu\text{s}$	0.49	0.52	0.55	V
		$\Delta V/\Delta t = 200\text{ mV}/\mu\text{s}$	0.51	0.54	0.57	V
$t_{leb(PFC)}$	PFC leading edge blanking time		250	310	370	ns
$I_{prot(PFCSENSE)}$	protection current on pin PFCSENSE		-50	-	-5	nA

Table 5. Characteristics ...continued

$T_{amb} = 25\text{ }^{\circ}\text{C}$; $V_{CC} = 20\text{ V}$; all voltages are measured with respect to ground (pin 2); currents are positive when flowing into the IC; unless otherwise specified.

Symbol	Parameter	Conditions	Min	Typ	Max	Unit	
Soft start PFC (pin PFCSENSE)							
$I_{start(soft)PFC}$	PFC soft start current		-75	-60	-45	μA	
$V_{start(soft)PFC}$	PFC soft start voltage	enabling voltage	0.46	0.50	0.54	V	
$V_{stop(soft)PFC}$	PFC soft stop voltage	disabling voltage	0.42	0.45	0.48	V	
$R_{start(soft)PFC}$	PFC soft start resistance		12	-	-	$\text{k}\Omega$	
Oscillator PFC							
$f_{sw(PFC)max}$	maximum PFC switching frequency		-	250	-	kHz	
$t_{off(PFC)min}$	minimum PFC off-time		0.8	1.1	1.4	μs	
Valley switching PFC (pin PFCAUX)							
$(\Delta V/\Delta t)_{vrec(PFC)}$	PFC valley recognition voltage change with time		-	-	1.7	$\text{V}/\mu\text{s}$	
$t_{vrec(PFC)}$	PFC valley recognition time	$V_{PFCAUX} = 1\text{ V peak-peak}$	2	-	-	300	ns
		demagnetization to $\Delta V/\Delta t = 0$	3	-	-	50	ns
$t_{to(vrec)PFC}$	PFC valley recognition time-out time		3	4	6	μs	
Demagnetization management PFC (pin PFCAUX)							
$V_{th(comp)PFCAUX}$	comparator threshold voltage on pin PFCAUX		-150	-100	-50	mV	
$t_{to(demag)PFC}$	PFC demagnetization time-out time		40	50	60	μs	
$I_{prot(PFCAUX)}$	protection current on pin PFCAUX	$V_{PFCAUX} = 50\text{ mV}$	-75	-	-5	nA	
PFC off delay (pin PFCTIMER)							
$I_{source(PFCTIMER)}$	source current on pin PFCTIMER		-	-5	-	μA	
$I_{sink(PFCTIMER)}$	sink current on pin PFCTIMER,	$V_{PFCTIMER} = 5\text{ V}$	-	3.5	-	mA	
$V_{start(PFCTIMER)}$	start voltage on pin PFCTIMER		-	1.25	-	V	
$V_{stop(PFCTIMER)}$	stop voltage on pin PFCTIMER		-	3.75	-	V	
Driver (pin PFCDRIVER)							
$I_{src(PFCDRIVER)}$	source current on pin PFCDRIVER	$V_{PFCDRIVER} = 2\text{ V}$	-	-0.5	-	A	
$I_{sink(PFCDRIVER)}$	sink current on pin PFCDRIVER	$V_{PFCDRIVER} = 2\text{ V}$	-	0.7	-	A	
		$V_{PFCDRIVER} = 10\text{ V}$	-	1.2	-	A	
$V_{O(PFCDRIVER)max}$	maximum output voltage on pin PFCDRIVER		-	11	12	V	
Over Voltage Protection flyback (pin FBAUX)							
$I_{ovp(FBAUX)}$	overvoltage protection current on pin FBAUX		279	300	321	μA	
$N_{cy(ovp)}$	number of overvoltage protection cycles		6	8	12		

Table 5. Characteristics ...continued

$T_{amb} = 25\text{ }^{\circ}\text{C}$; $V_{CC} = 20\text{ V}$; all voltages are measured with respect to ground (pin 2); currents are positive when flowing into the IC; unless otherwise specified.

Symbol	Parameter	Conditions	Min	Typ	Max	Unit
Demagnetization management flyback (pin FBAUX)						
$V_{th(comp)FBAUX}$	comparator threshold voltage on pin FBAUX		60	80	110	mV
$I_{prot(FBAUX)}$	protection current on pin FBAUX	$V_{FBAUX} = 50\text{ mV}$	-75	-	-5	nA
$V_{clamp(FBAUX)}$	clamp voltage on pin FBAUX	$I_{FBAUX} = -100\text{ }\mu\text{A}$	-0.85	-0.7	-0.55	V
		$I_{FBAUX} = 300\text{ }\mu\text{A}$	0.79	0.94	1.09	V
$t_{sup(xfmr_ring)}$	transformer ringing suppression time		1.5	2	2.5	μs
Pulse width modulator flyback						
$t_{on(fb)min}$	minimum flyback on-time		-	t_{leb}	-	ns
$t_{on(fb)max}$	maximum flyback on-time		32	40	48	μs
Oscillator flyback						
$f_{sw(fb)max}$	maximum flyback switching frequency		100	125	150	kHz
$V_{start(VCO)FBCTRL}$	VCO start voltage on pin FBCTRL		1.3	1.5	1.7	V
$f_{sw(fb)swon(PFC)}$	PFC switch-on flyback switching frequency		-	86	-	kHz
$f_{sw(fb)swoff(PFC)}$	PFC switch-off flyback switching frequency		-	48	-	kHz
$\Delta V_{VCO(FBCTRL)}$	VCO voltage difference on pin FBCTRL		-	-0.2	-	V
Peak current control flyback (pin FBCTRL)						
V_{FBCTRL}	voltage on pin FBCTRL	for maximum flyback peak current	1.85	2.0	2.15	V
$V_{to(FBCTRL)}$	time-out voltage on pin FBCTRL	enable voltage	-	2.5	-	V
		trip voltage	4.2	4.5	4.8	V
$R_{int(FBCTRL)}$	internal resistance on pin FBCTRL		-	3	-	k Ω
$I_{O(FBCTRL)}$	output current on pin FBCTRL	$V_{FBCTRL} = 0\text{ V}$	-1.4	-1.19	-0.93	mA
		$V_{FBCTRL} = 2\text{ V}$	-0.6	-0.5	-0.4	mA
$I_{to(FBCTRL)}$	time-out current on pin FBCTRL	$V_{FBCTRL} = 2.6\text{ V}$	-36	-30	-24	μA
		$V_{FBCTRL} = 4.1\text{ V}$	-34.5	-28.5	-22.5	μA
Valley switching flyback (pin HV)						
$(\Delta V/\Delta t)_{vrec(fb)}$	flyback valley recognition voltage change with time		-75	-	+75	V/ μs
$t_{d(vrec-swon)}$	valley recognition to switch-on delay time		2 -	150	-	ns
Soft start flyback (pin FBSENSE)						
$I_{start(soft)fb}$	flyback soft start current		-75	-60	-45	μA
$V_{start(soft)fb}$	flyback soft start voltage	enable voltage	0.55	0.63	0.70	V
$R_{start(soft)fb}$	flyback soft start resistance		8	-	-	k Ω

Table 5. Characteristics ...continued

$T_{amb} = 25\text{ °C}$; $V_{CC} = 20\text{ V}$; all voltages are measured with respect to ground (pin 2); currents are positive when flowing into the IC; unless otherwise specified.

Symbol	Parameter	Conditions	Min	Typ	Max	Unit
Overcurrent protection flyback (pin FBSENSE)						
$V_{\text{sense(fb)max}}$	maximum flyback sense voltage	$\Delta V/\Delta t = 50\text{ mV}/\mu\text{s}$	0.61	0.65	0.69	V
		$\Delta V/\Delta t = 200\text{ mV}/\mu\text{s}$	0.64	0.68	0.72	
$V_{\text{sense(fb)red(f)}}$	frequency reduction flyback sense voltage	$\Delta V/\Delta t = 50\text{ mV}/\mu\text{s}$	0.305	0.325	0.345	V
$t_{\text{leb(fb)}}$	flyback leading edge blanking time		255	305	355	ns
$I_{\text{adj(FBSENSE)}}$	adjust current on pin FBSENSE		-3.2	-3	-2.8	μA
Overpower protection flyback (pin FBSENSE)						
$V_{\text{sense(fb)max}}$	maximum flyback sense voltage	$\Delta V/\Delta t = 50\text{ mV}/\mu\text{s}$				
		$I_{\text{FBAUX}} = 80\text{ }\mu\text{A}$	0.61	0.65	0.69	V
		$I_{\text{FBAUX}} = 120\text{ }\mu\text{A}$	0.57	0.62	0.67	V
		$I_{\text{FBAUX}} = 240\text{ }\mu\text{A}$	0.47	0.52	0.57	V
		$I_{\text{FBAUX}} = 360\text{ }\mu\text{A}$	0.41	0.46	0.51	V
Driver (pin FBDRIVER)						
$I_{\text{src(FBDRIVER)}}$	source current on pin FBDRIVER	$V_{\text{FBDRIVER}} = 2\text{ V}$	-	-0.5	-	A
$I_{\text{sink(FBDRIVER)}}$	sink current on pin FBDRIVER	$V_{\text{FBDRIVER}} = 2\text{ V}$	-	0.7	-	A
		$V_{\text{FBDRIVER}} = 10\text{ V}$	-	1.2	-	A
$V_{\text{O(FBDRIVER)(max)}}$	maximum output voltage on pin FBDRIVER		-	11	12	V
LATCH input (pin LATCH)						
$V_{\text{prot(LATCH)}}$	protection voltage on pin LATCH		1.23	1.25	1.27	V
$I_{\text{O(LATCH)}}$	output current on pin LATCH	$V_{\text{prot(LATCH)}} < V_{\text{LATCH}} < V_{\text{oc(LATCH)}}$	-85	-80	-75	μA
$V_{\text{en(LATCH)}}$	enable voltage on pin LATCH	at start-up	1.30	1.35	1.40	V
$V_{\text{hys(LATCH)}}$	hysteresis voltage on pin LATCH	$V_{\text{en(LATCH)}} - V_{\text{prot(LATCH)}}$	80	100	140	mV
$V_{\text{oc(LATCH)}}$	open-circuit voltage on pin LATCH		2.65	2.9	3.15	V
Temperature protection						
$T_{\text{pl(IC)}}$	IC protection level temperature		130	140	150	$^{\circ}\text{C}$
$T_{\text{pl(IC)hys}}$	hysteresis of IC protection level temperature		-	10	-	$^{\circ}\text{C}$

[1] For a typical application with a compensation network on pin PFCCOMP, like the example in [Figure 3](#).

[2] Minimum required voltage change time for valley recognition on pin PFCAUX.

[3] Minimum time required between demagnetization detection and $\Delta V/\Delta t = 0$ on pin PFCAUX.

[4] Hysteresis for PFC on/off control.

[5] Guaranteed by design.

11. Application information

A power supply with the TEA1753T consists of a power factor correction circuit followed by a flyback converter. See [Figure 17](#).

Capacitor C_{VCC} buffers the IC supply voltage, which is powered via the high voltage rectified mains during start-up and via the auxiliary winding of the flyback converter during operation. Sense resistors R_{SENSE1} and R_{SENSE2} convert the current through the MOSFETs S1 and S2 into a voltage at pins PFCSENSE and FBSENSE. The values of R_{SENSE1} and R_{SENSE2} define the maximum primary peak current in MOSFETS S1 and S2.

In the example given, the LATCH pin is connected to a Negative Temperature Coefficient (NTC) resistor. The protection is activated when the resistance drops below a value as calculated below.

$$\frac{V_{prot(LATCH)}}{I_{O(LATCH)}} = 15.6 \text{ k}\Omega \tag{8}$$

A capacitor $C_{TIMEOUT}$ is connected to the FBCTRL pin. For a 120 nF capacitor, the time-out protection is activated after 10 ms. R_{LOOP} is added so that the time-out capacitor does not interfere with the normal regulation loop.

R_{S1} and R_{S2} are added to prevent the soft start capacitors from being charged during normal operation due to negative voltage spikes across the sense resistors.

Resistor R_{AUX1} is added to protect the IC from damage during lightning events.

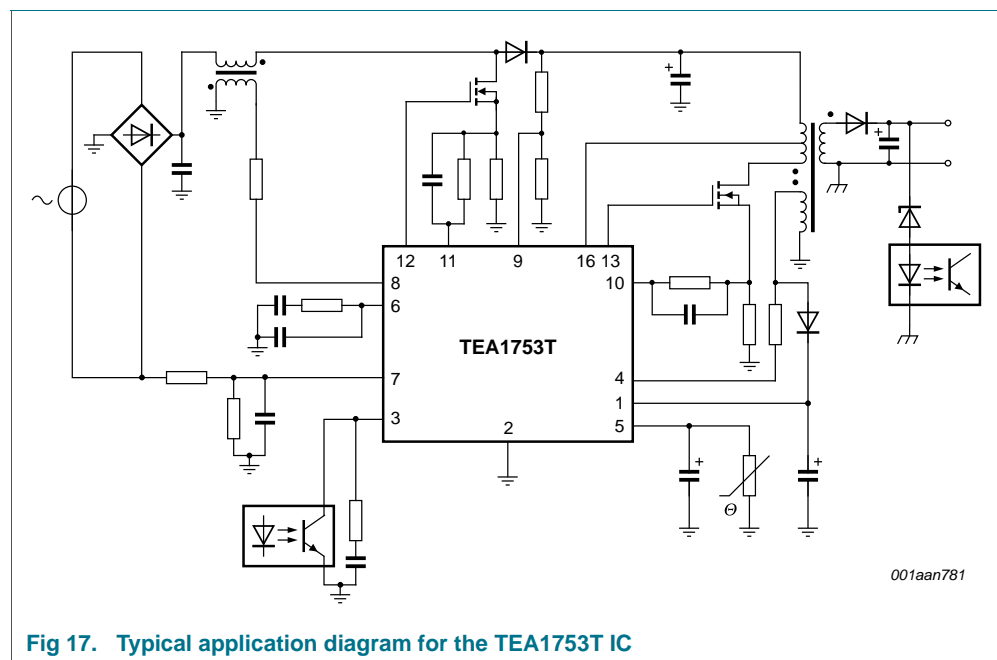

Fig 17. Typical application diagram for the TEA1753T IC

12. Package outline

SO16: plastic small outline package; 16 leads; body width 3.9 mm

SOT109-1

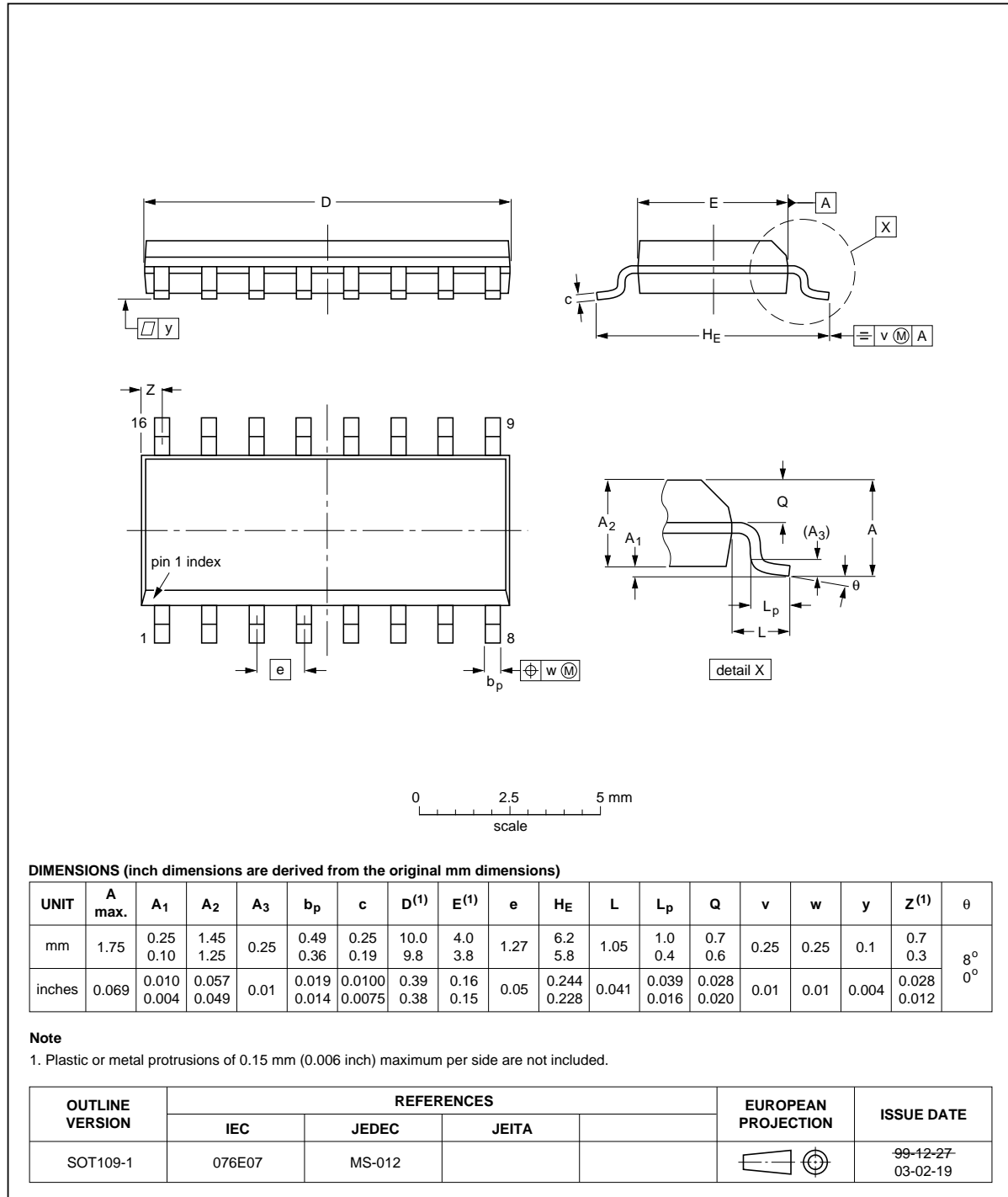

Fig 18. Package outline SOT109-1 (SO16)

13. Revision history

Table 6. Revision history

Document ID	Release date	Data sheet status	Change notice	Supersedes
TEA1753T v.1	20110304	Objective data sheet	-	-

14. Legal information

14.1 Data sheet status

Document status ^{[1][2]}	Product status ^[3]	Definition
Objective [short] data sheet	Development	This document contains data from the objective specification for product development.
Preliminary [short] data sheet	Qualification	This document contains data from the preliminary specification.
Product [short] data sheet	Production	This document contains the product specification.

[1] Please consult the most recently issued document before initiating or completing a design.

[2] The term 'short data sheet' is explained in section "Definitions".

[3] The product status of device(s) described in this document may have changed since this document was published and may differ in case of multiple devices. The latest product status information is available on the Internet at URL <http://www.nxp.com>.

14.2 Definitions

Draft — The document is a draft version only. The content is still under internal review and subject to formal approval, which may result in modifications or additions. NXP Semiconductors does not give any representations or warranties as to the accuracy or completeness of information included herein and shall have no liability for the consequences of use of such information.

Short data sheet — A short data sheet is an extract from a full data sheet with the same product type number(s) and title. A short data sheet is intended for quick reference only and should not be relied upon to contain detailed and full information. For detailed and full information see the relevant full data sheet, which is available on request via the local NXP Semiconductors sales office. In case of any inconsistency or conflict with the short data sheet, the full data sheet shall prevail.

Product specification — The information and data provided in a Product data sheet shall define the specification of the product as agreed between NXP Semiconductors and its customer, unless NXP Semiconductors and customer have explicitly agreed otherwise in writing. In no event however, shall an agreement be valid in which the NXP Semiconductors product is deemed to offer functions and qualities beyond those described in the Product data sheet.

14.3 Disclaimers

Limited warranty and liability — Information in this document is believed to be accurate and reliable. However, NXP Semiconductors does not give any representations or warranties, expressed or implied, as to the accuracy or completeness of such information and shall have no liability for the consequences of use of such information.

In no event shall NXP Semiconductors be liable for any indirect, incidental, punitive, special or consequential damages (including - without limitation - lost profits, lost savings, business interruption, costs related to the removal or replacement of any products or rework charges) whether or not such damages are based on tort (including negligence), warranty, breach of contract or any other legal theory.

Notwithstanding any damages that customer might incur for any reason whatsoever, NXP Semiconductors' aggregate and cumulative liability towards customer for the products described herein shall be limited in accordance with the *Terms and conditions of commercial sale* of NXP Semiconductors.

Right to make changes — NXP Semiconductors reserves the right to make changes to information published in this document, including without limitation specifications and product descriptions, at any time and without notice. This document supersedes and replaces all information supplied prior to the publication hereof.

Suitability for use — NXP Semiconductors products are not designed, authorized or warranted to be suitable for use in life support, life-critical or safety-critical systems or equipment, nor in applications where failure or

malfunction of an NXP Semiconductors product can reasonably be expected to result in personal injury, death or severe property or environmental damage. NXP Semiconductors accepts no liability for inclusion and/or use of NXP Semiconductors products in such equipment or applications and therefore such inclusion and/or use is at the customer's own risk.

Applications — Applications that are described herein for any of these products are for illustrative purposes only. NXP Semiconductors makes no representation or warranty that such applications will be suitable for the specified use without further testing or modification.

Customers are responsible for the design and operation of their applications and products using NXP Semiconductors products, and NXP Semiconductors accepts no liability for any assistance with applications or customer product design. It is customer's sole responsibility to determine whether the NXP Semiconductors product is suitable and fit for the customer's applications and products planned, as well as for the planned application and use of customer's third party customer(s). Customers should provide appropriate design and operating safeguards to minimize the risks associated with their applications and products.

NXP Semiconductors does not accept any liability related to any default, damage, costs or problem which is based on any weakness or default in the customer's applications or products, or the application or use by customer's third party customer(s). Customer is responsible for doing all necessary testing for the customer's applications and products using NXP Semiconductors products in order to avoid a default of the applications and the products or of the application or use by customer's third party customer(s). NXP does not accept any liability in this respect.

Limiting values — Stress above one or more limiting values (as defined in the Absolute Maximum Ratings System of IEC 60134) will cause permanent damage to the device. Limiting values are stress ratings only and (proper) operation of the device at these or any other conditions above those given in the Recommended operating conditions section (if present) or the Characteristics sections of this document is not warranted. Constant or repeated exposure to limiting values will permanently and irreversibly affect the quality and reliability of the device.

Terms and conditions of commercial sale — NXP Semiconductors products are sold subject to the general terms and conditions of commercial sale, as published at <http://www.nxp.com/profile/terms>, unless otherwise agreed in a valid written individual agreement. In case an individual agreement is concluded only the terms and conditions of the respective agreement shall apply. NXP Semiconductors hereby expressly objects to applying the customer's general terms and conditions with regard to the purchase of NXP Semiconductors products by customer.

No offer to sell or license — Nothing in this document may be interpreted or construed as an offer to sell products that is open for acceptance or the grant, conveyance or implication of any license under any copyrights, patents or other industrial or intellectual property rights.

Export control — This document as well as the item(s) described herein may be subject to export control regulations. Export might require a prior authorization from national authorities.

Non-automotive qualified products — Unless this data sheet expressly states that this specific NXP Semiconductors product is automotive qualified, the product is not suitable for automotive use. It is neither qualified nor tested in accordance with automotive testing or application requirements. NXP Semiconductors accepts no liability for inclusion and/or use of non-automotive qualified products in automotive equipment or applications.

In the event that customer uses the product for design-in and use in automotive applications to automotive specifications and standards, customer (a) shall use the product without NXP Semiconductors' warranty of the product for such automotive applications, use and specifications, and (b) whenever customer uses the product for automotive applications beyond NXP Semiconductors' specifications such use shall be solely at customer's

own risk, and (c) customer fully indemnifies NXP Semiconductors for any liability, damages or failed product claims resulting from customer design and use of the product for automotive applications beyond NXP Semiconductors' standard warranty and NXP Semiconductors' product specifications.

14.4 Trademarks

Notice: All referenced brands, product names, service names and trademarks are the property of their respective owners.

GreenChip — is a trademark of NXP B.V.

15. Contact information

For more information, please visit: <http://www.nxp.com>

For sales office addresses, please send an email to: salesaddresses@nxp.com

16. Contents

1	General description	1	7.3.10	Overpower protection	19
2	Features and benefits	2	7.3.11	Driver (pin FBDRIVER)	19
2.1	Distinctive features	2	8	Limiting values	20
2.2	Green features	2	9	Thermal characteristics	21
2.3	PFC green features	2	10	Characteristics	21
2.4	Flyback green features	2	11	Application information	26
2.5	Protection features	2	12	Package outline	27
3	Applications	2	13	Revision history	28
4	Ordering information	3	14	Legal information	29
5	Block diagram	4	14.1	Data sheet status	29
6	Pinning information	5	14.2	Definitions	29
6.1	Pinning	5	14.3	Disclaimers	29
6.2	Pin description	5	14.4	Trademarks	30
7	Functional description	6	15	Contact information	30
7.1	General control	6	16	Contents	31
7.1.1	Start-up and UnderVoltage LockOut (UVLO)	6			
7.1.2	Power down	8			
7.1.3	Supply management	9			
7.1.4	Latch input	9			
7.1.5	Fast latch reset	9			
7.1.6	Overtemperature protection	9			
7.2	Power factor correction circuit	9			
7.2.1	t_{on} control	9			
7.2.2	Valley switching and demagnetization (PFCAUX pin)	10			
7.2.3	Frequency limitation	10			
7.2.4	Mains voltage compensation (VINSENSE pin)	10			
7.2.5	Soft start-up (pin PFCSENSE)	10			
7.2.6	Low power mode	11			
7.2.7	PFC off delay (pin PFCTIMER)	11			
7.2.8	Dual boost PFC	12			
7.2.9	Overcurrent protection (PFCSENSE pin)	12			
7.2.10	Mains undervoltage lockout / brownout protection (VINSENSE pin)	12			
7.2.11	Overvoltage protection (VOSENSE pin)	13			
7.2.12	PFC open-loop protection (VOSENSE pin)	13			
7.2.13	Driver (pin PFCDRIVER)	13			
7.3	Flyback controller	13			
7.3.1	Multimode operation	13			
7.3.2	Valley switching (HV pin)	14			
7.3.3	Current mode control (FBSENSE pin)	15			
7.3.4	Demagnetization (FBAUX pin)	16			
7.3.5	Flyback control / time-out (FBCTRL pin)	16			
7.3.6	Soft start-up (pin FBSENSE)	17			
7.3.7	Maximum on-time	18			
7.3.8	Overvoltage protection (FBAUX pin)	18			
7.3.9	Overcurrent protection (FBSENSE pin)	19			

Please be aware that important notices concerning this document and the product(s) described herein, have been included in section 'Legal information'.

© NXP B.V. 2011.

All rights reserved.

For more information, please visit: <http://www.nxp.com>

For sales office addresses, please send an email to: salesaddresses@nxp.com

Date of release: 4 March 2011

Document identifier: TEA1753T