

# DATA SHEET

## **TEA1096; TEA1096A** Speech and listening-in IC

Product Specification  
File under Integrated Circuits, IC03

November 1994

**Philips Semiconductors**



**PHILIPS**

## Speech and listening-in IC

## TEA1096; TEA1096A

### FEATURES

- Line Interface with:
  - active set impedance (adjustable)
  - voltage regulator with adjustable DC voltage
  - low voltage circuit for parallel operation
- Interface to peripheral circuits with:
  - supply  $V_{DD}$  for microcontroller
  - stabilized supply voltage ( $V_{BB}$ ) which is: available for peripheral circuits adjustable (TEA1096 only)
  - Dual-Tone MultiFrequency (DTMF) signal input
  - power-down function for pulse dialling/flash
  - mute function to disable speech during dialling
- Microphone amplifier with:
  - symmetrical high impedance inputs
  - externally adjustable gain
  - AGC; line-loss compensation
  - dynamic limiter
  - microphone mute function
- Receiving amplifier with:
  - externally adjustable gain
  - confidence tone during dialling
  - double anti-sidetone circuit for long and short lines
  - AGC; line-loss compensation
  - earpiece protection by soft clipping.
- Listening-in circuit with:
  - loudspeaker amplifier
  - dynamic limiter to prevent distortion at any supply condition
  - volume control via a potentiometer
  - fixed gain of 35.5 dB
  - disable function
  - gain control input (TEA1096A only).

### APPLICATIONS

- Line-powered telephone sets with listening-in/line monitoring function.

### DIFFERENCES BETWEEN TEA1096 AND TEA1096A

The TEA1096 offers via input VBA an adjustable stabilized supply voltage  $V_{BB}$ , whereas the TEA1096A offers a fixed stabilized voltage  $V_{BB}$ .

The TEA1096A offers a DC gain control input VCI to set the loudspeaker volume, whereas the TEA1096 offers volume control via a potentiometer.

### GENERAL DESCRIPTION

The TEA1096 and TEA1096A are bipolar ICs intended for use in line powered telephone sets. They offer a speech/transmission function, listening-in and line monitoring facilities of the received line signal via the loudspeaker.

The devices incorporate a line interface block, a microphone and DTMF amplifier, a receiving amplifier, a supply function, a loudspeaker amplifier, and a dynamic limiter in the transmission channel and the listening-in channel.

### ORDERING INFORMATION

TYPE NUMBER	PACKAGE		
	NAME	DESCRIPTION	VERSION
TEA1096	DIP28	plastic dual in-line package; 28 leads (600 mil)	SOT117-1
TEA1096A	DIP28	plastic dual in-line package; 28 leads (600 mil)	SOT117-1
TEA1096T	SO28	plastic small outline package; 28 leads; body width 7.5 mm	SOT136-1
TEA1096AT	SO28	plastic small outline package; 28 leads; body width 7.5 mm	SOT136-1

## Speech and listening-in IC

## TEA1096; TEA1096A

## QUICK REFERENCE DATA

SYMBOL	PARAMETER	CONDITIONS	MIN.	TYP.	MAX.	UNIT
$I_{line}$	line current	normal condition	15	–	140	mA
		with reduced performance	–	–	15	mA
$I_{DD}$	current consumption from pin $V_{DD}$ during normal operation	PD = LOW	–	2.4	2.9	mA
$I_{DD(PD)}$	current consumption from capacitor $C_{VDD}$ during power-down	PD = HIGH	–	100	150	$\mu$ A
$I_{BB(PD)}$	current consumption from capacitor $C_{VBB}$ during power-down	PD = HIGH	–	350	500	$\mu$ A
$V_{SLPE}$	stabilized voltage (line interface)		4.2	4.45	4.7	V
$V_{DD}$	supply voltage for microcontroller	$R_{DD} = 390 \Omega$ ; $I_P = 0$ mA	–	3.5	–	V
		$R_{DD} = 390 \Omega$ ; $I_P = 1$ mA	–	3.1	–	V
$V_{BB}$	stabilized supply voltage		3.4	3.6	3.8	V
$G_{vtx}$	voltage gain from pin MICP or MICM to LN	$V_{MIC} = 2$ mV (RMS); $R_{GAS} = 90.9$ k $\Omega$ ; $I_{line} = 20$ mA	51	52	53	dB
$\Delta G_{vtxr}$	voltage gain adjustment with $R_{GAS}$		–19	–	0	dB
$G_{vrX}$	voltage gain from pin LN to QRP or QRM	$V_{line} = 50$ mV (RMS); $R_{GAR} = 90.9$ k $\Omega$ ; $I_{line} = 20$ mA	–3.5	–2.5	–1.5	dB
$\Delta G_{vrXr}$	voltage gain adjustment with $R_{GAR}$		–12	–	8	dB
$\Delta G_{trX}$	line-loss compensation	$R_{AGC} = 100$ k $\Omega$	5	6	7	dB
$G_{vlX}$	voltage gain from pin LSI to QLS	$V_{LSI} = 10$ mV (RMS)	34	35.5	37	dB
$V_{LN(p-p)}$	maximum output voltage swing on pin LN (peak-to-peak value)		–	3.65	4.3	V
$V_{QLS(p-p)}$	output voltage between pins QLS and $V_{EE}$ (peak-to-peak value)	$V_{LSI} = 18$ mV; $I_{line} = 20$ mA	2.5	2.9	–	mA
$T_{amb}$	operating ambient temperature		–25	–	+75	$^{\circ}$ C

Speech and listening-in IC

TEA1096; TEA1096A

BLOCK DIAGRAMS

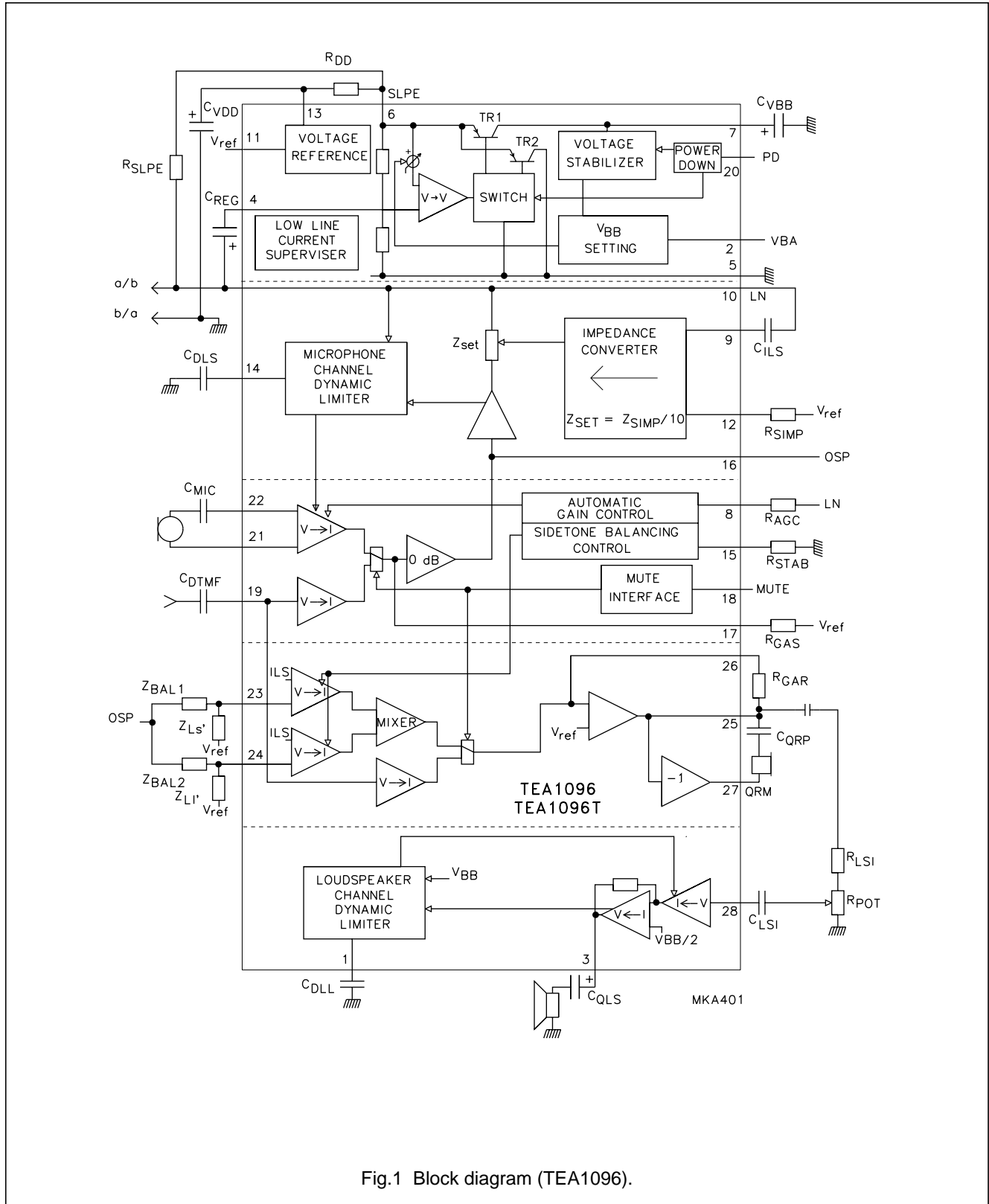

Fig.1 Block diagram (TEA1096).

Speech and listening-in IC

TEA1096; TEA1096A

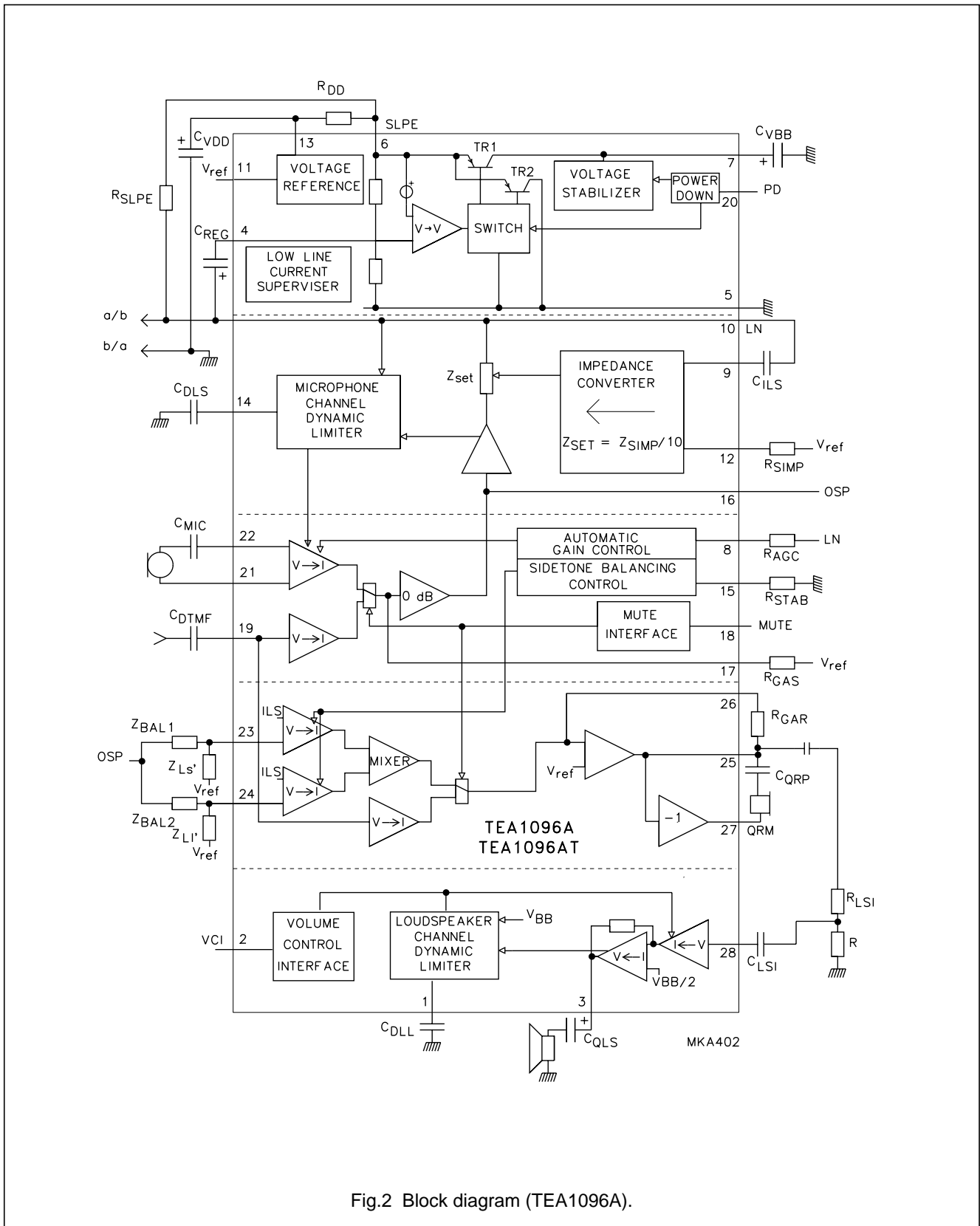

Fig.2 Block diagram (TEA1096A).

## Speech and listening-in IC

## TEA1096; TEA1096A

## PINNING

SYMBOL	PINS		DESCRIPTION
	TEA1096	TEA1096A	
DLL/DIL	1	1	dynamic limiter and disable input for loudspeaker amplifier
VBA	2	–	$V_{BB}$ voltage adjustment
VCI	–	2	volume control input for loudspeaker amplifier
QLS	3	3	loudspeaker amplifier output
REG	4	4	decoupling line voltage stabilizer
$V_{EE}$	5	5	negative line terminal (ground reference)
SLPE	6	6	stabilized voltage, connection for slope resistor
$V_{BB}$	7	7	stabilized supply voltage for listening-in circuitry
AGC	8	8	automatic gain control
ILS	9	9	input line signal
LN	10	10	positive line terminal
$V_{ref}$	11	11	reference voltage output
SIMP	12	12	set impedance input
$V_{DD}$	13	13	supply voltage for speech circuitry/peripherals
DLS/MMUTE	14	14	dynamic limiter for sending and microphone mute
STAB	15	15	reference current adjustment
OSP	16	16	sending preamplifier output
GAS	17	17	sending gain adjustment
MUTE	18	18	mute input to select speech or DTMF dialling
DTMF	19	19	dual-tone multi-frequency (DTMF) input
PD	20	20	power-down input
MICM	21	21	inverting microphone amplifier input
MICP	22	22	non-inverting microphone amplifier input
BAL1	23	23	connection for balance network 1
BAL2	24	24	connection for balance network 2
QRP	25	25	non-inverting receiving amplifier output
GAR	26	26	receiving gain adjustment
QRM	27	27	inverting receiving amplifier output
LSI	28	28	loudspeaker amplifier input

Speech and listening-in IC

TEA1096; TEA1096A

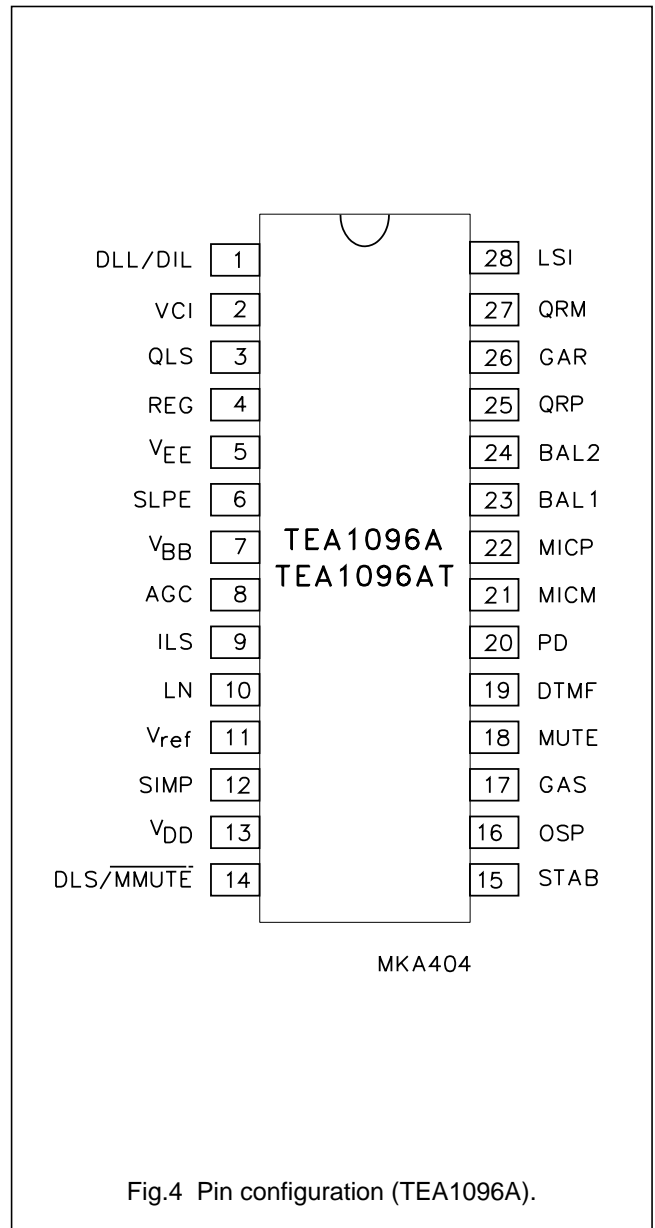
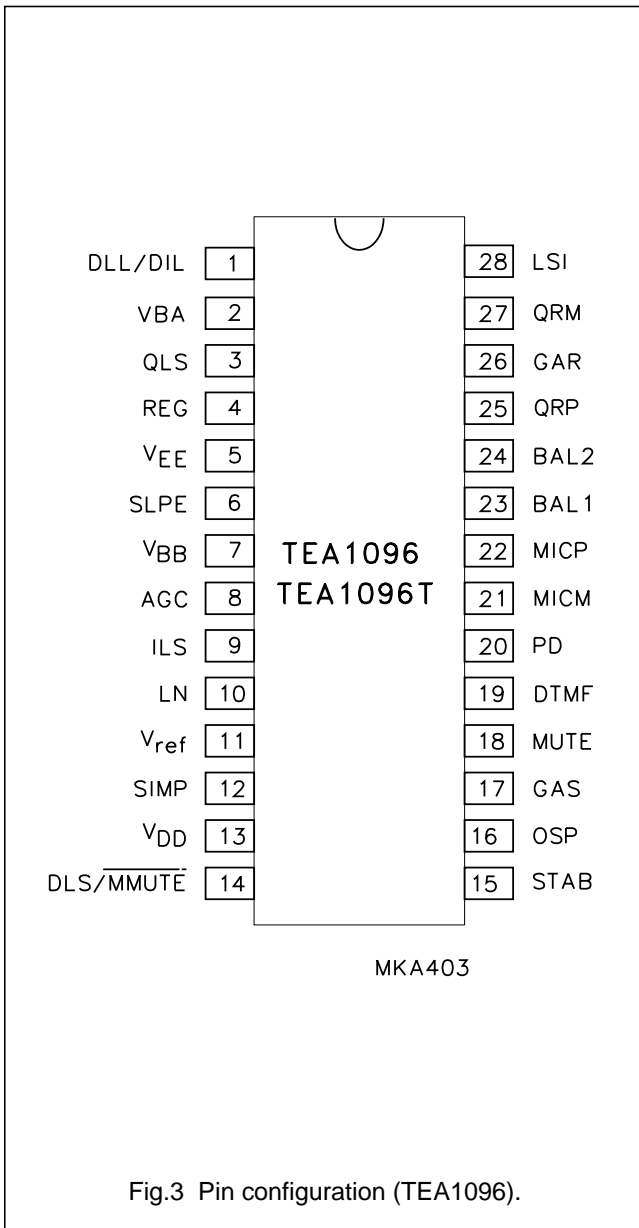

Speech and listening-in IC

TEA1096; TEA1096A

**FUNCTIONAL DESCRIPTION**

**Remark:** all data given in this chapter are typical values except when otherwise specified.

**Supply pins SLPE, LN, V<sub>EE</sub>, V<sub>BB</sub>, V<sub>DD</sub>, REG and PD**

The supply for the TEA1096/TEA1096A and its peripherals is obtained from the telephone line. The circuits regulate the line voltage and generate their own supply voltages V<sub>DD</sub> and V<sub>BB</sub> to power the transmission part and the loudspeaker amplifier respectively.

As can be seen from Fig.5, the line current (I<sub>line</sub>) is split between the sending output stage (I<sub>in</sub>), the circuitry connected to SLPE (I<sub>sl</sub>), the transmission circuit (I<sub>DD</sub>), the peripheral circuits (I<sub>p</sub>) and the current switch (I<sub>SUP</sub>). It can be shown that:

$$I_{SUP} = I_{line} - (I_{in} + I_{sl} + I_{DD} + I_p)$$

With nominal conditions where:

$$I_{in} = 5 \text{ mA}, I_{sl} = 0.3 \text{ mA and } I_{DD} = 2.4 \text{ mA}$$

it therefore follows that I<sub>SUP</sub> ≈ I<sub>line</sub> - 7.7 mA - I<sub>p</sub>.

The remaining current I<sub>SUP</sub> is available for the listening-in part. The current consumption I<sub>BBO</sub> of the listening-in circuitry is 2.5 mA. To power the loudspeaker, the line current has to be more than 10 mA.

The voltage at SLPE is stabilized at 4.45 V nominal. The DC line voltage is regulated at:

$$V_{LN} = V_{SLPE} + R_{SLPE} \times (I_{line} - I_{in}).$$

The supply voltage for the transmission part and peripheral circuits (V<sub>DD</sub>) is generated from V<sub>SLPE</sub> and is equal to V<sub>DD</sub> = V<sub>SLPE</sub> - R<sub>DD</sub> × (I<sub>DD</sub> + I<sub>p</sub>).

V<sub>BB</sub> supplies the listening-in circuitry and is stabilized at 3.6 V nominal.

A resistor connected between pin REG and V<sub>EE</sub> can be used to decrease the SLPE voltage while maintaining V<sub>BB</sub> at its nominal value, whereas a resistor connected between pin REG and pin SLPE will increase the SLPE voltage while maintaining V<sub>BB</sub> at its nominal value. When adjusting the SLPE voltage to a lower value, care should be taken that the V<sub>SLPE</sub> is at least 0.4 V higher than V<sub>BB</sub> (V<sub>BB</sub> supply efficiency).

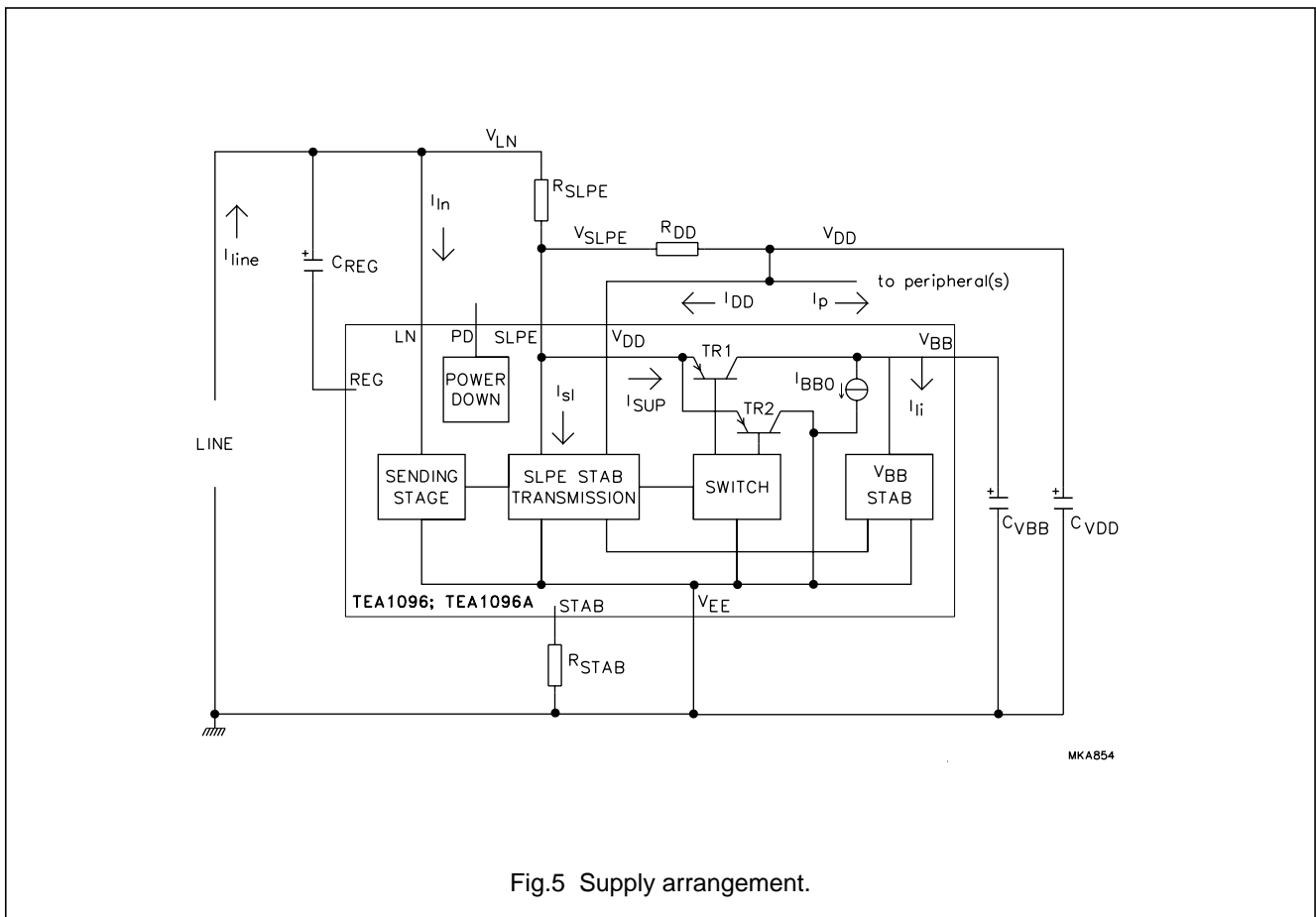

Fig.5 Supply arrangement.



Speech and listening-in IC

TEA1096; TEA1096A

The function of the current switch TR1-TR2 is to reduce distortion of large line signals. Current  $I_{SUP}$  is supplied to  $V_{BB}$  via TR1, when  $V_{SLPE}$  is higher than  $V_{BB} + 0.4$  V. When  $V_{SLPE}$  is lower, this current is shunted to  $V_{EE}$  via TR2. All excess line current, not used for internal supply is consumed in the  $V_{BB}$  stabilizer or directly shunted to  $V_{EE}$ .

To reduce the current consumption during pulse dialling, the TEA1096/TEA1096A are provided with a power-down (PD) input. The PD input has a pull-down structure. When the voltage on PD is HIGH, the current consumption from  $V_{DD}$  capacitor  $C_{VDD}$  is 100  $\mu$ A and from the  $V_{BB}$  supply point 350  $\mu$ A. The capacitors  $C_{VDD}$  (100  $\mu$ F) and  $C_{VBB}$  (470  $\mu$ F) are sufficient to power the TEA1096/TEA1096A during pulse dialling/flash.

**$V_{BB}$  voltage adjustment: pin VBA (TEA1096 only)**

A resistor connected between pins VBA and  $V_{EE}$  can be used to increase the  $V_{BB}$  voltage, whereas a resistor connected between pins VBA and  $V_{BB}$  will decrease the  $V_{BB}$  voltage. When adjusting the  $V_{BB}$  voltage to a higher value, care should be taken that  $V_{SLPE}$  is at least 0.4 V higher than  $V_{BB}$  ( $V_{BB}$  supply efficiency).

**Sending channel: pins MICP, MICM, DTMF, GAS, OSP, LN, MUTE, DLS and AGC**

The TEA1096/TEA1096A has symmetrical microphone inputs MICP, MICM with an input resistance of 64 k $\Omega$  between MICP and MICM ( $2 \times 32$  k $\Omega$ ). In the speech mode (MUTE = LOW), the overall gain from MICP-MICM to LN can be adjusted from 33 dB to 52 dB to suit specific requirements. The gain is proportional to the value of  $R_{GAS}$  and equals 52 dB with  $R_{GAS} = 90.9$  k $\Omega$  and  $I_{line} = 20$  mA. A capacitor  $C_{GAS}$  connected in parallel with  $R_{GAS}$  can be used to provide a first-order low-pass filter.

Automatic gain control (AGC) is provided for line-loss compensation as well as dynamic limitation for reduction of the distortion of the transmitted signal on the line. The microphone amplifier can be disabled by short-circuiting pin DLS to  $V_{EE}$  (secret function) and can be muted into DTMF mode by applying a HIGH level on pin MUTE.

The TEA1096/TEA1096A has an asymmetrical DTMF input with an input resistance of 20 k $\Omega$ . In the DTMF mode, the overall gain from DTMF to LN is proportional to  $R_{GAS}$ , and is 26.5 dB less than the microphone amplifier gain. Switch-over from one mode to the other is click-free.

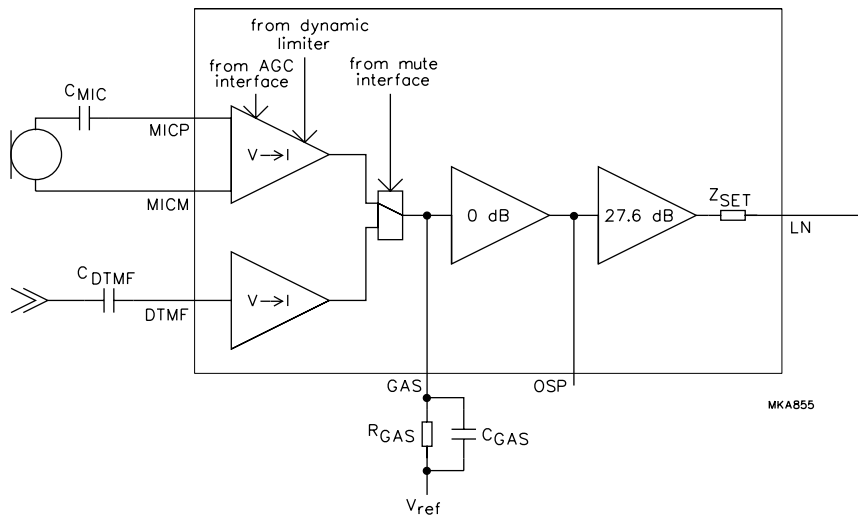

Fig.6 Sending channel.

Speech and listening-in IC

TEA1096; TEA1096A

It can be calculated from Fig.7 that the AC modulator gain can be written:

- $$\frac{V_{LN}}{V_{OSP}} = \frac{Z_{line}}{(Z_{line} + Z_{SET}) \times 24} = 12$$
 providing  $Z_{SET} = Z_{line}$
- $G_v (LN \text{ to } OSP) = 21.6 \text{ dB.}$

The frequency response for audio frequencies of the sending channel is flat in this case for a complex line termination.

**Set impedance: pins ILS, SIMP and LN**

The TEA1096/TEA1096A provides an active set impedance in both the receiving and sending conditions, thus allowing a flat frequency response for a complex line impedance, without the need for any extra compensation network.

As can be derived from Fig.8 the set impedance  $Z_{SET}$  is 10 times lower than  $Z_{SIMP}$ .

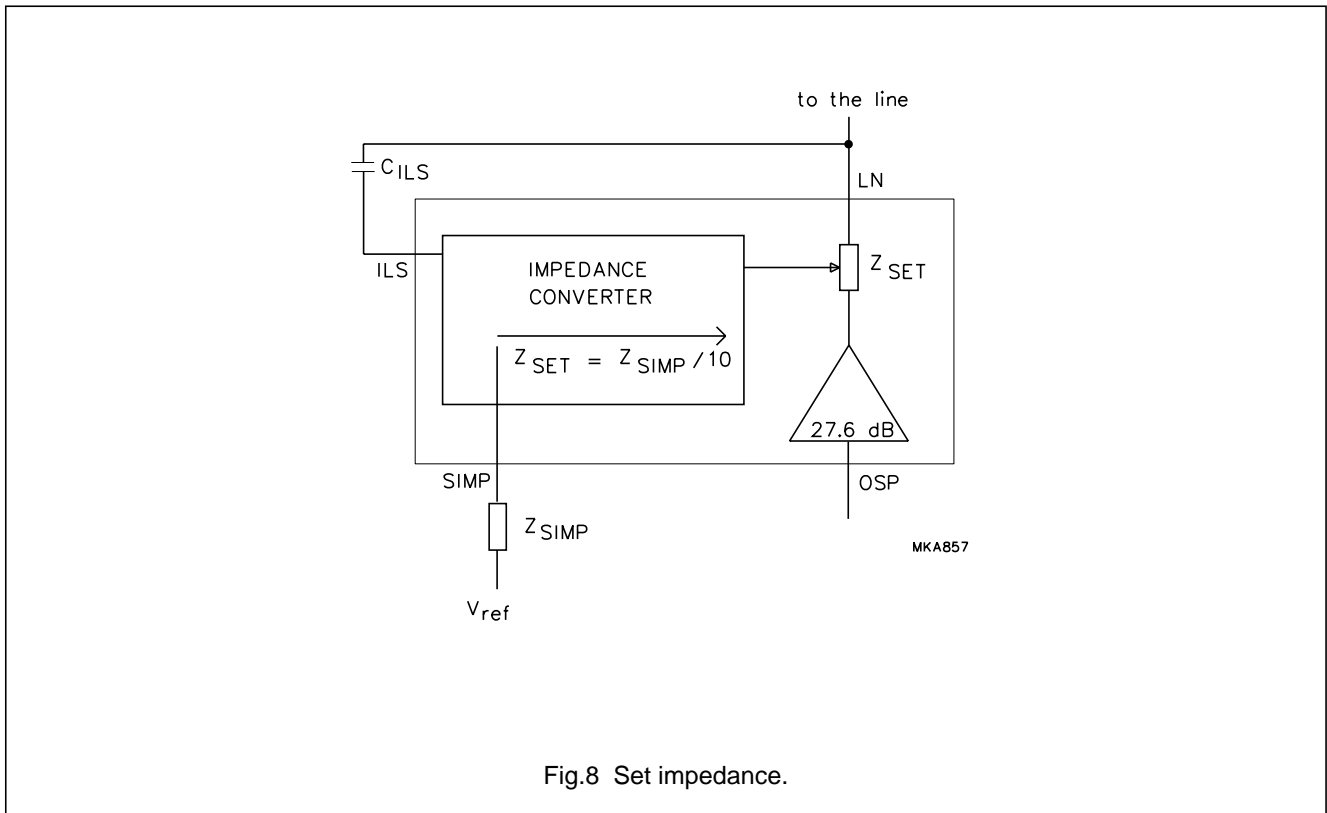
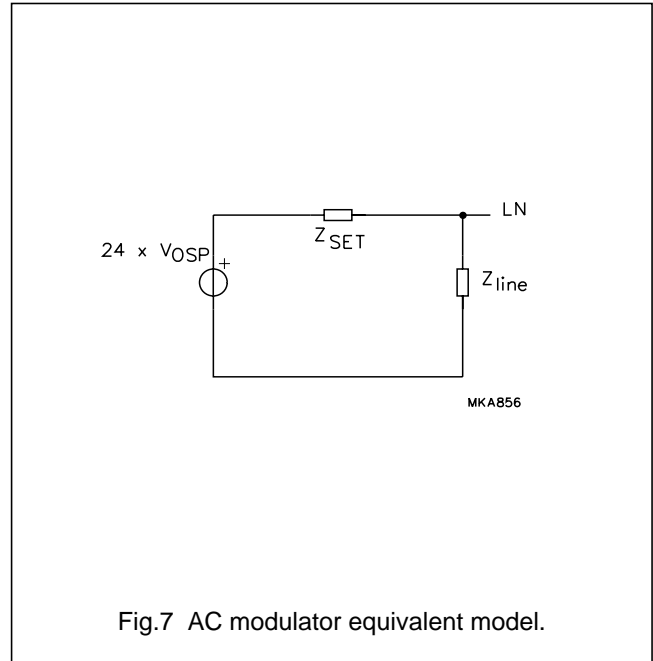

Speech and listening-in IC

TEA1096; TEA1096A

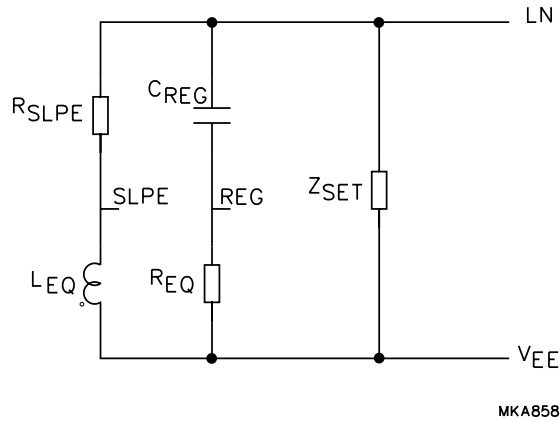

Fig.9 Equivalent AC impedance between LN and V<sub>EE</sub>.

The equivalent impedance connected between LN and V<sub>EE</sub> is illustrated in Fig.9.

Where:

- $L_{EQ} = R_{EQ} \times C_{REG} \times R_{SLPE}$
- $R_{EQ} = 40 \text{ k}\Omega$
- $Z_{SET} = \frac{1}{10} Z_{SIMP}$ .

**Remark:** a resistor R (REG-V<sub>EE</sub>) connected between REG and V<sub>EE</sub> (to lower the regulated voltage) changes R<sub>EQ</sub> into R<sub>EQ</sub> // R (REG-V<sub>EE</sub>), whereas a resistor R<sub>REG-SLPE</sub> connected between REG and SLPE (to increase the regulated voltage) has no effect on R<sub>EQ</sub>.

**Dynamic limiter of the microphone channel: pin DLS**

The dynamic limiter in the microphone channel of the TEA1096/TEA1096A prevents clipping of the microphone signal, and limits the transmitted signal on LN to a maximum value of typically 3.65 V (4.4 dBm).

Clipping on the microphone channel is prevented by rapidly reducing the gain when the output stage starts to saturate. The time in which the gain reduction is effected (clipping attack time) is approximately a few milliseconds. The microphone channel stays in the reduced gain mode until the peaks of the signal no longer cause saturation. The gain of the microphone channel then returns to its normal value within the clipping release time.

Both attack and release time are proportional to the value of the capacitor C<sub>DLS</sub>. The THD (Total Harmonic Distortion) of the microphone amplifier in the reduced gain mode stays below 2% up to 10 dB of input voltage overdrive [provided that V<sub>MICP</sub>, V<sub>MICM</sub> is below 10 mV (RMS)].

The dynamic limiter of the TEA1096/TEA1096A also provides a microphone mute (secret function) when pin DLS is short-circuited to V<sub>EE</sub>. The microphone gain is then 80 dB lower. The release time after a microphone mute is approximately 10 ms.

## Speech and listening-in IC

## TEA1096; TEA1096A

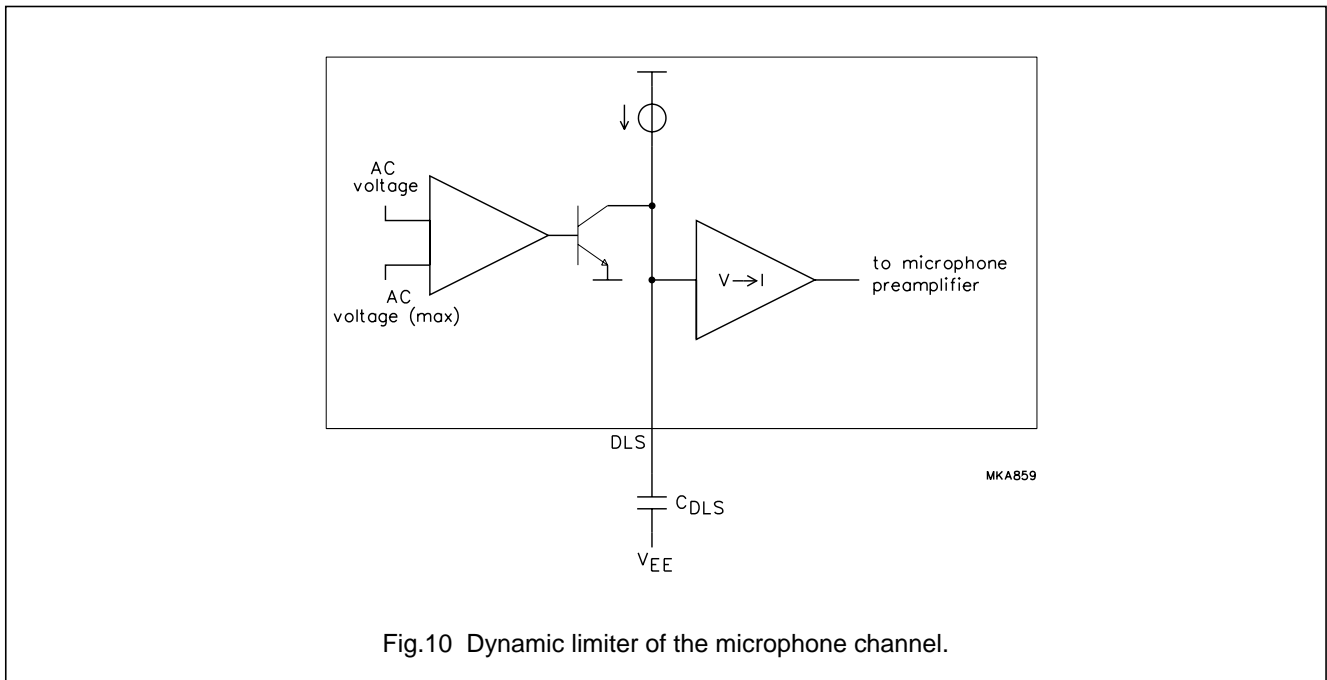
**Receiving amplifier: pins LN, GAR, QRP and QRM**

The receiver gain is defined between the line connection LN and the earpiece complementary outputs QRP (non-inverting) and QRM (inverting). With  $R_{GAR}$  equal to 90.9 k $\Omega$  the gain from LN to QRP is -2.5 dB. The outputs may be used to connect a dynamic, magnetic or piezoelectric earpiece. When the earpiece impedance exceeds 450  $\Omega$ , differential drive (BTL connection) can be used. As both outputs are in opposite phase, the gain from LN to QRP or QRM is 3.5 dB.

By means of the  $R_{GAR}$  resistor, the gain of the receiving amplifier can be adjusted to suit the sensitivity of the transducer which is used. The permitted range is between -14 dB and +6 dB for single-ended drive (SE), and between -8 dB and +12 dB for bridge-tied load (BTL) drive.

Two external capacitors,  $C_{GAR}$  (100 pF) and  $C_{GARS}$  (1 nF), ensure stability. The  $C_{GAR}$  capacitor is also used to obtain a first-order low-pass filter. The cut-off frequency (corresponding to the time constant  $R_{GAR} \times C_{GAR}$ ) can be adjusted by the  $C_{GAR}$  capacitor, but the relationship  $C_{GARS} = C_{GAR} \times 10$  must be maintained.

During DTMF dialling, the dialling tones can be heard in the earpiece at a very low level. This is called confidence tone.

**Automatic gain control: pin AGC**

Automatic compensation of line-loss is obtained by connecting a resistor  $R_{AGC}$  between pin LN and pin AGC. This automatic gain control changes the gain of the microphone and receiving amplifiers in accordance with the DC line current.

The control range is 6 dB; This corresponds to a 5 km line of 0.5 mm diameter copper twisted-pair cable:

$$\text{DC resistance} = 176 \Omega / \text{km}$$

$$\text{average attenuation} = 1.2 \text{ dB/km.}$$

The value of  $R_{AGC}$  must be chosen with reference to the exchange supply voltage and its feeding bridge resistance and has no influence on the ratio ( $I_{start}/I_{stop}$ ) which remains constant. Figure 11 illustrates the gain attenuation when  $R_{AGC} = 100 \text{ k}\Omega$ . If automatic line-loss compensation is not required, the AGC pin can be left open circuit, the amplifiers then give their maximum gain and the double sidetone principle is no longer active. Only one network is used. Pins BAL1 and BAL2 must then be short-circuited together.

Speech and listening-in IC

TEA1096; TEA1096A

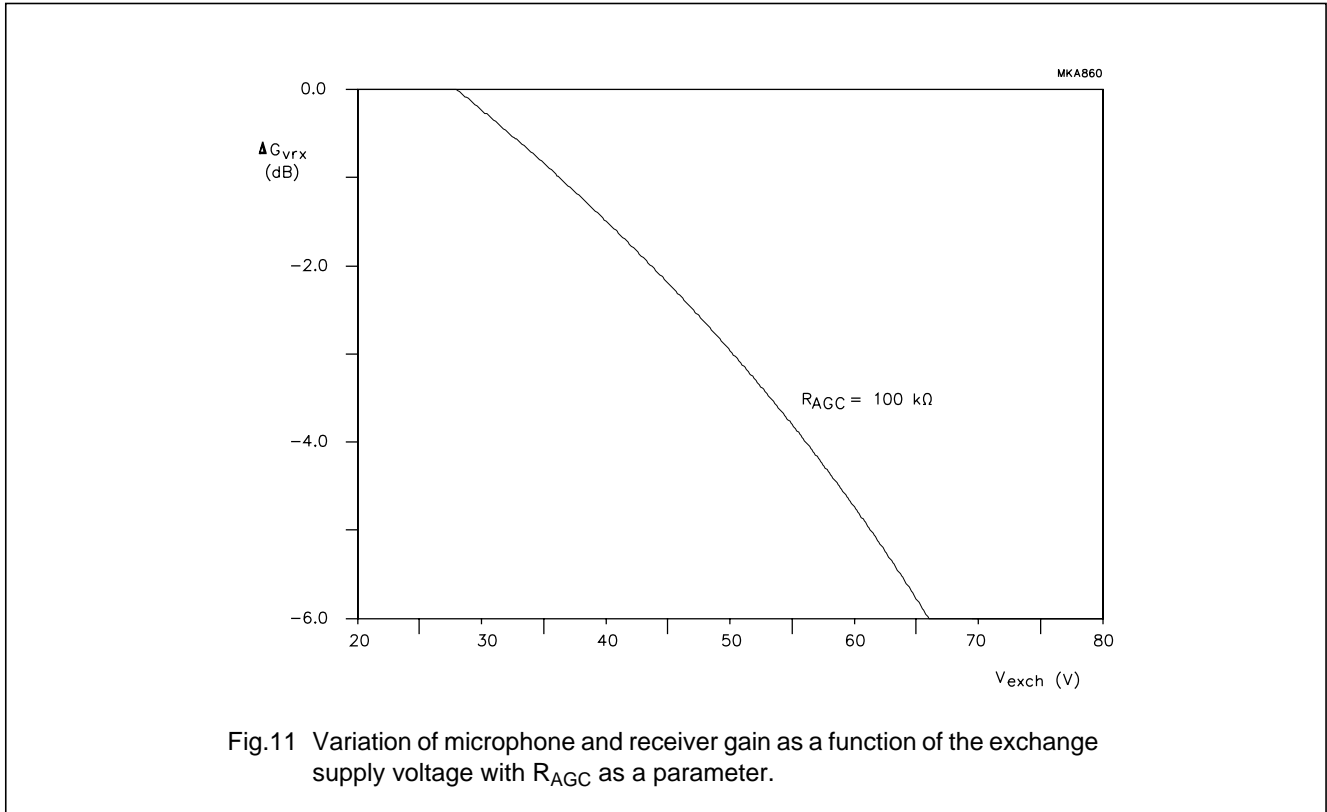

Fig.11 Variation of microphone and receiver gain as a function of the exchange supply voltage with  $R_{AGC}$  as a parameter.

**Sidetone suppression: pins BAL1, BAL2, OSP and ILS**

Suppression of the microphone signal in the earpiece is obtained by subtracting a part of this signal to a fraction of the line signal (see Fig.12). For optimum suppression, the voltage at the BAL inputs (BAL1 and BAL2) should be equal to:

$$V_{BAL} = 0.5 \times \frac{Z_{line}}{Z_{SET} \times Z_{line}} \times V_{SOP}$$

To reach this requirement, an anti-sidetone network using two impedances  $Z_{BAL}$  and  $Z_{LI'}$  is needed.

In the event of real impedances, the anti-sidetone network is composed of resistors connected as shown in Fig.13.

Where:  $R_{LI'} = \alpha \times R_{line}$  and  $R_{BAL} = \alpha \times R_{SET}$ ;

where  $\alpha$  is a scale factor allowing to have  $R_{LI'}$  in the order of 10 kΩ (DC biasing to  $V_{ref}$  has to be ensured on BAL1 and BAL2).

In the event of complex impedances, the equivalent network  $Z_s$ , representing  $Z_{line}$ , has to be transformed into  $Z_p$  in accordance with Fig.14.

The components of  $Z_p$ , scaled by a factor  $\alpha$ , are applied in anti-sidetone network  $Z_{LI'}$ . The complete anti-sidetone network is shown in Fig.15.

Speech and listening-in IC

TEA1096; TEA1096A

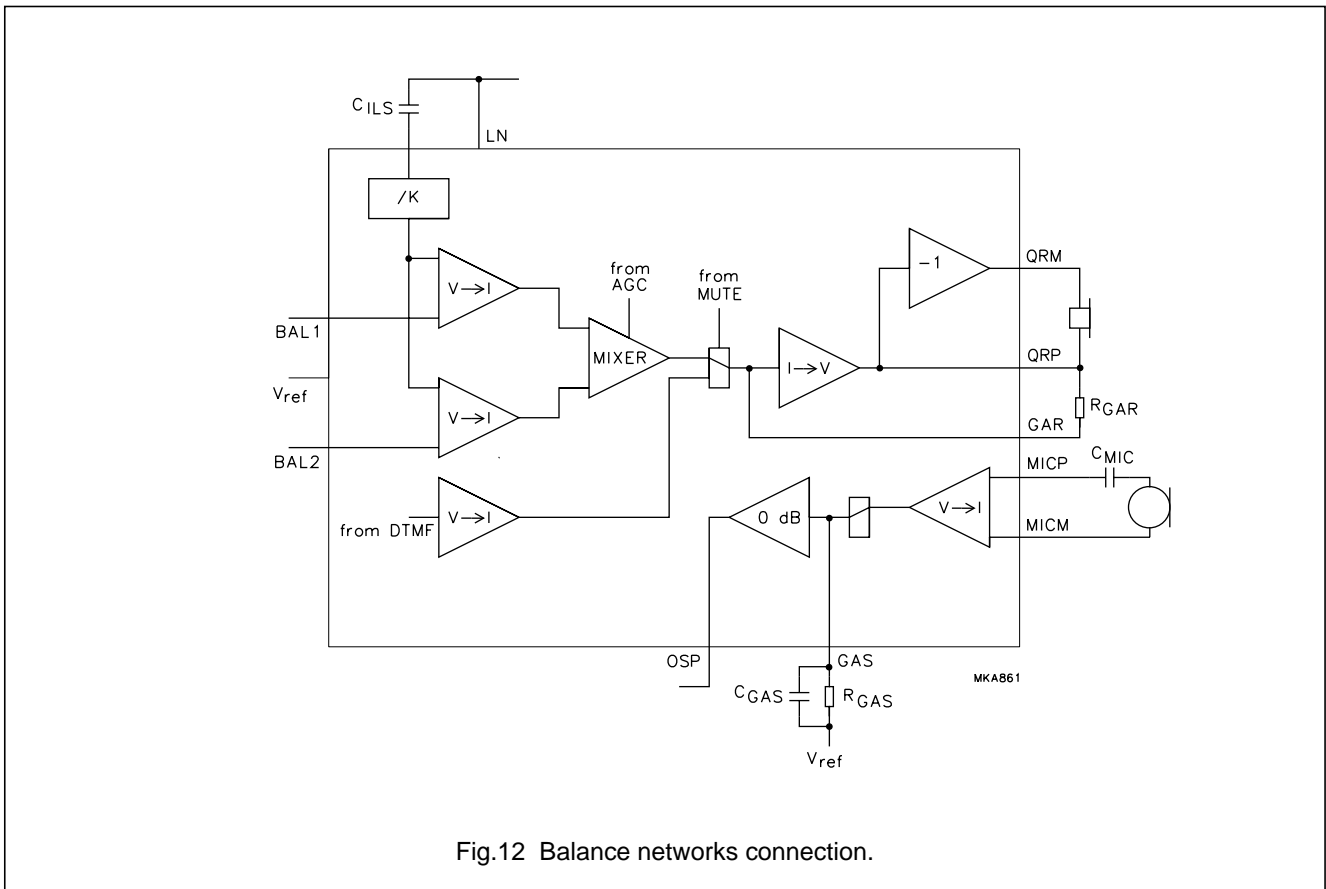

Fig.12 Balance networks connection.

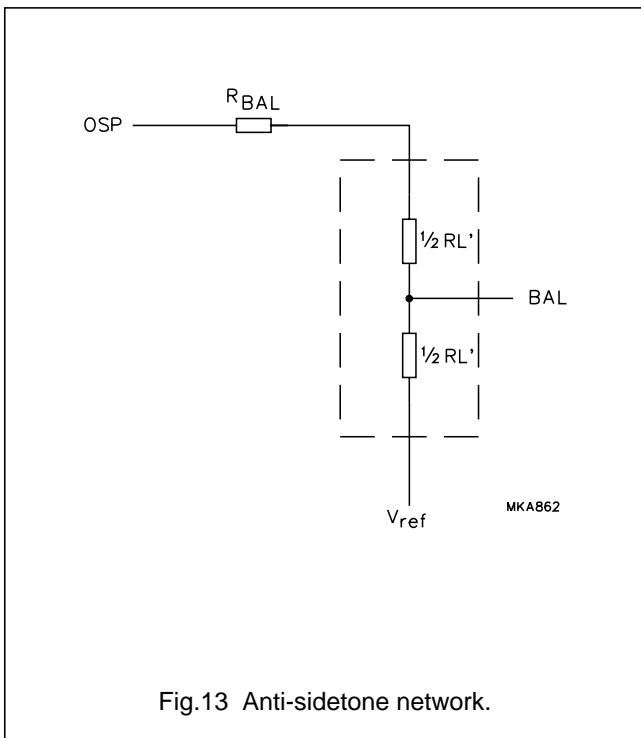
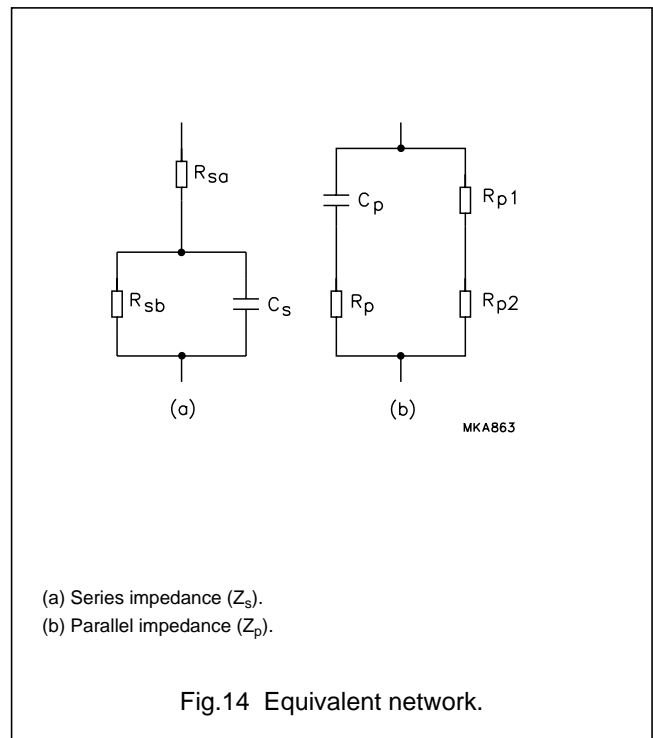

Fig.13 Anti-sidetone network.



(a) Series impedance ( $Z_s$ ).  
 (b) Parallel impedance ( $Z_p$ ).

Fig.14 Equivalent network.

Speech and listening-in IC

TEA1096; TEA1096A

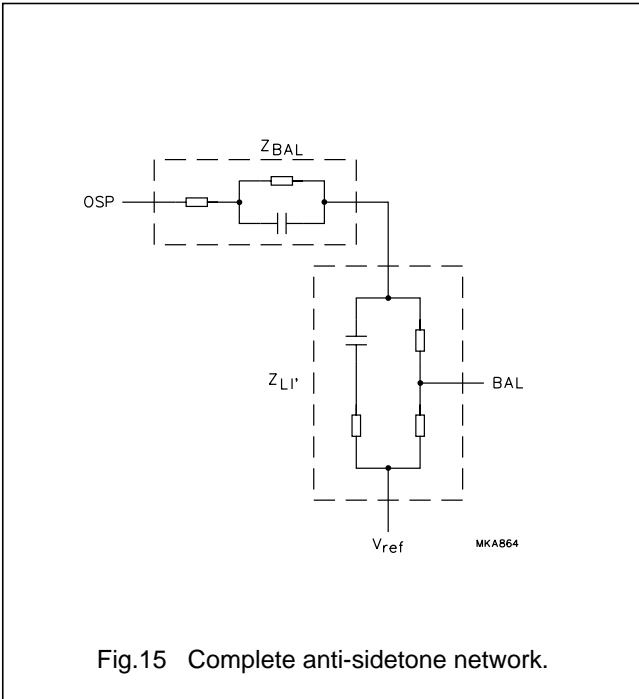

Fig.15 Complete anti-sidetone network.

Again, it means that:  $Z_{LI'} = \alpha \times Z_{line}$  and  $Z_{BAL} = \alpha \times Z_{SET}$

Where  $\alpha$  is a scale factor allowing  $Z_{LI'}$  to be in the order of 10 k $\Omega$  (DC biasing to  $V_{ref}$  has to be ensured on BAL1 and BAL2).

As the line impedance  $Z_{line}$  varies considerably with the line length, two anti-sidetone networks can be used. One of them  $Z_{LI'}$ , connected to BAL2 is optimized for long lines, the other one  $Z_{LS'}$ , connected to BAL1 is optimized for short lines:

Where:

$$Z_{LI'} = \alpha \times Z_{line} \text{ (long)}$$

$$Z_{LS'} = \alpha \times Z_{line} \text{ (short)}$$

$$Z_{BAL1} = \alpha \times Z_{SET}$$

$$Z_{BAL2} = \alpha \times Z_{SET}$$

Switching from one network to the other is carried out continuously with the line current, when the  $R_{AGC}$  resistor is connected. When the  $R_{AGC}$  resistor is not connected, switching from one network to the other is not possible (see automatic gain control). Only one network has then to be applied.

It is also possible to use only one anti-sidetone network. In this event, both inputs BAL1 and BAL2 must be short-circuited.

**Loudspeaker amplifier: pins LSI and QLS**

The loudspeaker amplifier has an asymmetrical input LSI which is referenced to an internal voltage reference of 1.25 V via an internal resistance of 10 k $\Omega$ . The input signal can be taken from one of the earpiece outputs QRP or QRM via a potentiometer ( $R_{POT}$ ). The attenuation has to be chosen in accordance with the gain  $G_{vrx}$  of the receiving amplifier.

The input stage can handle up to 200 mV (RMS) at room temperature for 3% of THD.

The gain of the loudspeaker amplifier is fixed at 35.5 dB. The output QLS is referenced to a DC level of  $\frac{1}{2}V_{BB}$  to offer rail-to-rail output swing.

The maximum voltage gain from line to loudspeaker has to be fixed in relation to the side-tone transfer of the telephone set. An enlarged listening-in gain improves the listening-in behaviour but can introduce audible instabilities in the form of howling during normal use of the set. The loudspeaker can be disabled by short-circuiting DLL/DIL input to  $V_{EE}$ .

## Speech and listening-in IC

## TEA1096; TEA1096A

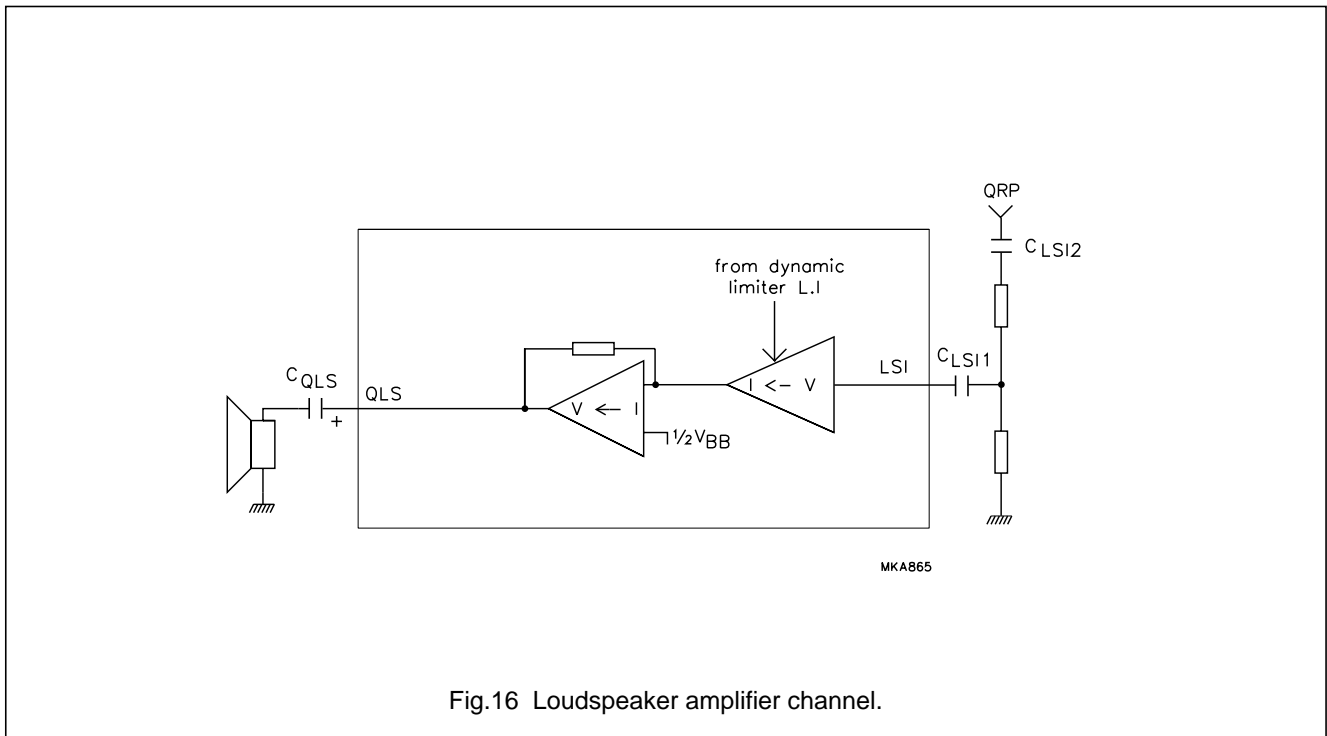

Fig.16 Loudspeaker amplifier channel.

**Dynamic limiter/loudspeaker amplifier disabling;  
pin DLL/DIL**

The dynamic limiter in the loudspeaker channel of the TEA1096/TEA1096A prevents clipping of the loudspeaker output stage and protects the functioning of the circuit when low supply conditions are detected.

Hard clipping of the loudspeaker output stage is prevented by rapidly reducing the gain when the output stage starts to saturate. The time in which the gain reduction is effected (clipping attack time) is approximately a few milliseconds. The loudspeaker amplifier stays in the reduced gain mode until the peaks of the loudspeaker signals no longer start to cause saturation. The gain of the loudspeaker amplifier then returns to its normal value within the clipping release time. Both attack and release time are proportional to the value of the capacitor  $C_{DLL}$ . The THD of the loudspeaker amplifier in the reduced gain mode stays below 5% up to 10 dB of input voltage overdrive.

When the supply conditions drop below the required level, the gain of the loudspeaker amplifier is reduced in order to prevent the device from malfunctioning. When the supply current drops below the required level, the supply voltage  $V_{BB}$  decreases. In this condition, the gain of the loudspeaker amplifier is reduced slowly (approximately a few seconds). When the supply voltage continues to decrease and drops below an internal threshold of 2.8 V, the gain of the loudspeaker amplifier is rapidly reduced (approximately 1 ms). After returning to normal supply conditions, the gain of the loudspeaker amplifier is raised again.

The dynamic limiter also provides a loudspeaker disable when pin DLL/DIL is short-circuited to  $V_{EE}$ . The loudspeaker gain is then typically 80 dB lower. The release time is approximately 10 ms.



Speech and listening-in IC

TEA1096; TEA1096A

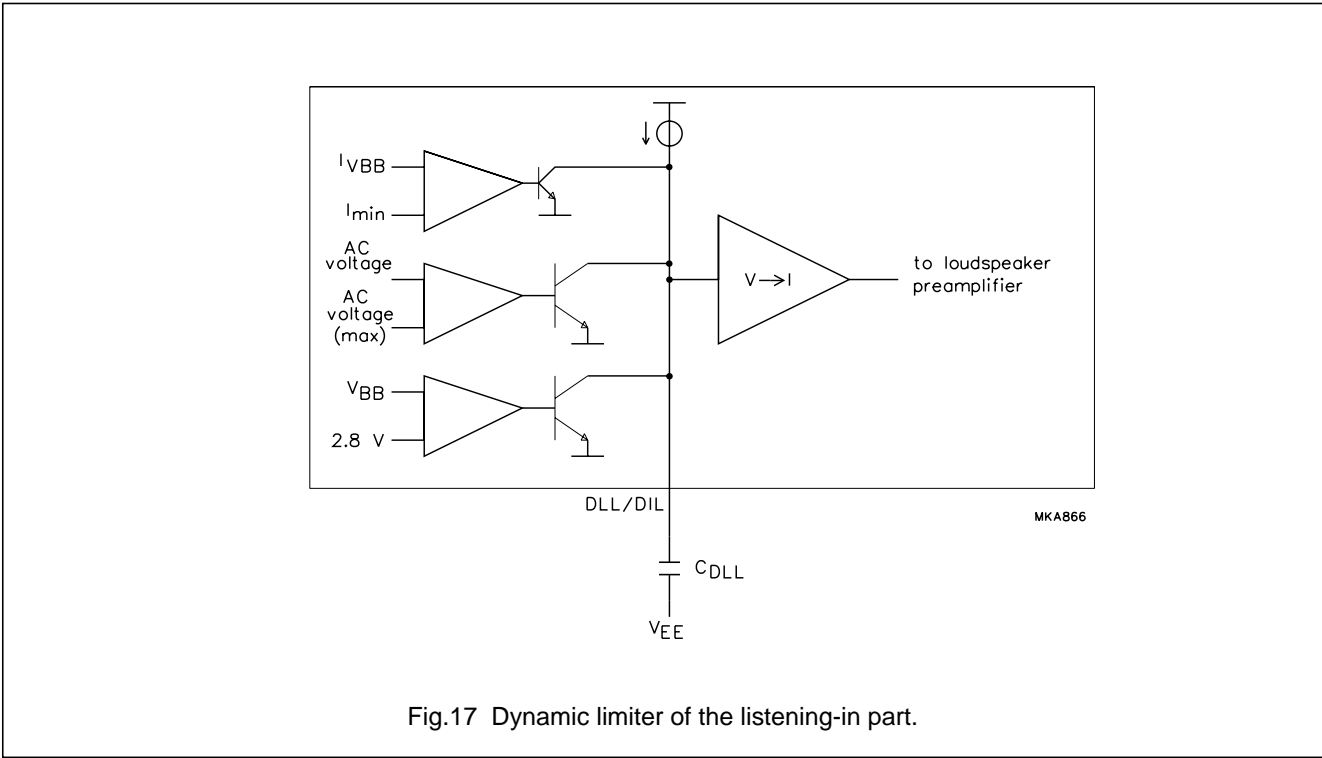

Fig.17 Dynamic limiter of the listening-in part.

**Volume control: pin VCI (TEA1096A only)**

The TEA1096A is provided with a volume control input VCI, to adjust the gain of the loudspeaker channel by means of a controlled DC voltage. A typical application is illustrated in Fig.18. A pulse width modulation on a microcontroller open drain output imposes a DC voltage on the VCI capacitor:

$$\text{Where } V_{VCI} = \frac{\delta \times K \times V_{BB}}{1 - \delta \times (1 - K)}$$

$$\text{with } \delta = \text{duty cycle and } K = \frac{R1}{R1 + R2}$$

A typical response is given in Fig.19.

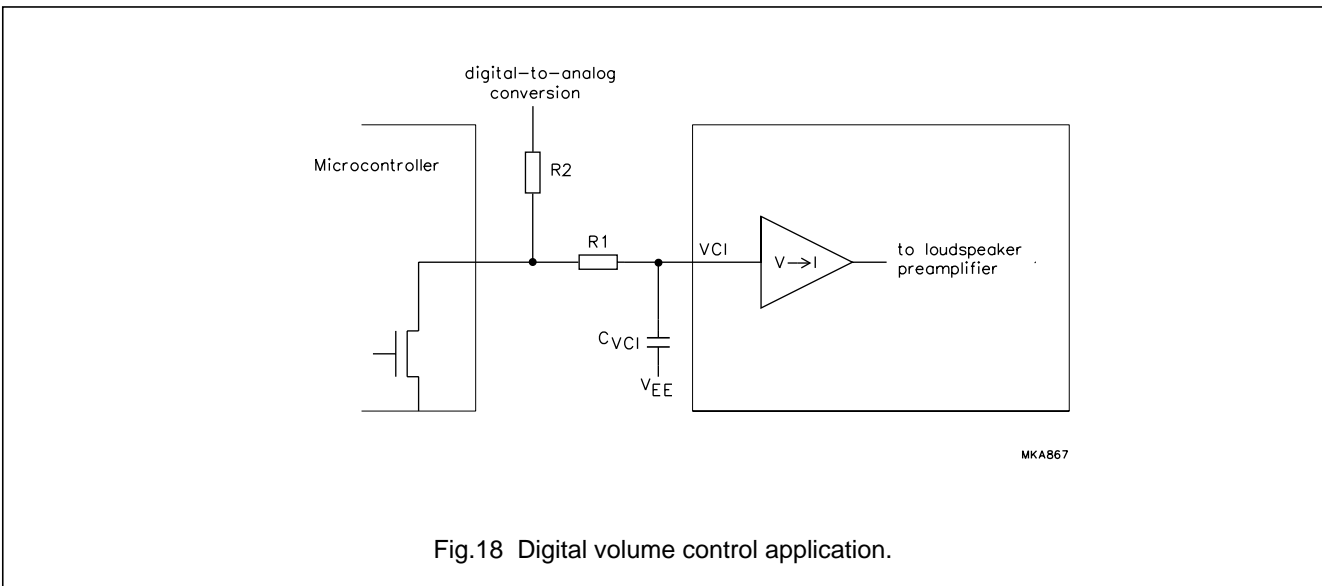

Fig.18 Digital volume control application.

Speech and listening-in IC

TEA1096; TEA1096A

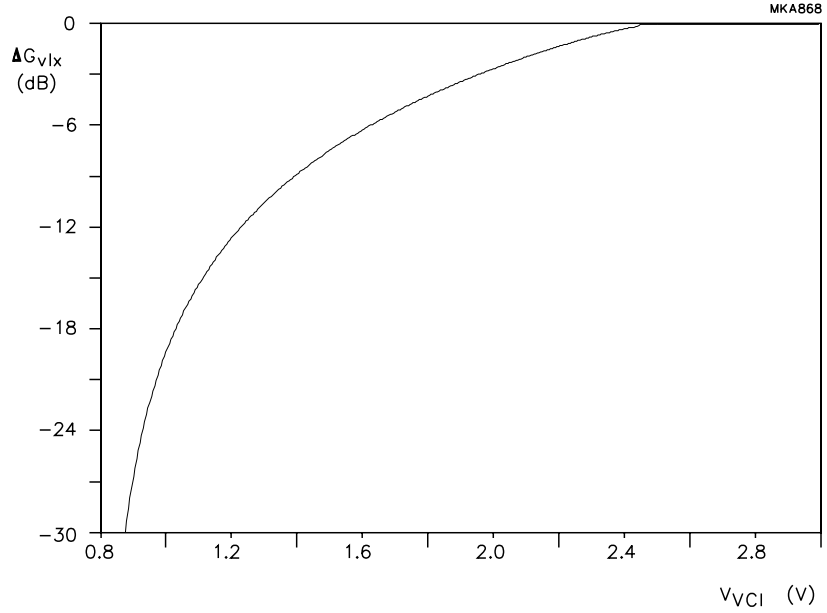

Fig.19 Change of loudspeaker gain as a function of the voltage at VCI.

## Speech and listening-in IC

## TEA1096; TEA1096A

**LIMITING VALUES**

In accordance with the Absolute Maximum Rating System (IEC 134).

SYMBOLS	PARAMETER	CONDITIONS	MIN.	MAX.	UNIT
$V_{LN}$	voltage on pin LN		$V_{EE} - 0.4$	12.0	V
$V_{DD}$	voltage on pin VDD		$V_{EE} - 0.4$	12.0	V
$V_{BB}$	voltage on pin VBB		$V_{EE} - 0.4$	12.0	V
$V_{n1}$	voltage on pins: REG, SLPE, AGC and ILS		$V_{EE} - 0.4$	$V_{LN} + 0.4$	V
$V_{n2}$	voltage on pins: DLL, VBA or VCI, QLS, LSI		$V_{EE} - 0.4$	$V_{BB} + 0.4$	V
$V_{n3}$	voltage on pins: $V_{ref}$ , SIMP, STAB, DLS, OSP, GAS, MUTE, DTMF, PD, MICM, MICP, BAL1, BAL2, QRP, QRM, GAR		$V_{EE} - 0.4$	$V_{DD} + 0.4$	V
$I_{line}$	line current	see also Figs 20 and 21	–	140	mA
$P_{tot}$	total power dissipation: TEA1096/TEA1096A TEA1096T/TEA1096AT	$T_{amb} = +75\text{ °C}$ ; see Figs 20 and 21	– –	0.91 0.66	W W
$T_{stg}$	storage temperature		–40	+125	°C
$T_{amb}$	operating ambient temperature		–25	+75	°C

**THERMAL CHARACTERISTICS**

SYMBOLS	PARAMETER	VALUE	UNIT
$R_{th\ j-a}$	thermal resistance from junction to ambient in free air: TEA1096; TEA1096A TEA1096T; TEA1096AT (note 1)	55 75	K/W K/W

**Note**

1. Mounted on epoxy board  $40.1 \times 19.1 \times 1.5$  mm.

Speech and listening-in IC

TEA1096; TEA1096A

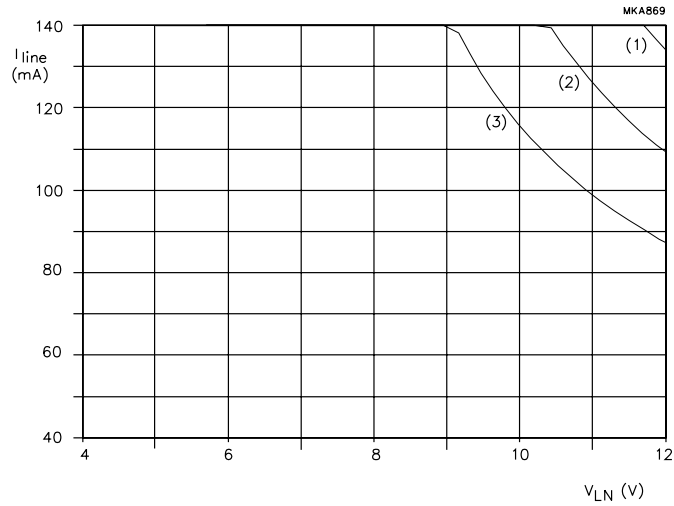

- (1) T<sub>amb</sub> = 55 °C; P<sub>tot</sub> = 1272 mW.
- (2) T<sub>amb</sub> = 65 °C; P<sub>tot</sub> = 1091 mW.
- (3) T<sub>amb</sub> = 75 °C; P<sub>tot</sub> = 910 mW.

Fig.20 TEA1096; TEA1096A safe operating area.

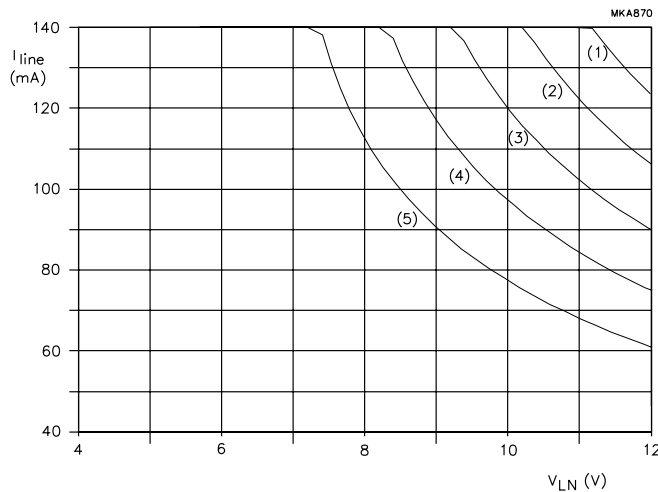

- (1) T<sub>amb</sub> = 35 °C; P<sub>tot</sub> = 1199 mW.
- (2) T<sub>amb</sub> = 45 °C; P<sub>tot</sub> = 1066 mW.
- (3) T<sub>amb</sub> = 55 °C; P<sub>tot</sub> = 933 mW.
- (4) T<sub>amb</sub> = 65 °C; P<sub>tot</sub> = 800 mW.
- (5) T<sub>amb</sub> = 75 °C; P<sub>tot</sub> = 667 mW.

Fig.21 TEA1096T; TEA1096AT safe operating area.

## Speech and listening-in IC

## TEA1096; TEA1096A

**CHARACTERISTICS**

$I_{line} = 20 \text{ mA}$ ;  $I_P = 0 \text{ mA}$ ;  $V_{EE} = 0 \text{ V}$ ; PD = LOW; MUTE = LOW;  $Z_{line} = 600 \Omega$ ;  $Z_{SIMP} = 6 \text{ k}\Omega$ ;  $Z_{BAL1} = 18 \text{ k}\Omega$ ;  $Z_{LI} = 6 \text{ k}\Omega$ ;  $R_{SLPE} = 20 \Omega$ ;  $R_{DD} = 390 \Omega$ ;  $R_{GAS} = 90.9 \text{ k}\Omega$ ;  $R_{GAR} = 0.9 \text{ k}\Omega$ ;  $R_{QLS} = 50 \Omega$ ;  $f = 1 \text{ kHz}$ ;  $T_{amb} = 25 \text{ }^\circ\text{C}$ ; measured in test circuit of Fig.22; unless otherwise specified.

SYMBOL	PARAMETER	CONDITIONS	MIN.	TYP.	MAX.	UNIT
<b>Line interface/supply (LN, SLPE, REG, V<sub>EE</sub>, V<sub>DD</sub>, V<sub>BB</sub> and V<sub>ref</sub>)</b>						
V <sub>SLPE</sub>	stabilized voltage (line interface)		4.2	4.45	4.7	V
$\Delta V_{SLPE(I_{line})}$	V <sub>SLPE</sub> variation with I <sub>line</sub>	I <sub>line</sub> = 20 to 140 mA	–	30	–	mV
$\Delta V_{SLPE(T)}$	V <sub>SLPE</sub> variation with temperature referenced to 25 °C	T <sub>amb</sub> = –25 to +75 °C	–150	±60	+150	mV
V <sub>BB</sub>	stabilized supply voltage		3.4	3.6	3.8	V
$\Delta V_{BB(I_{line})}$	V <sub>BB</sub> variation with I <sub>line</sub>	I <sub>line</sub> = 20 to 140 mA	–	30	–	mV
$\Delta V_{BB(T)}$	V <sub>BB</sub> variation with temperature referenced to 25 °C	T <sub>amb</sub> = –25 to +75 °C	–150	±50	+150	mV
I <sub>sink</sub>	current sunk by V <sub>BB</sub> shunt regulator when a line current equal to 20 mA is available	I <sub>P</sub> = 0 mA; note 1	–	9.0	–	mA
I <sub>DD</sub>	internal current consumption from pin V <sub>DD</sub>	I <sub>P</sub> = 0 mA; R <sub>DD</sub> = 390 Ω	–	2.4	2.9	mA
V <sub>DD</sub>	supply voltage for speech and microcontroller	R <sub>DD</sub> = 390 Ω; I <sub>P</sub> = 0 mA	–	3.5	–	V
		R <sub>DD</sub> = 390 Ω; I <sub>P</sub> = 1 mA	–	3.1	–	V
V <sub>ref</sub>	reference output voltage		–	0.5V <sub>DD</sub>	–	V
I <sub>DD(PD)</sub>	current consumption from C <sub>VDD</sub> during power-down condition	PD = HIGH; V <sub>DD</sub> = 4.3 V	–	100	150	μA
I <sub>BB(PD)</sub>	current consumption from C <sub>VBB</sub> during power-down condition	PD = HIGH; V <sub>BB</sub> = 3.5 V	–	350	500	μA
V <sub>LN</sub>	DC line voltage		4.4	4.7	5.0	V
V <sub>LN</sub>	DC line voltage in low current conditions	R <sub>DD</sub> = 390 Ω; I <sub>P</sub> = 0 mA; I <sub>line</sub> = 4 mA	–	2.5	–	V
		R <sub>DD</sub> = 390 Ω; I <sub>P</sub> = 0 mA; I <sub>line</sub> = 6 mA	–	3.3	–	V
<b>Microphone amplifier (MICP, MICM, GAS, LN, and MUTE)</b>						
Z <sub>i1</sub>	input impedance between pins MICP or MICM and V <sub>EE</sub>		25.5	32	38.5	kΩ
Z <sub>i2</sub>	input impedance between pins MICP and MICM		51	64	77	kΩ
G <sub>vtx</sub>	voltage gain from pin MICP or MICM to LN	V <sub>MIC</sub> = 2 mV (RMS); R <sub>GAS</sub> = 90.9 kΩ	51	52	53	dB
$\Delta G_{vtxT}$	voltage gain variation with temperature referenced to 25 °C.	V <sub>MIC</sub> = 2 mV (RMS); T <sub>amb</sub> = –25 to +75 °C	–	±0.5	–	dB

## Speech and listening-in IC

## TEA1096; TEA1096A

SYMBOL	PARAMETER	CONDITIONS	MIN.	TYP.	MAX.	UNIT
$\Delta G_{\text{vtxf}}$	voltage gain variation with frequency referenced to 1 kHz	$V_{\text{MIC}} = 2 \text{ mV (RMS)}$ ; $f = 300 \text{ to } 3400 \text{ Hz}$	–	$\pm 0.5$	–	dB
$\Delta G_{\text{vtxr}}$	voltage gain adjustment with $R_{\text{GAS}}$	note 2	–19	–	0	dB
$\Delta G_{\text{txm}}$	gain reduction with MUTE = HIGH		60	80	–	dB
$\Delta G_{\text{txd}}$	gain reduction when DLS/MMUTE is short-circuited to $V_{\text{EE}}$		60	80	–	dB
$V_{\text{LN(p-p)}}$	maximum output voltage swing at pin LN (peak-to-peak value)	$R_{\text{GAS}} = 90.9 \text{ k}\Omega$	–	3.65	4.3	V
$V_{\text{notx}}$	noise output voltage at pin LN	pins MICP and MICM short-circuited through $200 \text{ }\Omega$ ; Psophometrically weighted (P53 curve)	–	–72	–	dBmp
CMRR	common mode rejection ratio		–	80	–	dB
<b>Dynamic limiter for sending (DLS/MMUTE); related to the microphone amplifier clipping detector</b>						
$t_{\text{att}}$	attack time when $V_{\text{MIC}}$ jumps from 3.2 mV to 3.2 mV + 10 dB	$R_{\text{GAS}} = 90.9 \text{ k}\Omega$ ; $C_{\text{DLS}} = 470 \text{ nF}$	–	1.5	5	ms
$t_{\text{rel}}$	release time when $V_{\text{MIC}}$ drops from 3.2 mV + 10 dB to 3.2 mV	$R_{\text{GAS}} = 90.9 \text{ k}\Omega$ ; $C_{\text{DLS}} = 470 \text{ nF}$	40	120	–	ms
THD	total harmonic distortion	$V_{\text{MIC}} = 3.2 \text{ mV} + 10 \text{ dB}$ ; $R_{\text{GAS}} = 90.9 \text{ k}\Omega$ ; $C_{\text{DLS}} = 470 \text{ nF}$	–	2	3	%
		$V_{\text{MIC}} = 3.2 \text{ mV} + 15 \text{ dB}$ ; $R_{\text{GAS}} = 90.9 \text{ k}\Omega$ ; $C_{\text{DLS}} = 470 \text{ nF}$	–	3	10	%
<b>Receiving amplifier (ILS, BAL1, BAL2, OSP, GAR, QRP, QRM and MUTE)</b>						
$G_{\text{vrX}}$	voltage gain from pin LN to QRP or QRM	$R_{\text{GAR}} = 90.9 \text{ k}\Omega$ ; $V_{\text{line}} = 50 \text{ mV (RMS)}$ ; single-ended load; $R_{\text{QRP}} = 150 \text{ }\Omega$	–3.5	–2.5	–1.5	dB
		$R_{\text{GAR}} = 90.9 \text{ k}\Omega$ ; $V_{\text{line}} = 50 \text{ mV (RMS)}$ ; bridge tied load; $R_{\text{QRM}} = 450 \text{ }\Omega$	2.5	3.5	4.5	dB
$\Delta G_{\text{vrXT}}$	voltage gain variation with temperature referenced to 25 °C.	$T_{\text{amb}} = -25 \text{ to } +75 \text{ }^\circ\text{C}$	–	$\pm 0.5$	–	dB
$\Delta G_{\text{vrxf}}$	voltage gain variation with frequency referenced to 1 kHz	$f = 300 \text{ to } 3400 \text{ Hz}$	–	$\pm 0.5$	–	dB
$\Delta G_{\text{vrxr}}$	voltage gain adjustment with $R_{\text{GAR}}$		–12	–	8	dB

## Speech and listening-in IC

## TEA1096; TEA1096A

SYMBOL	PARAMETER	CONDITIONS	MIN.	TYP.	MAX.	UNIT
$V_{QR(rms)}$	maximum output voltage for THD = 2% (RMS value)	$R_{GAR} = 90.9 \text{ k}\Omega$ ; single-ended load; $R_{QRP} = 150 \text{ }\Omega$	0.3	0.375	–	V
		$R_{GAR} = 90.9 \text{ k}\Omega$ ; bridge-tied load; $R_{QRM} = 450 \text{ }\Omega$	0.6	0.72	–	V
		$R_{GAR} = 90.9 \text{ k}\Omega$ ; bridge-tied load with 300 $\Omega$ series resistor; $C_{QRM} = 60 \text{ nF}$ ; $f = 3400 \text{ Hz}$	0.75	0.95	–	V
$V_{norx(rms)}$	noise output voltage (RMS value)	Psophometrically weighted (P53 curve); single-ended load; $R_{QRP} = 150 \text{ }\Omega$	–	90	–	$\mu\text{V}$
		Psophometrically weighted (P53 curve); bridge-tied load; $R_{QRM} = 450 \text{ }\Omega$	–	180	–	$\mu\text{V}$
<b>DTMF amplifier (DTMF, LN, MUTE)</b>						
$ Z_i $	input impedance between pins DTMF and $V_{EE}$		16	20	24	$\text{k}\Omega$
$G_{vtx}$	voltage gain from pin DTMF to LN	$V_{DTMF} = 4 \text{ mV (RMS)}$ ; $R_{GAS} = 90.9 \text{ k}\Omega$	24.5	25.5	26.5	dB
$\Delta G_{vtxT}$	voltage gain variation with temperature referenced to 25 °C	$V_{DTMF} = 4 \text{ mV (RMS)}$ ; $T_{amb} = -25 \text{ to } +75 \text{ }^\circ\text{C}$	–	$\pm 0.5$	–	dB
$\Delta G_{vtxf}$	voltage gain variation with frequency referenced to 1 kHz	$V_{DTMF} = 4 \text{ mV (RMS)}$ ; $f = 300 \text{ to } 3400 \text{ Hz}$	–	$\pm 0.5$	–	dB
$G_{vtx}$	voltage gain from pin DTMF to QRP	MUTE = HIGH; $V_{line} = 80 \text{ mV (RMS)}$ ; $R_{GAR} = 90.9 \text{ k}\Omega$ ; $R_{QRP} = 150 \text{ }\Omega$	–	–19	–	dB
<b>Automatic gain control (AGC); controlling the gain from LN to QRP, QRM and the gain from MICP, MICM to LN</b>						
$\Delta G_{trx}$	gain control range for microphone and receiving amplifiers with respect to $I_{line} = 20 \text{ mA}$	$I_{line} = 85 \text{ mA}$ ; $R_{AGC} = 100 \text{ k}\Omega$	5	6	7	dB
$I_{line(h)}$	highest line current for maximum gain	$R_{AGC} = 100 \text{ k}\Omega$	–	28	–	mA
$I_{line(l)}$	lowest line current for minimum gain	$R_{AGC} = 100 \text{ k}\Omega$	–	66	–	mA
$\Delta G_{trx}$	change of gain when varying $I_{line}$ from 20 mA to 40 mA	$R_{AGC} = 100 \text{ k}\Omega$	1	1.5	2	dB

## Speech and listening-in IC

## TEA1096; TEA1096A

SYMBOL	PARAMETER	CONDITIONS	MIN.	TYP.	MAX.	UNIT
<b>Loudspeaker amplifier (LSI and QLS)</b>						
$ Z_i $	input impedance between pins LSI and $V_{EE}$		8	10	12	$k\Omega$
$G_{vix}$	voltage gain from pin LSI to QLS	$V_{LSI} = 10 \text{ mV (RMS)}$	34	35.5	37	dB
$\Delta G_{vixT}$	voltage gain variation with temperature referenced to 25 °C	$T_{amb} = -25 \text{ to } +75 \text{ °C}$	–	$\pm 0.5$	–	dB
$\Delta G_{vixf}$	voltage gain variation with frequency referenced to 1 kHz	$f = 300 \text{ to } 3400 \text{ Hz}$	–	$\pm 0.5$	–	dB
$V_{QLS(p-p)}$	output voltage between pins QLS and $V_{EE}$ (peak-to-peak value)	$V_{LSI} = 18 \text{ mV};$ $I_{line} = 16 \text{ mA}$	1.2	1.45	–	V
		$V_{LSI} = 18 \text{ mV};$ $I_{line} = 20 \text{ mA}$	2.5	2.9	–	V
$V_{nolx(rms)}$	noise output voltage at pin LN (RMS value)	pin LSI open-circuit; Psophometrically weighted (P53 curve)	–	200	–	$\mu\text{V}$
<b>Dynamic limiter for the loudspeaker amplifier (DLL/DIL); related to the loudspeaker amplifier clipping detector</b>						
THD	total harmonic distortion	$V_{LSI} = 18 \text{ mV} + 0 \text{ dB};$ $I_{line} = 30 \text{ mA}$	–	2	5	%
$t_{att}$	attack time when $V_{LSI}$ jumps from 18 mV to 18 mV + 0 dB	$I_{line} = 30 \text{ mA};$ $C_{DLL} = 470 \text{ nF}$	–	1.5	5	ms
$t_{rel}$	release time when $V_{LSI}$ drops from 18 mV + 0 dB to 18 mV	$I_{line} = 30 \text{ mA};$ $C_{DLL} = 470 \text{ nF}$	30	60	–	ms
<b>Dynamic limiter for the loudspeaker amplifier (DLL/DIL); related to the <math>V_{BB}</math> threshold detector</b>						
$V_{BB(th)}$	$V_{BB}$ limiter threshold detector level		–	2.8	–	V
$t_{att}$	attack time when $V_{BB}$ jumps below $V_{BB(th)}$	$C_{DLL} = 470 \text{ nF}$	–	1	–	ms
<b>Volume control for the loudspeaker amplifier (VCI) (TEA1096A only); related to the loudspeaker amplifier volume control</b>						
$ Z_i $	input impedance		–	1	–	$M\Omega$
$V_{VCImin}$	minimum DC level on pin VCI for 0 dB control on loudspeaker amplifier	$I_{line} = 30 \text{ mA};$ $V_{LSI} = 10 \text{ mV (RMS)}$	–	2.8	–	V
$V_{VCI}$	DC level on pin VCI for –6 dB control on loudspeaker amplifier	$I_{line} = 30 \text{ mA};$ $V_{LSI} = 10 \text{ mV (RMS)}$	–	1.63	–	V



## Speech and listening-in IC

## TEA1096; TEA1096A

SYMBOL	PARAMETER	CONDITIONS	MIN.	TYP.	MAX.	UNIT
<b>Power-down input (PD)</b>						
$V_{IL}$	LOW level input voltage		–	–	0.5	V
$V_{IH}$	HIGH level input voltage		1.5	–	$V_{DD} + 0.4$	V
$I_{PD}$	input current in power-down condition	PD = HIGH	–	6	10	$\mu\text{A}$
<b>Mute input (MUTE)</b>						
$V_{IL}$	LOW level input voltage		–	–	0.3	V
$V_{IH}$	HIGH level input voltage		1.5	–	$V_{DD} + 0.4$	V
$I_{MUTE}$	input current	MUTE = HIGH	–	15	20	$\mu\text{A}$
<b>Microphone mute input (DLS/MMUTE)</b>						
$V_{IL}$	LOW level input voltage		–	–	0.3	V
$I_{\text{sink(DLS)}}$	sink current	$\overline{\text{DLS/MMUTE}} = \text{LOW}$	–	60	100	$\mu\text{A}$
$t_{\text{rel}}$	release time after a LOW level on pin DLS/MMUTE	$C_{DLS} = 470 \text{ nF}$	–	15	–	ms
$\Delta G_{\text{txm}}$	gain reduction when DLS/MMUTE is short-circuited to $V_{EE}$	$\overline{\text{DLS/MMUTE}} = \text{LOW}$	60	80	–	dB
<b>Disable input for loudspeaker amplifier (DLL/DIL)</b>						
$V_{IL}$	LOW level input voltage		–	–	0.25	V
$I_{\text{sink(DLL/DIL)}}$	sink current	DLL/DIL = LOW	–	75	120	$\mu\text{A}$
$t_{\text{rel}}$	release time after a LOW level on pin DLL/DIL	$I_{\text{line}} = 30 \text{ mA};$ $C_{DDL} = 470 \text{ nF}$	–	10	–	ms
$\Delta G_{\text{lm}}$	gain reduction when DLL is short-circuited to $V_{EE}$	DLL/DIL = LOW	60	80	–	dB

**Notes**

1. This gives the current available for receiving, listening-in and peripherals at this line current.
2. Both gains, microphone and sending DTMF, are determined in the same way by the resistor  $R_{GAS}$ .

**HANDLING**

Inputs and outputs are protected against electrostatic discharge in normal handling. However, to be totally safe, it is desirable to take normal precautions appropriate to handling MOS devices.

Speech and listening-in IC

TEA1096; TEA1096A

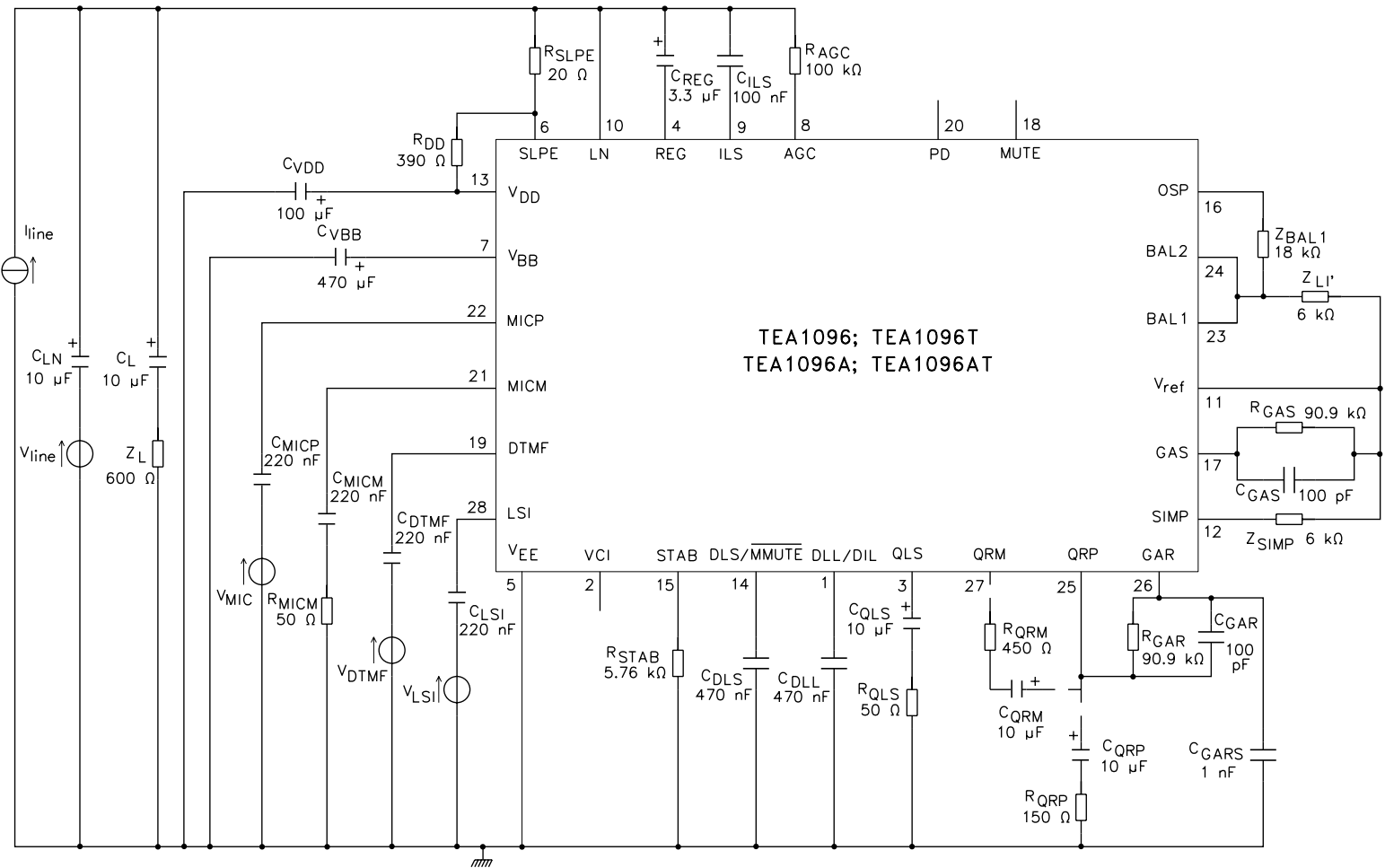

MKA871

Fig.22 Test diagram.

Speech and listening-in IC

TEA1096; TEA1096A

APPLICATION INFORMATION

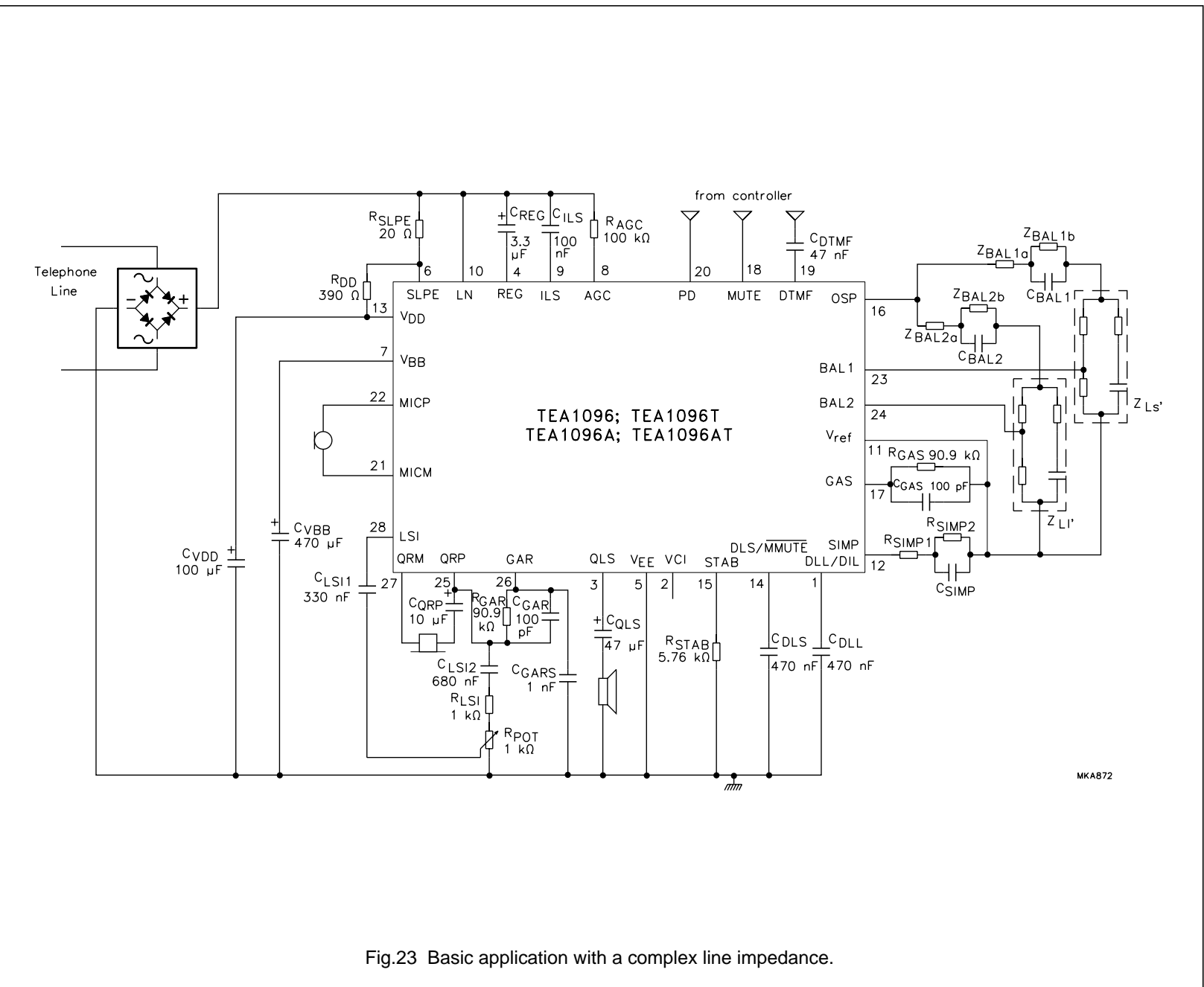
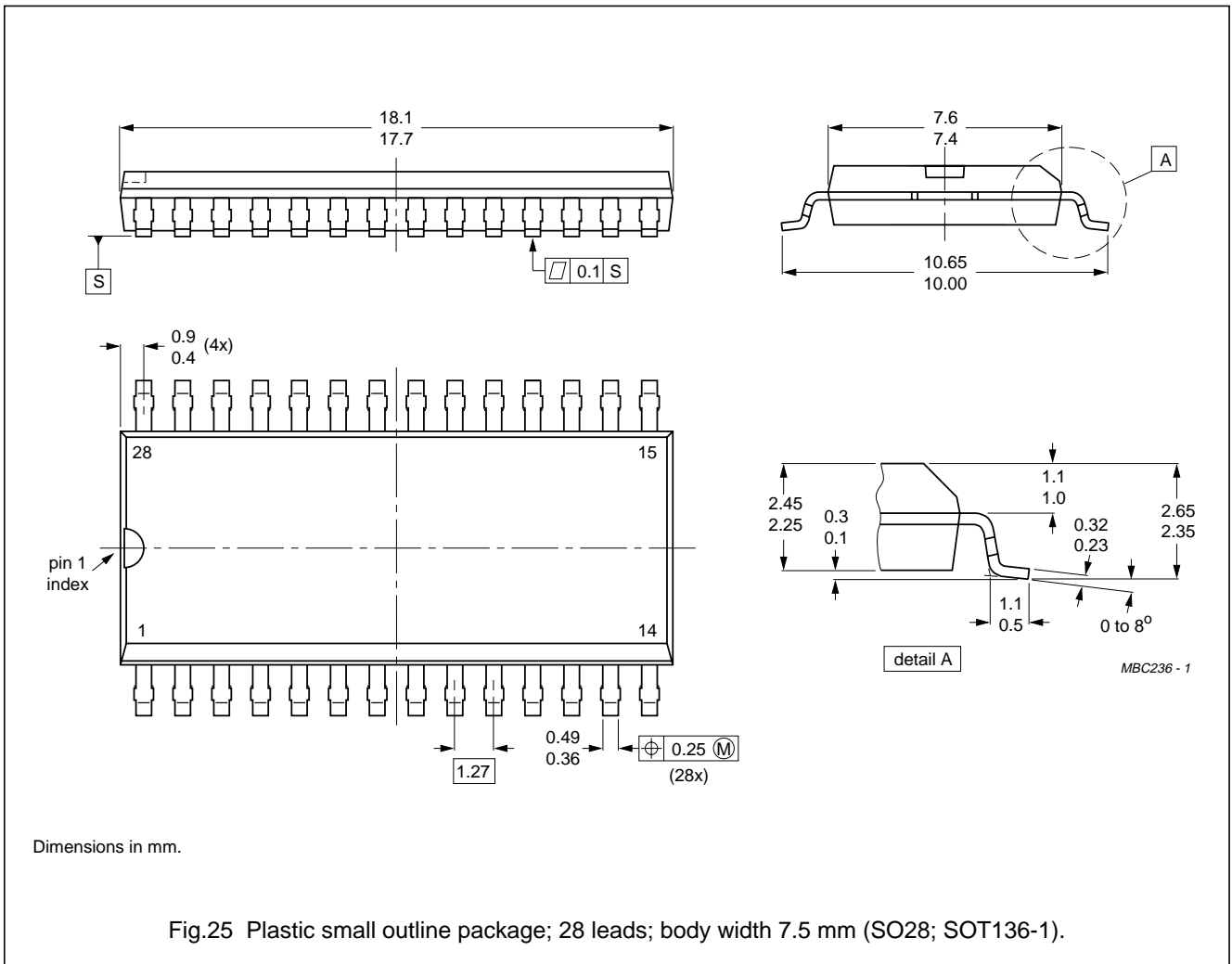

Fig.23 Basic application with a complex line impedance.



Speech and listening-in IC

TEA1096; TEA1096A



---

## Speech and listening-in IC

## TEA1096; TEA1096A

---

### SOLDERING

#### Plastic dual in-line packages

BY DIP OR WAVE

The maximum permissible temperature of the solder is 260 °C; this temperature must not be in contact with the joint for more than 5 s. The total contact time of successive solder waves must not exceed 5 s.

The device may be mounted up to the seating plane, but the temperature of the plastic body must not exceed the specified storage maximum. If the printed-circuit board has been pre-heated, forced cooling may be necessary immediately after soldering to keep the temperature within the permissible limit.

#### REPAIRING SOLDERED JOINTS

Apply a low voltage soldering iron below the seating plane (or not more than 2 mm above it). If its temperature is below 300 °C, it must not be in contact for more than 10 s; if between 300 and 400 °C, for not more than 5 s.

#### Plastic small outline packages

BY WAVE

During placement and before soldering, the component must be fixed with a droplet of adhesive. After curing the adhesive, the component can be soldered. The adhesive can be applied by screen printing, pin transfer or syringe dispensing.

Maximum permissible solder temperature is 260 °C, and maximum duration of package immersion in solder bath is 10 s, if allowed to cool to less than 150 °C within 6 s. Typical dwell time is 4 s at 250 °C.

A modified wave soldering technique is recommended using two solder waves (dual-wave), in which a turbulent wave with high upward pressure is followed by a smooth laminar wave. Using a mildly-activated flux eliminates the need for removal of corrosive residues in most applications.

#### BY SOLDER PASTE REFLOW

Reflow soldering requires the solder paste (a suspension of fine solder particles, flux and binding agent) to be applied to the substrate by screen printing, stencilling or pressure-syringe dispensing before device placement.

Several techniques exist for reflowing; for example, thermal conduction by heated belt, infrared, and vapour-phase reflow. Dwell times vary between 50 and 300 s according to method. Typical reflow temperatures range from 215 to 250 °C.

Preheating is necessary to dry the paste and evaporate the binding agent. Preheating duration: 45 min at 45 °C.

#### REPAIRING SOLDERED JOINTS (BY HAND-HELD SOLDERING IRON OR PULSE-HEATED SOLDER TOOL)

Fix the component by first soldering two, diagonally opposite, end pins. Apply the heating tool to the flat part of the pin only. Contact time must be limited to 10 s at up to 300 °C. When using proper tools, all other pins can be soldered in one operation within 2 to 5 s at between 270 and 320 °C. (Pulse-heated soldering is not recommended for SO packages.)

For pulse-heated solder tool (resistance) soldering of VSO packages, solder is applied to the substrate by dipping or by an extra thick tin/lead plating before package placement.

## Speech and listening-in IC

## TEA1096; TEA1096A

**DEFINITIONS**

<b>Data sheet status</b>	
Objective specification	This data sheet contains target or goal specifications for product development.
Preliminary specification	This data sheet contains preliminary data; supplementary data may be published later.
Product specification	This data sheet contains final product specifications.
<b>Limiting values</b>	
Limiting values given are in accordance with the Absolute Maximum Rating System (IEC 134). Stress above one or more of the limiting values may cause permanent damage to the device. These are stress ratings only and operation of the device at these or at any other conditions above those given in the Characteristics sections of the specification is not implied. Exposure to limiting values for extended periods may affect device reliability.	
<b>Application information</b>	
Where application information is given, it is advisory and does not form part of the specification.	

**LIFE SUPPORT APPLICATIONS**

These products are not designed for use in life support appliances, devices, or systems where malfunction of these products can reasonably be expected to result in personal injury. Philips customers using or selling these products for use in such applications do so at their own risk and agree to fully indemnify Philips for any damages resulting from such improper use or sale.

## Philips Semiconductors – a worldwide company

**Argentina:** IEROD, Av. Juramento 1992 - 14.b, (1428)  
BUENOS AIRES, Tel. (541)786 7633, Fax. (541)786 9367

**Australia:** 34 Waterloo Road, NORTH RYDE, NSW 2113,  
Tel. (02)805 4455, Fax. (02)805 4466

**Austria:** Triester Str. 64, A-1101 WIEN, P.O. Box 213,  
Tel. (01)60 101-1236, Fax. (01)60 101-1211

**Belgium:** Postbus 90050, 5600 PB EINDHOVEN, The Netherlands,  
Tel. (31)40 783 749, Fax. (31)40 788 399

**Brazil:** Rua do Rocio 220 - 5<sup>th</sup> floor, Suite 51,  
CEP: 04552-903-SÃO PAULO-SP, Brazil.  
P.O. Box 7383 (01064-970).

Tel. (011)821-2333, Fax. (011)829-1849

**Canada:** PHILIPS SEMICONDUCTORS/COMPONENTS:  
Tel. (800) 234-7381, Fax. (708) 296-8556

**Chile:** Av. Santa Maria 0760, SANTIAGO,  
Tel. (02)773 816, Fax. (02)777 6730

**Colombia:** IPRELENZO LTDA, Carrera 21 No. 56-17,  
77621 BOGOTA, Tel. (571)249 7624/(571)217 4609,  
Fax. (571)217 4549

**Denmark:** Prags Boulevard 80, PB 1919, DK-2300 COPENHAGEN S,  
Tel. (032)88 2636, Fax. (031)57 1949

**Finland:** Sinikalliontie 3, FIN-02630 ESPOO,  
Tel. (9)0-50261, Fax. (9)0-520971

**France:** 4 Rue du Port-aux-Vins, BP317,  
92156 SURESNES Cedex,  
Tel. (01)4099 6161, Fax. (01)4099 6427

**Germany:** P.O. Box 10 63 23, 20043 HAMBURG,  
Tel. (040)3296-0, Fax. (040)3296 213.

**Greece:** No. 15, 25th March Street, GR 17778 TAVROS,  
Tel. (01)4894 339/4894 911, Fax. (01)4814 240

**Hong Kong:** PHILIPS HONG KONG Ltd., 6/F Philips Ind. Bldg.,  
24-28 Kung Yip St., KWAI CHUNG, N.T.,  
Tel. (852)424 5121, Fax. (852)428 6729

**India:** Philips INDIA Ltd, Shivsagar Estate, A Block,  
Dr. Annie Besant Rd. Worli, Bombay 400 018  
Tel. (022)4938 541, Fax. (022)4938 722

**Indonesia:** Philips House, Jalan H.R. Rasuna Said Kav. 3-4,  
P.O. Box 4252, JAKARTA 12950,  
Tel. (021)5201 122, Fax. (021)5205 189

**Ireland:** Newstead, Clonskeagh, DUBLIN 14,  
Tel. (01)640 000, Fax. (01)640 200

**Italy:** PHILIPS SEMICONDUCTORS S.r.l.,  
Piazza IV Novembre 3, 20124 MILANO,  
Tel. (0039)2 6752 2531, Fax. (0039)2 6752 2557

**Japan:** Philips Bldg 13-37, Kohnan2-chome, Minato-ku, TOKYO 108,  
Tel. (03)3740 5028, Fax. (03)3740 0580

**Korea:** (Republic of) Philips House, 260-199 Itaewon-dong,  
Yongsan-ku, SEOUL, Tel. (02)794-5011, Fax. (02)798-8022

**Malaysia:** No. 76 Jalan Universiti, 46200 PETALING JAYA,  
SELANGOR, Tel. (03)750 5214, Fax. (03)757 4880

**Mexico:** 5900 Gateway East, Suite 200, EL PASO, TX 79905,  
Tel. 9-5(800)234-7381, Fax. (708)296-8556

**Netherlands:** Postbus 90050, 5600 PB EINDHOVEN, Bldg. VB  
Tel. (040)783749, Fax. (040)788399

**New Zealand:** 2 Wagener Place, C.P.O. Box 1041, AUCKLAND,  
Tel. (09)849-4160, Fax. (09)849-7811

**Norway:** Box 1, Manglerud 0612, OSLO,  
Tel. (022)74 8000, Fax. (022)74 8341

**Pakistan:** Philips Electrical Industries of Pakistan Ltd.,  
Exchange Bldg. ST-2/A, Block 9, KDA Scheme 5, Clifton,  
KARACHI 75600, Tel. (021)587 4641-49,  
Fax. (021)577035/5874546.

**Philippines:** PHILIPS SEMICONDUCTORS PHILIPPINES Inc,  
196 Valero St. Salcedo Village, P.O. Box 2108 MCC, MAKATI,  
Metro MANILA, Tel. (02)810 0161, Fax. (02)817 3474

**Portugal:** PHILIPS PORTUGUESA, S.A.,  
Rua dr. António Loureiro Borges 5, Arquiparque - Miraflores,  
Apartado 300, 2795 LINDA-A-VELHA,  
Tel. (01)4163160/4163333, Fax. (01)4163174/4163366.

**Singapore:** Lorong 1, Toa Payoh, SINGAPORE 1231,  
Tel. (65)350 2000, Fax. (65)251 6500

**South Africa:** S.A. PHILIPS Pty Ltd.,  
195-215 Main Road Martindale, 2092 JOHANNESBURG,  
P.O. Box 7430 Johannesburg 2000,  
Tel. (011)470-5911, Fax. (011)470-5494.

**Spain:** Balmes 22, 08007 BARCELONA,  
Tel. (03)301 6312, Fax. (03)301 42 43

**Sweden:** Kottbygatan 7, Akalla. S-164 85 STOCKHOLM,  
Tel. (0)8-632 2000, Fax. (0)8-632 2745

**Switzerland:** Allmendstrasse 140, CH-8027 ZÜRICH,  
Tel. (01)488 2211, Fax. (01)481 77 30

**Taiwan:** PHILIPS TAIWAN Ltd., 23-30F, 66, Chung Hsiao West  
Road, Sec. 1, Taipei, Taiwan ROC, P.O. Box 22978,  
TAIPEI 100, Tel. (02)388 7666, Fax. (02)382 4382.

**Thailand:** PHILIPS ELECTRONICS (THAILAND) Ltd.,  
209/2 Sanpavuth-Bangna Road Prakanong,  
Bangkok 10260, THAILAND,  
Tel. (662)398-0141, Fax. (662)398-3319.

**Turkey:** Talatpasa Cad. No. 5, 80640 GÜLTEPE/ISTANBUL,  
Tel. (0212)279 2770, Fax. (0212)269 3094

**United Kingdom:** Philips Semiconductors LTD.,  
276 Bath road, Hayes, MIDDLESEX UB3 5BX,  
Tel. (081)73050000, Fax. (081)7548421

**United States:** 811 East Arques Avenue, SUNNYVALE,  
CA 94088-3409, Tel. (800)234-7381, Fax. (708)296-8556

**Uruguay:** Coronel Mora 433, MONTEVIDEO,  
Tel. (02)70-4044, Fax. (02)92 0601

**For all other countries apply to:** Philips Semiconductors,  
International Marketing and Sales, Building BE-p,  
P.O. Box 218, 5600 MD, EINDHOVEN, The Netherlands,  
Telex 35000 phtcnl, Fax. +31-40-724825

SCD35 © Philips Electronics N.V. 1994

All rights are reserved. Reproduction in whole or in part is prohibited without the prior written consent of the copyright owner.

The information presented in this document does not form part of any quotation or contract, is believed to be accurate and reliable and may be changed without notice. No liability will be accepted by the publisher for any consequence of its use. Publication thereof does not convey nor imply any license under patent- or other industrial or intellectual property rights.

Printed in The Netherlands

413061/1500/01/pp32  
Document order number:

Date of release: November 1994  
9397 743 10011

# Philips Semiconductors



# PHILIPS