

## Monolithic Integrated Feature Phone Circuit

### Description

The telephone circuit U4089B-M is a linear integrated circuit for use in feature phones, answering machines and fax machines. It contains the speech circuit, sidetone equivalent and ear protection rectifiers. The circuit is line-powered and contains all components necessary for the amplification of signals and adaptation to the line.

An integrated voice switch with loudspeaker amplifier enables loudhearing or hands-free operation. With an anti-feedback function, acoustical feedback during loudhearing can be reduced significantly. The generated supply voltage is suitable for a wide range of peripheral circuits.

### Features

- DC characteristic adjustable
- Transmit and receive gain adjustable
- Symmetrical input of microphone amplifier
- Anti-clipping in transmit direction
- Automatic line-loss compensation
- Built-in ear protection
- DTMF and MUTE input
- Adjustable sidetone suppression independent of sending and receiving amplification
- Integrated amplifier for loudhearing operation
- Anti-clipping for loudspeaker amplifier
- Improved acoustical feedback suppression

- Selectable line impedance
- Voice switch
- Supply voltages for all functional blocks of a subscriber set
- Operation possible from 10-mA line current

### Benefits

- Complete system integration of analog signal processing on one chip
- Very few external components

### Applications

Feature phone, answering machine, fax machine, speaker phone

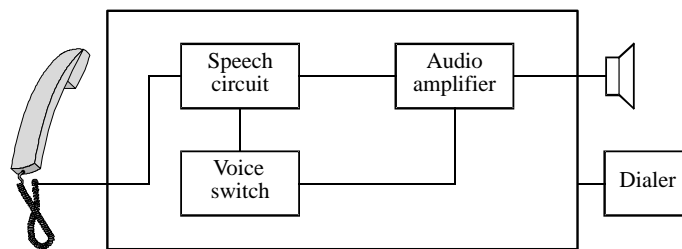

12683

### Ordering Information

Type	Package	Remarks
U4089B-MSD	SDIP30	Tubes
U4089B-MFN	SSO44	Tubes
U4089B-MFNG3	SSO44	Taped and reeled

## Block Diagram

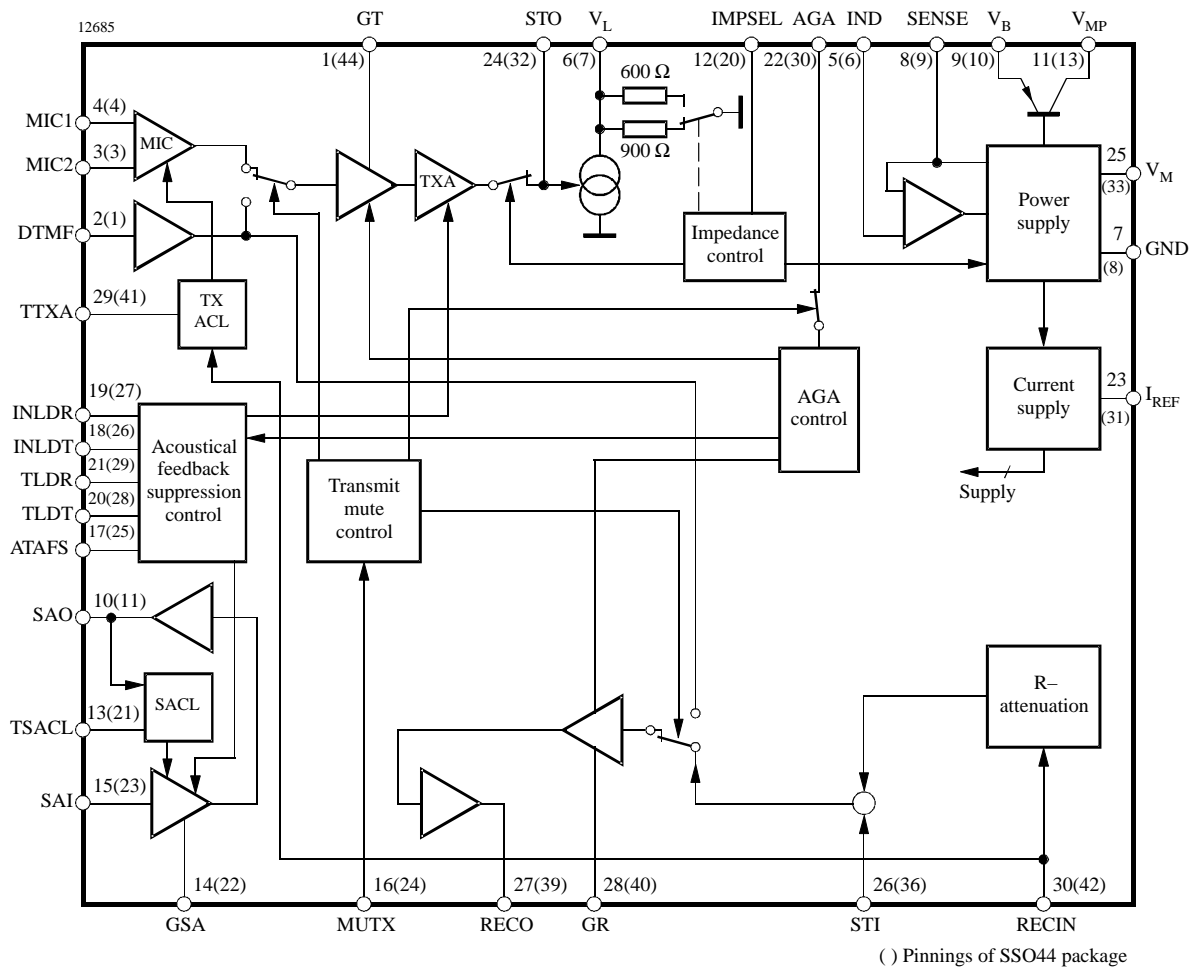

Figure 1. Block diagram

Table 1. Typical values of external components (figure next page)

Name	Value	Name	Value	Name	Value	Name	Value
C <sub>2</sub>	4.7 nF	C <sub>16</sub>	47 μF	R <sub>3</sub>	>68 kΩ	R <sub>16</sub>	1 kΩ
C <sub>3</sub>	10 μF	C <sub>17</sub>	10 μF	R <sub>4</sub>	10 kΩ	R <sub>17</sub>	1.2 kΩ
C <sub>4</sub>	220 μF	C <sub>18</sub>	10 μF	R <sub>6</sub>	62 kΩ	R <sub>18</sub>	30 kΩ
C <sub>5</sub>	47 μF	C <sub>21</sub>	1 μF	R <sub>8</sub>	22 kΩ	R <sub>21</sub>	15 kΩ
C <sub>7</sub>	1 μF	C <sub>23</sub>	6.8 nF	R <sub>9</sub>	330 kΩ	R <sub>22</sub>	330 kΩ
C <sub>8</sub>	100 μF	C <sub>24</sub>	10 nF	R <sub>10</sub>	3 kΩ	R <sub>23</sub>	220 kΩ
C <sub>10</sub>	150 nF	C <sub>25</sub>	100 nF	R <sub>11</sub>	62 kΩ	R <sub>24</sub>	68 kΩ
C <sub>11</sub>	68 nF	C <sub>26</sub>	470 nF	R <sub>12</sub>	30 kΩ	R <sub>25</sub>	2 kΩ
C <sub>12</sub>	33 nF	C <sub>27</sub>	33 nF	R <sub>13</sub>	62 kΩ	R <sub>26</sub>	3.3 kΩ
C <sub>14</sub>	100 nF	C <sub>28</sub>	10 μF	R <sub>14</sub>	120 kΩ	R <sub>29</sub>	1 kΩ
C <sub>15</sub>	1 μF	R <sub>2</sub>	20 kΩ	R <sub>15</sub>	47 kΩ	R <sub>30</sub>	12 kΩ

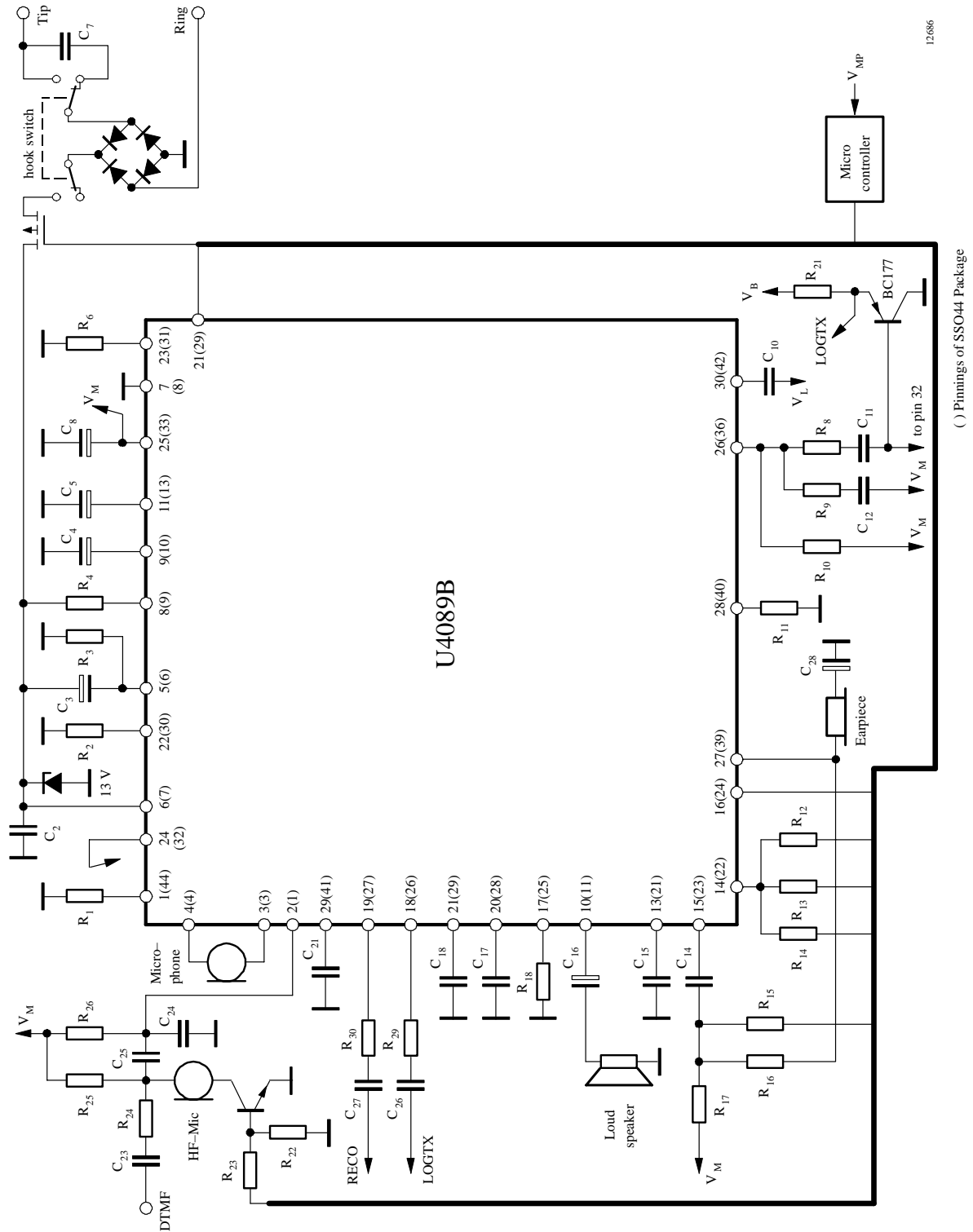

Figure 2. Application for hands-free operation

## Pin Description

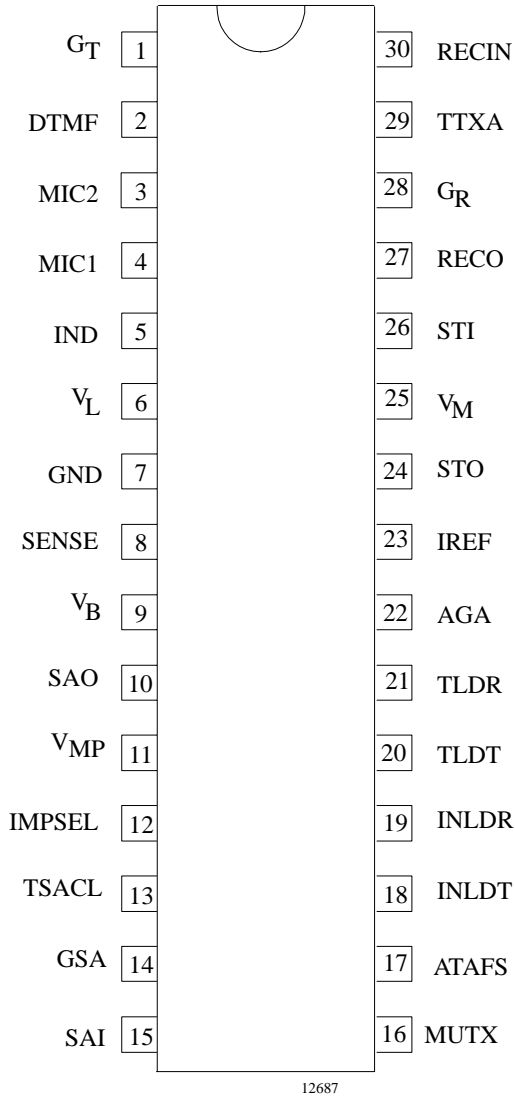

Figure 3. Pinning SDIP30

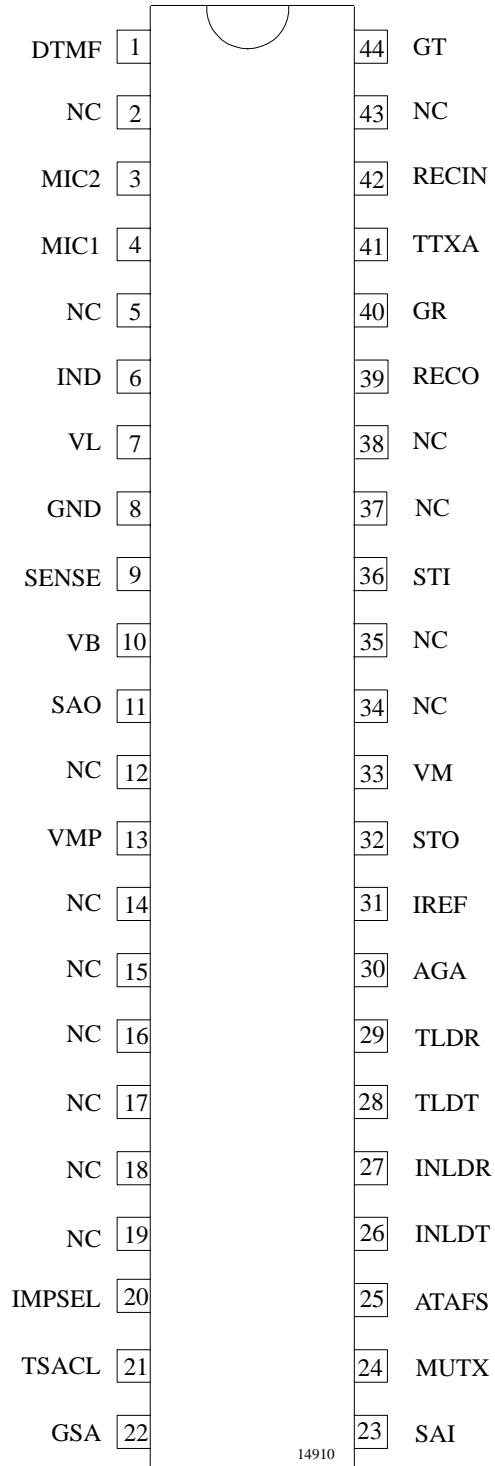

Figure 4. Pinning SSO44

Pin	Symbol	Function
1 (44)	$G_T$	A resistor from this pin to GND sets the amplification of microphone and DTMF signals; the input amplifier can be muted by applying $V_{MP}$ to $G_T$ .
2 (1)	DTMF	Input for DTMF signals. Also used for the answering machine and hands-free input.
3 (3)	MIC 2	Non-inverting input of microphone amplifier
4 (4)	MIC 1	Inverting input of microphone amplifier
5 (6)	IND	The internal equivalent inductance of the circuit is proportional to the value of the capacitor at this pin. A resistor connected to ground may be used to reduce the DC line voltage.
6 (7)	$V_L$	Line voltage
7 (8)	GND	Reference point for DC- and AC-output signals
8 (9)	SENSE	A small resistor (fixed) connected from this pin to $V_L$ sets the slope of the DC characteristic and also affects the line-lengthequalization characteristics and the line current at which the loudspeaker amplifier is switched on.
9 (10)	$V_B$	Unregulated supply voltage for peripheral circuits (voice switch); limited to typically 7 V.
10 (11)	SAO	Output of loudspeaker amplifier
11 (13)	$V_{MP}$	Regulated supply voltage 3.3 V for peripheral circuits. The maximum output current is 2 mA.
12 (20)	IMPSEL	Control input for selection of line impedance 1. 600 $\Omega$ 2. 900 $\Omega$ 3. Mute of second transmit stage (TXA); also used for indication of external supply (answering machine); last chosen impedance is stored
13 (21)	TSACL	Time constant of anti-clipping of speaker amplifier
14 (22)	GSA	Current input for setting the gain of the speaker amplifier. Adjustment characteristic is logarithmical. For $RGSA > 2 \text{ M}\Omega$ , the speaker amplifier is switched off.

Pin	Symbol	Function
15 (23)	SA I	Speaker amplifier input (for loud-speaker, tone ringer and hands-free use)
16 (24)	MUTX	Three-state input of transmit mute: 1) Speech condition; inputs MIC1 / MIC2 active 2) DTMF condition; input DTMF active. A part of the input signal is passed to the receiving amplifier as a confidence signal during dialing. 3) Input DTMF used for answering machine and hands-free use; receive branch is not affected.
17 (25)	ATAFS	Attenuation of acoustical feedback suppression. Maximum attenuation of AFS circuit is set by a resistor at this pin. Without the resistor, AFS is switched off.
18 (26)	INLDT	Input of transmit level detector
19 (27)	INLDR	Input of receive level detector
20 (28)	TLDT	Time constant of transmit level detector
21 (29)	TLDR	Time constant of receive level detector
22 (30)	AGA	Automatic gain adjustment with line current. A resistor connected from this pin to GND sets the starting point. Max. gain change is 6 dB.
23 (31)	IREF	Internal reference current generation; $RREF = 62 \text{ k}\Omega$ ; $IREF = 20 \mu\text{A}$
24 (32)	STO	Side-tone reduction output. Output resistance is approximately 300 $\Omega$ . Maximum load impedance is 10 k $\Omega$ .
25 (33)	$V_M$	Reference node for microphone-earphone and loudspeaker amplifier. Supply for electret microphone ( $I_M \leq 300 \mu\text{A}$ ).
26 (36)	STI	Input for side-tone network
27 (39)	RECO	Output of receiving amplifier
28 (40)	$G_R$	A resistor connected from this pin to GND sets the receiving amplification of the circuit; amplifier RA1 can be muted by applying $V_{MP}$ to $G_R$
29 (41)	TTXA	Time constant of anti-clipping in transmit path
30 (42)	RECIN	Input of receiving path; input impedance is typically 80 k $\Omega$

## DC Line Interface and Supply-Voltage Generation

The DC line interface consists of an electronic inductance and an output stage which charges the capacitor at  $V_B$ . The value of the equivalent inductance is given by:

$$L = R_{SENSE} \times C_{IND} \times (R_{DC} \times R_{30}) / (R_{DC} + R_{30})$$

In order to improve the supply during worst-case operating conditions, PNP current source –  $I_{BOPT}$  –

supplies an extra amount of current to the supply voltages when the NPN in parallel is unable to conduct current.

The U4089B-M contains a series regulator which provides a supply voltage  $V_{MP}$  of 3.3 V at 2 mA suitable for a microprocessor.

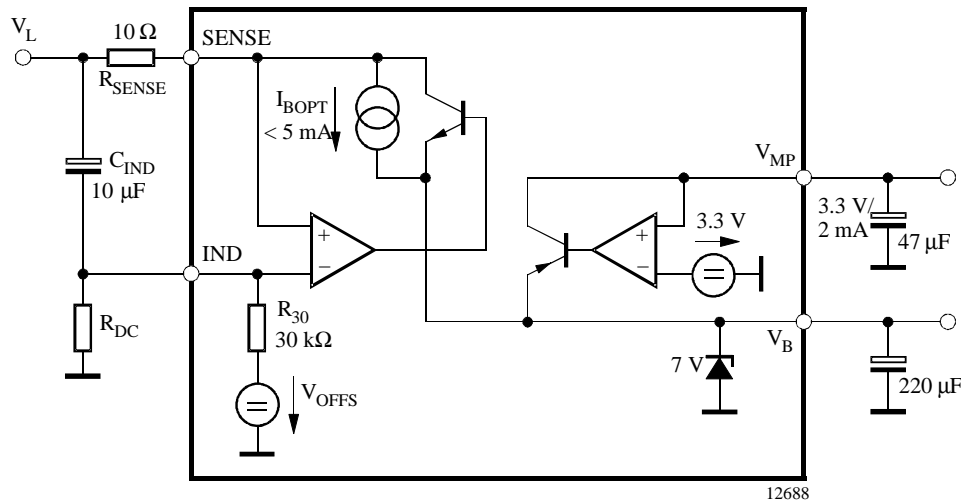

Figure 5. DC line interface with electronic inductance and generation of regulated and unregulated supply

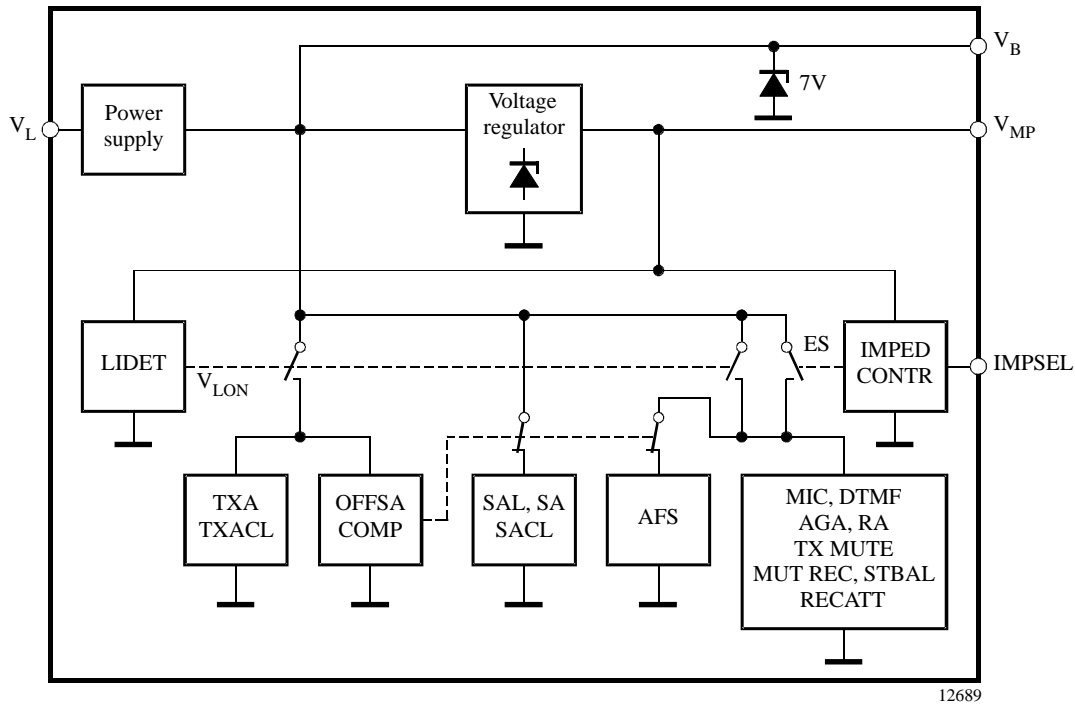

Figure 6. The supply of functional blocks is controlled by input voltages  $V_L$ ,  $V_B$

1. In speech condition, the system is supplied by the line current. If the LIDET-block detects a line voltage above the fixed threshold (1.9 V), the internal signal VLON is activated, thus switching on all blocks of the chip.

For line voltages below 1.9 V, the switches remain in their quiescent state as shown in the diagram.

OFFSACOMP disables the group listening feature (SAI, SA, SACL, AFS) below line currents of approximately 10 mA.

2. Selecting IMPSEL = high impedance activates all switches at the ES line.

### Acoustic Feedback Suppression

Acoustical feedback from the loudspeaker to the handset microphone may cause instability in the system. The U4089B

offers a very efficient feedback suppression circuit which uses a modified voice switch topology. Figure 7 shows the basic system configuration.

Two attenuators (TX ATT and RX ATT) reduce the critical loop gain by introducing an externally adjustable amount of loss either in the transmit or in the receive path. The sliding control in block ATT CONTR determines whether the TX or the RX signal has to be attenuated. The overall loop gain remains constant under all operating conditions.

Selection of the active channel is made by comparison of the logarithmically compressed TX- and RX- envelope curve.

The system configuration for group listening, which is realized in the U4089B-M, is illustrated in figure 8. TXA and SAI represent the two attenuators; the logarithmic envelope detectors are shown in a simplified way (operational amplifiers with two diodes).

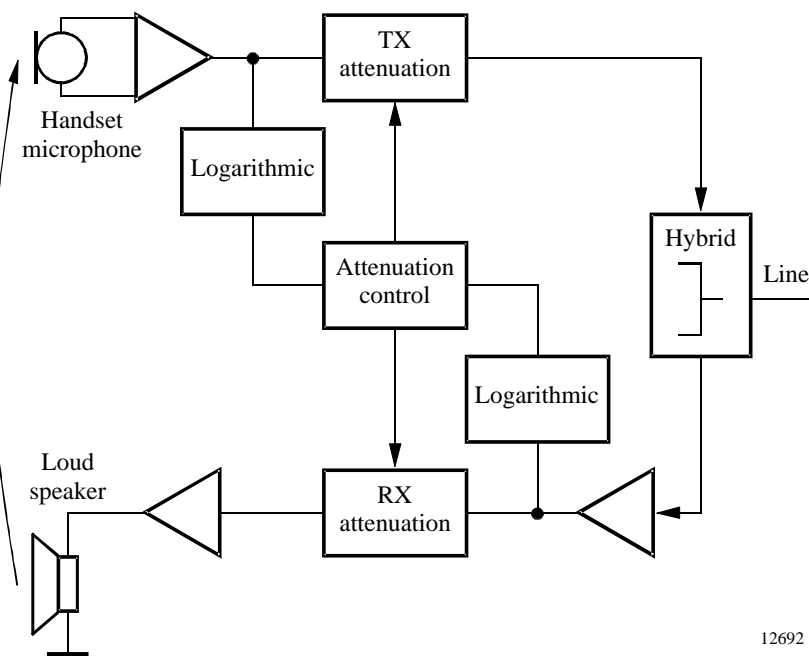
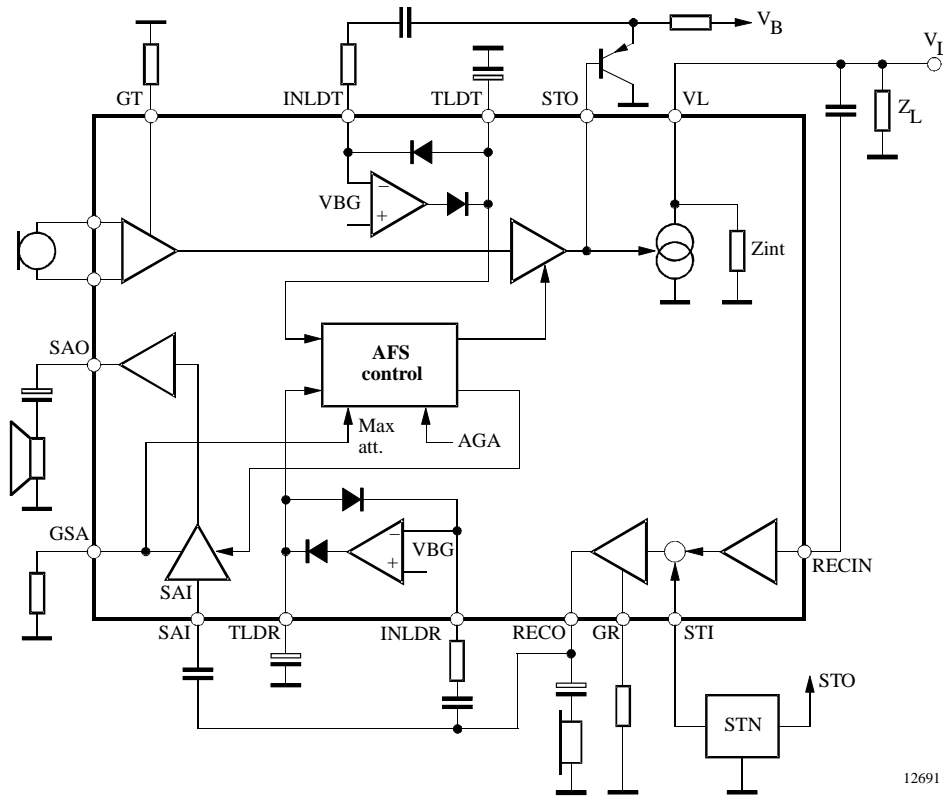
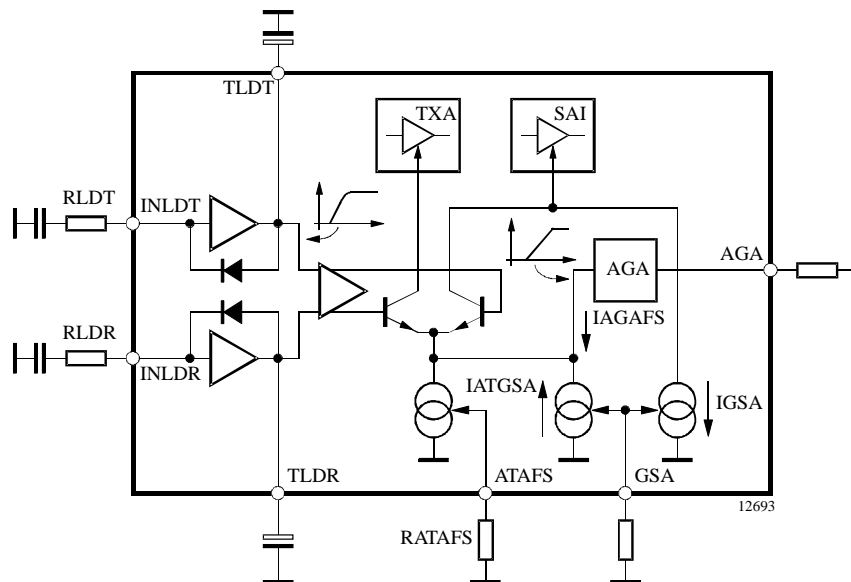

Figure 7. Basic voice-switch system



12691

Figure 8. Integration of the acoustic feedback-suppression circuit into the speech circuit environment



12693

Figure 9. Acoustic feedback suppression by alternative control of transmit- and speaker amplifier gain



A detailed diagram of the AFS (acoustic feedback suppression) is given in figure 9. Receive and transmit signals are first processed by logarithmic rectifiers in order to produce the envelopes of the speech at TLDT and RLDT. After amplification, a decision is made by the differential pair which direction should be transmitted.

The attenuation of the controlled amplifiers TXA and SAI is determined by the emitter current IAT which is comprised of three parts:

- IATAFS sets maximum attenuation
- IATGSA decreases the attenuation when speaker amplifier gain is reduced
- IAGAFS decreases the attenuation according to the loop-gain reduction caused by the AGA-function

$$I_{AT} = I_{ATAFS} - I_{ATGSA} - I_{AGAFS}$$

$$\Delta G = I_{AT} \times 0.67 \text{ dB}/\mu\text{A}$$

Figure 10 illustrates the principal relationship between speaker amplifier gain (GSA) and attenuation of AFS (ATAFS). Both parameters can be adjusted independently, but the internal coupling between them has to be considered. The maximum value to be used of GSA is 36 dB. The shape of the characteristic is moved in the x-direction by adjusting resistor RATAFS, thus changing  $ATAFS_m$ . The actual value of the attenuation ( $ATAFS_a$ ), however, can be determined by reading the value which belongs to the actual gain  $GSA_a$ . If the speaker amplifier gain is reduced, the attenuation of AFS is automatically reduced by the same amount in order to achieve a constant loop gain. Zero attenuation is set for speaker gains  $GSA \leq GSA_0 = 36 \text{ dB} - ATAFS_m$ .

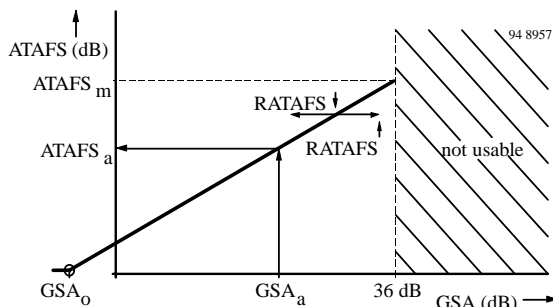

Figure 10. Reducing speaker amplifier gain results in an equal reduction of AFS attenuation

## Operating Range of Speaker Amplifier

The basic behavior is illustrated in figure 11. Actual values of ILON/ILOFF vary slightly with the adjustment of the DC-characteristics and the selection of the internal line impedance.

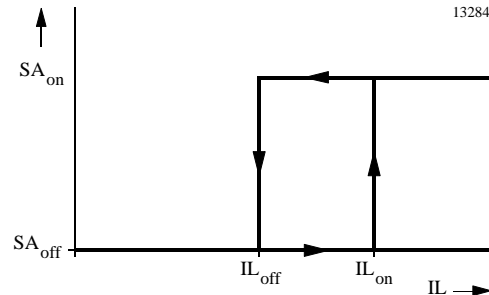
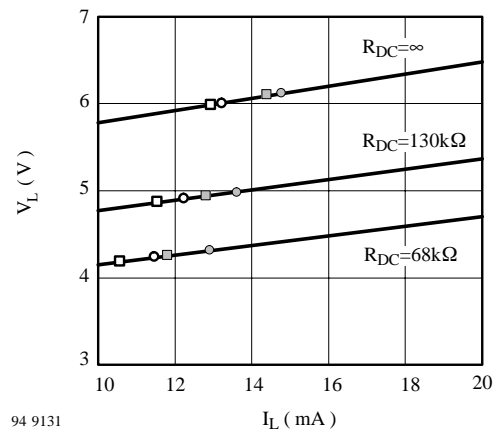

Figure 11. Threshold of speaker amplifier



- = ILON at line impedance = 600  $\Omega$
- = ILOFF at line impedance = 600  $\Omega$
- = ILON at line impedance = 900  $\Omega$
- ◊ = ILOFF at line impedance = 900  $\Omega$

Figure 12. Comparator thresholds depend on DC mask and line impedance

## Absolute Maximum Ratings

Parameters	Symbol	Value	Unit
Line current	$I_L$	140	mA
DC line voltage	$V_L$	12	V
Junction temperature	$T_j$	125	°C
Ambient temperature	$T_{amb}$	-25 to +75	°C
Storage temperature	$T_{stg}$	-55 to +150	°C
Total power dissipation, $T_{amb} = 60^\circ\text{C}$	SDIP30 $P_{tot}$	1	W
	SSO44 $P_{tot}$	0.9	W

## Thermal Resistance

Parameters	Symbol	Value	Unit
Junction ambient	SDIP30 $R_{thJA}$	50	K/W
	SSO44 $R_{thJA}$	70	K/W

## Electrical Characteristics

$f = 1 \text{ kHz}$ ,  $0 \text{ dBm} = 775 \text{ mV}_{rms}$ ,  $I_M = 0.3 \text{ mA}$ ,  $I_{MP} = 2 \text{ mA}$ ,  $RDC = 130 \text{ k}\Omega$ ,  $T_{amb} = 25^\circ\text{C}$ ,  $RGSA = 560 \text{ k}\Omega$ ,  $Z_{ear} = 68 \text{ nF} + 100 \text{ }\Omega$ ,  $Z_M = 68 \text{ nF}$ , Pin 20 open,  $V_{MUTX} = \text{GND}$ , unless otherwise specified.

Parameters	Test Conditions / Pin	Symbol	Min.	Typ.	Max.	Unit	Fig.
<b>DC characteristics</b>							
DC voltage drop over circuit	$I_L = 2 \text{ mA}$ $I_L = 14 \text{ mA}$ $I_L = 60 \text{ mA}$ $I_L = 100 \text{ mA}$	$V_L$	4.6	2.4 5.0 7.5 9.4	5.4 10.0	V	20
<b>Transmission amplifier, <math>I_L = 14 \text{ mA}</math>, <math>V_{MIC} = 2 \text{ mV}</math>, <math>RGT = 27 \text{ k}\Omega</math>, unless otherwise specified</b>							
Adjustment range of transmit gain		$G_T$	40	45	50	dB	23
Transmitting amplification	$RGT = 12 \text{ k}\Omega$ $RGT = 27 \text{ k}\Omega$	$G_T$	47 39.8	48	49 41.8	dB	23
Frequency response	$I_L \geq 14 \text{ mA}$ , $f = 300 \text{ to } 3400 \text{ Hz}$	$\Delta G_T$			$\pm 0.5$	dB	23
Gain change with current	Pin 20 open $I_L = 14 \text{ to } 100 \text{ mA}$	$\Delta G_T$			$\pm 0.5$	dB	23
Gain deviation	$T_{amb} = -10 \text{ to } +60^\circ\text{C}$	$\Delta G_T$			$\pm 0.5$	dB	23
CMRR of microphone amplifier		CMRR	60	80		dB	23
Input resistance of MIC amplifier	$RGT = 12 \text{ k}\Omega$ $RGT = 27 \text{ k}\Omega$	$R_i$	45	50 75	110	$\text{k}\Omega$	23
Distortion at line	$I_L > 14 \text{ mA}$ $V_L = 700 \text{ mV}_{rms}$	$d_t$			2	%	23
Maximum output voltage	$I_L > 19 \text{ mA}$ , $d < 5\%$ $V_{mic} = 25 \text{ mV}$ $CTXA = 1 \text{ }\mu\text{F}$	$V_{Lmax}$	1.8	3	4.2	dBm	23
Noise at line psophometrically weighted	$I_L > 14 \text{ mA}$ $G_T = 48 \text{ dB}$	no		-80	-72	dBmp	23
Anti-clipping attack time	$CTXA = 1 \text{ }\mu\text{F}$ each 3 dB overdrive			0.5		ms	23
release time				9		ms	

## Electrical Characteristics (continued)

Parameters	Test Conditions / Pin	Symbol	Min.	Typ.	Max.	Unit	Fig.
Gain at low operating current	$I_L = 10 \text{ mA}$ $I_{MP} = 1 \text{ mA}$ $RDC = 68 \text{ k}\Omega$ $V_{mic} = 1 \text{ mV}$ $I_M = 300 \mu\text{A}$	$G_T$	40		42.5	dB	23
Distortion at low operating current	$I_L = 10 \text{ mA}$ $I_M = 300 \mu\text{A}$ $I_{MP} = 1 \text{ mA}$ $RDC = 68 \text{ k}\Omega$ $V_{mic} = 10 \text{ mV}$	$d_t$			5	%	23
Line-loss compensation	$I_L = 100 \text{ mA}$ , $RAGA = 20 \text{ k}\Omega$	$\Delta G_{TI}$	-6.4	-5.8	-5.2	dB	23
Mute suppression a) MIC muted (microphone preamplifier)	$I_L \geq 14 \text{ mA}$ Mutx = open	$G_{TM}$	60	80		dB	23
<b>Receiving amplifier, <math>I_L = 14 \text{ mA}</math>, <math>RGR = 62 \text{ k}</math>, unless otherwise specified, <math>V_{GEN} = 300 \text{ mV}</math></b>							
Adjustment range of receiving gain	$I_L \geq 14 \text{ mA}$ , single-ended	$G_R$	-8		+2	dB	23
Receiving amplification	$RGR = 62 \text{ k}\Omega$ $RGR = 22 \text{ k}\Omega$	$G_R$	-7.75	-7 1.5	-6.25	dB	23
Amplification of DTMF signal from DTMF IN to RECO	$I_L \geq 14 \text{ mA}$ $V_{MUTX} = V_{MP}$	$G_{RM}$	1	4	7	dB	23
Frequency response	$I_L > 14 \text{ mA}$ , $f = 300 \text{ to } 3400 \text{ Hz}$	$\Delta G_{RF}$			$\pm 0.5$	dB	23
Gain change with current	$I_L = 14 \text{ to } 100 \text{ mA}$	$\Delta G_R$			$\pm 0.5$	dB	23
Gain deviation	$T_{amb} = -10 \text{ to } +60^\circ\text{C}$	$\Delta G_R$			$\pm 0.5$	dB	23
Ear protection	$I_L \geq 14 \text{ mA}$ $V_{GEN} = 11 V_{rms}$	EP			1.1	$V_{rms}$	23
MUTE suppression DTMF operation	$I_L \geq 14 \text{ mA}$ $V_{MUTX} = V_{MP}$	$\Delta G_R$	60			dB	23
Output voltage $d \leq 2\%$	$I_L = 14 \text{ mA}$ $Z_{ear} = 68 \text{ nF}$		0.5			$V_{rms}$	23
Maximum output current $d \leq 2\%$	$Z_{ear} = 100 \Omega$		4			mA (peak)	23
Receiving noise psophometrically weighted	$Z_{ear} = 68 \text{ nF} + 100 \Omega$ $I_L \geq 14 \text{ mA}$	ni		-80	-77	dBmp	23
Output resistance	Output against GND	$R_o$			10	$\Omega$	23
Line-loss compensation	$RAGA = 20 \text{ k}\Omega$ , $I_L = 100 \text{ mA}$	$\Delta G_{RI}$	-7.0	-6.0	-5.0	dB	23
Gain at low operating current	$I_L = 10 \text{ mA}$ $I_{MP} = 1 \text{ mA}$ $I_M = 300 \mu\text{A}$ $V_{GEN} = 560 \text{ mV}$ $RDC = 68 \text{ k}\Omega$	$G_R$	-8	-7	-6	dB	23
AC impedance		$Z_{imp}$	840	900	960	$\Omega$	23
Distortion at low operating current	$I_L = 10 \text{ mA}$ $I_{MP} = 1 \text{ mA}$ $V_{GEN} = 560 \text{ mV}$ $RDC = 68 \text{ k}\Omega$	$d_R$			5	%	23

## Electrical Characteristics (continued)

Parameters	Test Conditions / Pin	Symbol	Min.	Typ.	Max.	Unit	Fig.
<b>Speaker amplifier</b>							
Minimum line current for operation	No ac signal	$I_{Lmin}$			15	mA	22
Input resistance	Pin 24		14		22	k $\Omega$	23
Gain from SAI to SAO	$V_{SAI} = 3\text{ mV}$ , $I_L = 15\text{ mA}$ , $R_{GSA} = 560\text{ k}\Omega$ $R_{GSA} = 20\text{ k}\Omega$	$G_{SA}$	35.5	36.5 - 3	37.5	dB dB	23
Output power	Load resistance $R_L = 50\ \Omega$ , $d < 5\%$ $V_{SAI} = 20\text{ mV}$ $I_L = 15\text{ mA}$ $I_L = 20\text{ mA}$	$P_{SA}$ $P_{SA}$	3	7 20		mW mW	23
Output noise (input SAI open) psophometrically weighted	$I_L > 15\text{ mA}$	$n_{SA}$			200	$\mu\text{V}_{psoph}$	23
Gain deviation	$I_L = 15\text{ mA}$ $T_{amb} = -10\text{ to }+60^\circ\text{C}$	$\Delta G_{SA}$			$\pm 1$	dB	23
Mute suppression	$I_L = 15\text{ mA}$ , $V_L = 0\text{ dBm}$ , $V_{SAI} = 4\text{ mV}$ Pin 23 open	VSAO			-60	dBm	23
Gain change with current	$I_L = 15\text{ to }100\text{ mA}$	$\Delta G_{SA}$			$\pm 1$	dB	23
Resistor for turning off speaker amplifier	$I_L = 15\text{ to }100\text{ mA}$	$R_{GSA}$	0.8	1.3	2	M $\Omega$	23
Gain change with frequency	$I_L = 15\text{ mA}$ $f = 300\text{ to }3400\text{ Hz}$	$\Delta G_{SA}$			$\pm 0.5$	dB	23
Attack time of anti-clipping	20 dB over drive	$t_r$		5		ms	23
Release time of anti-clipping		$t_f$		80		ms	23
<b>DTMF amplifier Test conditions: <math>I_{MP} = 2\text{ mA}</math>, <math>I_M = 0.3\text{ mA}</math>, <math>V_{MUTX} = V_{MP}</math></b>							
Adjustment range of DTMF gain	$I_L = 15\text{ mA}$ Mute active	$G_D$	40		50	dB	23
DTMF amplification	$I_L = 15\text{ mA}$ , $V_{DTMF} = 8\text{ mV}$ Mute active: $MUTX = V_{MP}$	$G_D$	40.7	41.7	42.7	dB	23
Gain deviation	$I_L = 15\text{ mA}$ $T_{amb} = -10\text{ to }+60^\circ\text{C}$	$G_D$			$\pm 0.5$	dB	23
Input resistance	$R_{GT} = 27\text{ k}\Omega$ , $R_{GT} = 15\text{ k}\Omega$	$R_i$	60 26	180 70	300 130	k $\Omega$	23
Distortion of DTMF signal	$I_L \geq 15\text{ mA}$ $V_L = 0\text{ dBm}$	$d_D$			2	%	23
Gain deviation with current	$I_L = 15\text{ to }100\text{ mA}$	$\Delta G_D$			$\pm 0.5$	dB	23
<b>AFS acousting feedback suppression</b>							
Range of attenuation	$I_L \geq 15\text{ mA}$		0		50	dB	23
Attenuation of transmit gain	$I_L \geq 15\text{ mA}$ , $I_{INLDT} = 0\ \mu\text{A}$ $R_{ATAFS} = 30\text{ k}\Omega$ $I_{INLDR} = 10\ \mu\text{A}$	$\Delta G_T$		45		dB	23

## Electrical Characteristics (continued)

Parameters	Test Conditions / Pin	Symbol	Min.	Typ.	Max.	Unit	Fig.
Attenuation of speaker amplifier	$I_L \geq 15 \text{ mA}$ $I_{INLDP} = 0 \mu$ $R_{ATAFS} = 30 \text{ k}\Omega$ $I_{INLDR} = 10 \mu$	$\Delta G_{SA}$		50		dB	23
AFS disable	$I_L \geq 15 \text{ mA}$	$V_{ATAFS}$	1.5			V	23
<b>Supply voltages, <math>V_{mic} = 25 \text{ mV}</math>, <math>T_{amb} = -10 \text{ to } +60^\circ\text{C}</math></b>							
$V_{MP}$	$I_L = 14 \text{ mA}$ , $RDC = 68 \text{ k}\Omega$ $I_{MP} = 2 \text{ mA}$	$V_{MP}$	3.1	3.3	3.5	V	23
$V_M$	$I_L \geq 14 \text{ mA}$ , $I_M = 300 \mu\text{A}$ $RDC = 130 \text{ k}\Omega$	$V_M$	1.4		3.3	V	23
$V_B$	$I_B = +20 \text{ mA}$ , $I_L = 0 \text{ mA}$	$V_B$		7	7.6	V	23
<b>MUTX input</b>							
Input current	$V_{MUTX} = V_{MP}$ $V_{MUTX} = \text{GND}$	$I_{MUTX}$ $I_{MUTX}$		20 -20	30 -30	$\mu\text{A}$ $\mu\text{A}$	21
Input voltage	Input high	$V_{MUTX}$	$V_{MP} - 0.3 \text{ V}$			V	21
	Input low	$V_{MUTX}$			0.3	V	21

## U4089B-M Control

MUTX	MODE
0 MIC 1/2 transmit enabled receive enable AFS = on AGA = on TXACL = on	Speech
Z DTMF transmit enabled receive enable AFS = on AGA = on TXACL = on	For answering machine
1 DTMF transmit enabled DTMF to receive enable AFS = off AGA = off TXACL = off	DTMF dialling

IMPSEL	MODE
0 Line impedance = 600 $\Omega$ TXA = on ES = off	Speech
0 to Z Line impedance = 600 $\Omega$ TXA = off ES = on	Transmit mute
1 to Z Line impedance = 900 $\Omega$ TXA = off ES = on	Transmit mute
1 Line impedance = 900 $\Omega$ TXA = on ES = off	Speech

Logic-level
0 = < (0.3 V)
Z = > (1 V) < ( $V_{MP} - 1 \text{ V}$ ) or (open input)
1 = > ( $V_{MP} - 0.3 \text{ V}$ )

AFS = Acoustical feedback-suppression control  
 AGA = Automatic gain adjustment  
 TXACL = Transmit anti-clipping control  
 ES = External supply

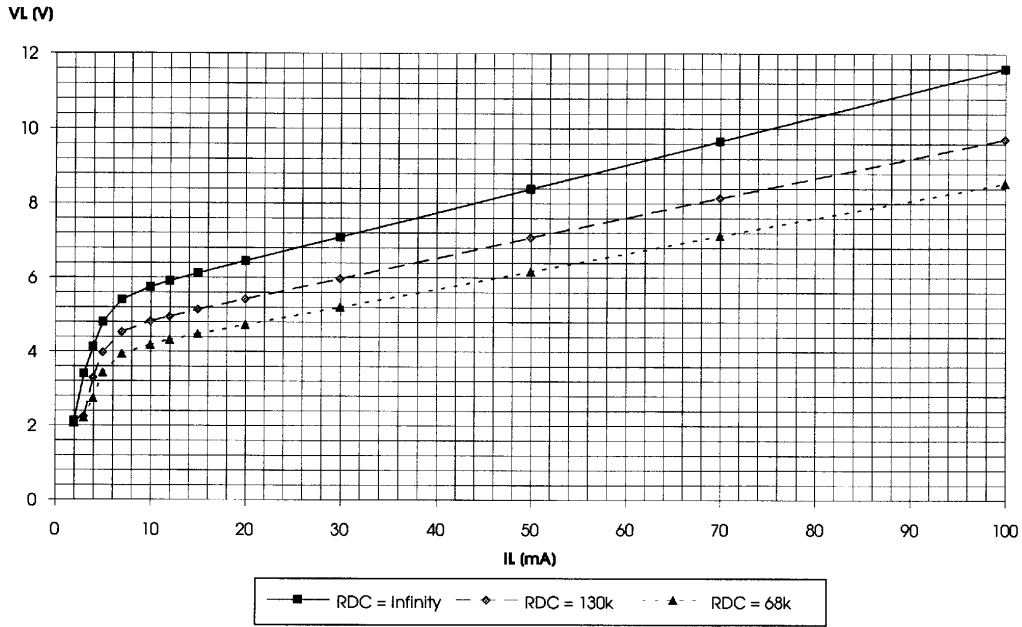

94 8856

Figure 13. Typical DC characteristic

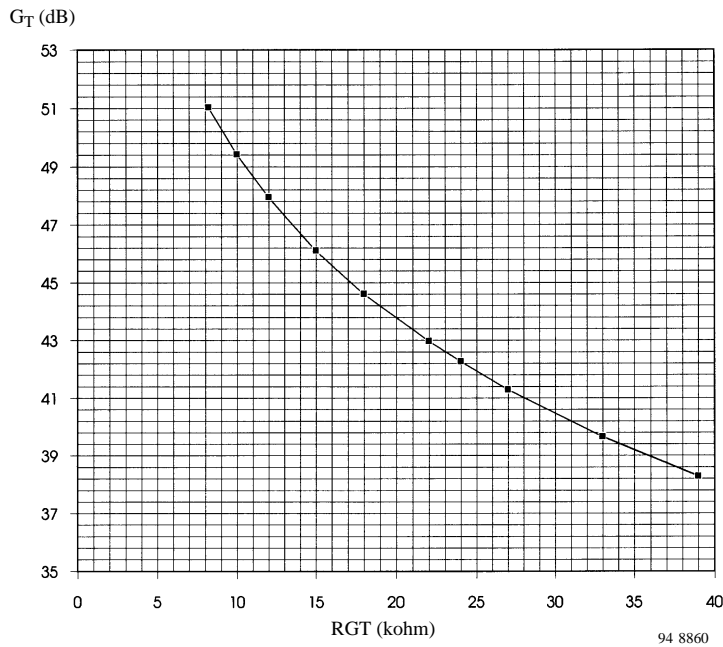

94 8860

Figure 14. Typical adjustment range of the transmit gain

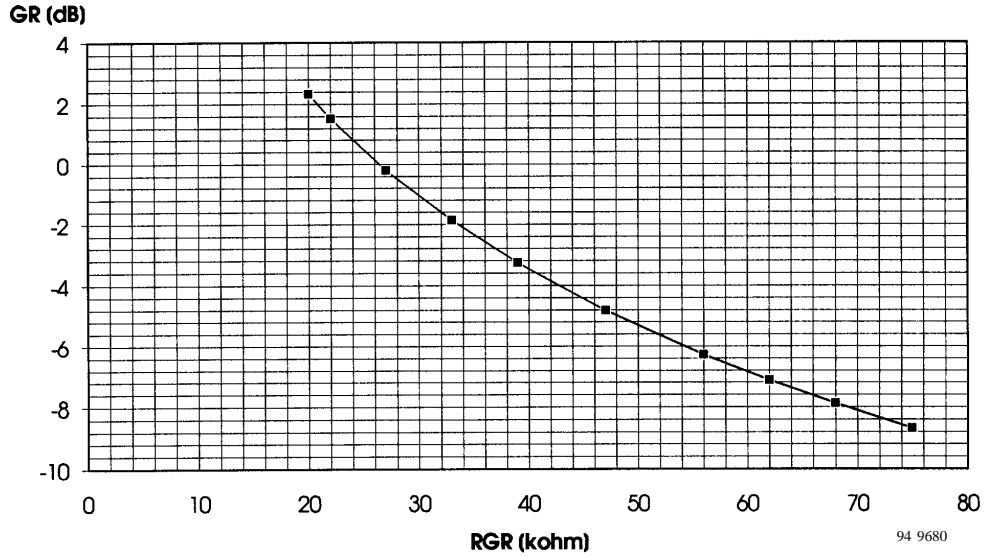

Figure 15. Typical adjustment range of the receive gain

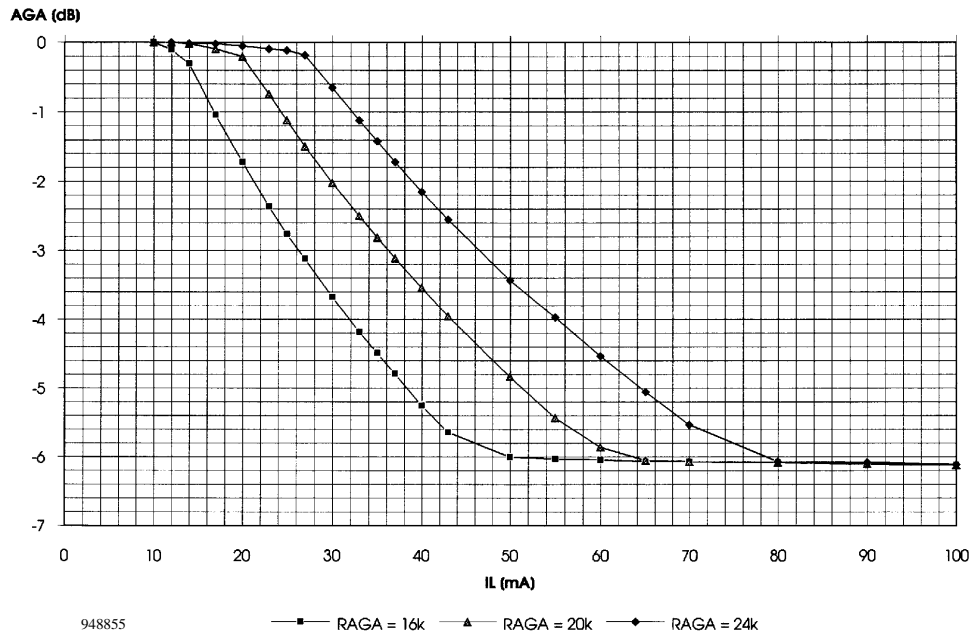

Figure 16. Typical AGA characteristic

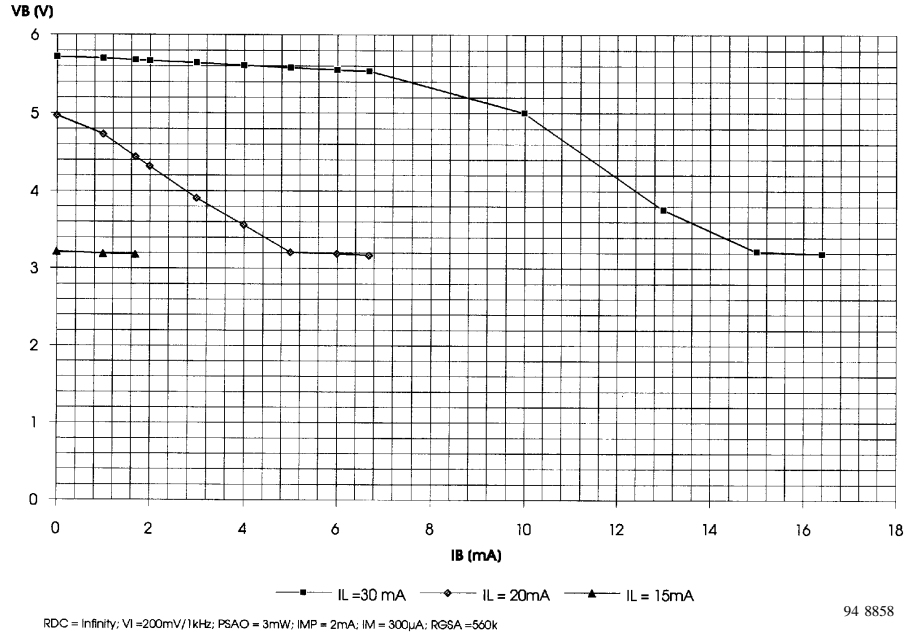

Figure 17. Typical load characteristic of  $V_B$  for a maximum ( $RDC = \infty$ ) DC characteristic and a 3-mW loudspeaker output

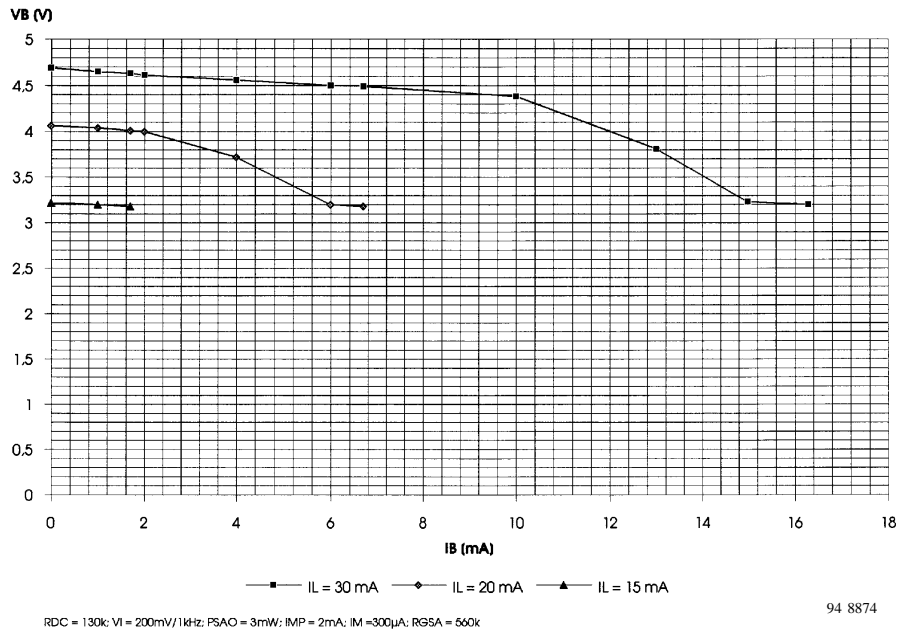

Figure 18. Typical load characteristic of  $V_B$  for a medium DC characteristic ( $RDC = 130$  k $\Omega$ ) and a 3-mW loudspeaker output



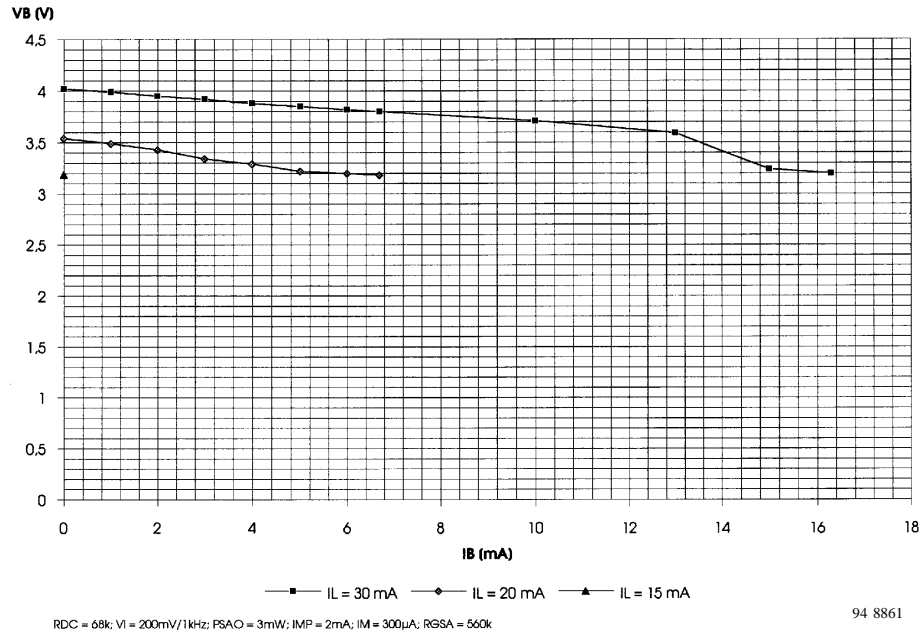

Figure 19. Typical load characteristic of  $V_B$  for a minimum DC characteristic (RDC = 68 k $\Omega$ ) and a 3-mW loudspeaker output

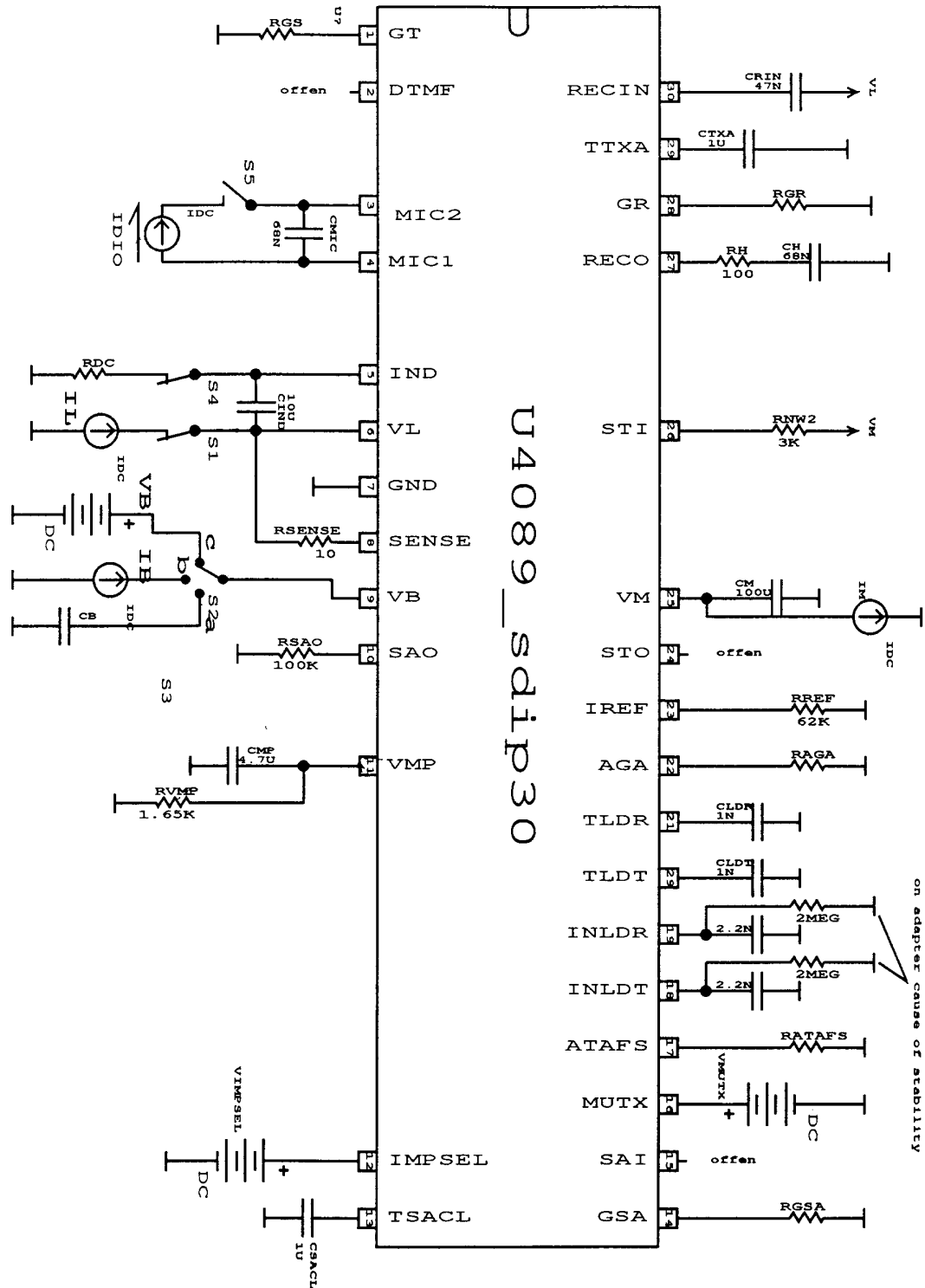

Figure 20. DC voltage absolut

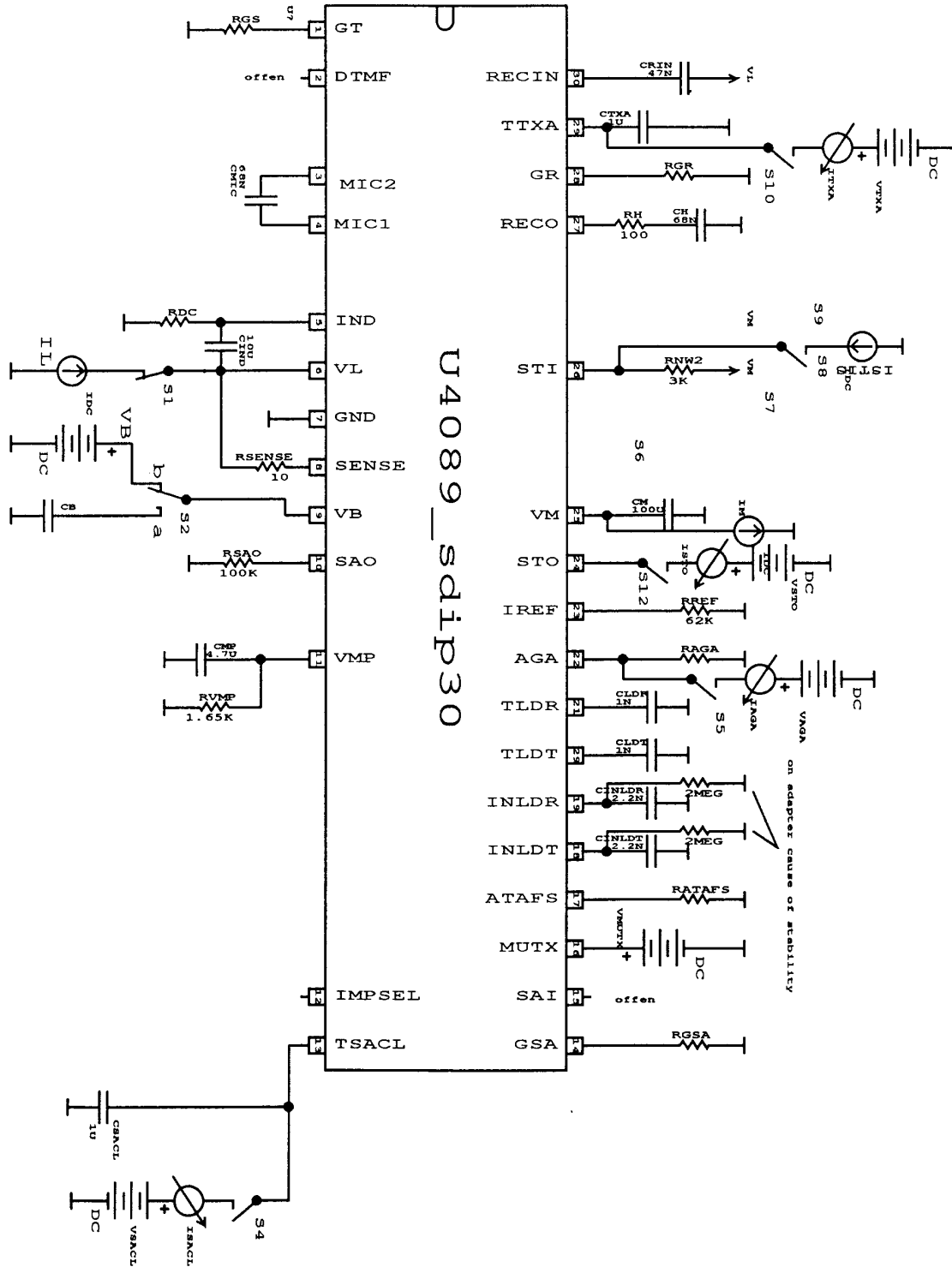

Figure 21. DC voltage current test

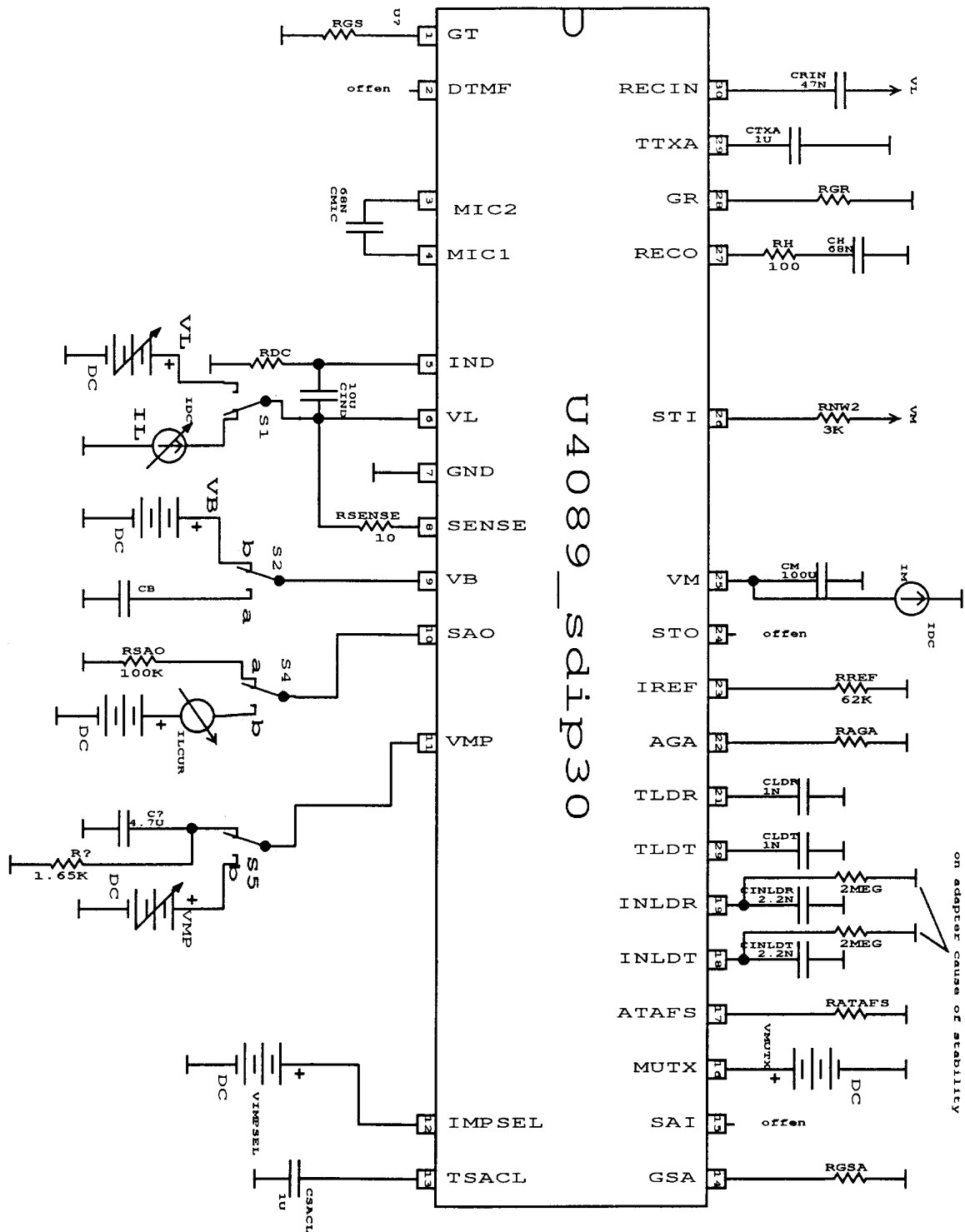

Figure 22. DC ramps

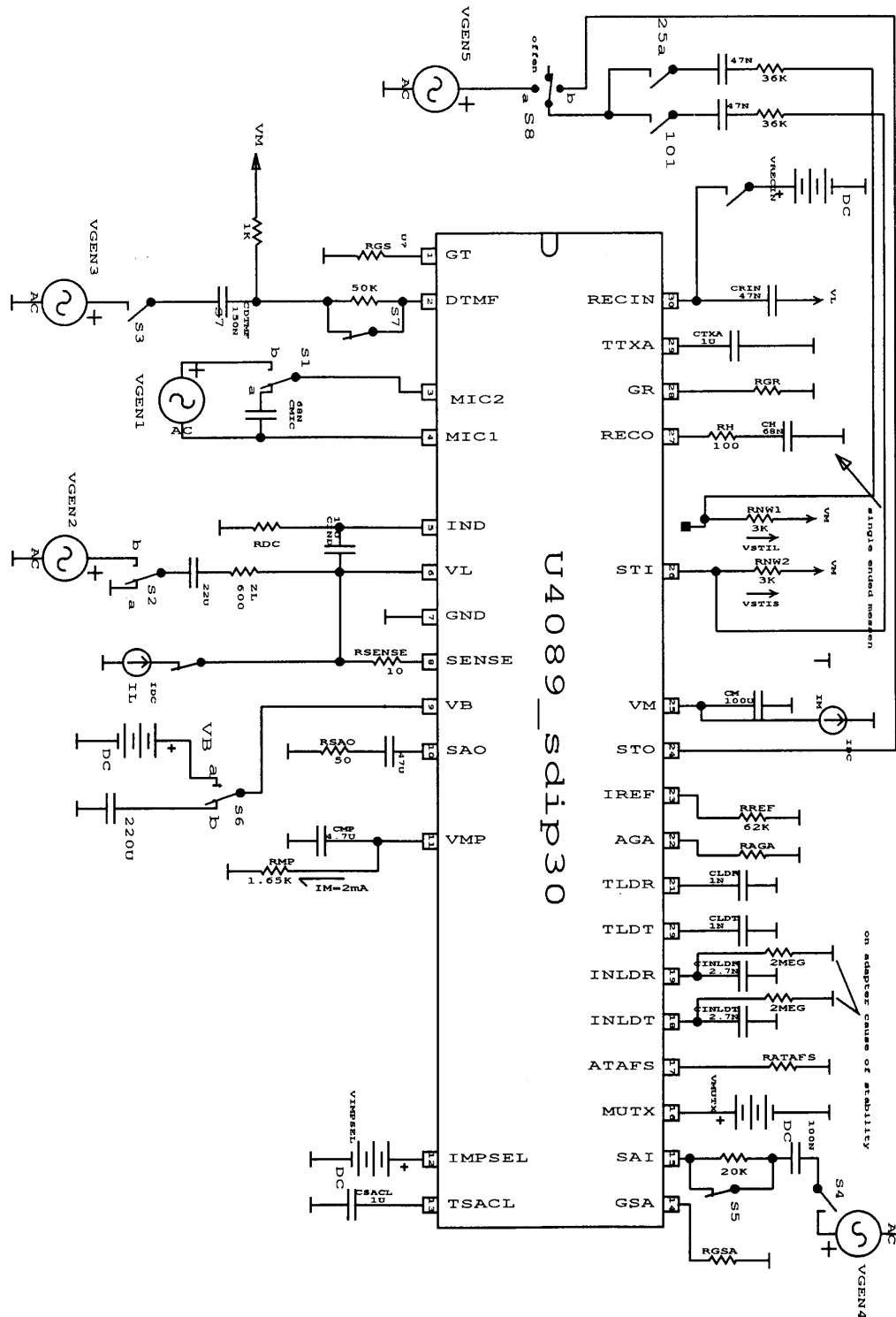
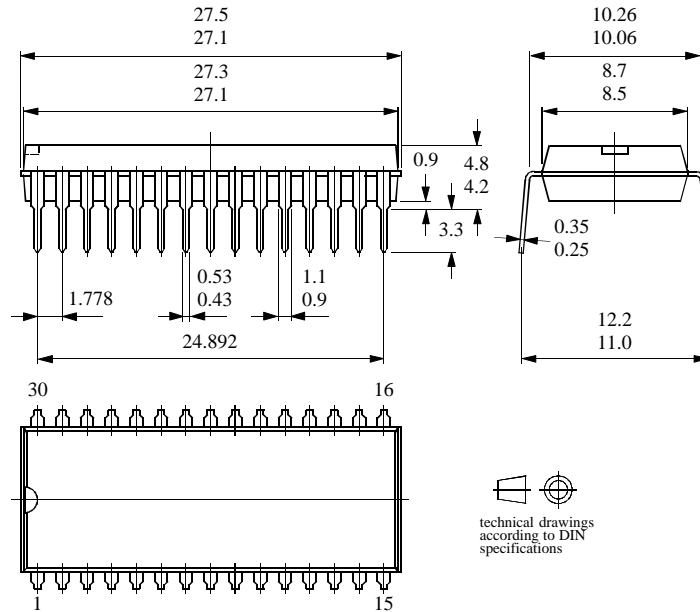

Figure 23. AC tests

## Package Information

### Package SDIP30

Dimensions in mm



13046

### Package SSO44

Dimensions in mm

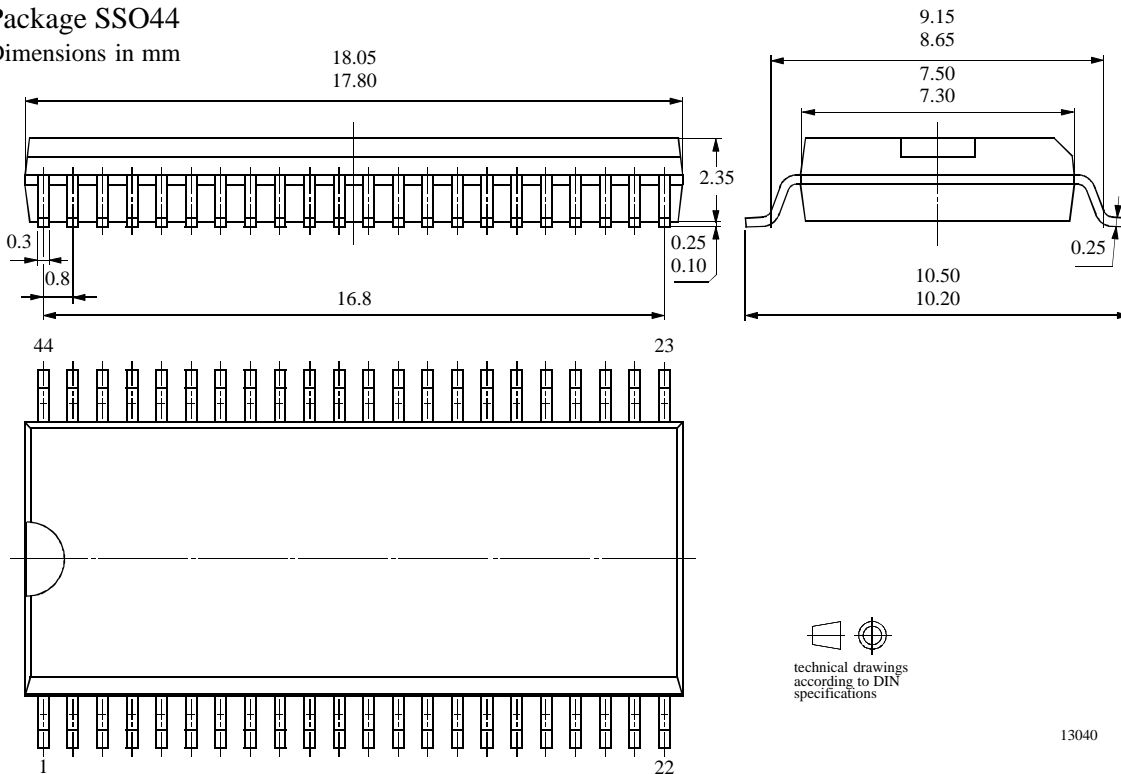

13040

## Ozone Depleting Substances Policy Statement

It is the policy of **Atmel Germany GmbH** to

1. Meet all present and future national and international statutory requirements.
2. Regularly and continuously improve the performance of our products, processes, distribution and operating systems with respect to their impact on the health and safety of our employees and the public, as well as their impact on the environment.

It is particular concern to control or eliminate releases of those substances into the atmosphere which are known as ozone depleting substances (ODSs).

The Montreal Protocol (1987) and its London Amendments (1990) intend to severely restrict the use of ODSs and forbid their use within the next ten years. Various national and international initiatives are pressing for an earlier ban on these substances.

**Atmel Germany GmbH** has been able to use its policy of continuous improvements to eliminate the use of ODSs listed in the following documents.

1. Annex A, B and list of transitional substances of the Montreal Protocol and the London Amendments respectively
2. Class I and II ozone depleting substances in the Clean Air Act Amendments of 1990 by the Environmental Protection Agency (EPA) in the USA
3. Council Decision 88/540/EEC and 91/690/EEC Annex A, B and C (transitional substances) respectively.

**Atmel Germany GmbH** can certify that our semiconductors are not manufactured with ozone depleting substances and do not contain such substances.

**We reserve the right to make changes to improve technical design and may do so without further notice.**

Parameters can vary in different applications. All operating parameters must be validated for each customer application by the customer. Should the buyer use Atmel Wireless & Microcontrollers products for any unintended or unauthorized application, the buyer shall indemnify Atmel Wireless & Microcontrollers against all claims, costs, damages, and expenses, arising out of, directly or indirectly, any claim of personal damage, injury or death associated with such unintended or unauthorized use.

**Data sheets can also be retrieved from the Internet: <http://www.atmel-wm.com>**

Atmel Germany GmbH, P.O.B. 3535, D-74025 Heilbronn, Germany  
Telephone: 49 (0)7131 67 2594, Fax number: 49 (0)7131 67 2423