

Product Features

- Near-zero propagation delay
- Direct bus connection when switches are ON
- Ultra-low quiescent power (0.2µA typical)
 - Ideally suited for notebook applications
- Packages available:
 - 24-pin 300-mil wide plastic PDIP (P24)
 - 24-pin 150-mil wide plastic QSOP (Q24)
 - 24-pin 300-mil wide plastic SOIC (S24)

Product Description

Pericom Semiconductor's PI5C series of logic circuits are produced using the Company's advanced submicron CMOS technology, achieving industry performance.

The PI5C3384A is a 10-bit, 2-port bus switches designed with a low ON resistance allowing inputs to be connected directly to outputs. The bus switch creates no additional propagational delay or additional ground bounce noise. The switches are turned ON by the Bus Enable (\overline{BE}) input signal. Two bus enable signals are provided, one for each of the upper and lower five bits of the two 10-bit buses.

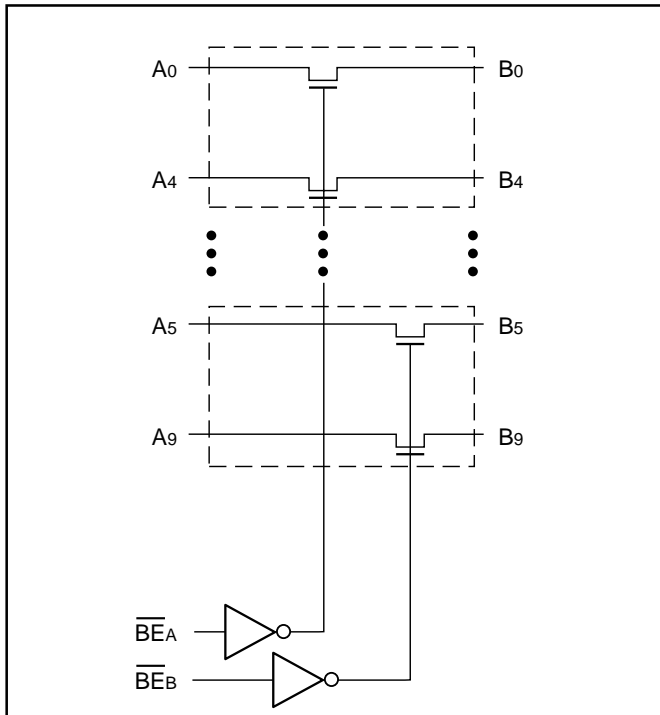
Logic Block Diagram

Truth Table⁽¹⁾

Function	\overline{BEA}	\overline{BEB}	B0-B4	B5-B9
Disconnect	H	H	Hi-Z	Hi-Z
Connect	L	H	A0-A4	Hi-Z
Connect	H	L	Hi-Z	A5-A9
Connect	L	L	A0-A4	A5-A9

Note:

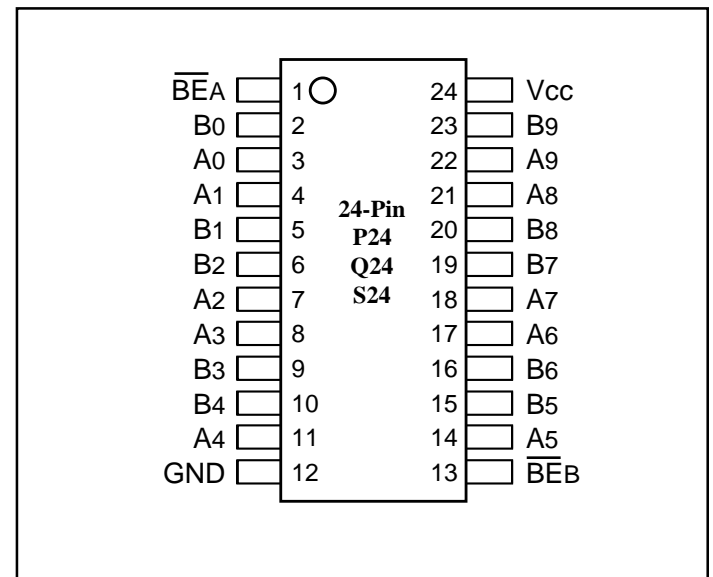
1. H = High Voltage Level
 X = Don't Care
 L = Low Voltage Level
 Hi-Z = High Impedance

Product Pin Configuration

Product Pin Description

Pin Name	Description
\overline{BEA} , \overline{BEB}	Bus Enable Inputs (Active LOW)
A0-A9	Bus A
B0-A9	Bus B
GND	Ground
Vcc	Power

Maximum Ratings

(Above which the useful life may be impaired. For user guidelines, not tested.)

Storage Temperature	-65°C to +150°C	Note: Stresses greater than those listed under MAXIMUM RATINGS may cause permanent damage to the device. This is a stress rating only and functional operation of the device at these or any other conditions above those indicated in the operational sections of this specification is not implied. Exposure to absolute maximum rating conditions for extended periods may affect reliability.
Ambient Temperature with Power Applied	-40°C to +85°C	
Supply Voltage to Ground Potential (Inputs & Vcc Only)	-0.5V to +7.0V	
Supply Voltage to Ground Potential (Outputs & D/O Only) .	-0.5V to +7.0V	
DC Input Voltage	-0.5V to +7.0V	
DC Output Current	120 mA	
Power Dissipation	0.5W	

DC Electrical Characteristics (Over the Operating Range, TA = -40°C to +85°C, VCC = 5V ±5%)

Parameters	Description	Test Conditions ⁽¹⁾	Min.	Typ ⁽²⁾	Max.	Units
V _{IH}	Input HIGH Voltage	Guaranteed Logic HIGH Level	2.0	—	—	V
V _{IL}	Input LOW Voltage	Guaranteed Logic LOW Level	-0.5	—	0.8	V
I _{IH}	Input HIGH Current	V _{CC} = Max., V _{IN} = V _{CC}	—	—	±1	µA
I _{IL}	Input LOW Current	V _{CC} = Max., V _{IN} = GND	—	—	±1	µA
I _{OZH}	High-Impedance Output Current	0 ≤ A, B ≤ V _{CC}	—	—	±1	µA
V _{IK}	Clamp Diode Voltage	V _{CC} = Min., I _{IN} = -18mA	—	-0.7	-1.2	V
I _{OS}	Short Circuit Current ⁽³⁾	A (B) = 0V, B (A) = V _{CC}	100	—	—	mA
V _H	Input Hysteresis at Control Pins		—	150	—	mV
R _{ON}	Switch On Resistance ⁽⁴⁾	V _{CC} = Min., V _{IN} = 0.0V, I _{ON} = 48mA		2	5	Ω
		V _{CC} = Min., V _{IN} = 2.4V, I _{ON} = 15mA		7	12	Ω

Capacitance (TA = 25°C, f = 1 MHz)

Parameters ⁽⁵⁾	Description	Test Conditions	Typ	Units
C _{IN}	Input Capacitance	V _{IN} = 0V	6	pF
C _{OFF}	A/B Capacitance, Switch Off	V _{IN} = 0V	9	pF
C _{ON}	A/B Capacitance, Switch On	V _{IN} = 0V	22	pF

Notes:

1. For Max. or Min. conditions, use appropriate value specified under Electrical Characteristics for the applicable device type.
2. Typical values are at V_{CC} = 5.0V, TA = 25°C ambient and maximum loading.
3. Not more than one output should be shorted at one time. Duration of the test should not exceed one second.
4. Measured by the voltage drop between A and B pin at indicated current through the switch. ON resistance is determined by the lower of the voltages on the two (A,B) pins.
5. This parameter is determined by device characterization but is not production tested.

Parameters	Description	Test Conditions	Min.	Typ. ⁽²⁾	Max.	Units
I_{CC}	Quiescent Power Supply Current	$V_{CC} = \text{Max.}$, $V_{IN} = \text{GND or } V_{CC}$	—	0.1	3.0	μA
ΔI_{CC}	Supply Current per Input @ TTL HIGH	$V_{CC} = \text{Max.}$, $V_{IN} = 3.4\text{V}^{(3)}$	—	—	2.5	mA
I_{CCD}	Supply Current per Input per MHz ⁽⁴⁾	$V_{CC} = \text{Max.}$, A and B Pins Open BE1 or BE2 = GND Control Input Toggling 50% Duty Cycle	—	—	0.25	mA/ MHz

Notes:

1. For Max. or Min. conditions, use appropriate value specified under Electrical Characteristics for the applicable device.
2. Typical values are at $V_{CC} = 5.0\text{V}$, $+25^\circ\text{C}$ ambient.
3. Per TTL driven input ($V_{IN} = 3.4\text{V}$, control inputs only); A and B pins do not contribute to I_{CC} .
4. This current applies to the control inputs only and represent the current required to switch internal capacitance at the specified frequency. The A and B inputs generate no significant AC or DC currents as they transition. This parameter is not tested, but is guaranteed by design.

PI5C3384A Switching Characteristics Over Operating Range

Parameters	Description	Conditions ⁽¹⁾	PI5C3384A		Units
			Min.	Max.	
t_{PLH} t_{PHL}	Propagation Delay ^(2,3) Ax to Bx, Bx to Ax	$C_L = 50\text{pF}$ $R_L = 500\Omega$	—	0.25	ns
t_{PZH} t_{PZL}	Bus Enable Time $\overline{\text{BEx}}$ to Ax or Bx		1.5	6.5	
t_{PHZ} t_{PLZ}	Bus Disable Time $\overline{\text{BEx}}$ to Ax or Bx		1.5	5.5	

Notes:

1. See test circuit and waveforms.
2. This parameter is guaranteed but not tested on Propagation Delays.
3. The bus switch contributes no propagational delay other than the RC delay of the ON resistance of the switch and the load capacitance. The time constant for the switch alone is of the order of 0.25ns for 50pF load. Since this time constant is much smaller than the rise/fall times of typical driving signals, it adds very little propagational delay to the system. Propagational delay of the bus switch when used in a system is determined by the driving circuit on the driving side of the switch and its interaction with the load on the driven side.