

3.3V, 8-Channel, 2:1 Mux/DeMux Gigabit Ethernet LAN Switch with Single Enable and Enhanced ESD Protection

Features

- R_{ON} is 4Ω typical
- Low bit-to-bit skew: 200ps
- Low crosstalk: -27dB @ 250MHz
- Near-Zero propagation delay: 250ps
- Switching speed: 9ns
- Channel On-Capacitance: 9.5pF (typical)
- V_{CC} Operating Range: +3.0V to +3.6V
- Enhanced ESD Protection:
 - 8kV (contact)⁽¹⁾
 - Switch pins: 1.1kV (machine model), 12kV (human body model)
- >700 MHz bandwidth (or data frequency)
- Packaging (Pb-free & Green available): 48-pin 240 mil wide plastic TSSOP (A)

Applications

- Dual Physical Layer Device sharing to one interface connector
- SONET OC-12(622Mbps) signal routing
- Routes physical layer signals for 10/100/1000 Mbit Ethernet

Block Diagram

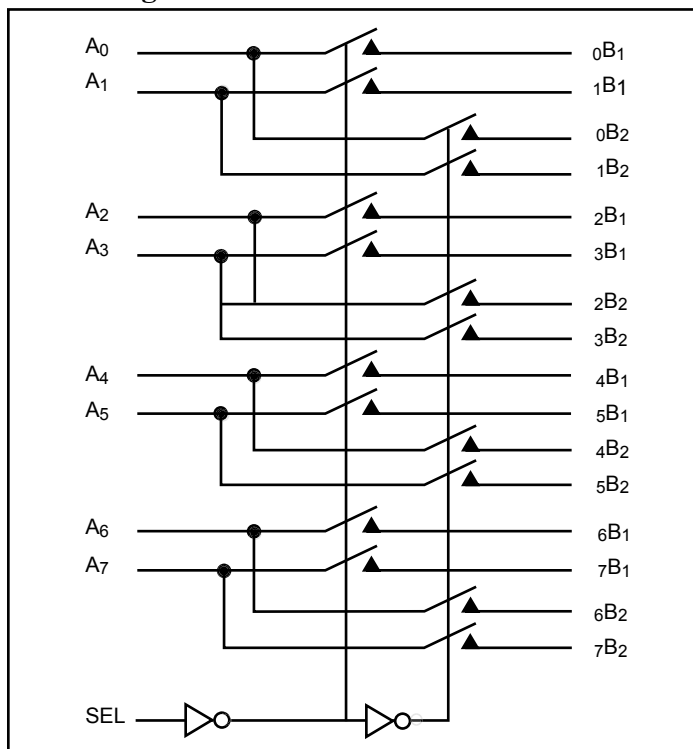

Description

The PI3L301D-A is a 8-Channel, 2:1 multiplexer/demultiplexer LAN Switch. Industry leading advantages include a propagation delay of less than 250ps, resulting from its low channel resistance and I/O capacitance. The device multiplexes differential outputs from a Gigabit Ethernet transceiver (PHY) device to one of two corresponding B1 or B2 outputs. The switch is bidirectional and offers little or no attenuation of the high-speed signals at the outputs. It is designed for low bit-to-bit skew, high channel-to-channel noise isolation and is compatible with various standards, such as 10/100/1000 Base-T (Ethernet).

Generally, this part can be used to replace mechanical relays in low-voltage LAN applications that interface a physical layer over CAT 5 or CAT 6 unshielded twisted pair cable through an isolation transformer.

Note: 1. IEC 61000-4-2

Pin Description

V_{DD}	1	48	0B1
A_0	2	47	1B1
GND	3	46	GND
A_1	4	45	0B2
GND	5	44	1B2
V_{DD}	6	43	GND
GND	7	42	2B1
A_2	8	41	3B1
GND	9	40	GND
A_3	10	39	2B2
GND	11	38	3B2
V_{DD}	12	37	GND
GND	13	36	V_{DD}
NC	14	35	4B1
A_4	15	34	5B1
GND	16	33	GND
A_5	17	32	4B2
GND	18	31	5B2
V_{DD}	19	30	GND
GND	20	29	6B1
A_6	21	28	7B1
GND	22	27	GND
A_7	23	26	6B2
SEL	24	25	7B2

Maximum Ratings

(Above which useful life may be impaired. For user guidelines, not tested.)

Storage Temperature.....	-65°C to +150°C
Supply Voltage to Ground Potential.....	-0.5V to +4.0V
DC Input Voltage.....	-0.5V to +5.5V
DC Output Current.....	120mA
Power Dissipation.....	0.5W

Note:

Stresses greater than those listed under MAXIMUM RATINGS may cause permanent damage to the device. This is a stress rating only and functional operation of the device at these or any other conditions above those indicated in the operational sections of this specification is not implied. Exposure to absolute maximum rating conditions for extended periods may affect reliability.

Truth Table

Function	SEL
A_N to $_NB_1$	L
A_N to $_NB_2$	H

DC Electrical Characteristics for 1000 Base-T Ethernet Switching over Operating Range

($T_A = -40^{\circ}\text{C}$ to $+85^{\circ}\text{C}$, $V_{CC} = 3.3\text{V} \pm 10\%$)

Parameter	Description	Test Conditions ⁽¹⁾	Min.	Typ. ⁽²⁾	Max.	Units
V_{IH}	Input HIGH Voltage	Guaranteed HIGH level	2			V
V_{IL}	Input LOW Voltage	Guaranteed LOW level	-0.5		0.8	
V_{IK}	Clamp Diode Voltage	$V_{CC} = \text{Max.}, I_{IN} = -18\text{mA}$		-0.7	-1.2	
I_{IH}	Input HIGH Current	$V_{CC} = \text{Max.}, V_{IN} = V_{CC}$			± 5	μA
I_{IL}	Input LOW Current	$V_{CC} = \text{Max.}, V_{IN} = \text{GND}$			± 5	
R_{ON}	Switch On-Resistance ⁽³⁾	$V_{CC} = \text{Min.}, 1.5\text{V} \leq V_{IN} \leq V_{CC}, I_{IN} = -40\text{mA}$		4	8	Ω
$R_{FLAT(ON)}$	On-Resistance Flatness ⁽⁴⁾	$V_{CC} = \text{Min.}, V_{IN} @ 1.5\text{V}$ and $V_{CC}, I_{IN} = -40\text{mA}$		1		
ΔR_{ON}	On-Resistance match from center ports to any other port ⁽⁴⁾	$V_{CC} = \text{Min.}, 1.5\text{V} \leq V_{IN} \leq V_{CC}, I_{IN} = -40\text{mA}$		0.9	2	

DC Electrical Characteristics for 10/100 Base-T Ethernet Switching over Operating Range

($T_A = -40^{\circ}\text{C}$ to $+85^{\circ}\text{C}$, $V_{CC} = 3.3\text{V} \pm 10\%$)

Parameter	Description	Test Conditions ⁽¹⁾	Min.	Typ. ⁽²⁾	Max.	Units
V_{IH}	Input HIGH Voltage	Guaranteed HIGH level	2.0			V
V_{IL}	Input LOW Voltage	Guaranteed LOW level	-0.5		0.8	
V_{IK}	Clamp Diode Voltage	$V_{CC} = \text{Max.}, I_{IN} = -18\text{mA}$		-0.7	-1.2	
I_{IH}	Input HIGH Current	$V_{CC} = \text{Max.}, V_{IN} = V_{CC}$			± 5	μA
I_{IL}	Input LOW Current	$V_{CC} = \text{Max.}, V_{IN} = \text{GND}$			± 5	
R_{ON}	Switch On-Resistance ⁽³⁾	$V_{CC} = \text{Min.}, 1.25\text{V} \leq V_{IN} \leq V_{CC}, I_{IN} = -10\text{mA}$ to -30mA			8	Ω
$R_{FLAT(ON)}$	On-Resistance Flatness ⁽⁴⁾	$V_{CC} = \text{Min.}, V_{IN} @ 1.25\text{V}$ and $V_{CC}, I_{IN} = -10\text{mA}$ to -30mA		1.0		
ΔR_{ON}	On-Resistance match from center ports to any other port ⁽⁴⁾	$V_{CC} = \text{Min.}, 1.25\text{V} \leq V_{IN} \leq V_{CC}, I_{IN} = -10\text{mA}$ to -30mA		0.9	2.0	

Capacitance ($T_A = 25^{\circ}\text{C}$, $f = 1\text{MHz}$)

Parameters ⁽⁴⁾	Description	Test Conditions	Typ.	Max.	Units
C_{IN}	Input Capacitance	$V_{IN} = 0\text{V}$	3.1	3.6	pF
$C_{OFF(B1, B2)}$	Port B Capacitance, Switch OFF		2.8	6.0	
$C_{ON(A/B)}$	A/B Capacitance, Switch ON		9.5 ⁽⁵⁾	10.9	

Notes:

- For max. or min. conditions, use appropriate value specified under Electrical Characteristics for the applicable device type.
- Typical values are at $V_{CC} = 3.3\text{V}$, $T_A = 25^{\circ}\text{C}$ ambient and maximum loading.
- Measured by the voltage drop between A and B pins at indicated current through the switch. On-Resistance is determined by the lower of the voltages on the two (A & B) pins.
- This parameter is determined by device characterization but is not production tested.
- Measured on worst case corner pin.

Power Supply Characteristics

Parameters	Description	Test Conditions ⁽¹⁾	Min.	Typ. ⁽²⁾	Max.	Units
I _{CC}	Quiescent Power Supply Current	V _{CC} = Max., V _{IN} = GND or V _{CC}			800	μA

Dynamic Electrical Characteristics Over the Operating Range (T_A=-40° to +85°C, V_{CC}=3.3V±10%, GND=0V)

Parameter	Description	Test Conditions ⁽¹⁾	Min.	Typ. ⁽²⁾	Max.	Units
X _{TALK}	Crosstalk	f = 250MHz, See Fig. 2		-27		dB
O _{IRR}	OFF Isolation	f = 250MHz, See Fig. 3		-32		
BW	Bandwidth -3dB	See Fig. 1		700		MHz

Switching Characteristics

Parameter	Description	Test Conditions	Min.	Typ. ⁽²⁾	Max.	Units
t _{PD}	Propagation Delay ^(3,4)			0.25		ns
t _{PZH} , t _{PZL}	Line Enable Time - SEL to A _N , B _N		0.5		15	
t _{PHZ} , t _{PLZ}	Line Disable Time - SEL to A _N , B _N		0.5		9	
t _{SK(o)}	Output Skew between center port (A4 to A5) to any other port ⁽⁴⁾			0.1	0.2	
t _{SK(p)}	Skew between opposite transitions of the same output (t _{PHL} - t _{PLH}) ⁽⁴⁾			0.1	0.2	

Notes:

- For max. or min. conditions, use appropriate value specified under Electrical Characteristics for the applicable device type.
- Typical values are at V_{CC} = 3.3V, T_A = 25°C ambient and maximum loading.
- The bus switch contributes no propagational delay other than the RC delay of the On-Resistance of the switch and the load capacitance. The time constant for the switch alone is of the order of 0.25ns for 10pF load. Since this time constant is much smaller than the rise/fall times of typical driving signals, it adds very little propagational delay to the system. Propagational delay of the bus switch when used in a system is determined by the driving circuit on the driving side of the switch and its interactions with the load on the driven side.
- Guaranteed by design.

Test Circuit for Electrical Characteristics

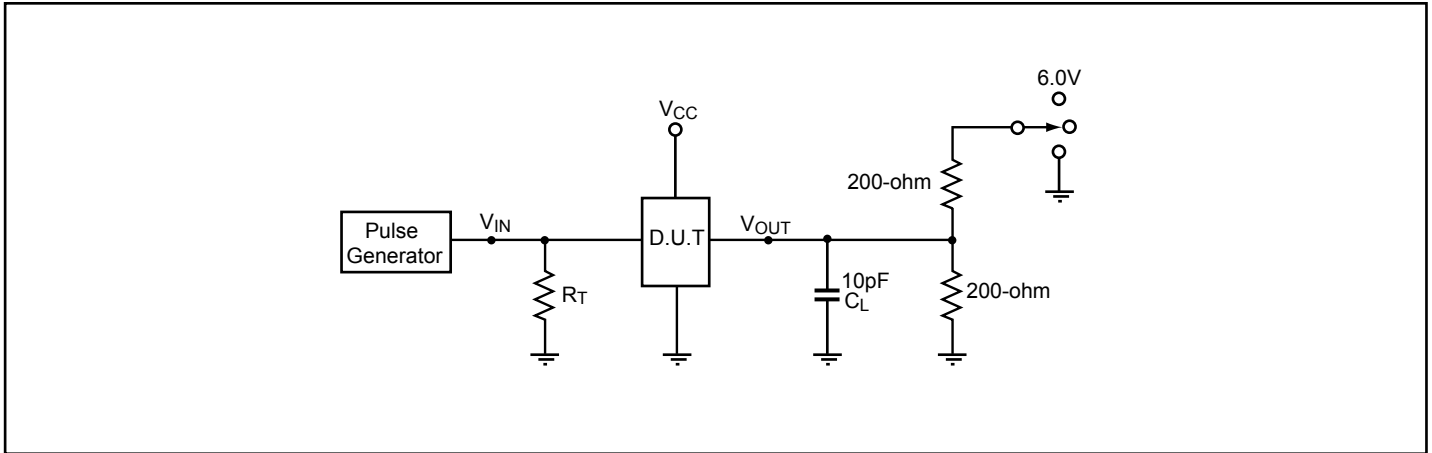

Notes:

C_L = Load capacitance: includes jig and probe capacitance.
 R_T = Termination resistance: should be equal to Z_{OUT} of the Pulse Generator
 All input impulses are supplied by generators having the following characteristics: $f = 10\text{MHz}$, $Z_O = 50\Omega$, $t_R \leq 2.5\text{ns}$, $t_F \leq 2.5\text{ns}$.
 The outputs are measured one at a time with one transition per measurement.

Switch Positions

Test	Switch
t_{PLZ} , t_{PZL} (output on B-side)	6.0V
t_{PHZ} , t_{PZH} (output on B-side)	GND
Prop Delay	Open

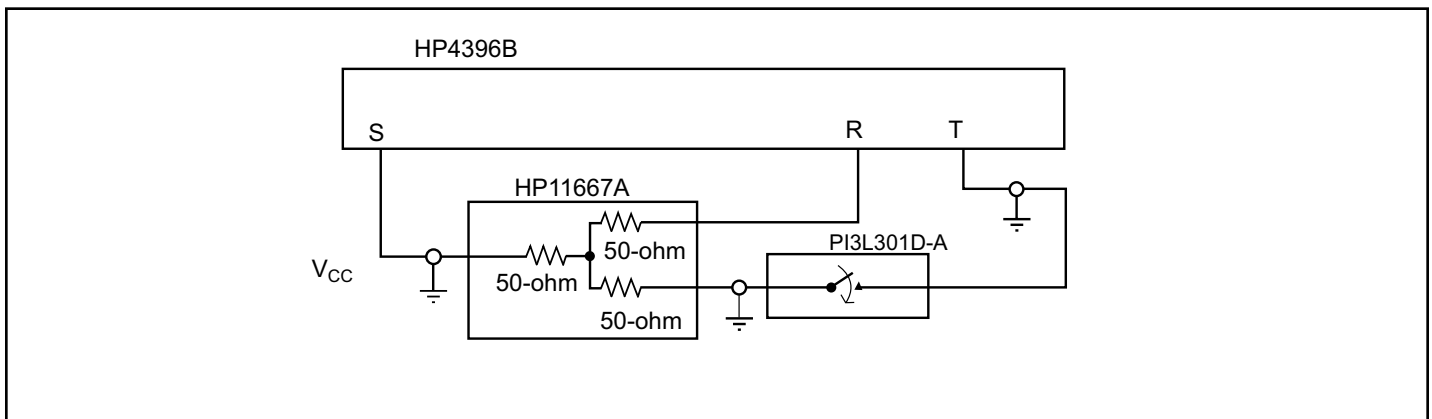

Figure 1. Bandwidth -3db Testing

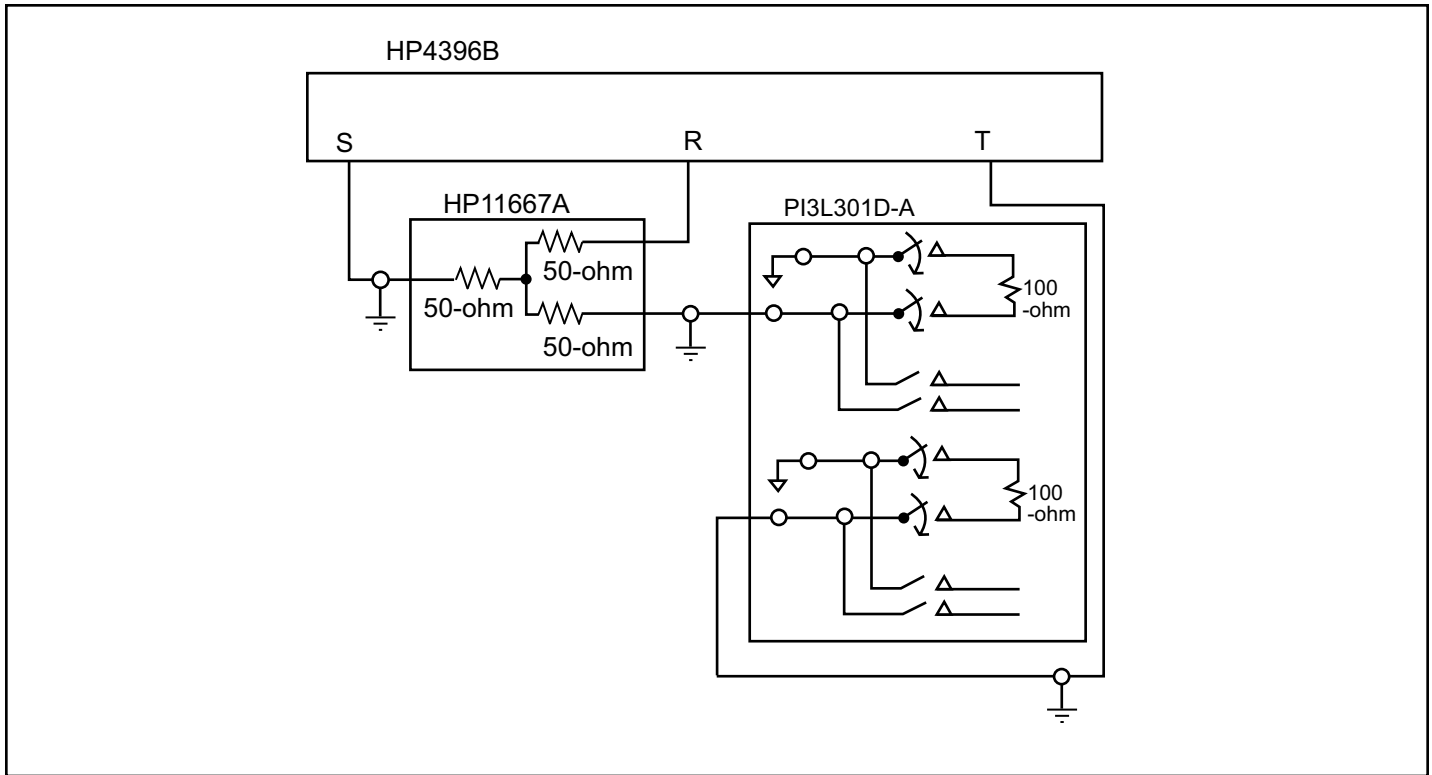

Figure 2. Crosstalk Test Setup

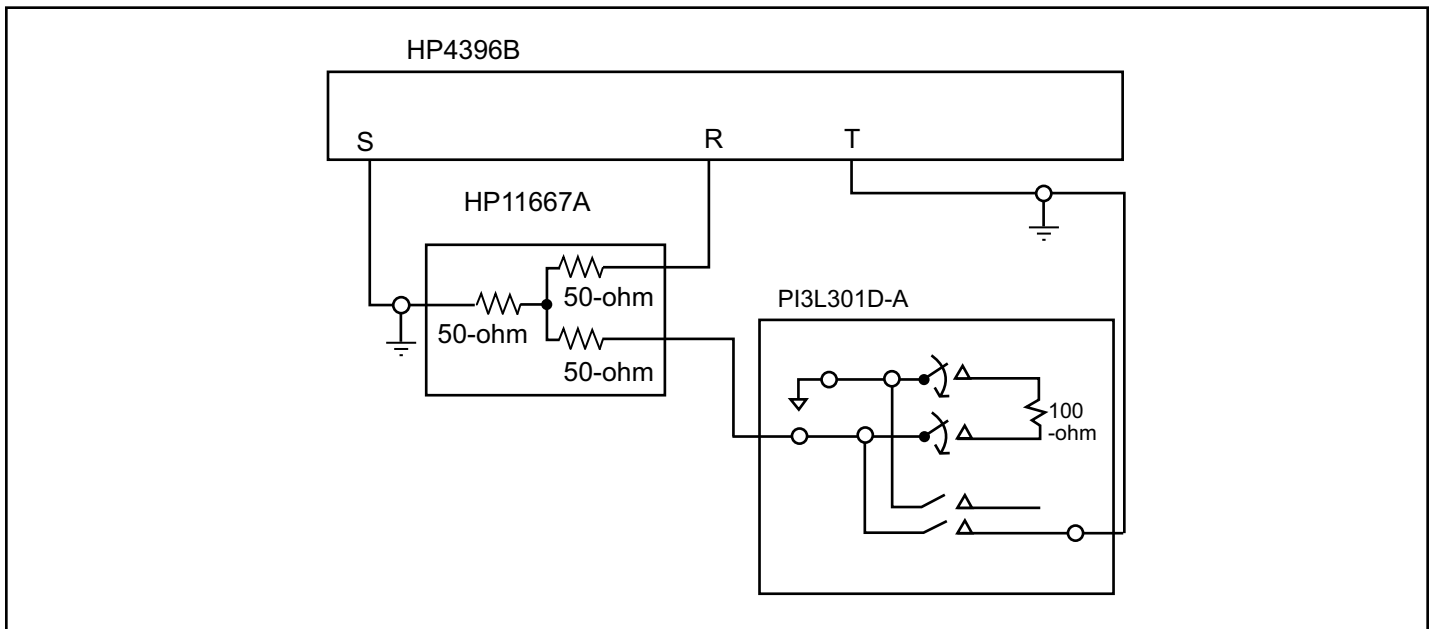
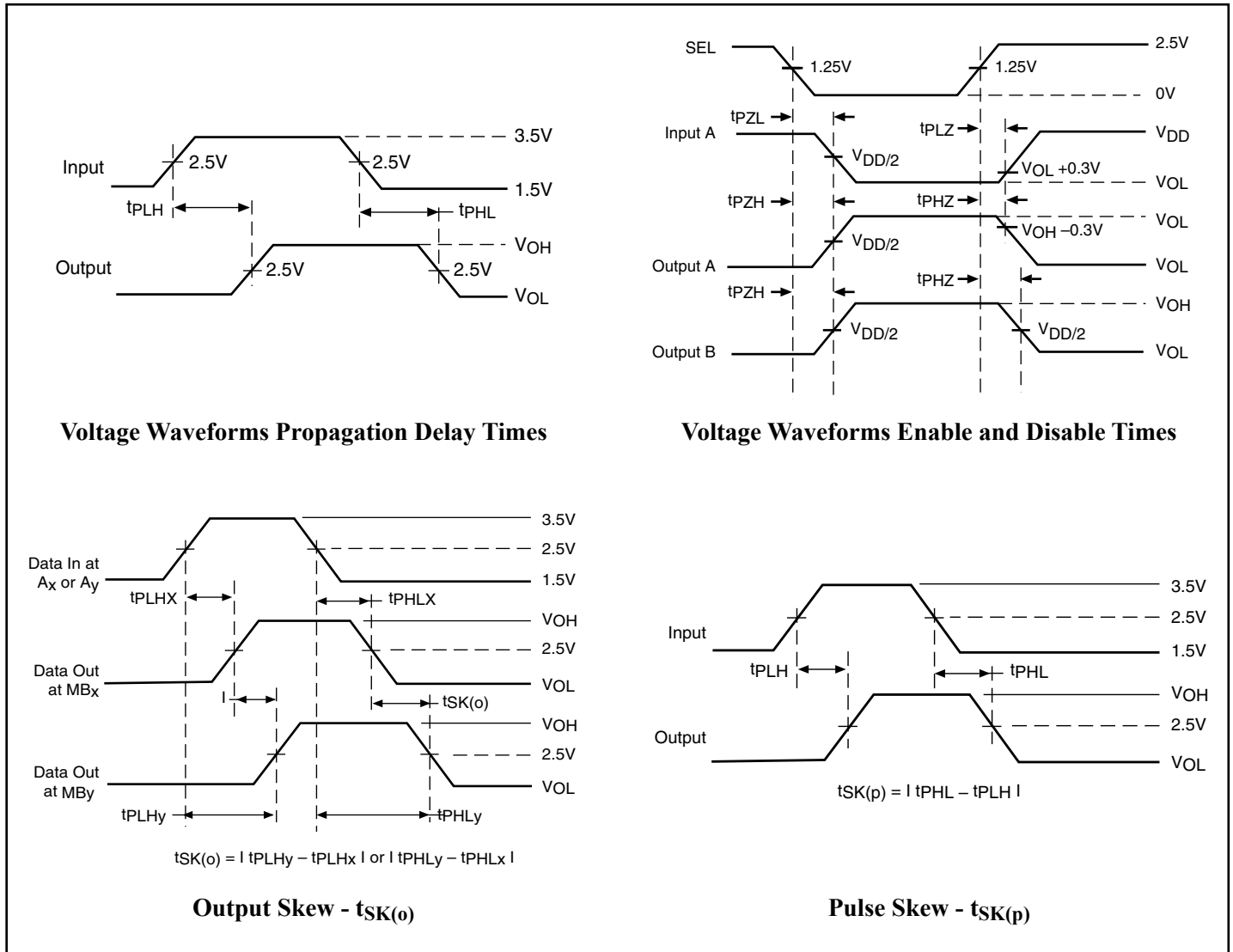

Figure 3 . Off Isolation Test Setup

Switching Waveforms



Applications Information

Logic Inputs

The logic control inputs can be driven up to +3.6V regardless of the supply voltage. For example, given a +3.3V supply, the output enables or select pins may be driven low to 0V and high to 3.6V. Driving IN Rail-to-Rail® minimizes power consumption.

Power-Supply Sequencing

Proper power-supply sequencing is advised for all CMOS devices. It is recommended to always apply V_{CC} before applying signals to the input/output or control pins.

Rail-to-Rail is a registered trademark of Nippon Motorola, Ltd

Packaging Mechanical: 48-Pin TSSOP (A)

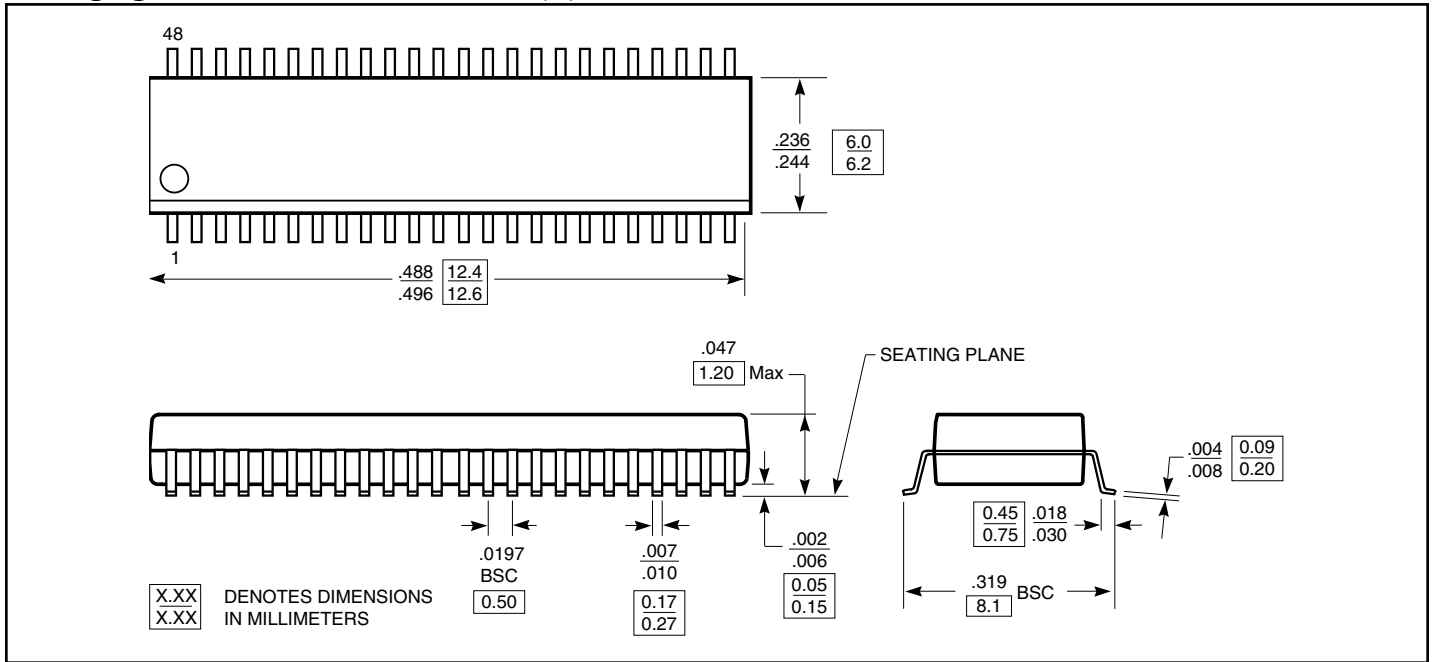

Ordering Information

Ordering Code	Package Code	Package Description
PI3L301D-AA	A	48-pin 240 mil wide plastic TSSOP
PI3L301D-AAE	A	Pb-free & Green, 48-pin 240 mil wide plastic TSSOP

Notes:

- Thermal characteristics can be found on the company web site at www.pericom.com/packaging/
- Add 'x' for tape and reel packaging