

1.8V, 1.8GHz, Differential Broadband Signal Switch, 2-Differential Channel, 2:1 Mux/DeMux Switch, w/ Single Enable

Features

- SAS, SATA2, XAUI Switch
- 2 Differential Channel, 2:1 Mux/DeMux
- Bandwidth of 2.0 GHz (-3dB)
- Low Bit-to-Bit Skew : <5 ps
- Low Crosstalk: -26dB @ 3.2 Gbps
- Low Off Isolation: -35dB @ 3.2 Gbps
- V_{DD} Voltage: +1.8V
- ESD Tolerance: 8kV HBM I/O, 2kV HBM select pin
- Packaging (Pb-free & Green):
 - 20-Lead QSOP
 - 28-Contact TQFN

Description

Pericom Semiconductor's PI2DBS212 is an 1:2 differential channel multiplexer/demultiplexer switch. Using a specialized design scheme, Pericom has been able to achieve a performance of 3Gbps data rate mux/de-mux function. Due to its bi-directional nature, the PI2DBS212 can be used to allocate bandwidth to two different locations as a demux, or connect two high-speed sources to a single receiver as a mux.

The PI2DBS212 will target the following standards: SAS, SATA I, SATA II, XAUI, INFINIBAND, HYPERTRANSPORT, and RAP ID I/O, for application in computers, consumer electronics, instrumentation, etc.

Block Diagram

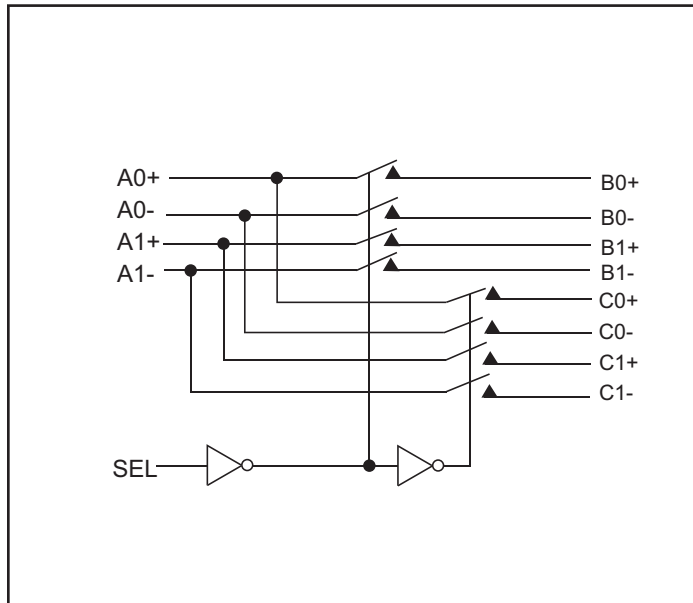

Truth Table

Function	SEL
Port A to Port B	L
Port A to Port C	H

Pin Description - 20-Lead QSOP

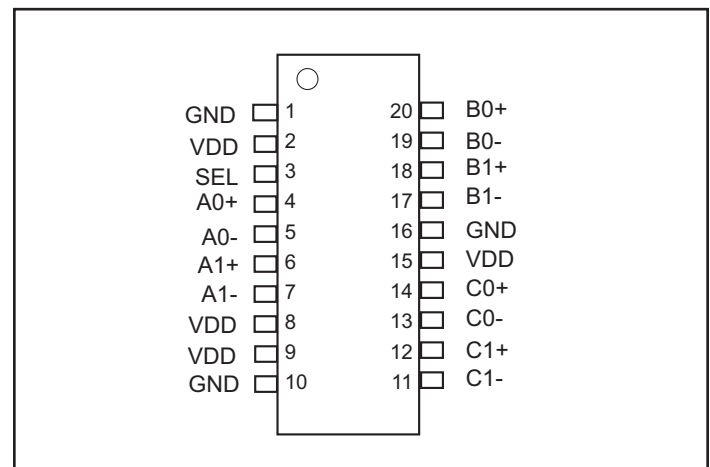

Pin Description - 28-Contact TQFN

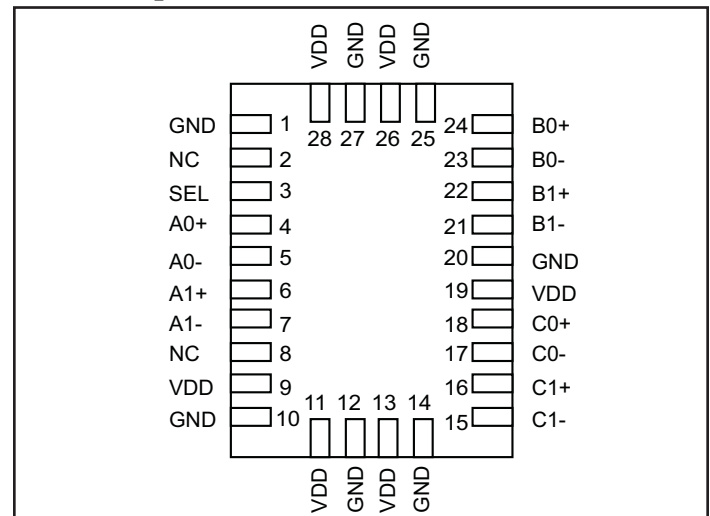

Maximum Ratings

(Above which useful life may be impaired. For user guidelines, not tested.)

Storage Temperature.....	-65°C to +150°C
Supply Voltage to Ground Potential.....	-0.5V to +2.5V
DC Input Voltage	-0.5V to V _{DD}
DC Output Current.....	120mA
Power Dissipation.....	0.5W

Note:

Stresses greater than those listed under MAXIMUM RATINGS may cause permanent damage to the device. This is a stress rating only and functional operation of the device at these or any other conditions above those indicated in the operational sections of this specification is not implied. Exposure to absolute maximum rating conditions for extended periods may affect reliability.

DC Electrical Characteristics for Switching over Operating Range (T_A = -40°C to +85°C, V_{DD} = 1.8V ±10%)

Parameter	Description	Test Conditions ⁽¹⁾	Min.	Typ. ⁽²⁾	Max.	Units
V _{IH}	Input HIGH Voltage	Guaranteed HIGH level	0.65 x V _{DD}			V
V _{IL}	Input LOW Voltage	Guaranteed LOW level	-0.5		0.35 x V _{DD}	
V _{IK}	Clamp Diode Voltage	V _{DD} = Max., I _{IN} = -18mA		-0.7	-1.2	
I _{IH}	Input HIGH Current	V _{DD} = Max., V _{IN} = V _{CC}			±5	µA
I _{IL}	Input LOW Current	V _{DD} = Max., V _{IN} = GND			±5	
R _{ON}	ON Resistance	V _{DD} = Min., V _{IN} = 1.3V, I _{IN} = 40mA			10	Ohm
C _{ON}	Capacitance ON (A/B)	V _{IN} = 0, V _{DD} = 1.8V		3.5		pF

Notes:

- For Max. or Min. conditions, use appropriate value specified under Electrical Characteristics for the applicable device type.
- Typical values are at V_{DD} = 1.8V, T_A = 25°C ambient and maximum loading.

Power Supply Characteristics

Parameters	Description	Test Conditions ⁽¹⁾	Min.	Typ. ⁽²⁾	Max.	Units
I _{DD}	Quiescent Power Supply Current	V _{DD} = Max., V _{IN} and V _{SEL} = GND or V _{DD}		300	400	µA

Notes:

- For Max. or Min. conditions, use appropriate value specified under Electrical Characteristics for the applicable device type.
- Typical values are at V_{DD} = 1.8V, T_A = 25°C ambient and maximum loading.

Dynamic Electrical Characteristics Over the Operating Range (T_A = -40° to +85°C, V_{DD} = 1.8V±10%)

Parameter	Description	Test Conditions	Min.	Typ. ⁽¹⁾	Max.	Units
X _{TALK}	Crosstalk	See Fig. 1 for Measurement Setup, f = 1.65 GHz		-26		dB
O _{IRR}	OFF Isolation	See Fig. 2 for Measurement Setup, f = 1.65 GHz		-35		
I _{LOSS}	Differential Insertion Loss	f = 1.65 GHz		-1.8		
BW	Bandwidth	@ -3 dB		2.0		GHz

Notes:

- Guaranteed by design. Typical values are at V_{DD} = 1.8V, T_A = 25°C ambient, and maximum loading.

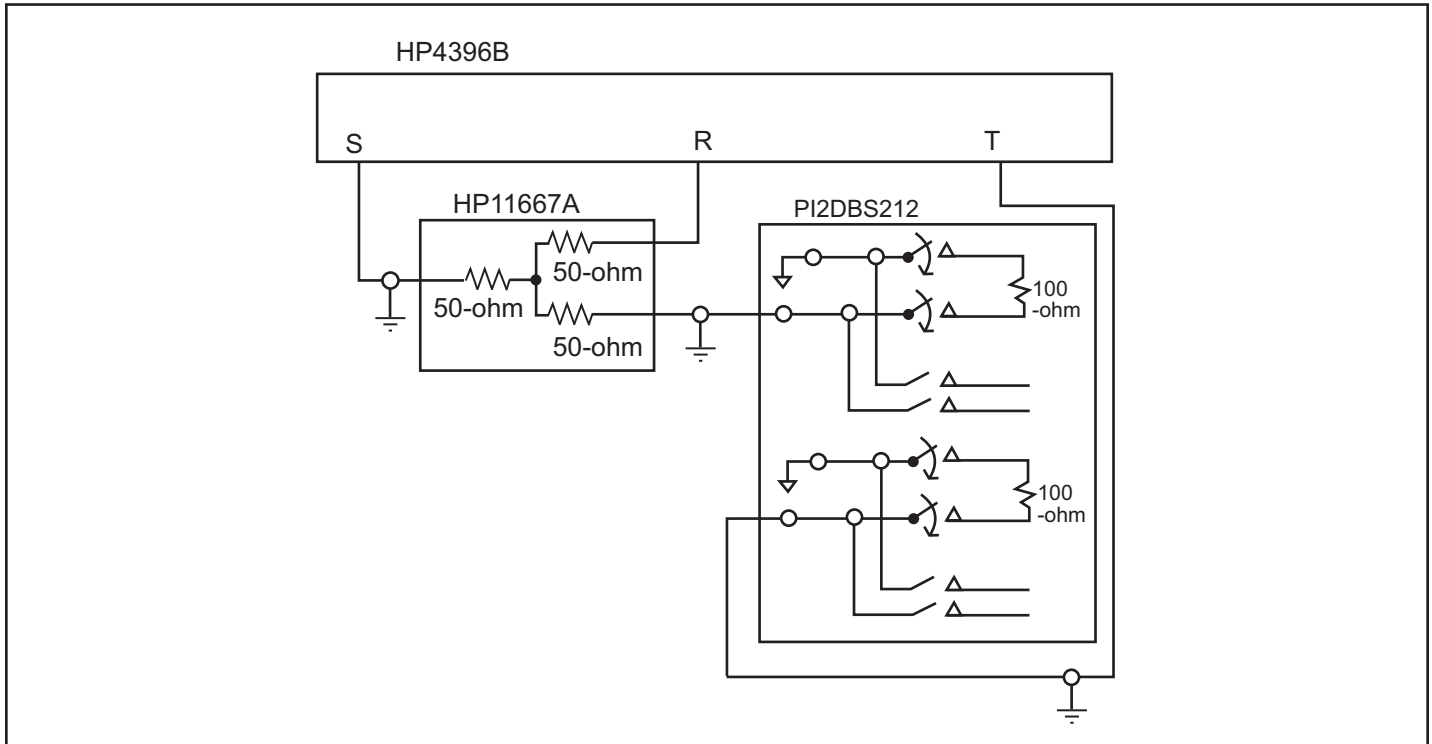

Fig 1. Crosstalk Setup

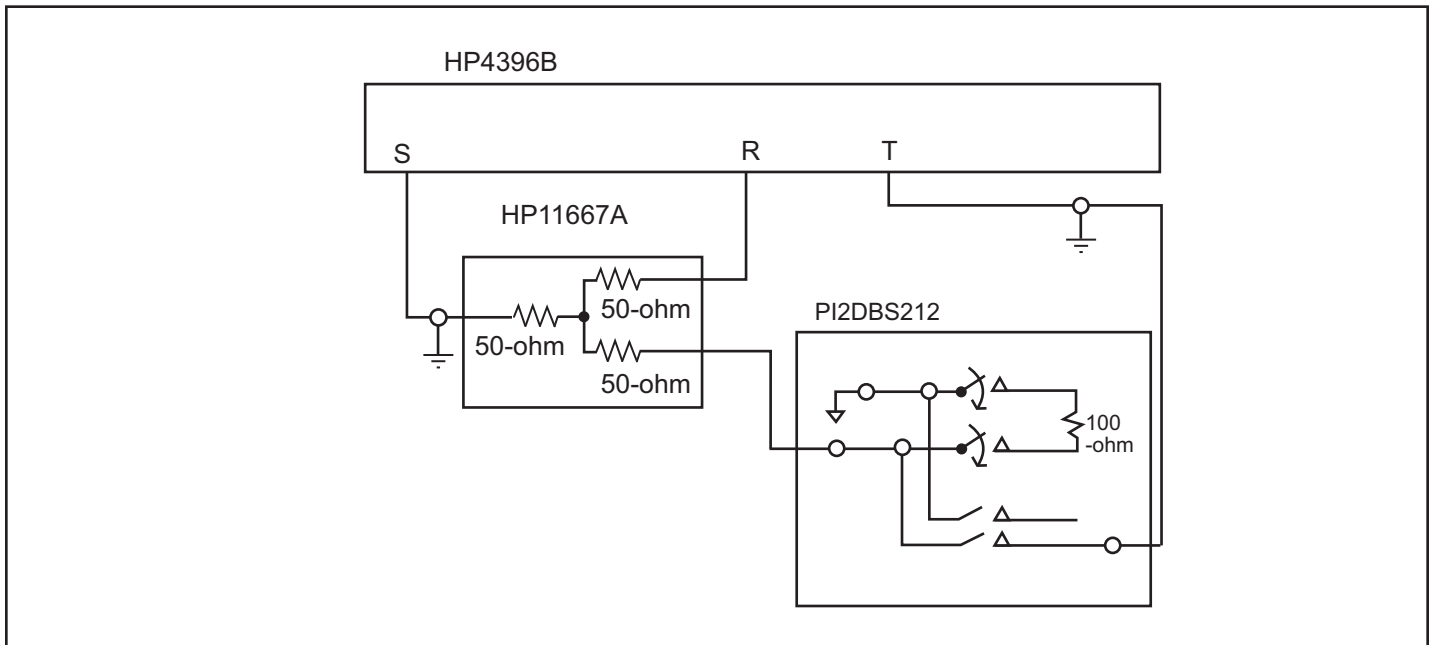

Fig 2. Off-isolation setup

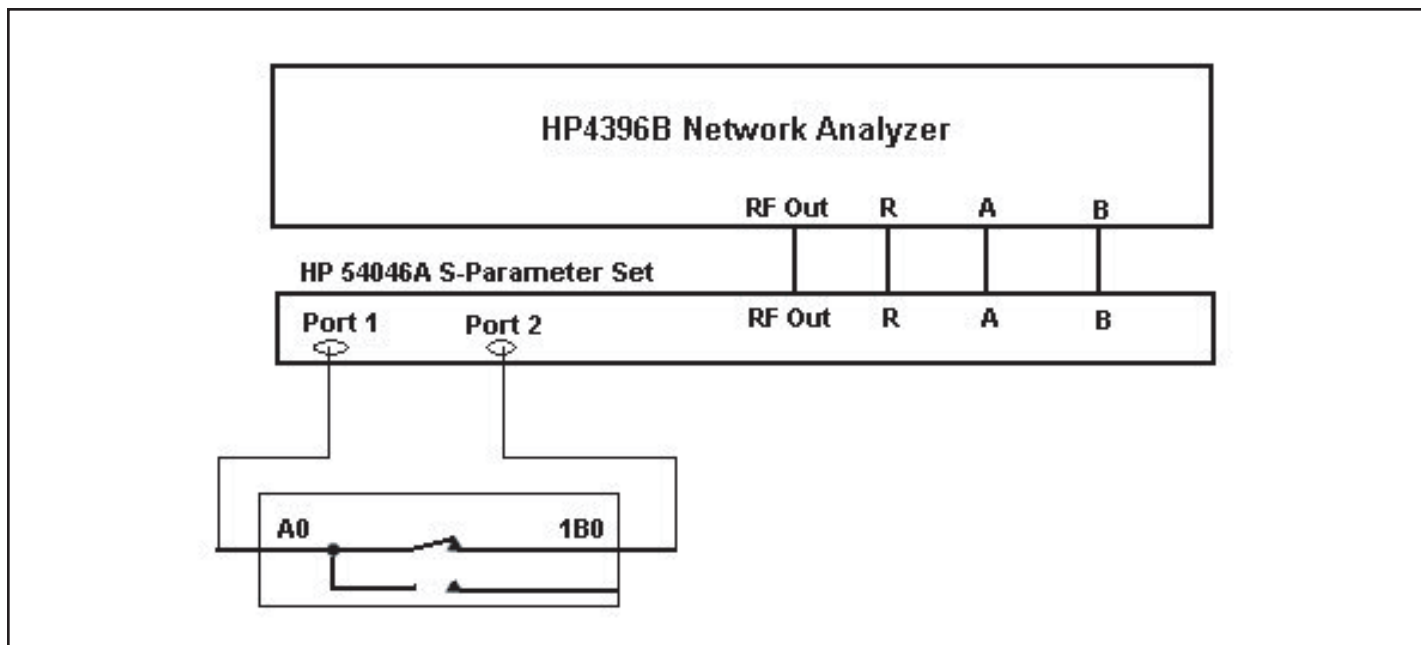

Fig 3. S21 (Insertion Loss) and S11 (Reflection) SET-UP

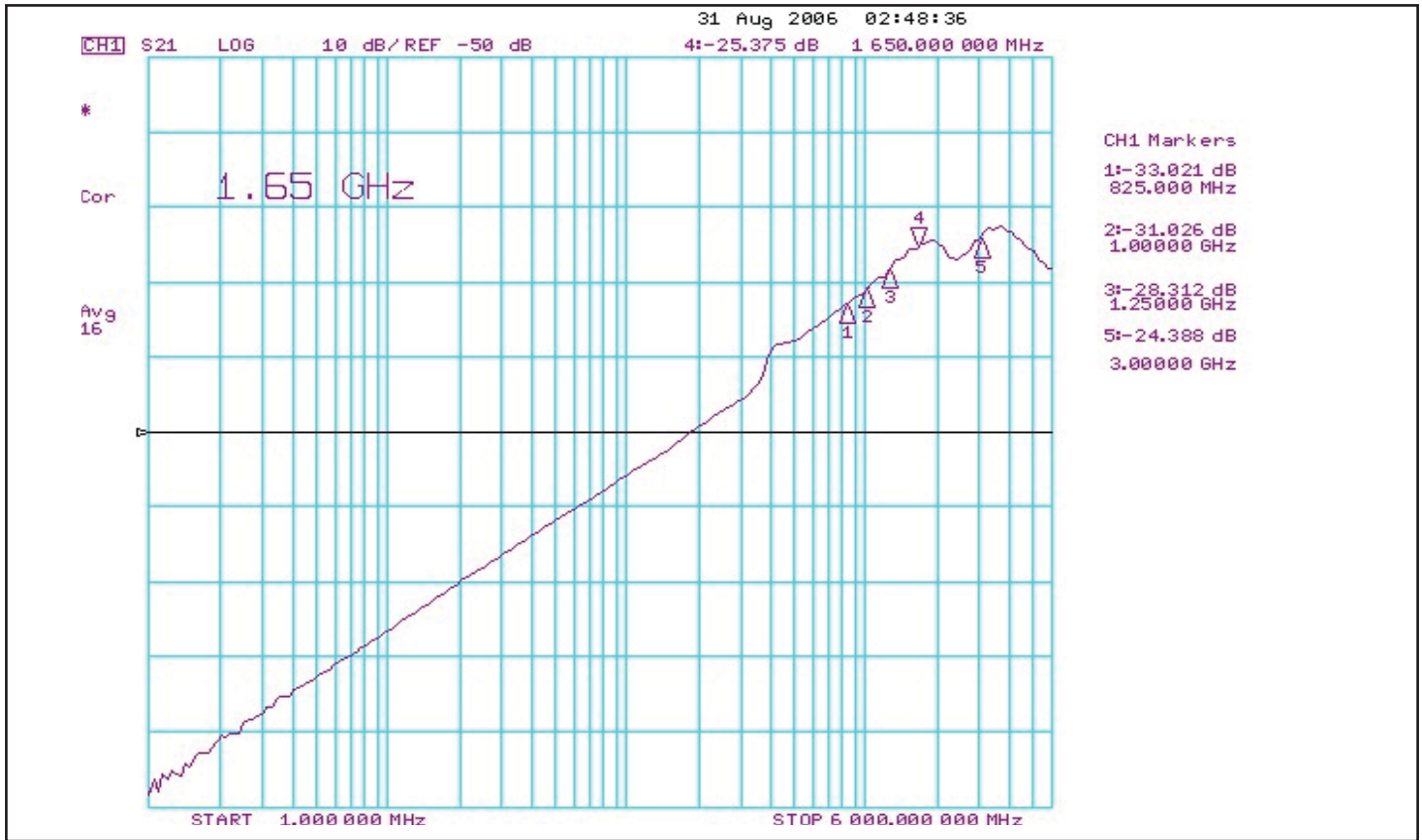

Fig 4. Crosstalk

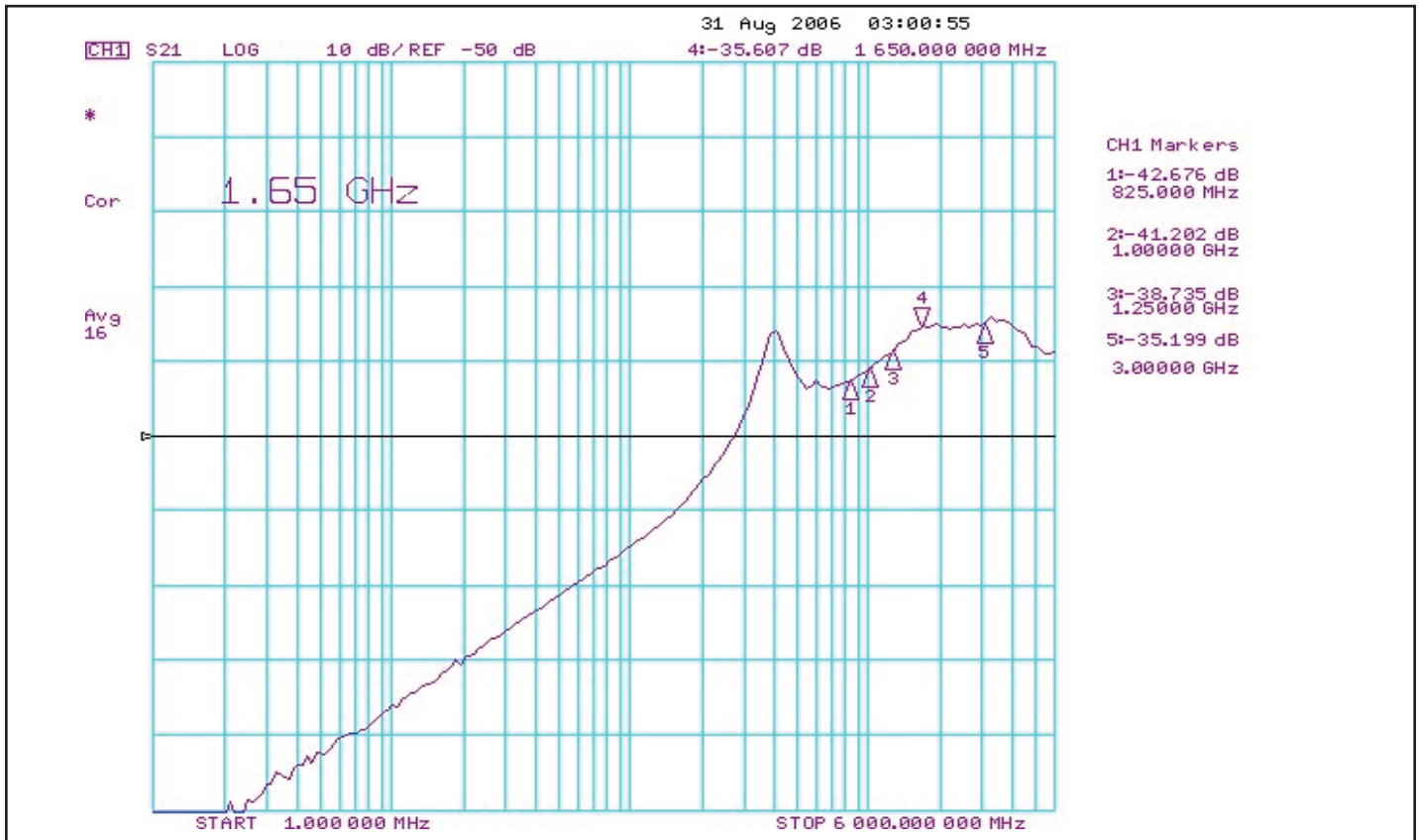

Fig 5. Off Isolation

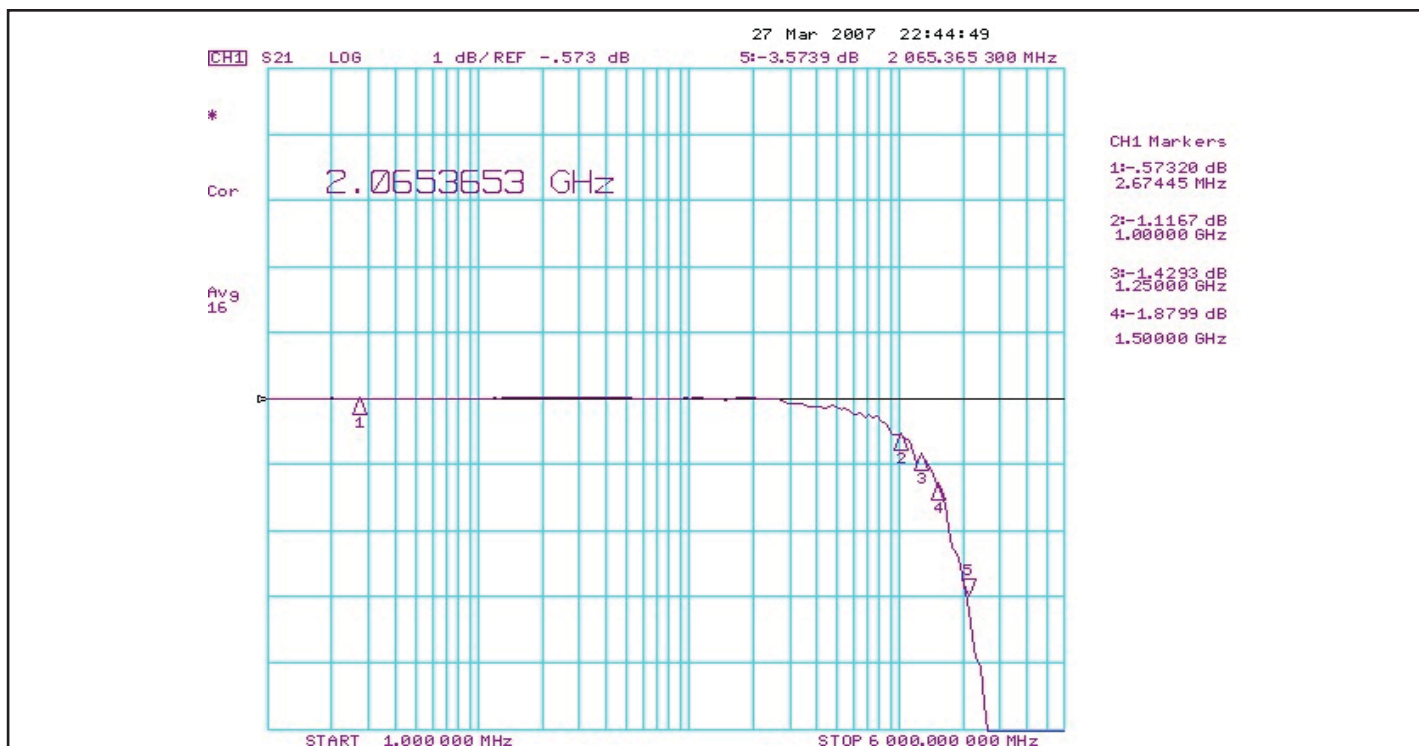

Fig 6. Bandwidth

Switching Characteristics ($T_A = -40^\circ$ to $+85^\circ\text{C}$, $V_{DD} = 1.8\text{V} \pm 10\%$)

Parameter	Description ⁽¹⁾	Min.	Typ.	Max.	Units
t_{pZH} , t_{pZL}	Line Enable Time - SEL to A_N , B_N	0.5		8.0	ns
t_{pHZ} , t_{pLZ}	Line Disable Time - SEL to A_N , B_N	0.5		4.0	
t_{b-b}	Bit-to-bit skew, within same differential pair			5	ps
t_{ch-ch}	Channel-to-channel timing skew			12	
t_{PD}	Propagation Delay, A to B or C / B or C to A	50		150	

Notes:

- For max. or min. conditions, use appropriate value specified under Electrical Characteristics for the applicable device type.

Test Circuit for Electrical Characteristics

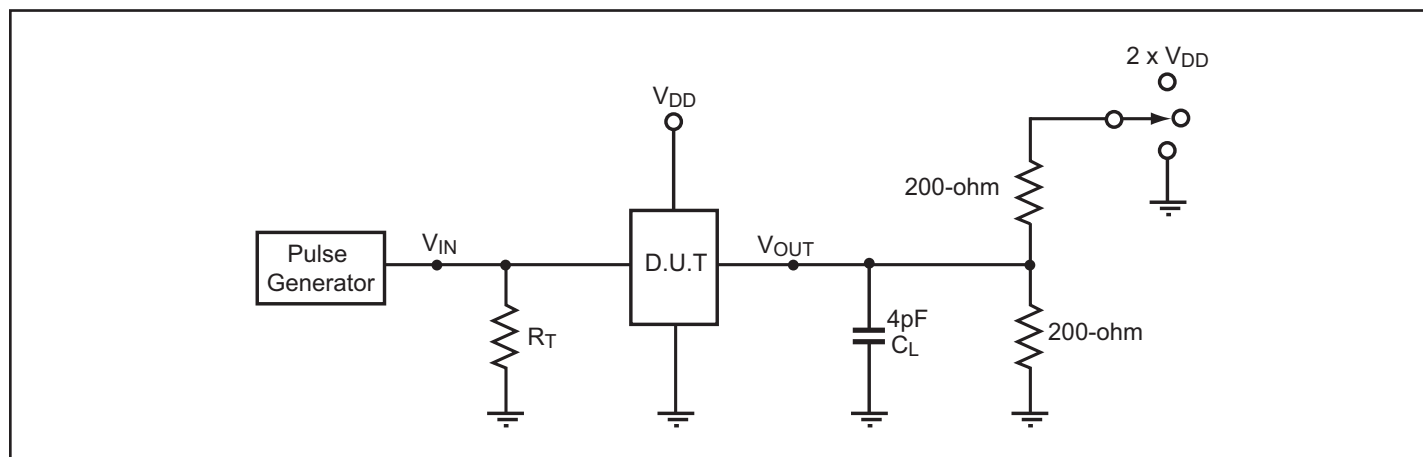

Notes:

- C_L = Load capacitance: includes jig and probe capacitance.
- R_T = Termination resistance: should be equal to Z_{OUT} of the Pulse Generator
- Waveform 1 is for an output with internal conditions such that the output is low except when disabled by the output control.
- Waveform 2 is for an output with internal conditions such that the output is high except when disabled by the output control.
- All input impulses are supplied by generators having the following characteristics: $PRR \leq 10$ MHz, $Z_O = 50\Omega$, $t_R \leq 2.5\text{ns}$, $t_F \leq 2.5\text{ns}$.
- The outputs are measured one at a time with one transition per measurement.

Switch Positions

Test	Switch
t_{pLZ} , t_{pZL} (output on B-side)	$2 \times V_{DD}$
t_{pHZ} , t_{pZH} (output on B-side)	GND
Prop Delay	Open

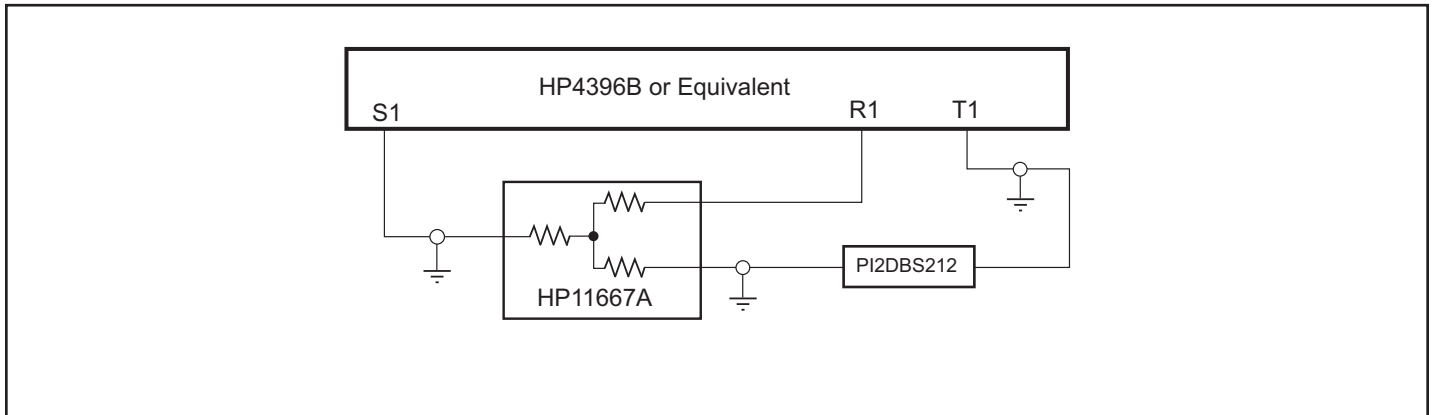
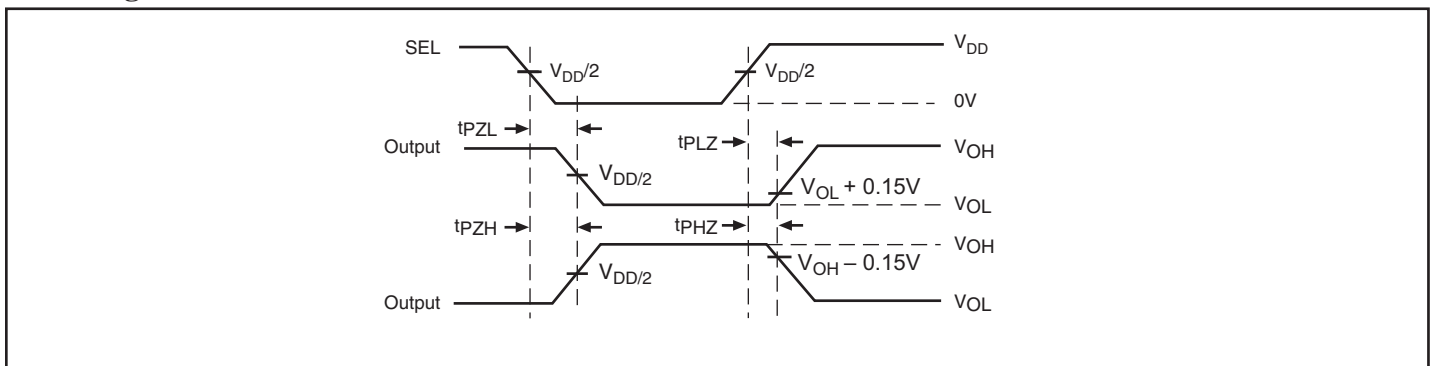
Test Circuit for Dynamic Electrical Characteristics

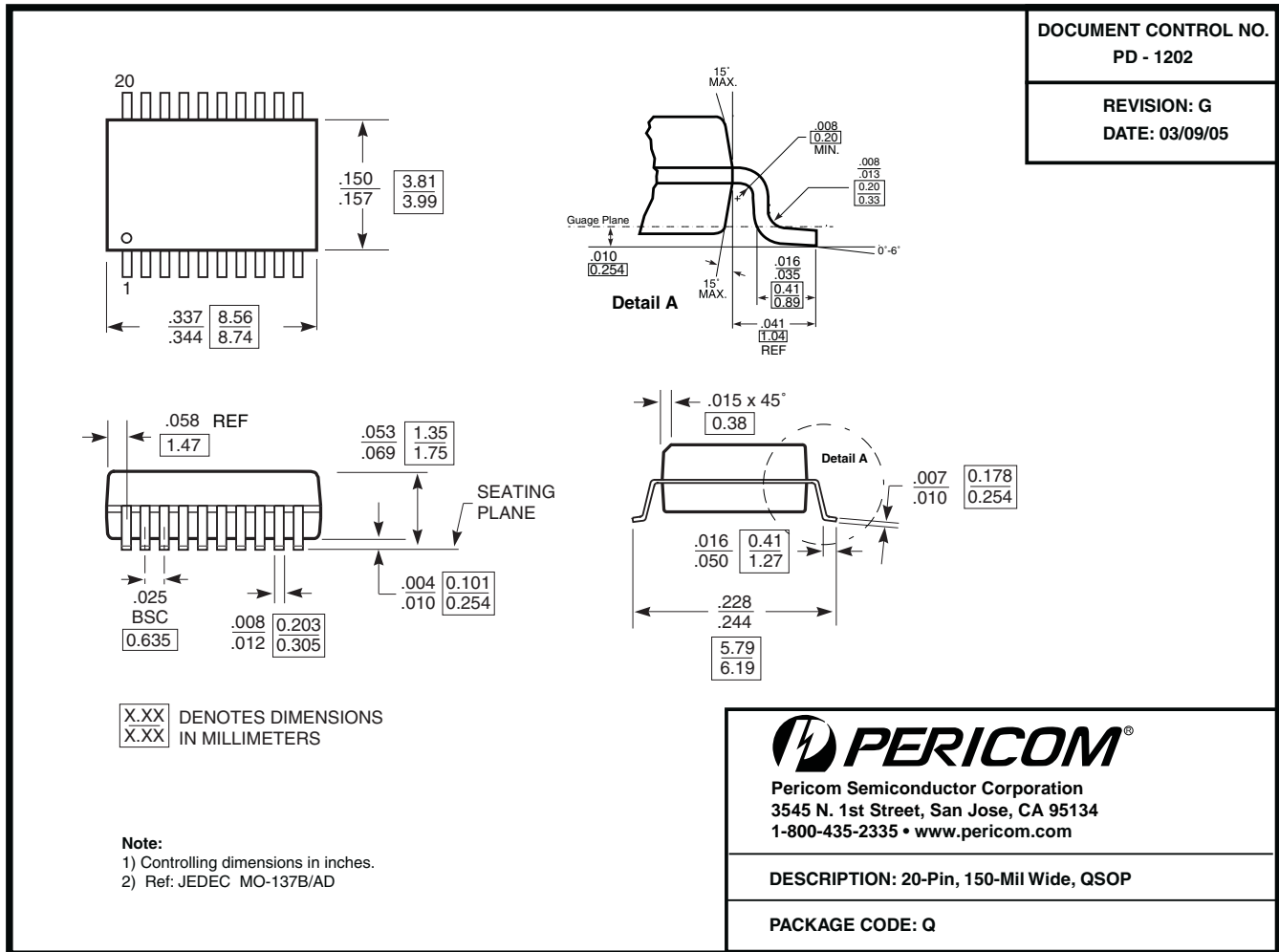
Switching Waveforms

Voltage Waveforms Enable and Disable Times

Packaging Mechanical: 20-Contact QSOP (Q)

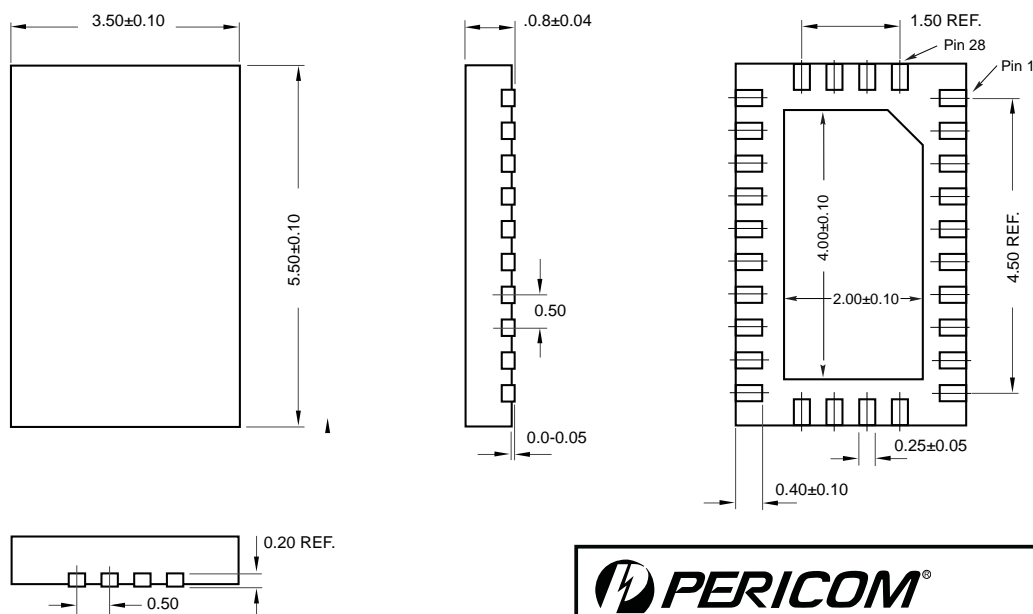
DOCUMENT CONTROL NO.
PD - 2034

REVISION: A
DATE: 03/09/05



Notes:

- 1) All Dimensions are in millimeters.
- 2) Ref JEDEC: MO-220I/WMFD



Pericom Semiconductor Corporation
<http://www.pericom.com>
Tel: (408) 435-0800 • Fax: (408) 435-1100

DESCRIPTION: 28-Contact, Very Thin Quad Flat No-Lead, TQFN

PACKAGE CODE: ZH

Ordering Information

Ordering Code	Package Code	Package Description
PI2DBS212QE	Q	Pb-free & Green, 20-lead QSOP
PI2DBS212ZHE	ZH	Pb-free & Green, 28-contact TQFN

Notes:

- Thermal characteristics can be found on the company web site at www.pericom.com/packaging/
- E = Pb-free & Green
- Adding an X suffix = Tape/Reel