

3V LOW POWER SINGLE TIMERS

- DEDICATED TO 3.3V OR BATTERY SUPPLY (Specified at 3V and 5V)
- VERY LOW POWER CONSUMPTION : **90µA at V_{CC} = 3V**
- WIDE SINGLE SUPPLY RANGE : **+2.7V to +16V**
- HIGH OUTPUT CURRENT CAPABILITY
- SUPPLY CURRENT SPIKES REDUCED DURING OUTPUT TRANSITIONS
- HIGH INPUT IMPEDANCE : **10¹² Ω**
- PIN-TO-PIN AND FUNCTIONALLY COMPATIBLE WITH BIPOLAR NE555 AND CMOS TS555
- OUTPUT COMPATIBLE WITH TTL, CMOS AND LOGIC MOS

DESCRIPTION

The TS3V555 with its low consumption (90µA at V_{CC} = 3V) is a single CMOS timer dedicated to 3.3V or battery supply (specified at 3V and 5V) offering also a high frequency (f_(max) 2MHz at V_{CC} = 3V and 2.7 MHz at V_{CC} = 5V). Thus, either in monostable or astable mode, timing remains very accurate.

Timing capacitors can also be minimized due to high input impedance (10¹² Ω).

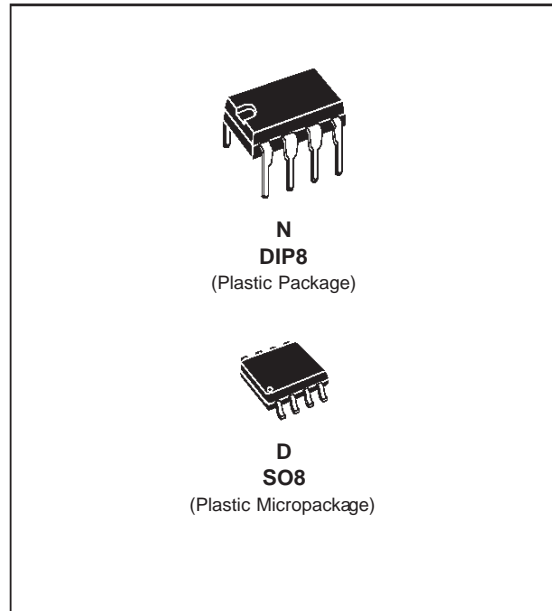

ORDER CODES

Part Number	Temperature Range	Package	
		N	D
TS3V555I	-40, +125°C	●	●

PIN CONNECTIONS (top view)

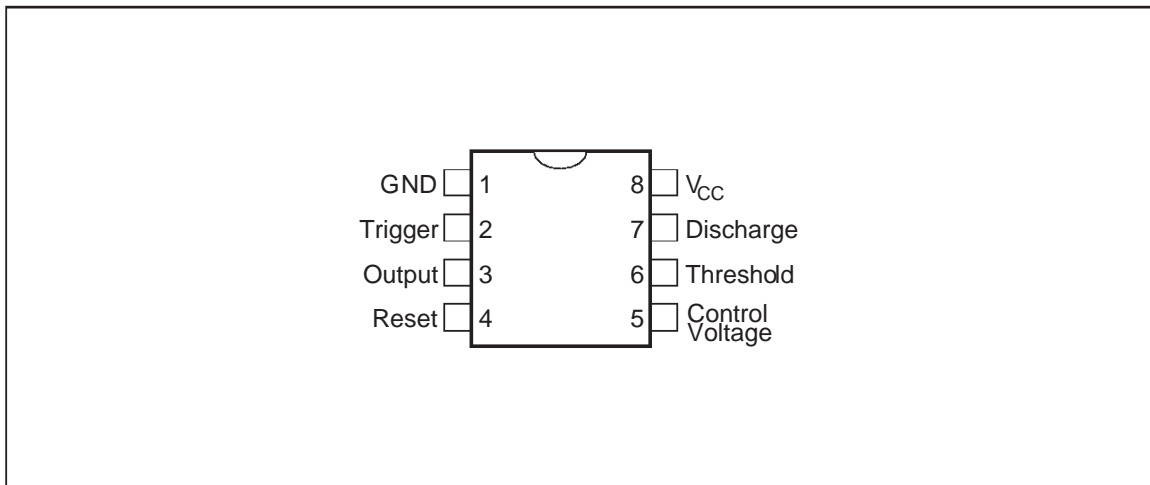

BLOCK DIAGRAM

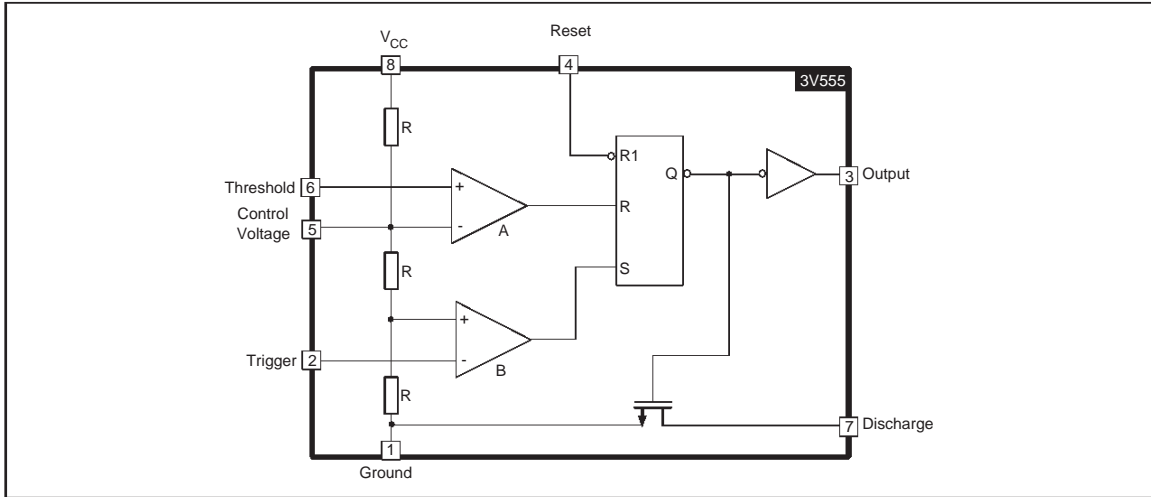

FUNCTION TABLE

RESET	TRIGGER	THRESHOLD	OUTPUT
Low	x	x	Low
High	Low	x	High
High	High	High	Low
High	High	Low	Previous State

- LOW** ↔ Level Voltage ≤ Min voltage specified
- HIGH** ↔ Level Voltage ≥ Max voltage specified
- X** ↔ Irrelevant

ABSOLUTE MAXIMUM RATINGS

Symbol	Parameter	Value	Unit
V _{CC}	Supply Voltage	+18	V
T _J	Junction Temperature	+150	°C

THERMAL CHARACTERISTICS

Symbol	Parameter	Value	Unit
T _{oper}	Operating Temperature Range TS3V555I,AI	-40 to +125	°C
T _{stg}	Storage Temperature Range	-65 to +150	°C

OPERATING CONDITIONS

Symbol	Parameter	Value	Unit
V _{CC}	Supply Voltage	+2.7 to +16	V

ELECTRICAL CHARACTERISTICSV_{CC} = +3V , T_{amb} = +25°C , Reset to V_{CC} (unless otherwise specified)**STATIC**

Symbol	Parameter	TS3V555I			Unit
		Min.	Typ.	Max.	
I _{CC}	Supply Current - (no load, High and Low States) T _{amb} = +25°C T _{min.} ≤ T _{amb} ≤ T _{max.}		90	230 230	μA
V _{CL}	Control Voltage T _{amb} = +25°C T _{min.} ≤ T _{amb} ≤ T _{max.}	1.8 1.7	2	2.2 2.3	V
V _{DIS}	Discharge Saturation Voltage (I _{DIS} = 1mA) T _{amb} = +25°C T _{min.} ≤ T _{amb} ≤ T _{max.}		0.05 -	0.2 0.25	V
V _{OL}	Low Level Output Voltage (I _{SINK} = 1mA) T _{amb} = +25°C T _{min.} ≤ T _{amb} ≤ T _{max.}		0.1	0.3 0.35	V
V _{OH}	High Level Output Voltage (I _{SOURCE} = -0.3mA) T _{amb} = +25°C T _{min.} ≤ T _{amb} ≤ T _{max.}	2.5 2.5	2.9		V
V _{TRIG}	Trigger Voltage T _{amb} = +25°C T _{min.} ≤ T _{amb} ≤ T _{max.}	0.9 0.8	1	1.1 1.2	V
I _{TRIG}	Trigger Current		10		pA
I _{TH}	Threshold Current		10		pA
V _{RESET}	Reset Voltage T _{amb} = +25°C T _{min.} ≤ T _{amb} ≤ T _{max.}	0.4 0.3	1.1	1.5 2.0	V
I _{RESET}	Reset Current		10		pA
I _{DIS}	Discharge Pin Leakage Current		1	100	nA

DYNAMIC

Symbol	Parameter	TS3V555I			Unit
		Min.	Typ.	Max.	
	Timing Accuracy (Monostable) R = 10kΩ , C = 0.1μF - (note 1)		1		%
	Timing Shift with supply voltage variations (Monostable) R = 10kΩ , C = 0.1μF, V _{CC} = +3V +/-0.3V - (note 1)		0.5		%/V
	Timing Shift with temperature - (note 1) T _{min.} ≤ T _{amb} ≤ T _{max.}		75		ppm/°C
f _{max}	Maximum astable frequency - (note 2) R _A = 470Ω , R _B = 200Ω, C = 200pF		2		MHz
	Astable frequency accuracy - (note 2) R _A = R _B = 1kΩ to 100kΩ, C = 0.1μF		5		%
	Timing Shift with supply voltage variations (Astable mode) - (note 2) R _A = R _B = 10kΩ, C = 0.1μF, V _{CC} = +3 to+5V		0.5		%/V
t _r	Output Rise Time (C _{LOAD} = 10pF)		25		ns
t _f	Output Fall Time (C _{LOAD} = 10pF)		20		ns
t _{PD}	Trigger Propagation Delay		100		ns
t _{RPW}	Minimum Reset Pulse Width (V _{TRIG} = +3V)		350		ns

Note : 1. See Figure 2
2. See Figure 4

TS3V555

ELECTRICAL CHARACTERISTICS

$V_{CC} = +5V$, $T_{amb} = +25^{\circ}C$, Reset to V_{CC} (unless otherwise specified)

STATIC

Symbol	Parameter	TS3V555I			Unit
		Min.	Typ.	Max.	
I_{CC}	Supply Current - (no load, High and Low States) $T_{amb} = +25^{\circ}C$ $T_{min.} \leq T_{amb} \leq T_{max.}$		110	250 250	μA
V_{CL}	Control Voltage $T_{amb} = +25^{\circ}C$ $T_{min.} \leq T_{amb} \leq T_{max.}$	2.9 2.8	3.3	3.8 3.9	V
V_{DIS}	Discharge Saturation Voltage ($I_{DIS} = 10mA$) $T_{amb} = +25^{\circ}C$ $T_{min.} \leq T_{amb} \leq T_{max.}$		0.2	0.3 0.35	V
V_{OL}	Low Level Output Voltage ($I_{SINK} = 8mA$) $T_{amb} = +25^{\circ}C$ $T_{min.} \leq T_{amb} \leq T_{max.}$		0.3	0.6 0.8	V
V_{OH}	High Level Output Voltage ($I_{SOURCE} = -2mA$) $T_{amb} = +25^{\circ}C$ $T_{min.} \leq T_{amb} \leq T_{max.}$	4.4 4.4	4.6		V
V_{TRIG}	Trigger Voltage $T_{amb} = +25^{\circ}C$ $T_{min.} \leq T_{amb} \leq T_{max.}$	1.36 1.26	1.67	1.96 2.06	V
I_{TRIG}	Trigger Current		10		μA
I_{TH}	Threshold Current		10		μA
V_{RESET}	Reset Voltage $T_{amb} = +25^{\circ}C$ $T_{min.} \leq T_{amb} \leq T_{max.}$	0.4 0.3	1.1	1.5 2.0	V
I_{RESET}	Reset Current		10		μA
I_{DIS}	Discharge Pin Leakage Current		1	100	nA

DYNAMIC

Symbol	Parameter	TS3V555I			Unit
		Min.	Typ.	Max.	
	Timing Accuracy (Monostable) - (note1) $R = 10k\Omega$, $C = 0.1\mu F$ - (note 1)		2		%
	Timing Shift with supply voltage variations (Monostable) - (note1) $R = 10k\Omega$, $C = 0.1\mu F$, $V_{CC} = +5V \pm 1V$		0.38		%/V
	Timing Shift with temperature - (note1) $T_{min.} \leq T_{amb} \leq T_{max.}$		75		ppm/ $^{\circ}C$
f_{max}	Maximum astable frequency - (note 2) $R_A = 470\Omega$, $R_B = 200\Omega$, $C = 200pF$		2.7		MHz
	Astable frequency accuracy - (note 2) $R_A = R_B = 1k\Omega$ to $100k\Omega$, $C = 0.1\mu F$		3		%
	Timing Shift with supply voltage variations (Astable mode) - (note 2) $R_A = R_B = 10k\Omega$, $C = 0.1\mu F$, $V_{CC} = +5V$ to $+12V$		0.1		%/V
t_r	Output Rise Time ($C_{LOAD} = 10pF$)		25		ns
t_f	Output Fall Time ($C_{LOAD} = 10pF$)		20		ns
t_{PD}	Trigger Propagation Delay		100		ns
t_{RPW}	Minimum Reset Pulse Width ($V_{TRIG} = +5V$)		350		ns

Note : 1. See Figure 2
2. See Figure 4

TYPICAL CHARACTERISTICS

Figure 1 : Supply Current (each timer) versus supply voltage.

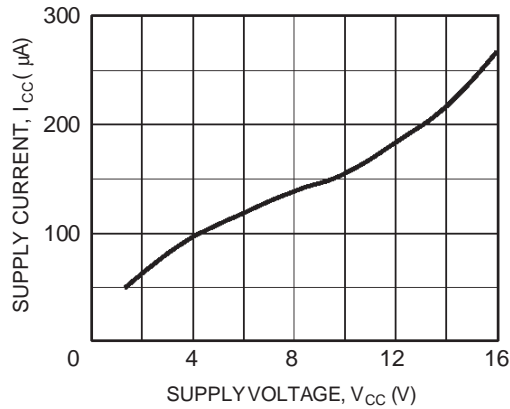

APPLICATION INFORMATION

MONOSTABLE OPERATION

In the monostable mode, the timer functions as a one-shot. Referring to figure 2 the external capacitor is initially held discharged by a transistor inside the timer.

Figure 2

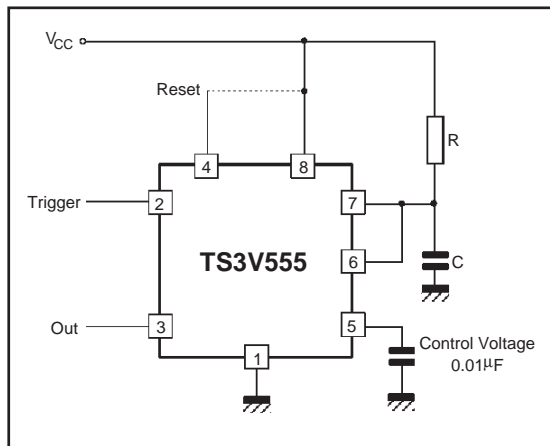

The circuit triggers on a negative-going input signal when the level reaches $1/3 V_{CC}$. Once triggered, the circuit remains in this state until the set time has elapsed, even if it is triggered again during this interval. The duration of the output HIGH state is given by $t = 1.1 R \times C$.

Notice that since the charge rate and the threshold level of the comparator are both directly proportional to supply voltage, the timing interval is independent of supply. Applying a negative pulse simultaneously to the Reset terminal (pin 4) and the Trigger terminal (pin 2) during the timing cycle discharges the external capacitor and causes the cycle to start over. The timing cycle now starts on the positive edge of the reset pulse. During the time the reset pulse is applied, the output is driven to its LOW state.

When a negative trigger pulse is applied to pin 2, the flip-flop is set, releasing the short circuit across the external capacitor and driving the output HIGH. The voltage across the capacitor increases exponentially with the time constant $\tau = R \times C$.

When the voltage across the capacitor equals $2/3 V_{CC}$, the comparator resets the flip-flop which then discharges the capacitor rapidly and drives the output to its LOW state.

Figure 3 shows the actual waveforms generated in this mode of operation.

When Reset is not used, it should be tied high to avoid any possible or false triggering.

Figure 3

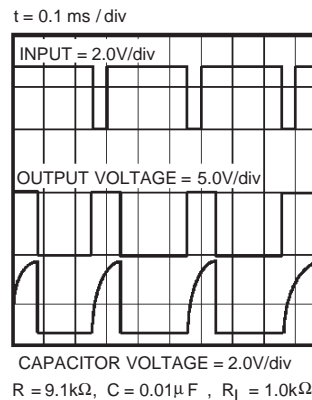

ASTABLE OPERATION

When the circuit is connected as shown in figure 4 (pin 2 and 6 connected) it triggers itself and free runs as a multivibrator. The external capacitor charges through R_A and R_B and discharges through R_B only. Thus the duty cycle may be precisely set by the ratio of these two resistors.

In the astable mode of operation, C charges and discharges between $1/3 V_{CC}$ and $2/3 V_{CC}$. As in the triggered mode, the charge and discharge times and therefore frequency, are independent of the supply voltage.

Figure 5 shows actual waveforms generated in this mode of operation.

The charge time (output HIGH) is given by :

$$t_1 = 0.693 (R_A + R_B) C$$

and the discharge time (output LOW) by :

$$t_2 = 0.693 (R_B) C$$

Thus the total period T is given by :

$$T = t_1 + t_2 = 0.693 (R_A + 2R_B) C$$

The frequency of oscillation is then :

$$f = \frac{1}{T} = \frac{1.44}{(R_A + 2R_B) C}$$

The duty cycle is given by : $D = \frac{R_B}{R_A + 2R_B}$

Figure 4

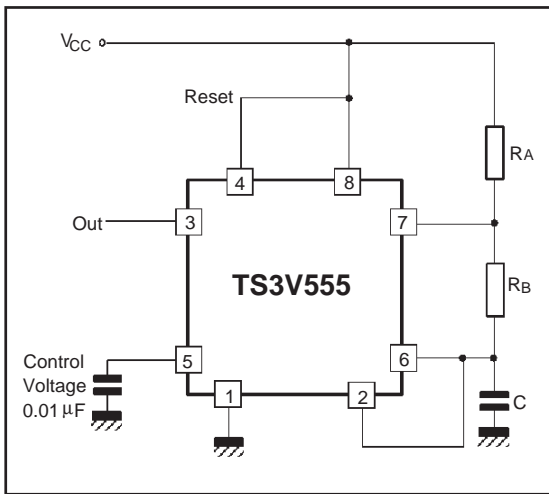
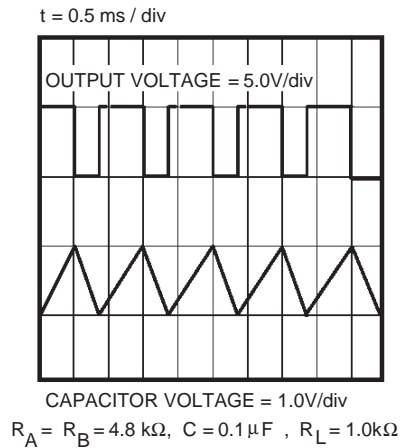
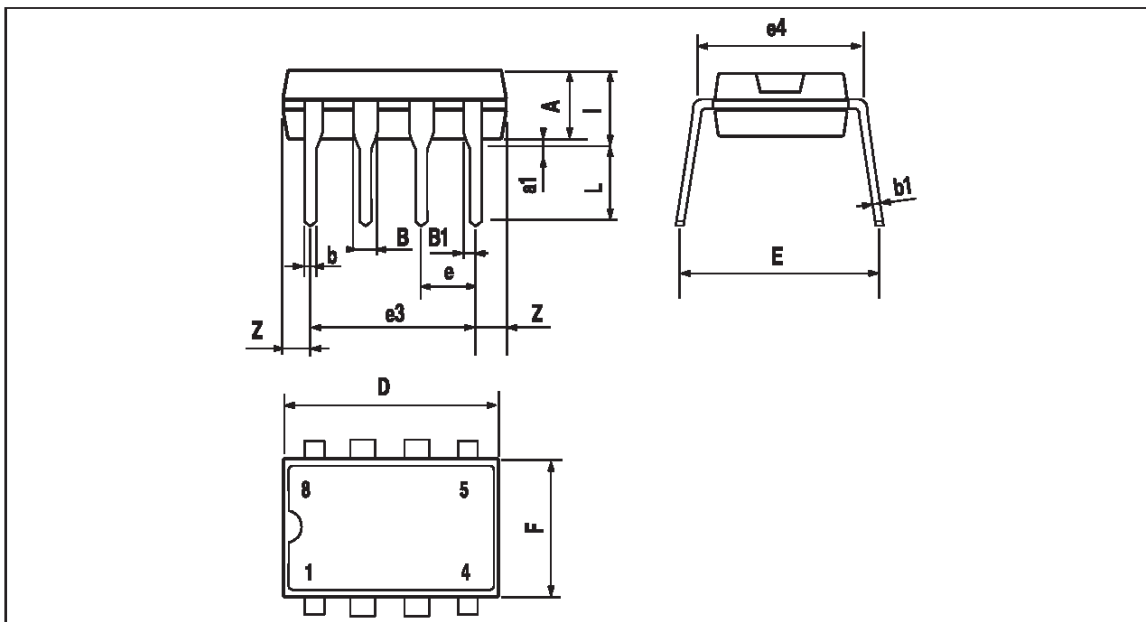

Figure 5



PACKAGE MECHANICAL DATA
8 PINS - PLASTIC DIP



PM-DIP8LEFS

Dimensions	Millimeters			Inches		
	Min.	Typ.	Max.	Min.	Typ.	Max.
A		3.32			0.131	
a1	0.51			0.020		
B	1.15		1.65	0.045		0.065
b	0.356		0.55	0.014		0.022
b1	0.204		0.304	0.008		0.012
D			10.92			0.430
E	7.95		9.75	0.313		0.384
e		2.54			0.100	
e3		7.62			0.300	
e4		7.62			0.300	
F			6.6			0.260
i			5.08			0.200
L	3.18		3.81	0.125		0.150
Z			1.52			0.060

DIP8.TBL

PACKAGE MECHANICAL DATA
8 PINS - PLASTIC MICROPACKAGE (SO)

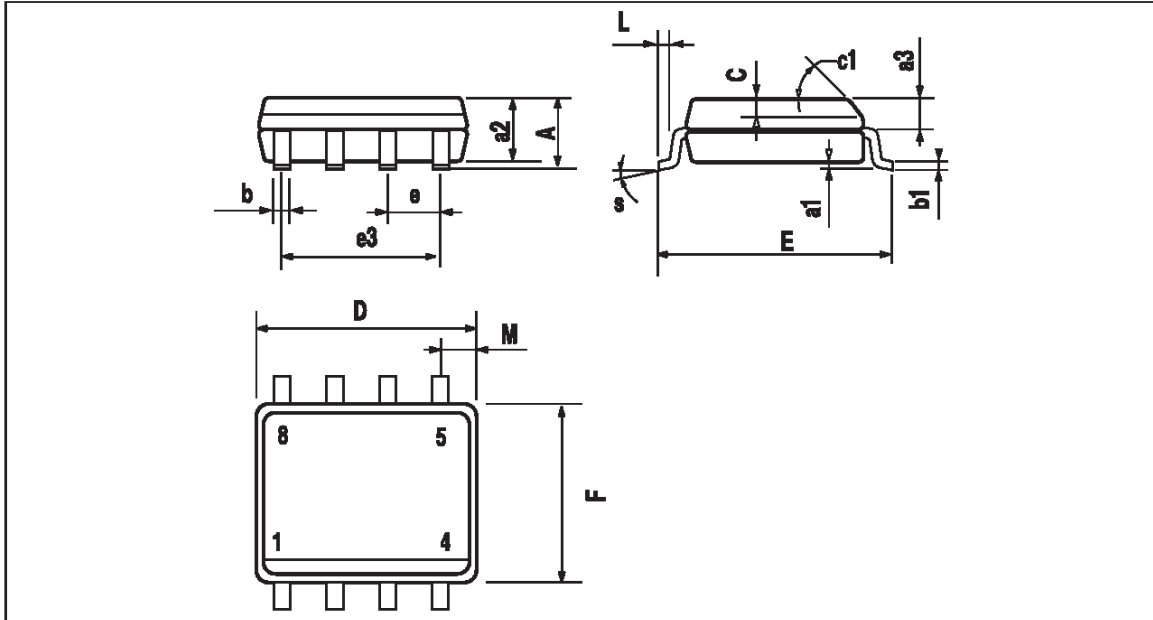

Dimensions	Millimeters			Inches		
	Min.	Typ.	Max.	Min.	Typ.	Max.
A			1.75			0.069
a1	0.1		0.25	0.004		0.010
a2			1.65			0.065
a3	0.65		0.85	0.026		0.033
b	0.35		0.48	0.014		0.019
b1	0.19		0.25	0.007		0.010
C	0.25		0.5	0.010		0.020
c1	45° (typ.)					
D	4.8		5.0	0.189		0.197
E	5.8		6.2	0.228		0.244
e		1.27			0.050	
e3		3.81			0.150	
F	3.8		4.0	0.150		0.157
L	0.4		1.27	0.016		0.050
M			0.6			0.024
S	8° (max.)					

Information furnished is believed to be accurate and reliable. However, SGS-THOMSON Microelectronics assumes no responsibility for the consequences of use of such information nor for any infringement of patents or other rights of third parties which may result from its use. No license is granted by implication or otherwise under any patent or patent rights of SGS-THOMSON Microelectronics. Specifications mentioned in this publication are subject to change without notice. This publication supersedes and replaces all information previously supplied. SGS-THOMSON Microelectronics products are not authorized for use as critical components in life support devices or systems without express written approval of SGS-THOMSON Microelectronics.

© 1997 SGS-THOMSON Microelectronics – Printed in Italy – All Rights Reserved

SGS-THOMSON Microelectronics GROUP OF COMPANIES
Australia - Brazil - Canada - China - France - Germany - Italy - Japan - Korea - Malaysia - Malta - Morocco
The Netherlands - Singapore - Spain - Sweden - Switzerland - Taiwan - Thailand - United Kingdom - U.S.A.