

Features

- 5-ohm Switch Connection Between Two Ports
- Near-Zero Propagation Delay
- Fast Switching Speed: 4.5ns (max.)
- Ultra -Low Quiescent Power (0.2mA typ.)
 - Ideal for notebook applications.
- Industrial Operating Temperature: -40°C to 85°C
- Package (Pb-free & Green available):
 - 56-pin 240-mil wide plastic TSSOP (A)
 - 56-pin 300-mil wide plastic SSOP (V)

Description

Pericom Semiconductor's PI3B16233 is a 16-bit to 32-bit mux/demux switch. This device can be used for memory bank interleaving. The PI3B16233 can be used as two 8-bit to 16-bit multiplexers or as one 16-bit to 32-bit multiplexer.

Two select inputs (SEL1 and SEL2) control the data flow. When the TEST inputs are asserted HIGH, the A port is connected to both the B1 and the B2 ports.

Block Diagram

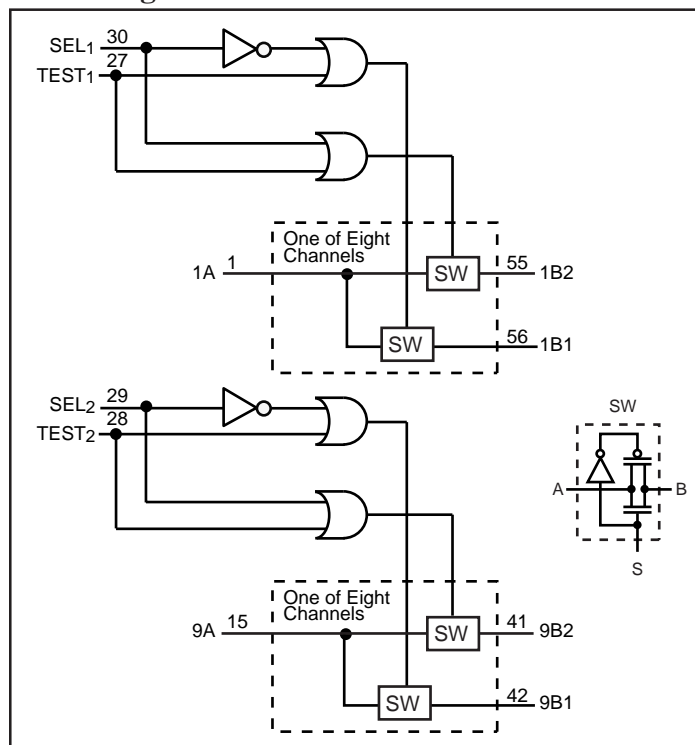

Pin Configuration

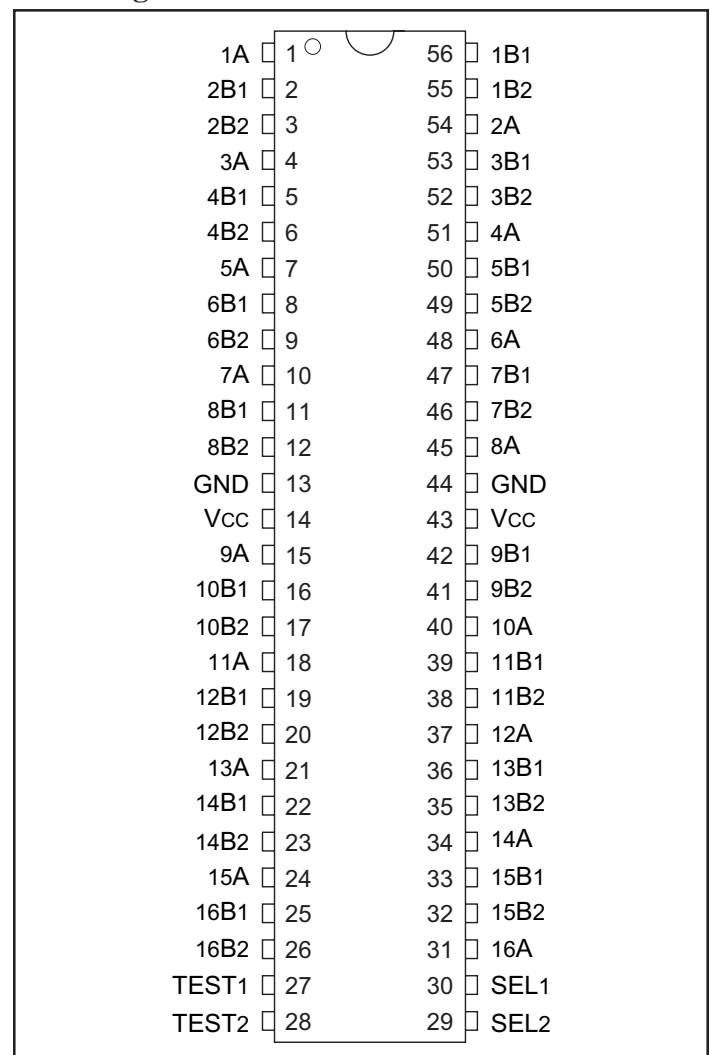

Function Table

Inputs		Function
SEL	TEST	
L	L	A = B1
H	L	A = B2
X	H	A = B1 and A = B2

Maximum Ratings

(Above which the useful life may be impaired. For user guidelines, not tested.)

Storage Temperature	-65°C to +150°C
Ambient Temperature with Power Applied	-40°C to +85°C
Supply Voltage Range	-0.5V to +4.6V
DC Input Voltage	-0.5V to +4.6V
DC Output Current	120mA
Power Dissipation	0.5W

Note:

Stresses greater than those listed under MAXIMUM RATINGS may cause permanent damage to the device. This is a stress rating only and functional operation of the device at these or any other conditions above those indicated in the operational sections of this specification is not implied. Exposure to absolute maximum rating conditions for extended periods may affect reliability.

DC Electrical Characteristics (Over the Operating Range, $T_A = -40^\circ\text{C}$ to $+85^\circ\text{C}$, $V_{CC} = 3.0\text{V}$ to 3.6V)

Parameters	Description	Test Conditions ⁽¹⁾	Min.	Typ. ⁽²⁾	Max.	Units
V_{IH}	Input HIGH Voltage	Guaranteed Logic High Level	2.0			V
V_{IL}	Input LOW Voltage	Guaranteed Logic Low Level	-0.5		0.8	
I_{IH}	Input HIGH Current	$V_{CC} = \text{Max.}, V_{IN} = V_{CC}$			± 1	μA
I_{IL}	Input LOW Current	$V_{CC} = \text{Max.}, V_{IN} = \text{GND}$			± 1	
I_{OZH}	High Impedance Output Current	$0 \leq A, B \leq V_{CC}$			± 1	
V_{IK}	Clamp Diode Voltage	$V_{CC} = \text{Min.}, I_{IN} = -18\text{mA}$		-0.7	-1.2	V
R_{ON}	Switch ON Resistance ⁽³⁾	$V_{CC} = \text{Min.}, V_{IN} = 0.0\text{V}, I_{ON} = 48\text{mA}$ or 64mA $V_{CC} = \text{Min.}, V_{IN} = 2.4\text{V}, I_{ON} = 15\text{mA}$		5 10	8 15	Ω

Notes:

- For Max. or Min. conditions, use appropriate value specified under Electrical Characteristics for the applicable device type.
- Typical values are at $V_{CC} = 3.3\text{V}$, $T_A = 25^\circ\text{C}$ ambient and maximum loading.
- Measured by the voltage drop between A and B pin at indicated current through the switch. ON resistance is determined by the lower of the voltages on the two (A,B) pins.

Capacitance ($T_A = 25^\circ\text{C}$, $f = 1\text{MHz}$)

Parameters ⁽¹⁾	Description	Test Conditions	Typ.	Units
C_{IN}	Input Capacitance	$V_{IN} = 0\text{V}$	3.0	pF
C_{ON}	A/B Capacitance, Switch On		25.0	

Notes:

- This parameter is determined by device characterization but is not production tested.

Power Supply Characteristics

Parameters	Description	Test Conditions ⁽¹⁾		Min.	Typ ⁽²⁾	Max.	Units
I _{CC}	Quiescent Power Supply Current	V _{CC} = Max.	V _{IN} = GND or V _{CC}			10	μA
ΔI _{CC}	Supply Current per Input @ TTL High	V _{CC} = Max.	V _{IN} = 3.0V ⁽³⁾			750	
I _{CCD}	Supply Current per Input per MHz ⁽⁴⁾	V _{CC} = Max. A & B Pin Open Control Input Toggling 50% Duty Cycle				0.25	mA/ MHz

Notes:

1. For Max. or Min. conditions, use appropriate value specified under Electrical Characteristics for the applicable device.
2. Typical values are at V_{CC} = 3.3V, +25°C ambient.
3. Per TTL driven input (control inputs only); A and B pins do not contribute to I_{CC}.
4. This current applies to the control inputs only and represent the current required to switch internal capacitance at the specified frequency. The A and B inputs generate no significant AC or DC currents as they transition. This parameter is not tested, but is guaranteed by design.

Switching Characteristics over Operating Range

Parameters	Description	Conditions	Com.		Units
			Max.	Min.	
t _{PLH} t _{PHL}	Propagation Delay ^(1,2) Ax to Bx, Bx to Ax	C _L = 50pF, R _L = 500-ohm		0.25	ns
t _{PZH} t _{PZL}	Bus Enable Time SEL _X to Ax or Bx	C _L = 50pF, R _L = 500-ohm, R = 500-ohm	1	4.5	
t _{PHZ} t _{PLZ}	Bus Disable Time SEL _X to Ax or Bx	C _L = 50pF, R _L = 500-ohm	1	5.0	

Notes:

1. This parameter is guaranteed but not tested on Propagation Delays.
2. The bus switch contributes no propagational delay other than the RC delay of the ON resistance of the switch and the load capacitance. The time constant for the switch alone is of the order of 0.25ns for 50pF load. Since this time constant is much smaller than the rise/fall times of typical driving signals, it adds very little propagational delay to the system. Propagational delay of the bus switch when used in a system is determined by the driving circuit on the driving side of the switch and its interaction with the load on the driven side.

Packaging Mechanical: 56-Pin TSSOP (A)

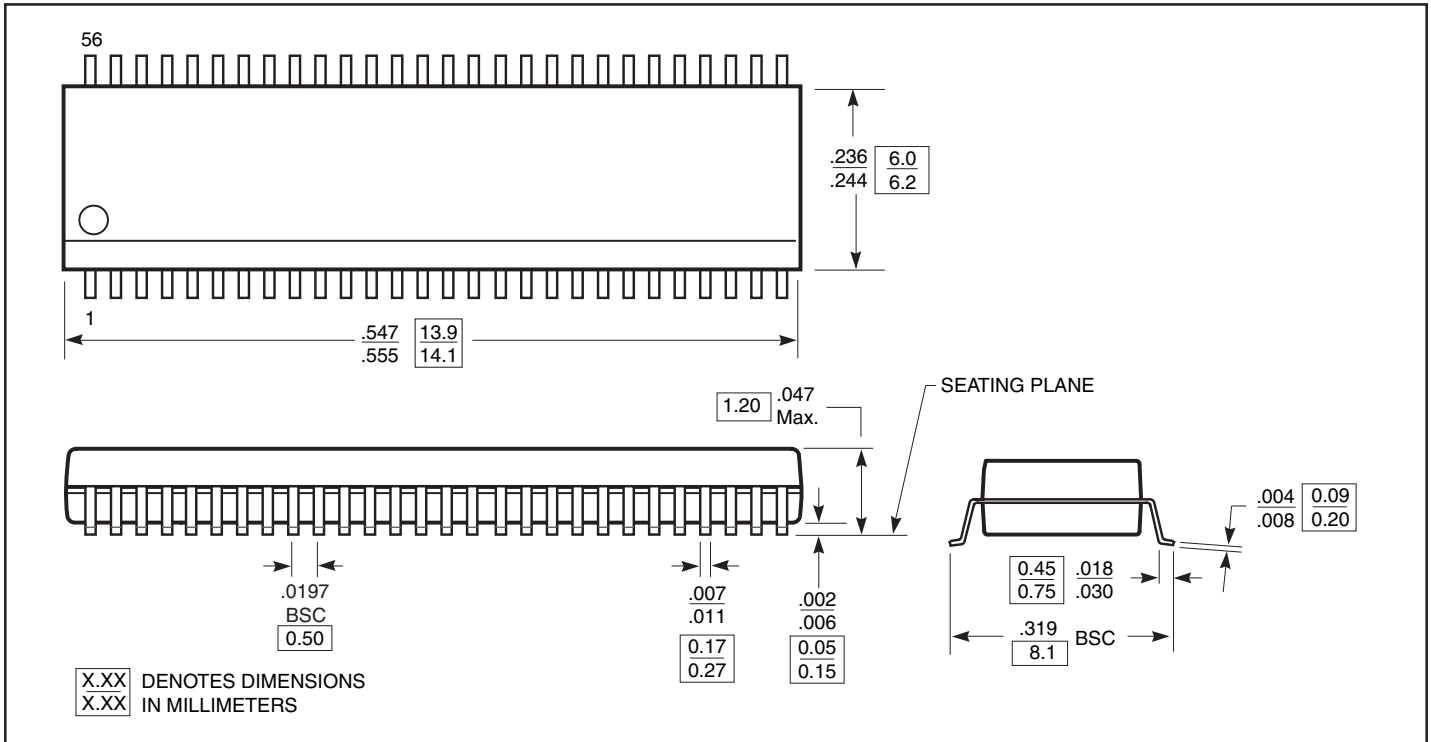

Packaging Mechanical: 56-Pin SSOP (V)

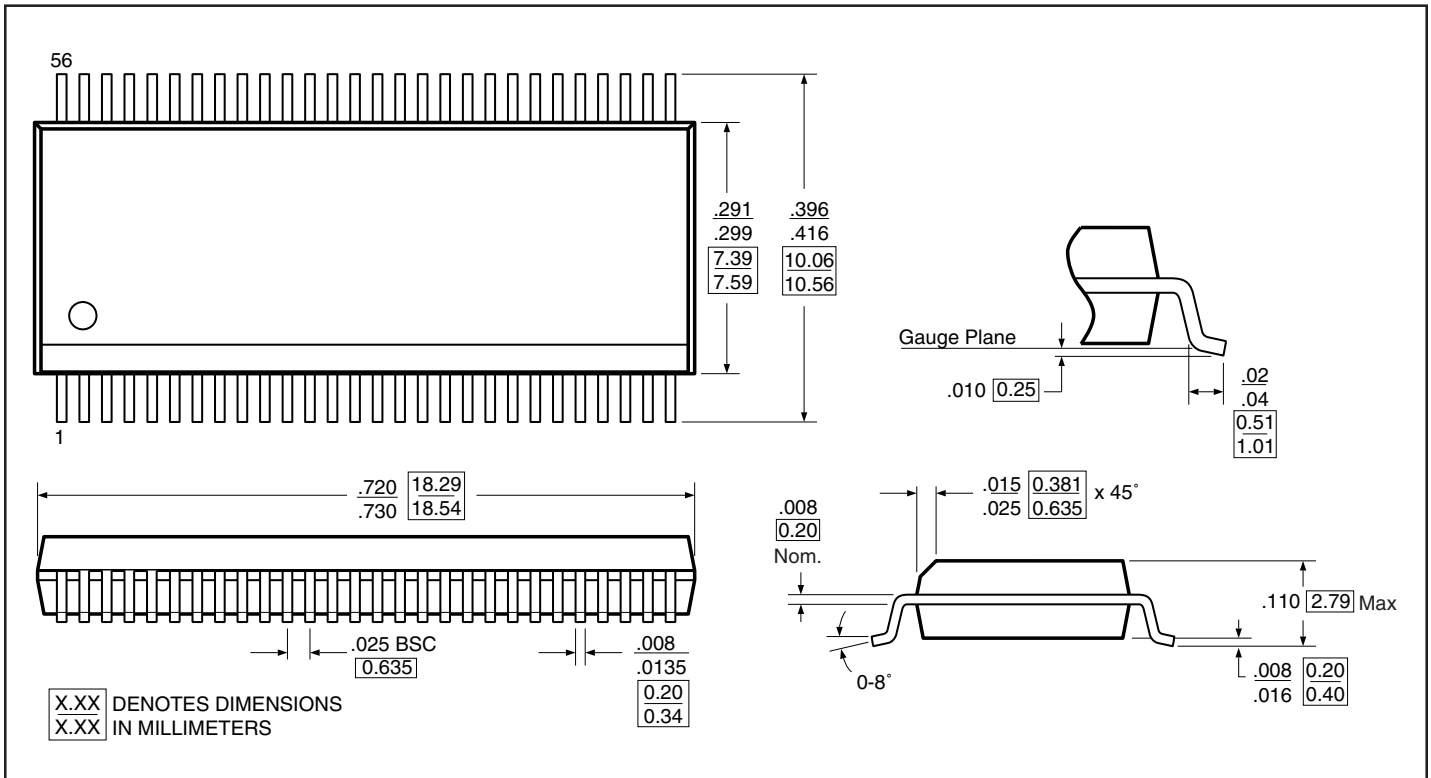

Applications Information

Logic Inputs

The logic control inputs can be driven up to +3.6V regardless of the supply voltage. For example, given a + 3.3V supply, IN may be driven low to 0V and high to 3.6V. Driving IN Rail-to-Rail® minimizes power consumption.

Power-Supply Sequencing and Hot-Plug Information

Proper power-supply sequencing is recommended for all CMOS devices. Always apply V_{CC} and GND before applying signals to input/output or control pins.

Rail-to-Rail is a registered trademark of Nippon Motorola, Ltd.

Ordering Information

Ordering Code	Package Code	Package Type
PI3B16233A	A	56-pin 240-mil wide TSSOP
PI3B16233AE	A	Pb-free & Green, 56-pin 240-mil wide TSSOP
PI3B16233V	V	56-pin 300-mil wide SSOP
PI3B16233VE	V	Pb-free & Green, 56-pin 300-mil wide SSOP

Notes:

- Thermal characteristics can be found on the company web site at www.pericom.com/packaging/
- E = Pb-free & Green
- Adding an X suffix = Tape/Reel